

For Absolute Solutions

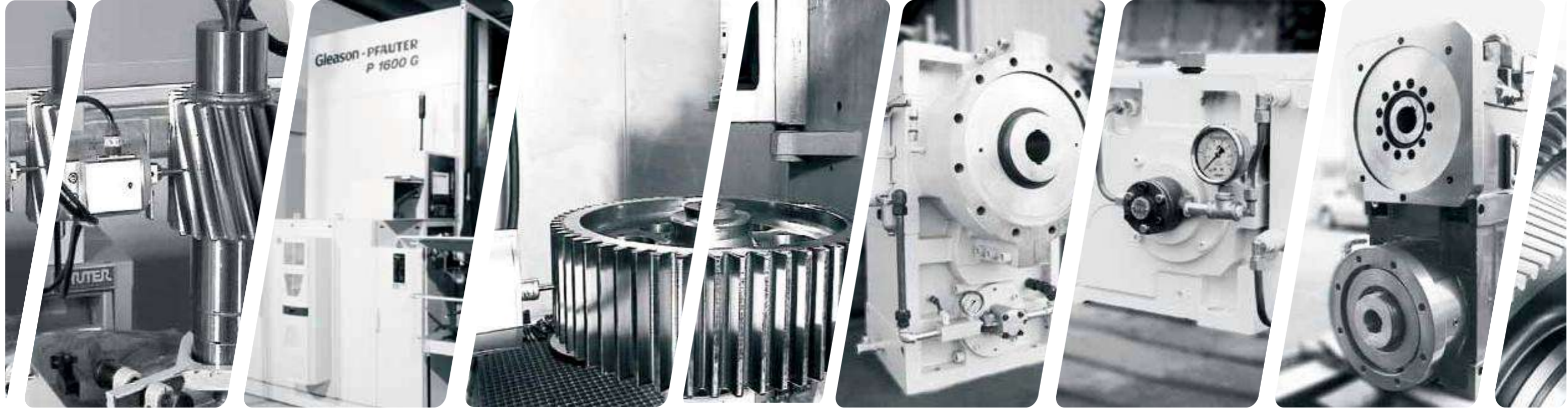

Gearbox for Single-Screw Extruder

POLAT GROUP REDÜKTÖR SAN. VE TİC.A.Ş.
Ata Mah. Astim OSB 1. Cd. No: 4 Efeler - AYDIN / TÜRKİYE
TEL : 0256 231 19 12 (pbx) FAX : 0256 231 19 17



info@pgr.com.tr
www.pgr.com.tr

Gearbox Selection Process

STEP		Reference
Step1	<p>SELECT NOMINAL RATIO In</p> <p>$I_{Req} = n1/n2$</p> <p>Example : $n1 = 1750 \text{ rpm}$; $n2 = 120 \text{ rpm}$</p> <p>$I_{Req} = 1750/120 = 14.58$</p> <p>Choose In close I Req' see Tables In = 16</p>	<p>In = Nominal Ratio</p> <p>I Req = Ratio (required)</p> <p>n1 = Input speed</p> <p>n2 = Driven machine speed</p>
Step2	<p>CALCULATE SINGLE SHAFT OUTPUT TORQUE T Req</p> $T_{Req} = \frac{P \times 9.55 \times SF}{n2} \text{ kNm}$ <p>Example : $P = 75 \text{ kw}$; $SF = 1.6$; $n2 = 120 \text{ rpm}$</p> <p>$T_{Req} = 75 \times 9.55 \times 1.6 / 120 = 9.55 \text{ kNm}$</p> <p>For general conditions, our suggestion of SF is 1.6, If you have other different requirement, please contact with our Research & Development Dept.</p>	<p>P = Power of Working Machine</p> <p>SF = Service Factor for Driven Machine</p> <p>n2 = Driven machine speed</p> <p>T Req = Torsion of single shaft (required)</p>
Step3	<p>SELECT GEAR UNIT TYPE AND SIZE</p> <p>$Tn > T_{Req}$</p> <p>Example : $T_{Req} = 9.55 \text{ kNm}$</p> <p>Gear unit type PEX 200-3S with Nominal Torque T Req=11.52kNm</p> <p>$Tn \geq T_{Req}$ PEX 200-3S Gear Unit is okay</p>	<p>Tn = Nominal torsion</p> <p>T Req = Torsion of single shaft (required)</p>
Step4	<p>DETERMINE REQUIRED THERMAL CAPACITY</p> <p>$P > PG$ ' Additional cooling is required.</p> <p>$PG > P$ ' Cooling system is sufficient.</p> <p>Example : $P = 75KW$</p> <p>When I adopt PEX 200-3S gear case, please according to TABLE1 PG</p> <p>Knowing $PG = 37 \text{ kw}$ ' $P > PG$</p> <p>Additional cooling is required</p>	<p>P = Power of Working Machine</p> <p>PG = Thermal Capacity</p>
Step5	<p>CALCULATE THRUST LOAD</p> $Fa = \pi \times \frac{ds^2 \times PS}{4 \times 10000} \text{ kN}$ <p>Example : $ds = 100 \text{ mm}$; $PS=200 \text{ Bar}$</p> $Fa = \pi \times \frac{100^2 \times 200}{4 \times 10000} = 157 \text{ kN}$	<p>ds = Screw Diameter</p> <p>Ps = Pressure on screw</p> <p>Fa = Thrust Load</p> <p>1 bar = 14.5 Psi</p>
Step6	<p>CALCULATE NOMINAL THRUST BEARING LIFE TIME</p> $Lh10 = \frac{10^6}{60 \times n2} \times \left(\frac{Cdyn}{Fa} \right)^{\left(\frac{10}{3} \right)} \text{ [hr]}$ <p>Example : $n2 = 120 \text{ rpm}$; $Cdyn = 1400 \text{ kN}$; $Fa = 157 \text{ kN}$</p> $Lh10 = \frac{10^6}{60 \times 120} \times \left(\frac{1400}{157} \right)^{\left(\frac{10}{3} \right)} = 204218 \text{ [hr]}$ <p>NOMINAL THRUST BEARING LIFE TIME $\geq 204218 \text{ [hr]}$</p>	<p>Lh10 = LIFE TIME</p> <p>n2 = Driven machine speed</p> <p>Cdyn = Dyn.Capacity Thrust Bearing</p> <p>Fa = Thrust Load</p>

Single Screw Features

SINGLE SCREW EXTRUDER - TWO STAGE

Specification

- Screw dia: 0 ~ 250mm
- Rated torque: 0 ~ 100,000Nm

Low noise

- dB ≤ 70

Compact Structure

- Smooth gear-reduction mechanism: Featuring gears that mesh precisely, quiet spiral-gear drive for minimal backlash and high torque output.

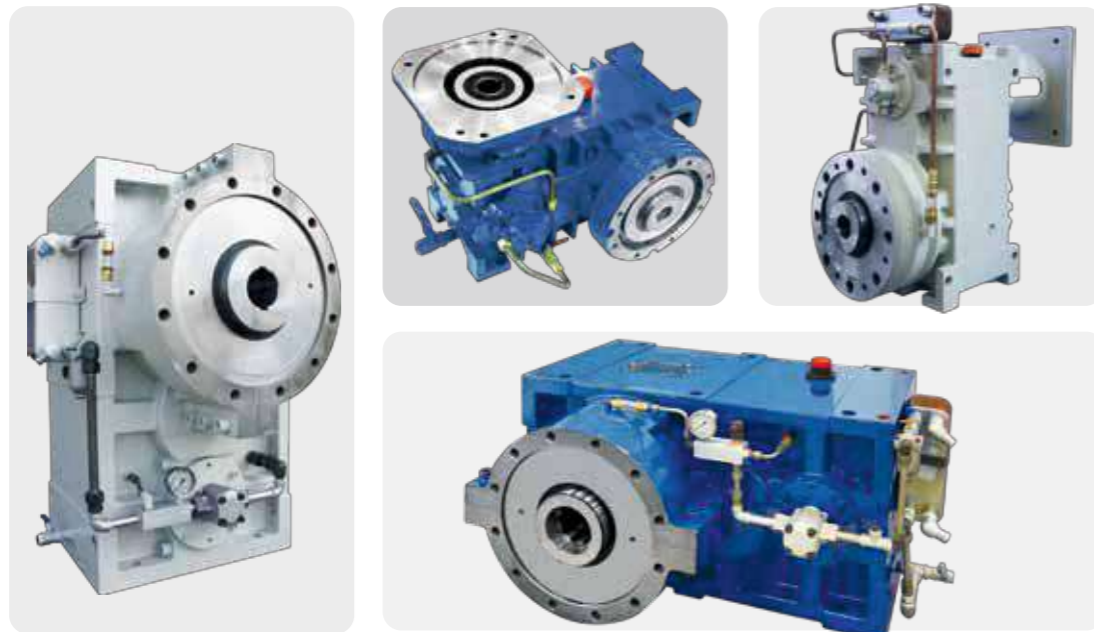

Torque Data Sheet

(Two stage reduction) Gearbox For Single-Screw Extruder (Table)							
Type	Nominal Ratio (In)						
	8	10	12	16	20	25	30
Nominal Torsion of driven machine [kN.M]							
PEX-112-3S	2.08	2.08	2.08	1.6	1.6	1.6	1.12
PEX-125-3S	2.64	2.64	2.64	2	2	2	1.44
PEX-140-3S	4.4	4.4	4.4	3.36	3.36	3.36	2.24
PEX-160-3S	6.24	6.24	6.24	4.8	4.8	4.8	3.68
PEX-180-3S	9.76	9.76	9.76	7.44	7.44	7.44	5.2
PEX-200-3S	15.2	15.2	15.2	11.5	11.52	11.52	8
PEX-225-3S	23.2	23.2	23.2	17.6	17.6	17.6	12.32
PEX-250-3S	30.4	30.4	30.4	23.2	23.2	23.2	16
PEX-280-3S	37.6	37.6	37.6	28	28	28	20
PEX-320-3S	60.8	60.8	60.8	45.6	45.6	45.6	32
PEX-360-3S	85.6	85.6	85.6	64.8	64.8	64.8	45.6
PEX-400-3S	126.4	126.4	126.4	96	96	96	67.2

(Two stage reduction) Gearbox For Single-Screw Extruder (Table)						
Type	(PG) Thermal Capacity [KW]	Model of Trust Bearing	(Cdyn) [kN]	Advise Screw Diameter [mm]	Weight [KG]	Oil Volume [LITER]
PEX-112-3S	7.5	29413	410	Ø 25- Ø 35	85	3.5
PEX-125-3S	11	29415	525	Ø 35- Ø 45	118	5
PEX-140-3S	19	29417	640	Ø 45- Ø 55	165	7
PEX-160-3S	22	29420	870	Ø 55- Ø 75	210	10
PEX-180-3S	30	29424	1210	Ø 65- Ø 80	325	14
PEX-200-3S	37	29426	1400	Ø 80- Ø 90	490	20
PEX-225-3S	56	29430	1663	Ø 90- Ø 100	616	27
PEX-250-3S	75	29432	1820	Ø 100- Ø 120	820	36
PEX-280-3S	94	29436	1950	Ø 110- Ø 130	1205	49
PEX-320-3S	112	29440	2350	Ø 120- Ø 150	1608	64
PEX-360-3S	150	29444	2410	Ø 150- Ø 200	2145	80
PEX-400-3S	225	29452	2940	Ø 200- Ø 250	2720	108

Overall Dimensions

Specifications

Unit : mm

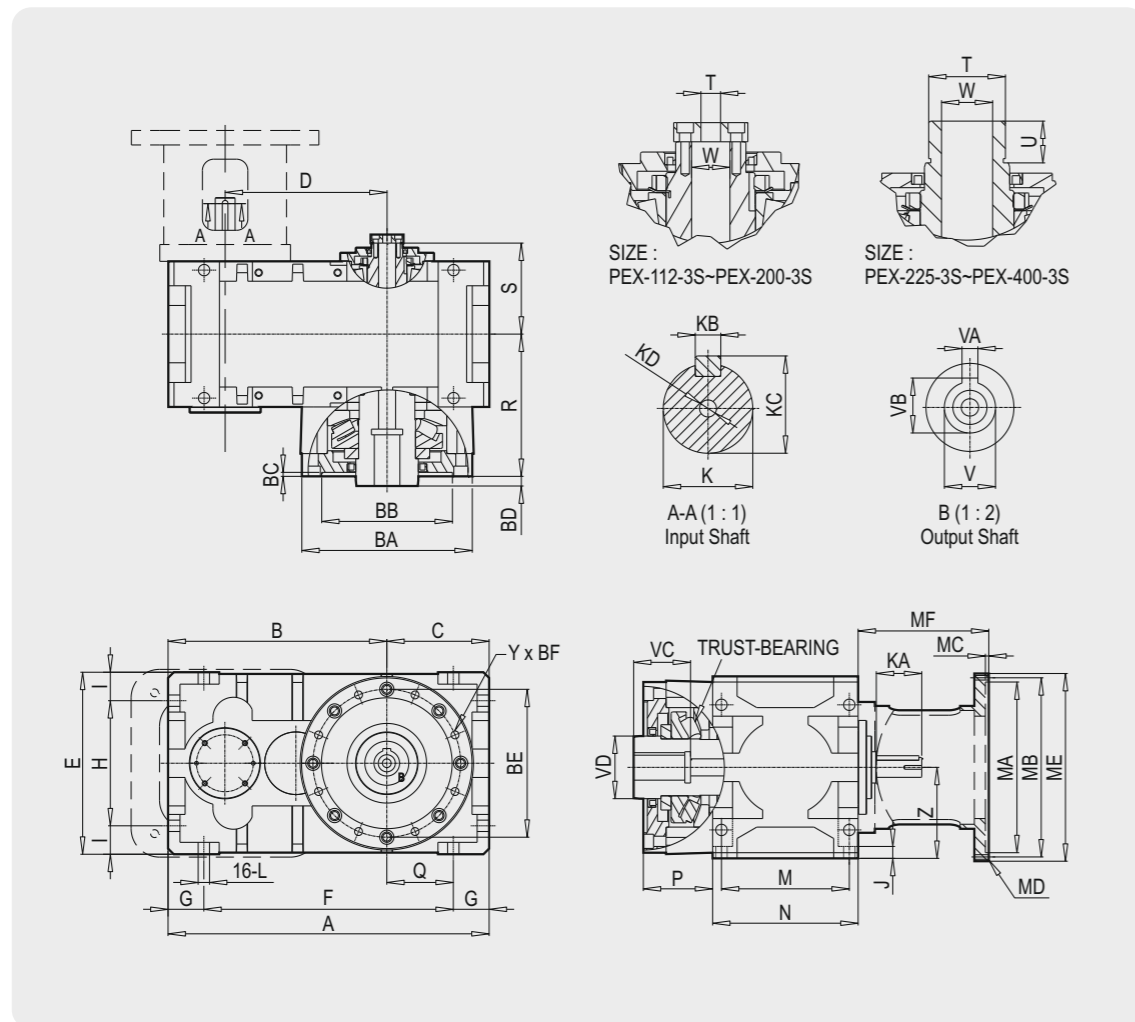

Type	Size	A	B	C	D	E	F	G	H	I	J
PEX-112-3S		407	282	125	202	224	307	50	144	40	16
PEX-125-3S		445	305	140	225	250	345	50	160	45	16
PEX-140-3S		502	342	160	252	280	390	56	184	48	18
PEX-160-3S		565	385	180	285	320	439	63	220	50	21
PEX-180-3S		632	432	200	320	360	492	70	240	60	25
PEX-200-3S		710	485	225	360	400	550	80	260	70	30
PEX-225-3S		795	545	250	405	450	612	90	290	80	30
PEX-250-3S		890	610	280	450	500	690	100	320	90	30
PEX-280-3S		1000	685	315	505	560	776	112	360	100	48
PEX-320-3S		1125	770	355	570	640	875	125	416	112	54
PEX-360-3S		1265	865	400	640	720	985	140	470	125	55
PEX-400-3S		1420	970	450	720	800	1100	160	520	140	60

Type	Size	L(Ø)	M	N	P	Q	R	S	T	U	W(Ø)	Z
PEX-112-3S		Ø 14	172	196	94	75	180	125	M14	0	Ø 18	112
PEX-125-3S		Ø 16	180	204	115	90	205	135	M18	0	Ø 22	125
PEX-140-3S		Ø 18	200	235	115	104	212.5	145	M18	0	Ø 25	140
PEX-160-3S		Ø 20	225	256	137.5	117	250	160	M18	0	Ø 30	160
PEX-180-3S		Ø 22	250	286	150	130	275	190	M20	0	Ø 35	180
PEX-200-3S		Ø 24	280	320	180	145	320	245	M85	50	Ø 45	200
PEX-225-3S		Ø 26	315	360	197.5	160	355	270	M85	50	Ø 55	225
PEX-250-3S		Ø 30	355	407	227.5	180	405	300	M85	50	Ø 55	250
PEX-280-3S		Ø 33	400	460	245	203	445	320	M90	50	Ø 60	280
PEX-320-3S		Ø 36	450	520	265	230	490	350	M90	50	Ø 60	320
PEX-360-3S		Ø 39	500	580	310	260	560	390	M120	50	Ø 80	360
PEX-400-3S		Ø 42	560	650	360	290	640	425	M120	50	Ø 80	400

Size Type	Barrels (customize)							Screw (customize)					Input shaft					Motor Flange					
	BA(Ø)	BB(Ø)	BC	BD	BE(Ø)	Y	BF	V(Ø)	VA	VB	VC	VD(Ø)	K(Ø)	KA(Ø)	KB	KC	KD	MA	MB(Ø)	MC	MD	MF	Flange
PEX-112-3S	200	150	6	0	170	8	M12	22	6	25.3	60	70	24	60	8	27	M8	230	265	5	4-M12	186	10HP-4P
PEX-125-3S	230	180	6	8	205	8	M12	28	10	31.3	80	80	28	65	8	31	M8	230	265	5	4-M12	186	7.5HP-6P
PEX-140-3S	260	200	6	8	230	8	M12	35	12	38.3	80	90	32	80	10	35	M8	250	300	6	4-M16	230	15/20HP-4P
PEX-160-3S	300	230	6	17	260	8	M12	45	14	48.8	100	110	35	90	10	38	M10	250	300	6	4-M16	230	10/15HP-6P
PEX-180-3S	350	260	6	17	300	8	M20	50	14	53.8	110	130	40	95	12	43	M10	300	350	6	4-M16	250	30/40HP-4P
PEX-200-3S	380	290	6	18	330	8	M20	60	160	64.3	120	140	45	110	14	48.5	M10	300	350	6	4-M16	250	20/30HP-6P
PEX-225-3S	400	310	6	18	350	12	M20	70	20	74.9	140	160	50	120	14	53.5	M12	350	400	6	8-M16	285	50/60HP-4P
PEX-250-3S	450	365	8	20	400	12	M24	80	22	85.3	140	170	55	130	16	59	M12	350	400	6	8-M16	285	40/50HP-6P
PEX-280-3S	500	400	8	20	450	12	M24	90	25	95.4	140	180	60	150	18	64	M16	450	500	6	8-M16	305	75/100HP-4P
PEX-320-3S	600	450	8	20	500	12	M24	100	28	106	140	190	70	170	20	75	M16	450	500	6	8-M16	305	60/75HP-6P
PEX-360-3S	680	520	10	24	600	12	M30	110	28	116	180	200	80	190	22	85	M20	-	-	-	-	-	-
PEX-400-3S	750	600	10	24	680	12	M33	130	32	137	180	220	90	210	25	95	M20	-	-	-	-	-	-

Single Screw Features

SINGLE SCREW EXTRUDER - THREE STAGE

Advance 4 Shaft Design

- 4 shafts design requires less motor output, power consumption is lower than those of pulley

Compact Structure

- Allows more work space on your machine table
- Barrel and motor could be on the same direction
- Motor shaft can connect to our gearbox directly

Cost Down

- No Coupling and adapter needed
- No drive pulley and belt needed
- Electricity saving, also save your electrical bill

Easy Maintenance. Easy Install

- Easy motor mounting. Motor axle can be connected to gearboxes with some bolts
- Easy maintenance. No special tools required to disassemble. No irritating maintaining processes, just change lubricating oil regularly



Torque Data Sheet

(Three stage reduction) Gearbox For Single-Screw Extruder (Table)

Type	Nominal Ratio (In)						
	10	16	20	25	30	40	50
	(Tn) Nominal Torsion of driven machine [kN.M]						
PEX-125-4S	4.27	4.07	3.88	3.70	3.52	3.36	3.20
PEX-140-4S	6.40	6.08	5.92	5.76	5.60	4.96	4.64
PEX-160-4S	8.64	8.48	8.16	8.00	7.68	7.52	7.04
PEX-180-4S	13.28	12.96	12.64	12.48	12.32	11.84	10.72
PEX-200-4S	20.80	19.68	19.20	18.72	18.40	17.28	16.00
PEX-225-4S	30.72	29.60	28.32	27.20	25.92	23.52	22.40
PEX-250-4S	40.10	38.40	35.68	34.72	33.60	29.60	26.88
PEX-280-4S	56.00	52.00	50.40	48.32	47.20	43.20	40.20
PEX-320-4S	92.00	85.60	82.40	79.20	76.05	72.12	65.60
PEX-360-4S	110.40	103.20	100.00	92.00	94.40	85.60	81.60
PEX-400-4S	160.80	146.40	144.00	140.00	136.10	122.40	111.20

(Three stage reduction) Gearbox For Single-Screw Extruder (Table)

Type	(PG) Thermal Capacity [KW]	Model of Trust Bearing	(Cdyn) [kN]	Advise Screw Diameter [mm]	Weight [KG]	Oil Volume [LITER]
PEX-125-4S	19	29416	580	Ø 35- Ø 45	122	5.4
PEX-140-4S	22	29418	710	Ø 45- Ø 55	161	7
PEX-160-4S	30	29422	1060	Ø 55- Ø 75	253	9.5
PEX-180-4S	37	29424	1210	Ø 65- Ø 80	334	15
PEX-200-4S	56	29428	1410	Ø 80- Ø 90	485	30
PEX-225-4S	75	29430	1663	Ø 90- Ø 100	655	26
PEX-250-4S	94	29432	1820	Ø 100- Ø 120	910	48
PEX-280-4S	1125	29436	1950	Ø 110- Ø 130	1350	60
PEX-320-4S	150	29440	2350	Ø 120- Ø 150	1900	90
PEX-360-4S	225	29444	2410	Ø 150- Ø 200	2800	135
PEX-400-4S	300	29452	2940	Ø 200- Ø 250	3900	150

Specifications

Overall Dimensions

Unit : mm

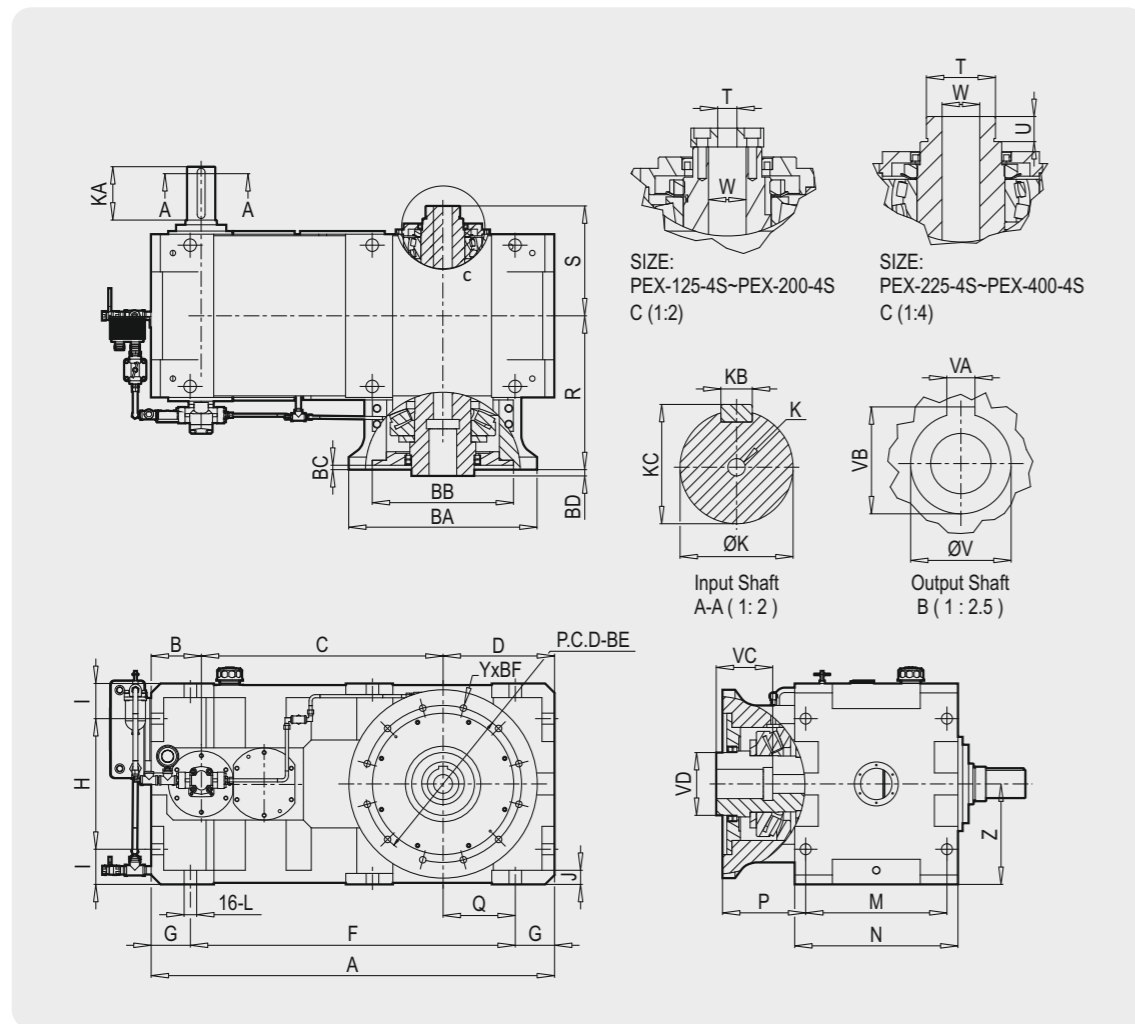

Type	Size	A	B	C	D	E	F	G	H	I	J
PEX-125-4S		525	80	305	140	250	408	50	160	45	17
PEX-140-4S		592	90	342	160	280	459	56.5	184	48	18
PEX-160-4S		665	100	385	180	320	539	63	220	50	21
PEX-180-4S		744	112	432	200	360	604	70	240	60	26
PEX-200-4S		835	125	485	225	400	675	80	260	70	31
PEX-225-4S		935	140	545	250	450	755	90	290	80	36
PEX-250-4S		1050	160	610	280	500	850	100	320	90	42
PEX-280-4S		1180	180	685	315	560	956	112	360	100	48
PEX-320-4S		1285	160	770	355	640	1035	125	416	112	45
PEX-360-4S		1490	225	865	400	710	1210	140	460	125	55
PEX-400-4S		1670	250	970	450	800	1350	160	520	140	60

Type	Size	L(Ø)	M	N	P	Q	R	S	T	U	W(Ø)	Z
PEX-125-4S		Ø 16	180	204	115	90	205	135	M18	50	Ø 22	125
PEX-140-4S		Ø 18	200	226	130	103.5	230	145	M18	56	Ø 25	140
PEX-160-4S		Ø 20	225	256	137.5	117	250	160	M18	63	Ø 30	160
PEX-180-4S		Ø 22	250	286	150	130	275	190	M20	70	Ø 35	180
PEX-200-4S		Ø 24	280	320	180	145	320	245	M85	80	Ø 45	200
PEX-225-4S		Ø 27	315	360	197.5	160	355	270	M85	90	Ø 55	225
PEX-250-4S		Ø 30	355	407	227.5	180	405	300	M85	100	Ø 55	250
PEX-280-4S		Ø 33	400	460	245	203	445	320	M90	112	Ø 60	280
PEX-320-4S		Ø 36	450	520	265	230	490	350	M90	125	Ø 60	315
PEX-360-4S		Ø 39	500	580	310	260	560	390	M120	140	Ø 80	355
PEX-400-4S		Ø 42	560	650	360	290	640	425	M120	160	Ø 80	400

Type	Size	Barrels (customize)						Screw (customize)					Input shaft					
		BA (Ø)	BB (Ø)	BC	BD	BE (Ø)	Y	BF	V (Ø)	VA	VB	VC	VD (Ø)	K (Ø)	KA (Ø)	KB	KC	X
PEX-125-4S		230	180	5	8	205	8	M12	32	10	31.3	80	80	22	56	8	31	M8
PEX-140-4S		260	200	5	8	230	8	M12	38	10	38.3	80	90	24	63	10	35	M8
PEX-160-4S		300	230	6	17	260	8	M16	42	12	48.8	100	110	28	70	10	38	M10
PEX-180-4S		350	260	6	17	300	8	M20	48	14	53.8	110	130	32	80	12	43	M10
PEX-200-4S		380	290	6	18	330	8	M20	60	18	64.3	120	140	40	90	14	48.5	M10
PEX-225-4S		400	310	6	18	350	12	M20	70	20	74.9	140	160	45	100	14	53.5	M12
PEX-250-4S		450	365	8	20	400	12	M24	80	22	85.3	140	170	50	112	16	59	M12
PEX-280-4S		500	400	8	20	450	12	M24	90	25	95.4	140	180	55	125	18	64	M16
PEX-320-4S		600	450	8	20	500	12	M24	100	28	106	140	190	60	140	20	75	M16
PEX-360-4S		680	520	10	24	600	12	M30	110	28	116	160	200	70	160	22	85	M20
PEX-400-4S		750	600	10	24	680	12	M33	125	32	137	180	220	80	180	25	95	M20

For Absolute Solutions

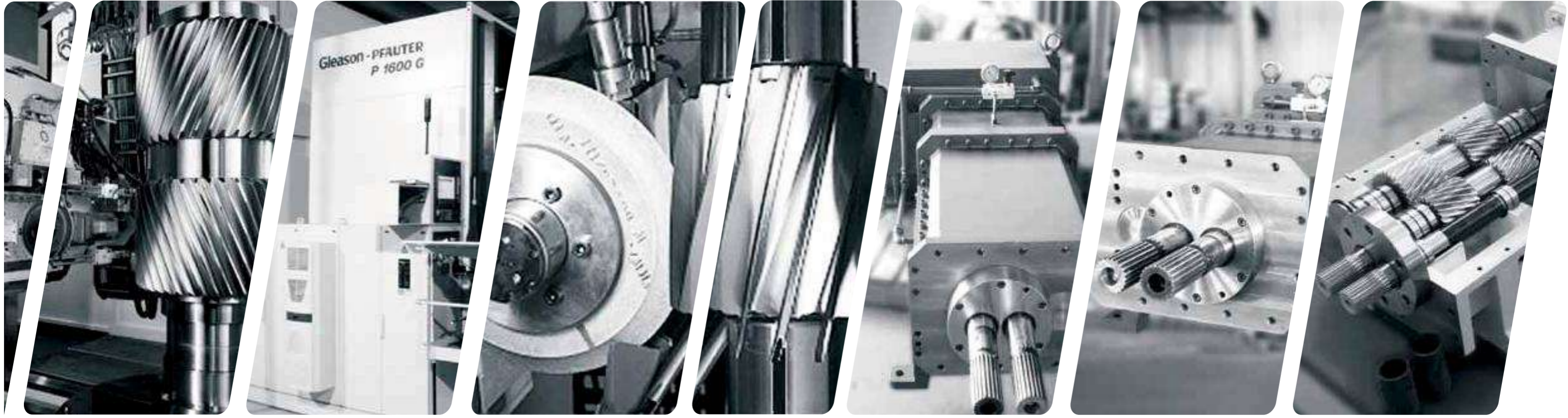

Gearbox for Twin-Screw Extruder

POLAT GROUP REDÜKTÖR SAN. VE TİC.A.Ş.
Ata Mah. Astim OSB 1. Cd. No: 4 Efeler - AYDIN / TÜRKİYE
TEL : 0256 231 19 12 (pbx) FAX : 0256 231 19 17



info@pgr.com.tr
www.pgr.com.tr

Gearbox Selection Process

STEP	Gearbox for Co- Rotating Twin-screw Extruder	Gearbox for Counter-Rotating Twin-screw Extruder	Reference
Step1	<p>SELECT NOMINAL RATIO In $I_{Req} = n1/n2$ Example : $n1 = 1750 \text{ rpm}$; $n2 = 600 \text{ rpm}$ $I_{Req} = 1750/600 = 2.91$ Choose In close I Req ' see Tables 1, In = 3</p>	<p>SELECT NOMINAL RATIO In $I_{Req} = n1/n2$ Example : $n1 = 1000 \text{ rpm}$; $n2 = 50 \text{ rpm}$ $I_{Req} = 1000/50 = 20$ Choose In close I Req ' see Tables 2, In = 20</p>	<p>In = Nominal Ratio I Req = Ratio (required) n1 = Input speed n2 = Driven machine speed</p>
Step2	<p>CALCULATE SINGLE SHAFT OUTPUT TORQUE T Req $T_{Req} = \frac{P \times 9550 \times SF}{2 \times n2} \text{ Nm}$ Example : P = 150 kw ; SF = 1.6 ; n2 = 600rpm $T_{Req} = 150 \times 9550 \times 1.6 / 2 \times 600 = 1910 \text{ Nm}$ For general conditions, our suggestion of SF is 1.6, If you have other different requirement, please contact with our Research & Development Dept.</p>	<p>CALCULATE SINGLE SHAFT OUTPUT TORQUE T Req $T_{Req} = \frac{P \times 9550 \times SF}{2 \times n2} \text{ Nm}$ Example : P = 22.5 kw ; SF = 1.6 ; n2 = 50 rpm $T_{Req} = 22.5 \times 9550 \times 1.6 / 2 \times 50 = 3438 \text{ Nm}$ For general conditions, our suggestion of SF is 1.6, If you have other different requirement, please contact with our Research & Development Dept.</p>	<p>P = Power of Working Machine SF = Service Factor for Driven Machine n2 = Driven machine speed T Req = Torsion of single shaft (required)</p>
Step3	<p>SELECT GEAR UNIT TYPE AND SIZE $T_n > T_{Req}$ Example : T Req = 1910 Nm Gear unit type POR 60/72 with Nominal Torque Tn 3048 Nm $T_n \geq T_{Req}$ POR 60/72 Gear Unit is okay</p>	<p>SELECT GEAR UNIT TYPE AND SIZE $T_n > T_{Req}$ Example : T Req = 3438 Nm Gear unit type PTR-H 55/65 with Nominal Torque Tn 4104 Nm $T_n \geq T_{Req}$ PTR-H 55/65 Gear Unit is okay</p>	<p>Tn = Nominal torsion T Req = Torsion of single shaft (required)</p>
Step4	<p>CALCULATE THRUST LOAD $F_a = \pi \times \frac{ds^2 \times PS}{4 \times 10000} \text{ kN}$ Example : ds = 72 mm ; PS = 150 Bar $F_a = \pi \times \frac{72^2 \times 150}{4 \times 10000} = 61.07 \text{ kN}$</p>	<p>CALCULATE THRUST LOAD $F_a = \pi \times \frac{ds^2 \times PS}{4 \times 10000} \text{ kN}$ Example : ds = 65 mm ; PS = 200 Bar $F_a = \pi \times \frac{65^2 \times 200}{4 \times 10000} = 66.36 \text{ kN}$</p>	<p>ds = Screw Diameter Ps = Pressure on screw Fa = Thrust Load 1 bar = 14.5 Psi</p>
Step5	<p>CALCULATE NOMINAL THRUST BEARING LIFE TIME $L_{h10} = \frac{10^6}{60 \times n2} \times \left(\frac{C_{dyn}}{F_a} \right)^{\frac{10}{3}} \text{ [hr]}$ Example : n2 = 600 rpm ; Cdyn = 471 kN ; Fa = 61.07 kN $L_{h10} = \frac{10^6}{60 \times 600} \times \left(\frac{471}{61.07} \right)^{\frac{10}{3}} = 25177 \text{ [hr]}$ NOMINAL THRUST BEARING LIFE TIME $\geq 25177 \text{ [hr]}$</p>	<p>CALCULATE NOMINAL THRUST BEARING LIFE TIME $L_{h10} = \frac{10^6}{60 \times n2} \times \left(\frac{C_{dyn}}{F_a} \right)^{\frac{10}{3}} \text{ [hr]}$ Example : n2 = 50 rpm ; Cdyn = 471 kN ; Fa = 66.36 kN $L_{h10} = \frac{10^6}{60 \times 50} \times \left(\frac{471}{66.36} \right)^{\frac{10}{3}} = 22904 \text{ [hr]}$ NOMINAL THRUST BEARING LIFE TIME $\geq 22904 \text{ [hr]}$</p>	<p>Lh10 = LIFE TIME n2 = Driven machine speed Cdyn = Dyn.Capacity Thrust Bearing Fa = Thrust Load</p>

Twin-Screw Extruder Features

Twin-screw Extruder - Co-rotating

Double Helical Gear for Torsion.

It is manufactured as a single piece:

- No Axial Thrust Force
- achieves substantially more torque than other alternatives
- 100% Torque Output

Lower The Temperature Effectively

We Set up Cooling Pipe Inside to Lubricate Bearings, Gears and Other Parts It Will Ensure Your Gearbox operating under optimal temperature.

The Oil Cooling System Include complete set

- Oil pump system for forced lubrication
- Oil Pump (Heavy Oil Pump)
- Plate Heat Exchanger
- Oil Filter
- Pressure Gauge
- Oil Distributors
- Pressure switch
- Check Valve
- Lubrication Tube

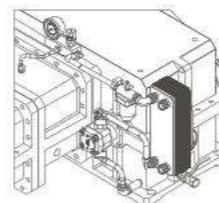

The Spline with Cylinder Grinding

- gives you exceptional precision on positioning
- Minimal hindering on screw operation

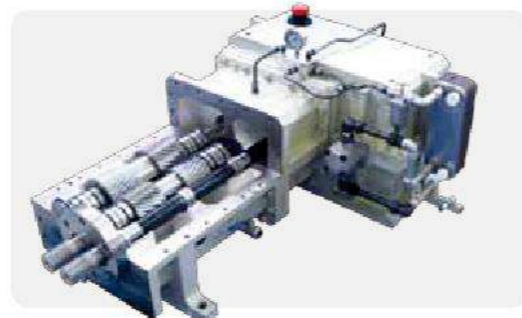
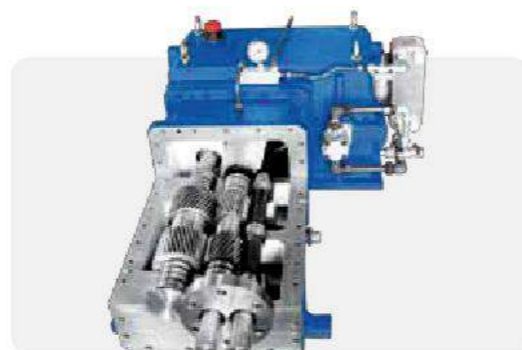

Torque Data Sheet

★ Screw diameter as reference

Unit : mm

Gearbox For Co-rotating Twin-screw Extruder (Table 1)						
Type	Nominal Ratio (In)					
	2	3	5	2	3	5
	[Tn] Each shaft			[N2] Driven machine speed [rpm]		
POR 26 /32 ★	275	277	286	900	600	300
POR 35 /42 ★	475	477	477	900	600	300
POR 48 /58 ★	1534	1547	1585	900	600	300
POR 50 /60 ★	1534	1547	1585	900	600	300
POR 58.5 /70 ★	3049	3048	3151	900	600	300
POR 60 /72 ★	3049	3048	3151	900	600	300
POR 64 /77 ★	3767	3810	3915	800	600	300
POR 76/92 ★	5816	5892	6054	800	600	300
POR 78/95 ★	5816	5892	6054	800	600	300
POR 90/112 ★	-	9683	9970	-	600	300
POR 100/120 ★	-	14468	14916	-	600	300
POR 110/130 ★	-	22283	22385	-	600	300

Gearbox For Co-rotating Twin-screw Extruder (Table 1)						
Type	Nominal Ratio (In)			(Cdyn)	Weight (KG)	Oil Volume (LITER)
	2	3	5			
	(P) Power of Working Machine [kw]			[kN]		
POR 26 /32 ★	52	35	18	73	95	6
POR 35 /42 ★	90	60	30	170	240	13
POR 48 /58 ★	289	194	100	349	415	22
POR 50 /60 ★	289	194	100	349	415	22
POR 58.5 /70 ★	575	388	198	471	760	24
POR 60 /72 ★	575	388	198	471	760	24
POR 64 /77 ★	631	479	246	577	1005	67
POR 76/92 ★	974	740	380	755	1380	92
POR 78/95 ★	974	740	380	755	1380	92
POR 90/112 ★	-	1217	626	1008	1825	82
POR 100/120 ★	-	1818	938	1263	2235	112
POR 110/130 ★	-	2800	1406	1580	4360	210

Overall Dimensions

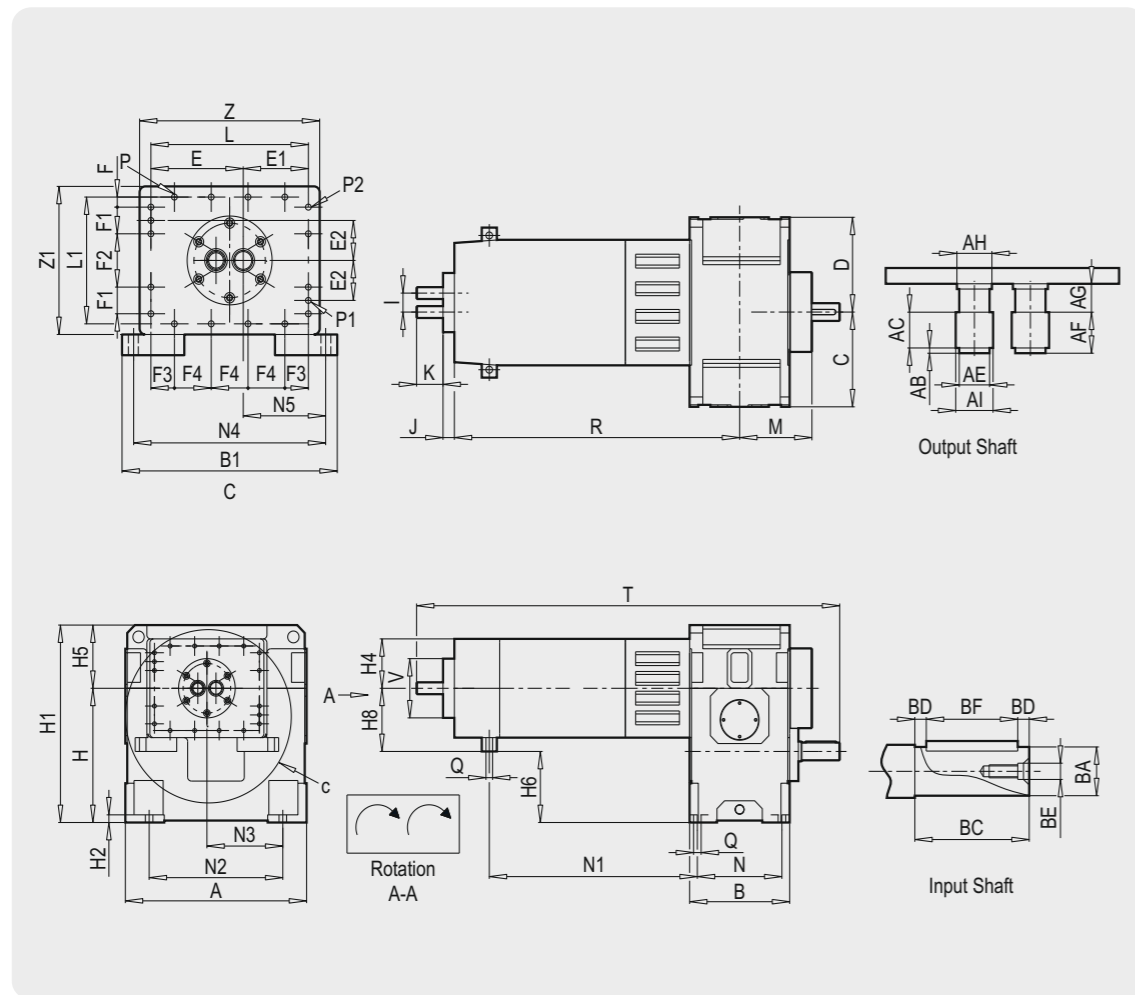

Type \ Size	Barrels Flange (customize)													
	B1	E	E1	E2	F	F1	F2	L	F3	F4	L1	N4	N5	P n° 8
POR-H 26/32 ★	260	95.1	68.9	42	15	30	54	164	22	40	144	235	104.4	M8
POR-H 35/42 ★	280	119	84	54	17	36	72	203	26.5	50	178	250	107.5	M12
POR-H 48/58 ★	380	163	115	67.5	24	45	90	278	41.5	65	228	340	146	M13
POR-H 58.5/70 ★	480	199.25	140.75	82.5	30	55	110	340	35	90	280	425	183.25	M15
POR-H 64/77 ★	520	222	158	90	40	60	120	380	40	100	320	470	203	M17
POR-H 76/92 ★	584	248	172	97.5	40	65	130	420	45	110	340	534	229	M22
POR-H 90/112 ★	618	272	182	97.5	47	65	130	454	62	110	354	560	235	M22
POR-H110/133 ★	845	370	260	157.5	55	105	210	630	52.5	175	530	760	325	M26

Specifications

★ Screw diameter as reference

Unit : mm

Type \ Size	A	B	C	D	H	H1	H2	H3	H4	I	J	K
POR-H 26/32 ★	330	168	100	82.5	112	224	15	15	70	26.2	16	45
POR-H 35/42 ★	405	240	125	100	140	280	18	18	90	35	24	61
POR-H 48/58 ★	522	265	160	125	160	320	27	20	110	48	28	67
POR-H 58.5/70 ★	655	350	200	160	200	400	30	25	130	58.5	30	85
POR-H 64/77 ★	730	375	225	180	225	450	32	25	160	64	37	98
POR-H 76/92 ★	800	415	250	200	250	500	35	29	160	76	28	127
POR-H 90/112 ★	925	520	280	225	280	560	30	35	170	90	30	140
POR-H110/133 ★	1149	450	360	225	360	720	40	48	260	110	48	282

Type \ Size	M	M1	N	N1	N2	N3	Q	R	J	V	Weight (kg)	Oil (kg)
POR-H 26/32 ★	98	100	143	345	305	170	14	445	669	95	80	10
POR-H 35/42 ★	132.5	134	205	493	370	208	18	628.5	927.5	120	220	15
POR-H 48/58 ★	164	165	225	643	482	265	20	795.5	1155.5	150	380	20
POR-H 58.5/70 ★	208	210	300	762	605	335	24	952	1402	180	680	40
POR-H 64/77 ★	229	230	325	802	680	380	26	1010	1499.5	200	910	60
POR-H 76/92 ★	260.5	262	365	977	750	425	26	1210	1756.5	220	1215	70
POR-H 90/112 ★	295	295	466	984	870	478	28	1287	1933	260	1870	105
POR-H110/133 ★	271	285	360	1609	1089	555	30	2054	2869	330	4360	210

P1 H7	P2 n° 8	Z	Z1	Output shaft							Input shaft				
				AI (DIN5482)	AB	AC	AE	AH	AF	AG	BA	BC	BD	BE	BF
8	M8	180	160	17x14	4	21	12	14	25	-	28m6	63	6.5	M8	50
10	M12	225	200	22x19	5	35	19	20	30	18	35m6	80	10	M8	60
10	M12	300	250	32x28	5	34	26	30	39	22	45m6	100	10	M10	80
12	M14	370	320	40x36	6	42	35	38	48	27	55m6	125	13	M12	100
16	M16	410	350	48x44	6	50	42	44	56	30	55m6	125	13	M12	100
16	M20	460	380	60x55	8	50	53	54	58	52	60m6	130	10	M12	110
16	M20	500	400	62x57	8	62	55	57	70	50	80m6	180	10	M16	160
20	M24	680	580	80x74	10	90	70	75	100	60	90m6	200	10	M16	180

Overall Dimensions

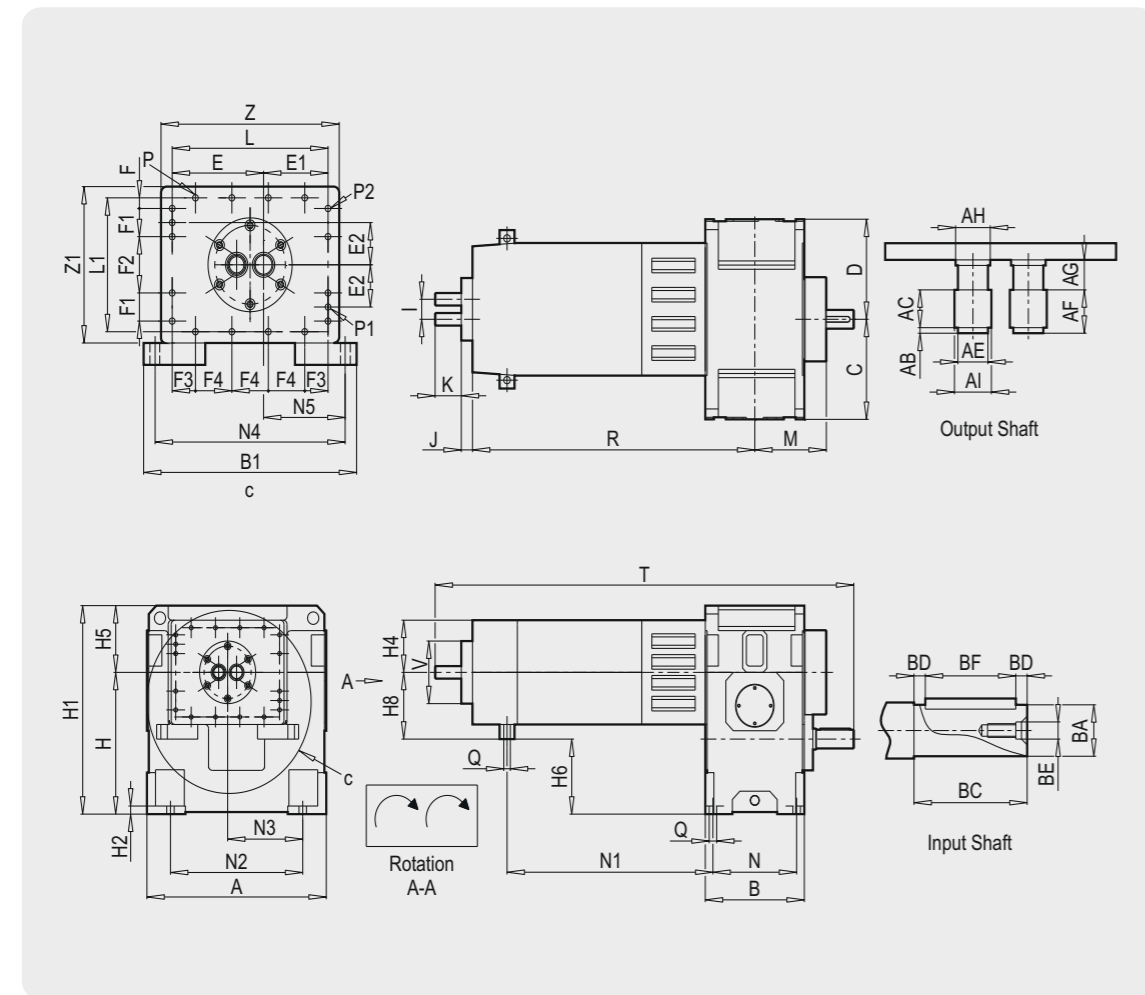

Type	Size	Barrels Flange (customize)													
		B1	E	E1	E2	F	F1	F2	L	F3	F4	L1	N4	N5	P1 n° 8
POR-V 26/32★		260	95	69	42	15	30	54	164	22	40	144	235	104	M8
POR-V 35/42★		280	119	84	54	17	36	72	203	27	50	178	250	108	M12
POR-V 48/58★		380	163	115	67.5	24	45	90	278	42	65	228	340	146	M13
POR-V 50/60★		380	163	115	67.5	24	45	90	278	42	65	228	340	146	M13
POR-V 58.5/70★		480	199	141	82.5	30	55	110	340	35	90	280	425	183	M15
POR-V 60/72★		480	199	141	82.5	30	55	110	340	35	90	280	425	183	M15
POR-V 64/77★		520	222	158	90	40	60	120	380	40	100	320	470	203	M17
POR-V 76/92★		584	248	172	97.5	40	65	130	420	45	110	340	534	229	M22
POR-V 78/95★		584	248	172	97.5	40	65	130	420	45	110	340	534	229	M22
POR-V 90/112★		618	272	182	97.5	47	65	130	454	62	110	354	560	235	M22
POR-V100/120★		-	310	210	112.5	50	75	150	520	65	130	400	325	85	M24
POR-V110/133★		845	370	260	157.5	55	105	210	630	53	175	530	760	325	M26

Specifications

★ Screw diameter as reference

Unit : mm

Type	Size	A	B	C	D	H	H1	H2	H4	H5	H6	H8	I	J
POR-V 26/32★		300	168	150	150	212	324	16	70	112	100	112	26	16
POR-V 35/42★		380	225	190	190	265	405	20	90	140	125	140	35	24
POR-V 48/58★		480	265	240	240	340	500	23	110	160	180	160	48	28
POR-V 50/60★		480	265	240	240	340	500	23	110	160	180	160	50	28
POR-V 58.5/70★		590	350	295	295	425	650	31	130	225	225	200	59	30
POR-V 60/72★		590	350	295	295	425	650	31	130	225	225	200	60	30
POR-V 64/77★		650	375	325	325	475	725	35	160	250	250	225	64	37
POR-V 76/92★		700	415	350	350	530	810	40	160	280	280	250	76	28
POR-V 78/95★		700	415	350	350	530	810	40	160	280	280	250	78	28
POR-V 90/112★		665	485	325	325	555	835	45	170	280	275	280	90	30
POR-V100/120★		710	485	355	355	596	876	45	195	280	371	225	100	30
POR-V110/133★		-	-	-	-	-	-	-	260	-	-	360	110	48

Type	Size	K	M	N	N1	N2	N3	Q	R	T	V	Weight (kg)	Oil (kg)
POR-V 26/32★		45	100	138	288.5	210	105	14	445	669	95	95	6
POR-V 35/42★		61	134	190	413.5	268	134	18	628.5	927.5	120	240	13
POR-V 48/58★		67	165	224	551	354	177	20	795.5	1115.5	150	415	22
POR-V 50/60★		67	165	224	551	354	177	20	795.5	1115.5	150	415	22
POR-V 58.5/70★		85	210	310	644	450	225	24	952	1402	180	760	24
POR-V 60/72★		85	210	310	644	450	225	24	952	1402	180	760	24
POR-V 64/77★		98	230	325	672	490	245	26	1009.5	1499.5	200	1005	67
POR-V 76/92★		127	262	355	840	500	250	26	1209.5	1756.5	220	1380	92
POR-V 78/95★		127	262	355	840	500	250	26	1209.5	1756.5	220	1380	92
POR-V 90/112★		140	289	431	879	475	192	28	1319.5	2028	260	1825	82
POR-V100/120★		180	303	430	1172.5	520	210	29	1652.5	2345	280	2235	112
POR-V110/133★		282	-	-	-	-	-	30	2054	2869	330	-	-

P1 H7	P2 n° 8	Z	Z1	Output shaft						Input shaft					
				AI (DIN5482)	AB	AC	AE	AH	AF	AG	BA	BC	BD	BE	BF
8	M8	180	160	17 x 14	4	21	12	-	25	-	28m6	63	6.5	M8	50
10	M12	225	200	22 x 19	5	35	19	20	30	18	35m6	80	10	M8	60
10	M12	300	250	32 x 28	5	34	26	30	39	22	45m6	100	10	M10	80
10	M12	300	250	32 x 28	5	34	26	30	39	22	45m6	100	10	M10	80
12	M14	370	320	40 x 36	6	42	35	38	48	27	55m6	125	13	M12	100
12	M14	370	320	40 x 36	6	42	35	38	48	27	55m6	125	13	M12	100
16	M16	410	350	48 x 44	6	50	42	44	56	30	55m6	125	13	M12	100
16	M20	460	380	60 x 55	8	50	53	54	58	52	60m6	130	10	M12	110
16	M20	460	380	60 x 55	8	50	53	54	58	52	60m6	130	10	M12	110
16	M20	500	400	62 x 57	8	62	55	57	70	50	80m6	180	10	M16	160
20	M24	570	450	72 x 66	10	90	60	65	100	57	80m6	180	10	M16	160
20	M24	-	-	80 x 74	10	90	70	75	100	60	90m6	200	10	M16	180

Twin-Screw Extruder Features

Twin-screw Extruder - Counter-rotating

Double Helical Gear for Torsion.

- It is manufactured as a single piece:
- No Axial Thrust Force
 - achieves substantially more torque than other alternatives
 - 100% Torque Output

Lower The Temperature Effectively

We Set up Cooling Pipe Inside to Lubricate Bearings, Gears and Other Parts It Will Ensure Your Gearbox operating under optimal temperature.

The Oil Cooling System Include complete set

- Oil pump system for forced lubrication
- Oil Pump (Heavy Oil Pump)
- Plate Heat Exchanger
- Oil Filter
- Pressure Gauge
- Oil Distributors
- Pressure switch
- Check Valve
- Lubrication Tube

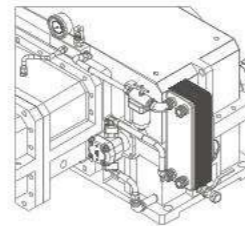

The Spline with Cylinder Grinding

- Gives you exceptional precision on positioning
- Minimal hindering on screw operation



Torque Data Sheet

★ Screw diameter as reference

Unit : mm

Gearbox For Counter-rotating Twin-screw Extruder (Table 2)

Type	Nominal Ratio (In)	[Tn] Each shaft	[N2] Driven machine speed [rpm]
PTR 44/55 ★	20	1527	50
PTR 55/65 ★	20	4104	50
PTR 64/75 ★	20	6211	50
PTR 75/90 ★	20	10080	45
PTR 90/107 ★	20	17308	45
PTR 110/130 ★	20	31680	40
PTR 130/160 ★	20	47367	40

Gearbox For Counter-rotating Twin-screw Extruder (Table 2)

Type	(P) Power of Working Machine [kw]	(Cdyn) [kN]	Weight [KG]	Oil Volume [LITER]
PTR 44/55 ★	13	349	290	18
PTR 55/65 ★	36	471	656	32
PTR 64/75 ★	54	577	805	47
PTR 75/90 ★	79	755	1065	67
PTR 90/107 ★	122	1008	2185	97
PTR 110/130 ★	181	1580	3250	135
PTR 130/160 ★	331	1992	5655	182

Specifications

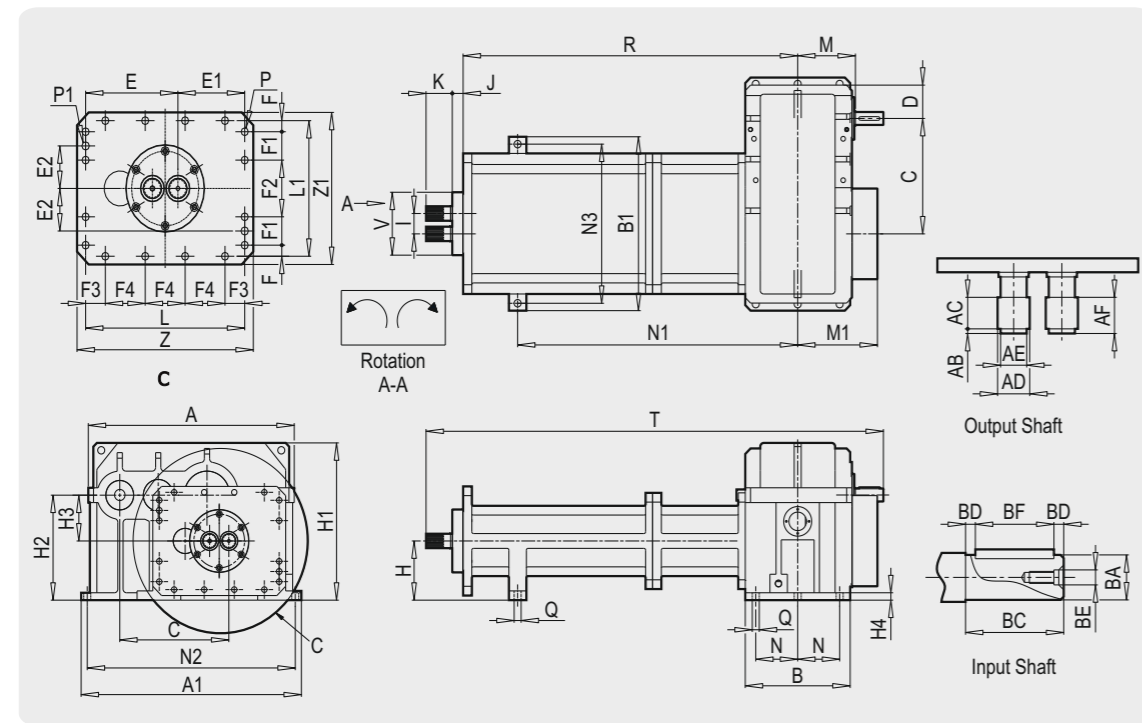

Type \ Size	R	T	V	M	M1	N	Shaft	
							BA	BC
PTR-H 44/55★	683	970.5	150	137.5	200	92.5	32m6	70
PTR-H 55/65★	957	1308	170	165	226	120	35m6	80
PTR-H 64/75★	992	1402	195	190	260	135	40m6	90
PTR-H 75/90★	1168	1623	220	215	305	150	45m6	100
PTR-H 90/107★	1320	1850	260	240	352	180	60m6	140
PTR-H110/130★	1520	2198	300	325	410	225	75m6	160
PTR-H130/160★	2160	3075	380	465	515	265	80m6	180

Type \ Size	Barrels (customize)					
	E	E1	E2	F	F4	L
PTR-H 44/55★	165	121	67.5	15	75	286
PTR-H 55/65★	199	144	82.5	21.5	86	343
PTR-H 64/75★	224	160	84	25	95	384
PTR-H 75/90★	256.5	181.5	90	34	110	438
PTR-H 90/107★	272	182	97.5	47	110	454
PTR-H110/130★	330	220	135	50	130	550
PTR-H130/160★	405	275	165	60	160	680

Overall Dimensions

★ Screw diameter as reference

Unit : mm

Type \ Size	A	A1	B	B1	C	D	H	H1	H2
PTR-H 44/55★	495	525	245	390	265	80	125	362	237
PTR-H 55/65★	589	630	300	470	312	90	160	425	283.7
PTR-H 64/75★	640	710	340	500	355.5	100	160	465	305
PTR-H 75/90★	735	800	380	560	401	125.5	180	521	341
PTR-H 90/107★	910	940	450	618	503.5	157.5	220	614.5	416.5
PTR-H110/130★	1100	1155	550	750	637.5	180	280	815	535
PTR-H130/160★	1220	1380	730	900	715	200	320	930	610

Type \ Size	H3	H4	I	J	K	N1	N2	N3	Q
PTR-H 44/55★	112	20	44	20	60	553	496	350	16
PTR-H 55/65★	123.7	20	55	31	75	801	595	430	20
PTR-H 64/75★	145	26	64	44	86	832	672	465	20
PTR-H 75/90★	161	28	75	30	110	993	760	520	22
PTR-H 90/107★	196.5	35	90	57	93	1120	890	568	26
PTR-H110/130★	255	45	110	33	160	1290	1090	685	30
PTR-H130/160★	290	50	130	68	202	1885	1320	840	32

Input Shaft			Output Shaft				
BD	BE	BF	AD (DIN 5480)	AB	AC	AE	AF
5	M8	60	W28 x 1.5 x 30 x 17	6.5	28.5	24	35
10	M10	60	W40 x 1.5 x 30 x 25	6	44	30	50
10	M10	70	W45 x 2 x 30 x 21	6	44	40	50
10	M10	80	W55 x 3 x 30 x 17	8	53	48.5	60
10	M12	120	W65 x 2.5 x 30 x 24	8	62	50	70
10	M16	140	W75 x 2 x 30 x 36	6.5	73.5	70	76.5
10	M16	160	W85 x 3 x 30 x 27	8	105	78	113

Barrels (customize)							
L1	P	P1	Z	F1	F2	F3	Z1
210	M12	12	310	45	90	30.5	240
263	M18	16	380	55	110	42.5	295
274	M16	16	420	56	112	49.5	305
308	M20	16	475	60	120	54	345
354	M22	16	500	65	130	62	400
460	M24	16	600	90	180	80	510
560	M30	20	740	110	220	100	620

Specifications

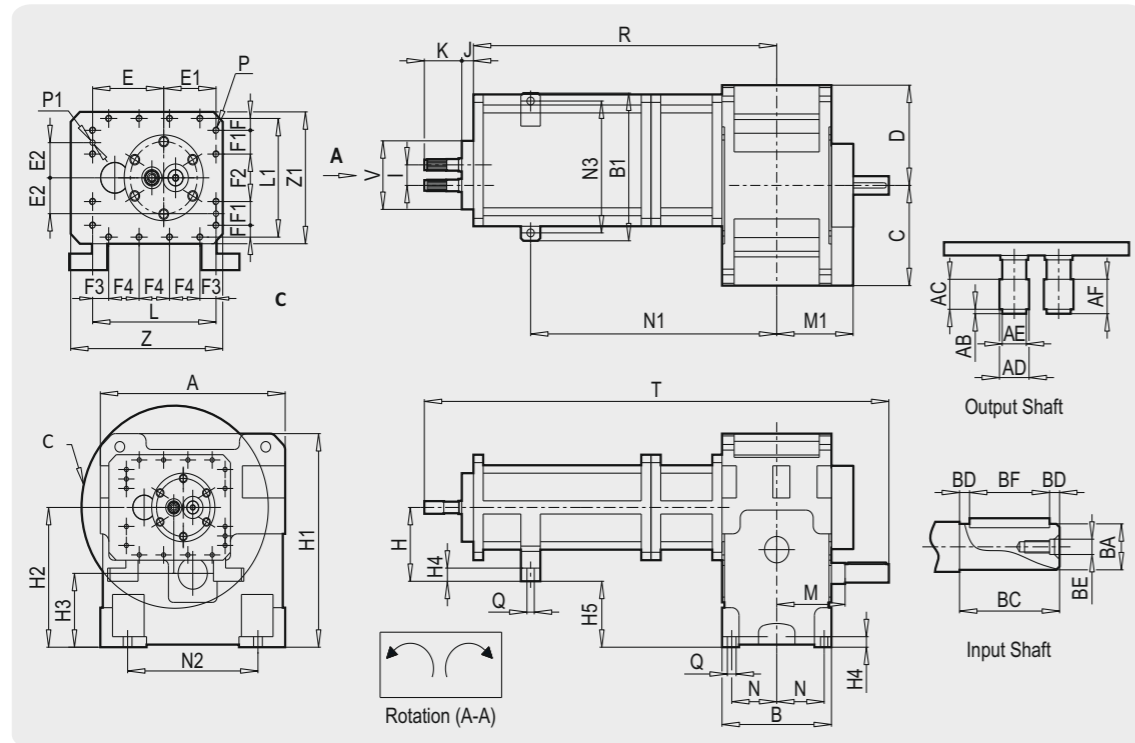

Type \ Size	R	T	V	M	M1	N	Shaft	
							BA	BC
PTR-V 55/65 ★	957	1330	170	145	220	127	28	80
PTR-V 64/75 ★	1044.5	1427	195	176.5	252.5	142.5	32m6	70
PTR-V 75/90 ★	1223	1655.5	220	190	292.5	157.5	35m6	80
PTR-V 90/107 ★	1535	2132.5	270	275	417.5	227.5	45m6	100
PTR-V 110/130 ★	1821	2518	300	297	447	189	50m6	112

Type \ Size	Barrels (customize)					
	E	E1	E2	F	F4	L
PTR-V 55/65 ★	199	144	82.5	21.5	86	343
PTR-V 64/75 ★	224	160	84	25	95	384
PTR-V 75/90 ★	256.5	181.5	90	34	110	438
PTR-V 90/107 ★	272	182	97.5	47	110	454
PTR-V 110/130 ★	330	220	135	50	130	550

Overall Dimensions

★ Screw diameter as reference

Unit : mm

Type \ Size	A	B	B1	C	D	H	H1	H2	H3
PTR-V 55/65 ★	400	290	470	157.5	242.5	160	610	477.5	125
PTR-V 64/75 ★	465	325	500	178	287	160	695	542.5	140
PTR-V 75/90 ★	520	360	560	200	320	180	770	597.5	160
PTR-V 90/107 ★	660	515	618	264.5	395.5	175	948	723	180
PTR-V 110/130 ★	710	564	750	232.5	477.5	230	1005	765	200

Type \ Size	H4	I	J	K	N1	N2	N3	Q
PTR-V 55/65 ★	25	55	31	75	848	300	430	20
PTR-V 64/75 ★	21	64	44	86	884.5	355	465	20
PTR-V 75/90 ★	26	75	30	110	1048	400	520	22
PTR-V 90/107 ★	33	90	50	130	1305	500	620	31
PTR-V 110/130 ★	35	110	55	195	1591	652	587	32

Input Shaft			Output Shaft				
BD	BE	BF	AD (DIN 5480)	AB	AC	AE	AF
5	M8	60	W40 x 1.5 x 25	6	44	30	50
5	M8	60	W45 x 2 x 21	6	44	40	50
10	M10	60	W55 x 3 x 17	8	53	48.5	60
10	M12	80	W65 x 2 x 31	8	62	50	70
10	M12	120	W78 x 2 x 38	6.5	73.5	70	76.5

Barrels (customize)							
L1	P	P1	Z	F1	F2	F3	Z1
263	M18	16	380	55	110	42.5	295
274	M16	16	420	56	112	49.5	305
308	M20	16	475	60	120	54	345
354	M22	16	500	65	130	62	400
460	M24	16	600	90	180	80	510