



PH/PB SERIES

Endüstriyel Tip Redüktörler

Industrial Type Gear Units

Schwerlastgetriebe

IE2 | IE3



Katalođumuzda yer alan bilgileri, önceden haber vermeksizin kısmen veya tamamen deđiřtirme veya iptal etme hakkını saklı tutmaktayız /

We reserve the right to our company to make changes or modifications to catalogue without prior notice /

Eine änderung in diesem Katalog der Technischen Werte sowie Daten und Maßen und Gewichte bleiben vorbehalten.

PGR[®]
DRIVE TECHNOLOGIES

İÇİNDEKİLER / CONTENTS / INHALT

TEMEL TİPLER / SUMMARY OF BASIC TYPES / BAUARTENÜBERSICHT	4-5
KARAKTERİSTİK ÖZELLİKLER / CHARACTERISTIC FEATURES / CHARAKTERISTISCHE VERZÜGE	6
GENEL BİLGİLER / GENERAL INFORMATION / ALLGEMEINE HINWEISE	7
REDÜKTÖR SEÇİMİNDE DİKKAT EDİLMESİ GEREKENLER / GUIDELINES FOR THE SELECTION CONSTANT MECHANICAL POWER RATING / RICHTLINIEN FÜR DIE AUSWAHL KONSTANTE LEISTUNG MECHANISCH	8
TERMAL KAPASİTE SEÇİMİ İÇİN KURALLAR / GUIDELINES FOR THE SELECTION THERMAL CAPACITIES / RICHTLINIEN FÜR DIE AUSWAHL KONSTANTE LEISTUNG THERMISCH	9
DEĞİŞKEN GÜÇ SEÇİMİ İÇİN KURALLAR / GUIDELINES FOR THE SELECTION VARIABLE POWER RATING / RICHTLINIEN FÜR DIE AUSWAHL VARIABLE LEISTUNG ..	10
REDÜKTÖR SEÇİMİNDE ÖRNEK MEKANİK GÜÇ DEĞERİ HESAPLANMASI İÇİN KURALLAR / GUIDELINES FOR THE SELECTION CALCULATION EXAMPLE MECHANICAL POWER RATING / RICHTLINIEN FÜR DIE AUSWAHL BERECHNUNGSBEISPIEL MECHANISCH	11
SEMBOLLER / KEY TO SYMBOLS / ERKLÄRUNG DER BEZEICHNUNGEN	12
TERMAL KAPASİTE SEÇİMİ İÇİN HESAPLAMA ÖRNEĞİ KURALLAR / GUIDELINES FOR THE SELECTION CALCULATION EXAMPLE THERMAL CAPACITY RICHTLINIEN FÜR DIE AUSWAHL BERECHNUNGSBEISPIELTHERMISCH	13
SERVİS FAKTÖRÜ / SERVICE FACTORS / BETRIEBSFAKTOREN	14-16
SEÇİM TABLOLARI / SELECTION OF GEAR UNIT / AUSWAHL DES GETRIEBES	
TERMAL KAPASİTELER VE NOMİNAL GÜÇ DEĞER TABLOLARI / THERMAL CAPACITIES AND NOMINAL POWER RATINGS TABLES WÄRMEGRENZLEISTUNGEN, NENNLEISTUNGEN TABELLE	17-55
GERÇEK TAHVİLLER / ACTUAL RATIOS / IST - ÜBERSETZUNGEN	56-59
ÇIKIŞ MİLİ ÜZERİNDE İZİN VERİLEN RADYAL KUVVETLER / PERMISSIBLE ADDITIONAL RADIAL FORCES ON OUTPUT SHAFT ZULÄSSIGE RADIALE ZUSATZKRÄFTE AN ABTRIEBSWELLE	60-61
KÜTLE ATALET MOMENTİ / MASS MOMENTS OF INERTIA / MASSENTRÄGHEITSMOMENTE	62-65
MONTAJLAR / ASSEMBLIES / AUSFÜHRUNGSFORMEN	66-67
ÖLÇÜ TABLOLARI / DIMENSIONS TABLES / GRÖÖE TABELLEN	
PH YATAY / PH HORIZONTAL / PH HORIZONTAL	69-83
KİLİT / BACKSTOP / RÜCKLAUFSPERRE	84
PB YATAY / PB HORIZONTAL / PB HORIZONTAL	85-97
KİLİT / BACKSTOP / RÜCKLAUFSPERRE	98
PH DİKEY / PH VERTICAL / PH VERTIKAL	99-111
POMPA / PUMP / PUMPE	112
PB DİKEY / PB VERTICAL / PB VERTIKAL	113-125
POMPA / PUMP / PUMPE	126
MİL UCU MERKEZİ DELİKLERİ FORMU DS DIN 32/2 / CENTER HOLES, FORM DS IN SHAFT ENDS DIN 32 / ZENTRIERBOHRUNGEN FORM DS IN WELLENENDEN DIN 32/2	127
ISO'YA GÖRE UYGUN KAMA VE KAMA KANALININ SEÇİLMESİ / SELECTION OF ISO FITS PARALLEL KEY AND KEYWAYS / PASSUNGS-AUSWAHL PASSEDERN UND NUTEN	128
KONİK SIKTIRMALI ŞAFTLAR / HOLLOW SHAFTS FOR SHRINK DISCS / HOHLWELLEN FÜR SCHRUMPFSCHEIBEN	129-130
KAMA KANALLI ŞAFTLAR / HOLLOW SHAFTS FOR PARALLEL KEY CONNECTIONS / HOHLWELLEN FÜR PASSFEDERVERBİNDUNGEN	131-132
DELİK MİLLİ SPLİNE ŞAFLAR DIN 5480 / HOLLOW SHAFT WITH INVOLUTE SPLINES ACC. TO DIN 5480 / HOHLWELLEN MIT ZAHNNABENPROFIL NACH DIN 5480	133-134
FLANŞLI MONTAJ İÇİN MÜŞTERİ FLANŞI / COUNTERFLANGES FOR FLANGED SHAFTS / GEGENFLANSCH FÜR FLANSCHWELLE	135-136
YAĞ SEÇİMİ VE KORUNMASI / SELECTION OF OIL AND PRESERVATION / ÖLAUSWAHL UND KONSERVIERUNG	137
YAĞLAMA TİPLERİ / OİL SUPPLY SURVEY OF VARIANTS / ÖLVERSORGUNG VARIANTENÜBERSICHT	138
DALDIRMA YÖNTEMİYLE YAĞLAMA - DİKEY / DIP LUBRICATION - VERTICAL / TAUCHSCHMIERUNG - VERTIKAL	139
BASINÇLI YAĞLAMA - FLANŞLI POMPA / FORCED LUBRICATION - FLANGED ON PUMP / DRUCKSCHMIERUNG - FLANSCHPUMPE	140-141
BASINÇLI YAĞLAMA - MOTORLU POMPA / FORCED LUBRICATION MOTOR PUMP / DRUCKSCHMIERUNG MOTORPUMPE	142
BASINÇLI YAĞLAMA - KONTROL CİHAZLARI / FORCED LUBRICATION MONITORING INSTRUMENTS / DRUCKSCHMIERUNG ÜBERWACHUNGSGERÄTE	143
BASINÇLI YAĞLAMA - YATAY / FORCED LUBRICATION - HORIZONTAL / DRUCKSCHMIERUNG HORIZONTAL	144-146
SULU YAĞ SOĞUTUCUSU - YATAY / WATER OIL COOLER - HORIZONTAL / WASSER ÖLKÜHLER - HORIZONTAL	147-150
HAVALI YAĞ SOĞUTUCUSU - YATAY / AIR OIL COOLER - HORIZONTAL / LUFT ÖLKÜHLER - HORIZONTAL	151-156
ISITICI / WITH HEATING ELEMENTS / MIT HEIZSTÄBEN	157
YAĞ SICAKLIĞININ ÖLÇÜMÜ İÇİN TERMOMETRELİ MODELLER / WITH THERMOMETER FOR OIL TEMPERATURE / MIT ÖLTEMPERATURMESSUNG	158

İÇİNDEKİLER / CONTENTS / INHALT

ŞAFT KEÇELERİ / SHAFT SEALS / WELLENABDICHTUNGEN	159
ŞAFT KEÇELERİ - DÖNER MİL KEÇESİ - LABİRENT KEÇELER / SHAFT SEALS - RADIAL SHAFT SEAL - LABYRINTH SEALS / WELLENABDICHTUNGEN - RADIALWELLENDICHTRINGE - LABYRINTHDICHTUNGEN	160
ŞAFT KEÇELERİ - TAKONİTE KEÇE / SHAFT SEALS - TACONITE SEALS / WELLENABDICHTUNGEN - TACTONITE DICHTUNGEN.....	161
IEC STANDARTINDAKİ MOTORLAR İÇİN ÖLÇÜLER / FITTING DIMENSION FOR IEC STANDARD MOTORS / ANBAUMABE FÜR IEC-NORMMOTOREN	162
KAPLİN B - IEC BAĞLANTILI MOTORLAR / MOTOR BELLHOUSING FOR IEC STANDARD MOTORS WITH B COUPLING MOTORLATERNE FÜR IEC - MOTOREN MIT B KUPPLUNG	163-174
KAPLİN N - IEC BAĞLANTILI MOTORLAR / MOTOR BELLHOUSING FOR IEC STANDARD MOTORS WITH N COUPLING / MOTORLATERNE FÜR IEC MOTOREN MIT N KUPPLUNG	175-186
REDÜKTÖR GÖVDELERİ İÇİN TİTREŞİM AZALTAN TORK KOLLARI / VIBRATION REDUCING - TORQUE REACTION ARMS FOR -GEAR HOUSINGS / SCHWINGUNGSDÄMPFENDE DREHMOMENTSTÜTZEN FÜR GETRIEBEGEHÄUSE	187-188
KAPLİN N, IEC MOTORLU, KAPLİN BAĞLANTILI VE FRENLİ REDÜKTÖRLER / GEAR UNIT SWING-BASES WITH N COUPLINGS, IEC MOTORS AND ASSIGNED COUPLINGS AND BREAKES / GETRIEBESCHWINGEN MIT N KUPPLUNGEN, IEC-MOTOREN UND ZUGEORDNETEN KUPPLUNGEN UND BREMSEN	189
KAPLİN N REDÜKTÖRLER / GEAR UNIT SWING-BASES WITH N COUPLINGS / GETRIEBESCHWINGEN MIT N KUPPLUNGEN	190-195
KAPLİN F, IEC MOTORLU, KAPLİN BAĞLANTILI VE FRENLİ REDÜKTÖRLER / GEAR UNIT SWING-BASES WITH F FLUID COUPLINGS, IEC MOTORS AND ASSIGNED COUPLINGS AND BREAKES / GETRIEBESCHWINGEN MIT F STRÖMUNGSKUPPLUNGEN, IEC-MOTOREN UND ZUGEORDNETEN KUPPLUNGEN UND BREMSEN	196-197
KAPLİN F BAĞLANTILI REDÜKTÖRLER / GEAR UNIT SWING-BASES WITH FLUDEX FLUID COUPLINGS GETRIEBESCHWINGEN MIT F STRÖMUNGSKUPPLUNGEN..	198-202
ÖZEL MONTAJ POZİSYONLARI / SPECIAL MOUNTING POSITIONS / SONDEREINBAULAGEN	203
REDÜKTÖR TABAN AYAĞININ ÖZEL MONTAJ DURUMLARI / SPECIAL MOUNTING POSITIONS HOUSING BASE RAILS SONDEREINBAULAGEN GETRIEBEFUßLEISTEN	204
SU TESİSATI TASARIMI / FOR WATER SCREWS / WASSERSCHNECKENAUSFÜHRUNG	205-206
MOTOR PLATFORMU - YATAY / MOTOR BRACKETS - HORIZONTAL / MOTORSTÜHLE - HORIZONTAL	207-214
FLANŞ MONTAJI (UZUN) / MOUNTING FLANGE (LONG SPACER) / KRAGENFLANSCH	215-216
FLANŞ MONTAJI (KISA) / MOUNTING FLANGE (SHORT SPACER) / BLOCKFLANSCH	217-218
FAN SOĞUTMASI - SOĞUTMA BOBİNİ / FAN COOLING - COOLING COIL / LUFTERKUHLUNG - KUHLSCHLANGE.....	219
ISITICILAR - BASINÇLI YAĞLAMA - MOTOR POMPASI / HEATERS - FORCED LUBRICATION - MOTOR PUMP / HEIZSTÄBEN - DRUCKSCHMIERUNG - MOTORPUMPE....	220
YARDIMCI TAHRİKLİ REDÜKTÖRLER / BUCKET ELEVATOR DRIVES / BECHERWERKSANTRIEBE	221- 223
TEMEL TİPLER / SUMMARY OF BASIC TYPES / BAUARTENÜBERSICHT	224
KARAKTERİSTİK ÖZELLİKLER / CHARACTERISTIC FEATURES / CHARAKTERISTISCHE VORZÜGE	225
GENEL BİLGİLER / GENERAL INFORMATION / ALLGEMEINE HINWEISE	226
REDÜKTÖR SEÇİMİ İÇİN KURALLAR / GUIDELINES FOR THE SELECTION / RICHTLINIEN FÜR DIE AUSWAHL	227
SEMBOLLER / KEY TO SYMBOLS / ERKLÄRUNG DER BEZEICHNUNGEN	228
ÖRNEK SEÇİM HESABI / GUIDELINES FOR THE SELECTION CALCULATION EXAMPLE / RICHTLINIEN FÜR DIE AUSWAHL BERECHNUNGSBEISPIEL	229
SERVİS FAKTÖRÜ / SERVICE FACTOR / BETRIEBSFAKTORE	230
NOMİNAL GÜÇ DEĞERLERİ / NOMINAL POWER RATINGS / NENNLEISTUNGEN	231
TERMAL KAPASİTELER / THERMAL CAPACITIES / WÄRMEGRENZLEISTUNGEN	232-233
NOMİNAL ÇIKIŞ MOMENTİ / NOMIMAL OUTPUT TORQUES / NENN-ABTRIEBSDREHMOMENTE	234-235
ÜÇ KADEMELİ YARDIMCI REDÜKTÖR / THREE STAGE WITH AUXILIARY DRIVE / DREISTUFIG MIT HILFSANTRIEB	236-243
MİL UCU MERKEZİ DELİKLERİ FORMU DS DIN332/2 / CENTER HOLES, FORM DS IN SHAFT ENDS DIN 332/2 / ZENTRIERBOHRUNGEN FORM DS IN WELLENENDEN DIN 332/2	244
ISO'YA GÖRE UYGUN KAMA VE KAMA KANALININ SEÇİLMESİ / SELECTION OF ISO FITS PARALLEL KEY AND KEYWAYS / PASSUNGS-AUSWAHL PASSFEDERN UND NUTEN	245
DELİK MİLLİ KONİK SIKTIRMALI ŞAFTLAR / HOLLOW SHAFT FOR SHRINK DISKS / HOHLWELLEN FÜR SCHRUMPFCEIBEN.....	246
DELİK MİLLİ KAMA BAĞLANTILI ŞAFTLAR / HOLLOW SHAFTS FOR PARALLEL KEY CONNECTIONS / HOHLWELLEN FÜR PASSFEDERVERBINDUNGEN	247
KİLİT / BACKSTOPS / RÜCKLAUFSPERREN	248-249
GERÇEK TAHVİLLER / ACTUAL RATIOS / IST-ÜBERSETZUNGEN	250
KÜTLE ATALET MOMENTİ J1 / MASS MOMENTS OF INERTIA J1 / MASSENTRÄGHEITSMOMENTE J1	251
TALEP EDİLDİĞİNDE EKLENEBİLEN SEÇENEKLER / ADDITIONAL VARIANTS INFORMATION ON REQUEST / ZUSÄTZLICHE VARIANTEN INFORMATIONEN AUF ANFRAGE	252
ISITMA ELEMANI - HIZ GÖSTERGESİ / HEATING ELEMENT SPEED MONITOR / HEIZKÖRPER DREHZAHLLÜBERWACHUNG	253

TR

KALİTE POLİTİKAMIZ

POLAT GROUP REDÜKTÖR A.Ş. ürünlerinin kalitesinde en iyiyi yakalamak için; sektöründeki teknolojik gelişmeleri takip etmeyi, pazar payındaki istikrarını sürdürmek için müşterilerinin istek ve beklentilerine eksiksiz ve zamanında cevap vererek, sürekli artan müşteri memnuniyetini sağlamayı, eğitilmiş çalışanlarının performansını huzurlu bir çalışma ortamı sağlayarak arttırmayı ve bu şekilde kalite yönetim sistemini sürekli iyileştirmeyi kalite politikası olarak benimsemiştir.

VİZYONUMUZ

Müşteri ve çalışan memnuniyetini en üst düzeyde tutan, gelişmeleri izleyen değil yaratan bir dünya şirketi olmaktır.

MİSYONUMUZ

Müşterilerimizin ihtiyaçlarını karşılayacak çözümleri bilgi teknolojilerini kullanarak en verimli ve kaliteli şekilde sunmaktır.

Polat Group Redüktör olarak birçok farklı ürün yelpazesi ile, müşteri ihtiyacını maksimum seviyede karşılamak için eş zamanlı mühendislik yöntemlerini kullanarak çalışmalarını sürdürmektedir. Tasarım faaliyetleri, ürün geliştirme programları ve bilgisayar destekli çalışmalarımız sürekli gelişen bir grafik çizmektedir. Rekabetçi ve güçlü kalite politikamız müşteri yelpazemizi genişletmektedir.

EN

OUR QUALITY POLICY

To achieve the best quality of its products, POLAT GROUP REDÜKTÖR A.Ş. adopts with its own quality politics by following the technological developments of its sector, in order to keep up the stabilization on its own market share ensuring the customers' gladness increasing permanently by answering the customers' wishes and expectations completely at the right time to have the well-educated staffs increase their performance by providing a peaceful working place and making better the quality management system all the time.

OUR VISION

Our vision is to become a world company which keeps the customer satisfaction at the top level and which does not only follow the developments but also creates the developments itself.

OUR MISSION

Our mission is to provide the solutions to our customers in most efficient and qualified way by make use of the information technologies.

Our reducer group carries out its works using simultaneous engineering methods in order to meet the demands of our customers by presenting several different product ranges. Promotion activities, product development programmes and computer supporting work show a continuously growing chart. Our competitive and strong quality policy is to develop our customer spectrum.

DE

UNSERE QUALITÄTSPOLITIK

Wir verfolgen ständig alle technologischen Entwicklungen in unserem Sektor, um die beste Qualität an den Produkten von POLAT GROUP REDÜKTÖR GmbH zu schaffen. Wir erfüllen und liefern die Anforderungen und Erwartungen unserer Kunden vollständig und pünktlich, um die Stabilität unseres Marktanteils zu halten, und eine ständig steigende Kundenzufriedenheit zu verwirklichen. Wir haben unsere Qualitätspolitik verinnerlicht und verbessern die Qualitätsverwaltungssysteme ständig in entsprechender Weise und versuchen dauernd, unsere Arbeitsumgebung noch gemüthlicher zu gestalten, um die Leistungsfähigkeit unserer erfahrenen Mitarbeiter und Mitarbeiterinnen ständig zu erhöhen.

UNSERE VISION

Unsere Vision ist ein Weltunternehmen zu erschaffen, das die Kunden- und Mitarbeiterzufriedenheit ständig im höchsten Zustand hält und die Entwicklungen nicht nur verfolgt, sondern auch gestaltet.

UNSER ZIEL

Unser Ziel ist unseren Kunden die Produkte, Qualitäts- und Dienstleistungen sowie Lösungen, die die Kundenerwartungen übertreffen und im besten und leistungsfähigsten Zustand mit Hilfe der neuesten Informationstechnologien zu bieten.

Polat Group Redüktör GmbH führt sämtliche Tätigkeiten des Ingenieurwesens gleichzeitig weiter, um die Kundenerwartungen an alle unsere Produkte aus verschiedenen Produktpaletten im höchsten Zustand zu übertreffen. Unsere Entwurfstätigkeiten und Produktentwicklungsprogramme und EDV unterstützten Arbeitsprozesse zeigen eine steigende Grafik. Unsere wettbewerbsfähige und kräftige Qualitätspolitik vergrößert unseren Kundenumfang weiter.

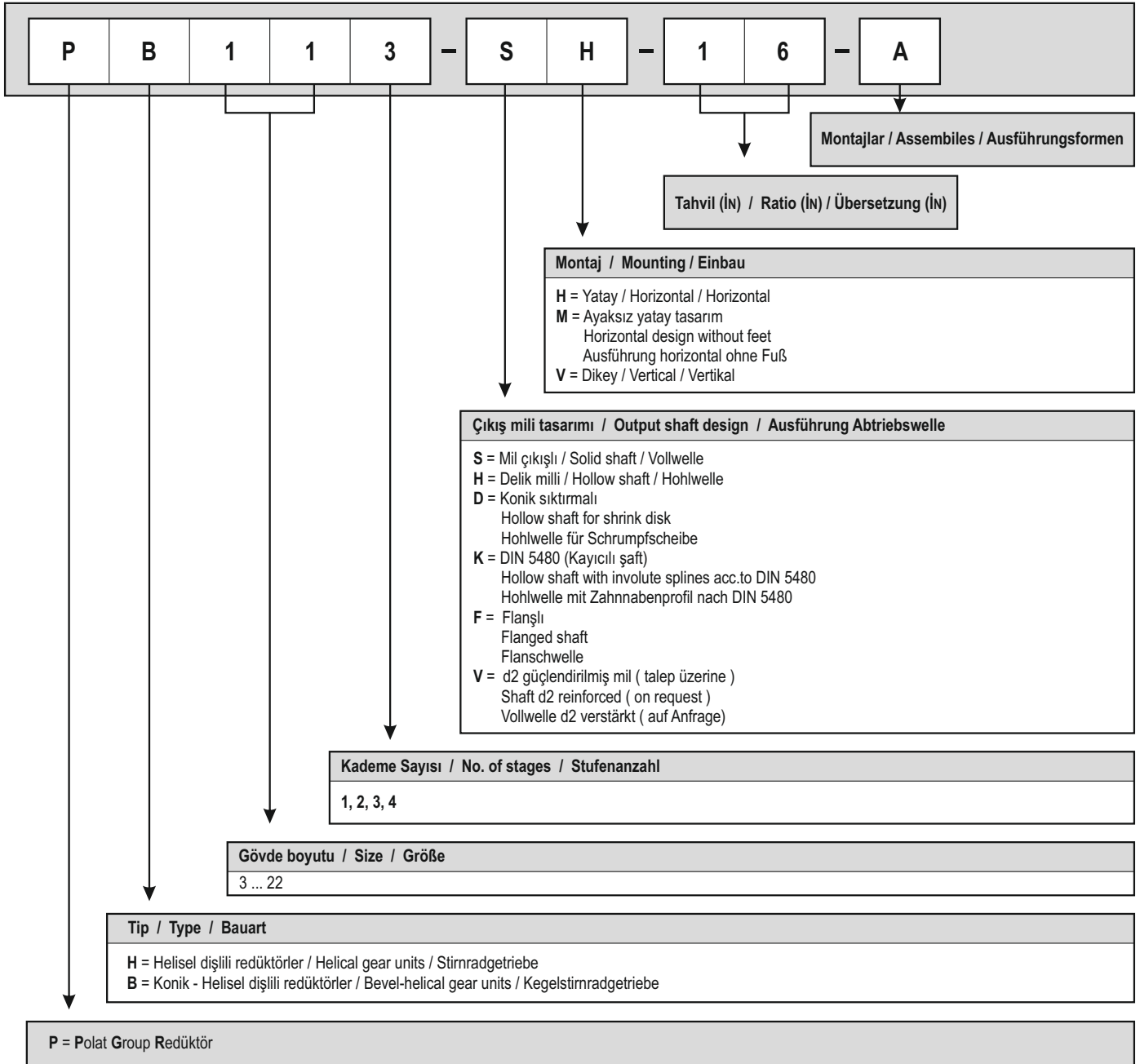

Sipariş için gerekli ayrıntılı bilgiler:  66 - 67
Aktarım oranı i , A, B, C, D, vb dizayn,

Further details required in orders:
Transmission ratio i, designs A, B, C, D, etc.

Weitere bei Bestellung notwendige Angaben:
Übersetzung i, Ausführungen A, B, C, D, usw.

Örnek PB113-SH
Helisel- konik dişli redüktör, boyut 11, 3 kademe, i= 16, dizayn A, çıkış mili tasarımı,
Yatay montaj pozisyonu,

Example PB113-SH
Bevel - helical gear unit, size 11, 3 stage, i= 16, design A, solid output shaft design,
Horizontal mounting position.

Beispiel PB113-SH
Kegelstirradgetriebe, Größe 11, 3- stufig, i= 16, Ausführung A, Abtrieb in Vollwellenausführung,
Horizontale Einbaulage.

Yatay montaj pozisyonu / Horizontal mounting position / Einbaulage horizontal

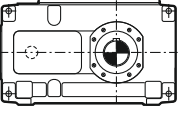
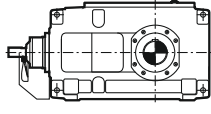
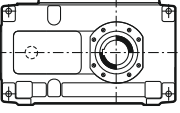
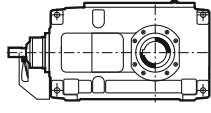
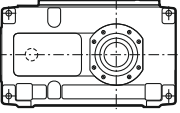
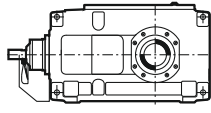
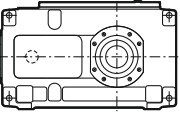
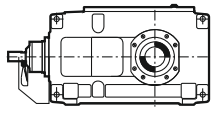
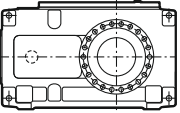
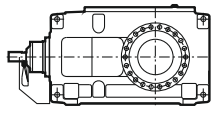
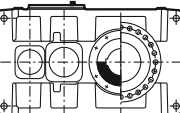
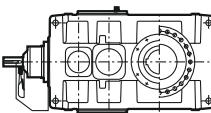
	PH...-SH	<p>Helisel dişli redüktörler Helical gear units Stirnradgetriebe</p> <p>Tip / Type / Bauart PH...1 PH...2 PH...3 PH...4</p> <p>1... 4 Kademe 1... 4 Stage 1... 4 Stufig iN = 1.25 - 450</p>		PB...-SH	<p>Helisel-Konik Dişli Redüktörler Bevel - Helical Gear Units Kegelstirnradgetriebe</p> <p>Tip / Type / Bauart PB...2 PB...3 PB...4</p> <p>2...4 Kademe 2...4 Stage 2...4 Stufig iN = 5 - 400</p>
	PH...-HH			PB...-HH	
	PH...-DH			PB...-DH	
	PH...-KH			PB...-KH	
	PH...-FH			PB...-FH	
	PH...-HM PH...-DM PH...-KM PH...-FM			PB...-HM PB...-DM PB...-KM PB...-FM	

Dikey montaj pozisyonu / Vertical mounting position / Einbaulage vertikal

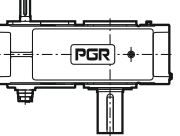
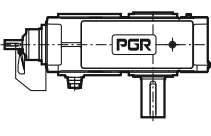
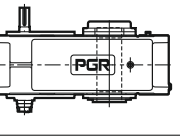
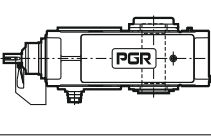
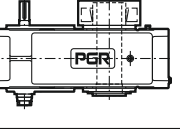
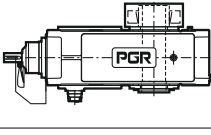
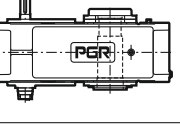
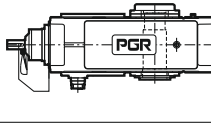
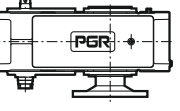
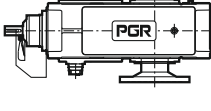
	PH...-SV	<p>Helisel dişli redüktörler Helical gear units Stirnradgetriebe</p> <p>Tip / Type / Bauart PH...2 PH...3 PH...4</p> <p>2...4 Kademe 2...4 Stage 2...4 Stufig iN = 6.3 - 450</p>		PB...-SV	<p>Helisel-Konik Dişli Redüktörler Bevel - Helical Gear Units Kegelstirnradgetriebe</p> <p>Tip / Type / Bauart PB...2 PB...3 PB...4</p> <p>2...4 Kademe 2...4 Stage 2...4 Stufig iN = 5 - 400</p>
	PH...-HV			PB...-HV	
	PH...-DV			PB...-DV	
	PH...-KV			PB...-KV	
	PH...-FV			PB...-FV	

TR KARAKTERİSTİK ÖZELLİKLER

İmalat

PGR dişli redüktörleri, tamamen yeniden dizayn edildi. Avantajları:

- Daha az parçayla, daha fazla gövde büyüklüğü,
- Artan güç kapasitesi ile daha yüksek işletme şartlarında güvenilirlik,
- Ağırlıklı olarak temassız, aşınmaya dayanıklı labirent keçelerde mevcuttur.
- Redüktör montajını kolaylaştıran ve daha az yer gerektiren flanşlı çıkış millerimiz de mevcuttur (Talep edildiğinde).

Montaj Şekilleri

PGR dişli redüktörleri, yatay veya dikey montajlı şekilde teslim edilmektedir.

Firmamızla görüşülerek, diğer düzenlemelerin uygulanması da ayrıca mümkündür.

Müşteri talebi üzerine, seçilen redüktörlere örneğin motor montaj adaptörü, tork kolu veya kilit v.b farklı donanımları eklenmesi mümkündür.

Gürültü Seviyesi

PGR dişli redüktörlerinde, gürültü seviyesi kesin ve kalıcı bir şekilde azaltılabilmektedir. İşbu kapsamda:

- Konik dişliler taşlanır,
- CNC bilgisayar programıyla, gürültü seviyesini azaltacak şekilde bir gövde ve
- Yüksek kalitede dişli sistemi geliştirilir.

Isı İletkenliği

PGR dişli redüktörlerinin avantajları, sadece gövdenin daha büyük olmasıyla sınırlı değildir, ayrıca

- Büyük yüzey alanı sayesinde;
- Temassız ve aşınmaz tipteki labirent keçesi donanımlarıyla ve
- Yeni bir ısı iletim şekli sağlayan fan kapaklı güçlendirilmiş büyük fanlarıyla,

Redüktör seçiminde PGR, gereken en düşük maksimum yağ sıcaklığını temel olarak alır. Bu sayede, işyeri güvenliği artar ve yağlama aralıklarının daha uzun olması nedeniyle, bakım masrafları da azalır.

Depolama

PGR dişli redüktörleri, yeni bir modüler sisteme göre tasarlandı. Bu sayede, farklı montaj parçalarının sayısı azaltıldı. İlgili montaj parçalarının oldukça büyük bölümü, stoklarımızda mevcuttur.

EN CHARACTERISTIC FEATURES

Design

PGR gear units are a completely new design. Advantages are:

- More sizes with a reduced variety of parts;
- Higher operational reliability combined with increased power capacity;
- Predominantly non-contacting wear-resistant labyrinth seals are possible;
- Flanged output shafts to facilitate assembly of gear units in confined spaces (on request).

Mounting position

PGR gear units can be supplied for either horizontal or vertical installation.

Other arrangements are also possible on request. The basic gear unit can be optimally adapted to customer requirements by fitting different add-on pieces like motor bell housings, gear unit swing-bases or backstops.

Noise behaviour

New concepts were applied to clearly improve the noise emission of the gear units by

- Grinding the bevel gears;
- Designing noise-absorbing housings by means of the CNC computing program; and
- Achieving exceptionally large contact ratios.

Thermal conduction

PGR-gear units not only have a high efficiency but also a favourable thermal conduction.

- Through enlarged housing surface areas;
- Because non-contacting labyrinth seals can be used; and
- Because large fans incorporating a new type of air conduction fan cowl are being used.

The selection of PGR gear units is based on a lower maximum oil temperature. By that the operational reliability will be increased and the cost of maintenance reduced due to longer oil change intervals.

Storing

PGR gear units have been designed according to a new unit construction principle. Through this, the variety of parts could be reduced.

DE CHARAKTERISTISCHE VORZÜGE

Konstruktion

PGR Zahnradgetriebe wurden völlig neukonzipiert. Pluspunkte sind:

- Mehr Baugrößen bei weniger Bauteilvarianten,
- Höhere Betriebssicherheit bei gesteigerter Leistungsdichte,
- Überwiegend berührungs- und verschleiß-freie Labyrinthdichtungen möglich,
- Flanschabtriebswellen zur leichteren Getriebemontage bei kleinem Raumbedarf (auf Anfrage).

Einbaulage

PGR - Zahnradgetriebe sind für horizontale und vertikale Einbaulage lieferbar.

Auch andere Anordnungen sind nach Rücksprache möglich. Das Grundgetriebe kann durch unterschiedliche Anbauteile wie z.B. Motorlaternen, Getriebschwingen oder Rücklaufsperrern optimal an die Kundenanforderungen angepasst werden.

Geräuschverhalten

Bei PGR - Zahnradgetrieben konnte das Geräuschverhalten entscheidend verbessert werden. Dazu wurden:

- Die Kegelräder geschliffen,
- Die geräuschdämpfenden Gehäuse mit CNC-Rechenprogramm entwickelt und
- Außergewöhnlich hohe Überdeckungsgrade der Verzahnung erreicht.

Temperaturverhalten

PGR - Zahnradgetriebe haben bei einem guten Wirkungsgrad ein günstiges Temperaturverhalten, weil

- Die Gehäuseoberflächen vergrößert wurden
- Überwiegend berührungsfreie Labyrinthdichtungen eingesetzt werden können und
- Große Lüfter mit einem neu entwickelten Luftleitsystem zur Anwendung kommen

Bei der Getriebeauswahl legt PGR eine niedrige maximale Öltemperatur zugrunde. Die Betriebssicherheit wird dadurch erhöht und der Wartungsaufwand verringert sich durch längere Ölstandszeiten.

Vorratshaltung

PGR - Zahnradgetriebe sind nach einem neuen Baukastensystem konstruiert. Dadurch konnte die Zahl der Bauteilvarianten reduziert werden.

TR





GENEL BİLGİLER

Dikkat!

Aşağıda belirtilen unsurlara mutlaka dikkat edilmelidir!

- Burada yer alan resim ve çizimler sadece örnek olarak gösterilmiştir ve bağlayıcı değildir. Firmamızın ölçüleri değiştirme hakkı saklıdır.
- Belirtilen ağırlıklar, ortalama değerlerdir ve bağlayıcı değildir.
- Hareketli parçalara kazayla temas edilmemesi için, alıcı tarafından gereken tedbirler alınmalıdır. İlgili ülkede geçerli ve yürürlükte olan güvenlik yönetmeliklerine, mutlaka dikkat edilmelidir.
- Kullanmaya başlamadan önce, kullanma ve çalıştırma kılavuzu mutlaka incelenmelidir. Redüktörler, kullanıma hazır, ancak yağ doldurulmadan teslim edilir.
- Burada belirtilen yağ miktarları, sadece önerilen değerlerdir ve bağlayıcı değildir. İşbu kapsamda, yağ ölçme çubuğuyla tespit edilen yağ seviyesi belirleyicidir.
- Yağ viskozitesi, mutlaka etikette belirtilen değere uygun olmalıdır.
- Sadece onaylanan yağ tipleri kullanılmalıdır. En güncel kullanma kılavuzu ve yağ tipi tabloları, web sitemizde yer almaktadır: www.pgr.com.tr
- Redüktörler, döner mil keçeleri takılı durumda teslim edilir. Diğer sızdırmazlık yöntemleri, sipariş üzerine uygulanır.
- Dönme yönü bilgileri, d₂ çıkış miline bağlıdır.
- Redüktörün açık bir alanda monte edilmesi durumunda, güneş ışınlarından korunmalıdır. İlgili önlem ve tedbirlerin alınması, müşterinin sorumluluğundadır.

Ölçülü çizimlerdeki sembollerin açıklamaları:

-  = Yağ ölçme çubuğu
-  = Havalandırma
-  = Yağ boşaltma Tapası
-  = Yağ doldurma Tapası

EN



GENERAL INFORMATION

Attention!

The following items are absolutely to be observed!

- Illustrations are examples only and are not strictly binding. Dimensions are subject to change.
- The weights are mean values and not strictly binding.
- To prevent accidents, all rotating parts should be guarded according to local and national safety regulations.
- Prior to commissioning, the operating instructions must be observed. The gear units are delivered ready for operation but without oil filling.
- Oil quantities given are guide values only. The exact quantity of oil depends on the marks on the oil dipstick.
- The oil viscosity has to correspond to the data given on the name plate.
- Approved lubricants may be used only. You will find current operating instructions and lubricant selection tables on our home page at: www.pgr.com.tr
- The gear units are supplied with radial shaft seals. Other sealing variants on request.
- Directions of rotation referring to output shaft d₂.
- In case of outdoor installation, insolation is to be avoided. The customer has to provide adequate protection.

Explanation of symbols used in the dimensioned drawings.

-  = Oil dipstick
-  = Breather
-  = Oil drain
-  = Oil filler

DE





ALLGEMEINE HINWEISE

Achtung!

Folgende Punkte sind unbedingt zu beachten!

- Abbildungen sind beispielhaft und nicht verbindlich. Maßänderungen bleiben vorbehalten.
- Die angegebenen Gewichte sind unverbindliche Mittelwerte.
- Umlaufende Teile müssen vom Käufer gegen unbeabsichtigtes Berühren geschützt werden. Die gültigen Sicherheitsbestimmungen des jeweiligen Einsatzlandes sind zu beachten.
- Vor Inbetriebnahme ist die Betriebsanleitung zu beachten. Die Getriebe werden betriebsfertig, jedoch ohne Ölfüllung geliefert.
- Ölmengenangaben sind unverbindliche Richtwerte. Maßgebend ist die Ölstandsmarkierung am Ölmesstab.
- Ölviskosität muss den Angaben des Typenschildes entsprechen.
- Es dürfen nur freigegebene Schmierstoffe verwendet werden. Aktuelle Betriebsanleitungen und Schmierstofftabellen finden Sie auf unserer Homepage unter: www.pgr.com.tr
- Die Getriebe werden mit Radialwellendichtringen ausgeliefert. Andere Dichtungsvarianten auf Anfrage.
- Drehrichtungsangaben beziehen sich auf die Abtriebswelle d₂.
- Bei Aufstellung im Freien ist Sonnenbestrahlung zu vermeiden. Entsprechende Schutzeinrichtungen sind kundenseitig vorzusehen.

Erklärung der Symbole in den Maßzeichnungen:

-  = Ölmesstab
-  = Entlüftung
-  = Ölablass
-  = Öleinfüllung

Gövde büyüklüğü 13... ve üzeri olan redüktörlerde basınç vidaları, gövde ayağında ve gövdenin üst kısmındaki ayar yüzeylerinde yer alır.

Gövde üzerinde bulunan sabitleme deliklerine vidalanması gereken taban civatalarının mukavemet sınıfı en az 8.8'dir. DIN EN 20273'e göre.

Redüktörlerin korozyona karşı korunması sağlanmış ve RAL 7000 renk tonunda boyanmıştır.

From size 13... up jack screws in the housing feet and leveling pads on the upper housing part.

Foundation bolts of min. property class 8.8. Tolerance of the clearance holes in the housing acc. to DIN EN 20273- "coarse" series.

The gear housings are protected against corrosion and sprayed in RAL 7000.

Ab Getriebegröße 13... Druckschrauben im Gehäusefuß und Ausrichtflächen auf dem Oberteil des Gehäuses.

Fußschrauben mit Mindest-Festigkeitsklasse 8.8. Toleranz der Befestigungsbohrungen im Gehäuse nach DIN EN 20273 - Reihe "grob".

Die Getriebe sind konserviert und im Farbton RAL 7000 lackiert.

DIN EN ISO 9001'e göre

Certified acc.to DIN EN ISO 9001

Zertifiziert nach DIN EN ISO 9001

<p>1. Redüktörün Tipi ve Boyutunun Belirlenmesi Determination of gear unit type and size Bestimmung von Getriebebauart und Größe</p>	<p>1.1 Tahvil oranının belirlenmesi Find the trasmission ratio Bestimmung der Übersetzung</p> $is = \frac{n1}{n2}$ <p>1.2 Redüktör nominal gücünü belirleme Determine nominal power rating of the gear unit Bestimmung der Getriebennleistung</p> $P2N \geq P2 \times f1 \times f2$ <p>Aşağıdakileri belirleyebiliyorsanız, şirketimize danışmanıza gerek yoktur. It is not necessary to consult us, if, Rücksprache nicht erforderlich, wenn.</p> $3.33 \times P2 \geq P2N$ <p>1.3 Örneğin, redüktörün en yüksek çalışma momenti, başlangıç momenti ve frenleme momenti benzeri, maksimum momentlerinin kontrol edilmesi, Check for maximum torque, e.g. peak operating-, starting- or braking torque Kontrolle auf Maximalmoment z.B.; Betriebsspitzen-, Anfahr- oder Bremsmoment</p> $P2N \geq \frac{Ta \times n1}{9550} \times f3$ <p>İN ve P2N'e göre redüktör boyutları ve Kademe sayıları tabloda verilmiştir. Gear unit sizes and number of reduction stages are given in rating tables depending on iN and P2N Getriebegrößen und Stufenanzahl sind in den Leistungstabellen abhängig von iN und P2N festgelegt</p> <p>1.4 Çıkış milinin maruz kalacağı ilave yüklerin kontrol edilmesi için, lütfen 60 ve 61. sayfalara bakın. Check whether additional forces on the output shaft are permissible; see pages 60 and 61 Prüfung der Zulässigkeit von Zusatzkräften auf die Abtriebswelle; siehe Seiten 60 und 61</p> <p>1.5 Öngörülen i tahvil değerinin, uygun olup olmadığının kontrol edilmesi için, lütfen 56 ile 59 arası sayfalara bakın. Check whether the actual ratio i as per tables on pages 56 - 59 is acceptable Prüfung, ob Ist-Übersetzung i geeignet ist, siehe Seiten 56 - 59</p>		
Montaj pozisyonu / Mounting position / Einbaulage			
	<table border="1" style="width: 100%;"> <tr> <td style="text-align: center;">Yatay / Horizontal / Horizontal</td> <td style="text-align: center;">Dikey / Vertical / Vertikal</td> </tr> </table>	Yatay / Horizontal / Horizontal	Dikey / Vertical / Vertikal
Yatay / Horizontal / Horizontal	Dikey / Vertical / Vertikal		
<p>2. Kullanılacak Yağ Tipinin Belirlenmesi Determination of oil supply Bestimmung der Ölversorgung</p>	<p>Yağlanması gereken tüm parçalar, yağ içerisine konularak veya benzer şekilde, sıçramalı yağlama uygulanarak yağlanır. Basınçlı yağlama, ancak istek ve sipariş üzerine temin edilir.</p> <p>All parts to be lubricated are lying in the oil or are splash lubricated Forced lubrication on request</p> <p>Alle zu schmierenden Elemente liegen im Öl bzw. werden mit Spritzöl versorgt Druckschmierung auf Anfrage</p> <p>Yağlama Tipleri:</p> <ul style="list-style-type: none"> • Yağ içerisine daldırma yöntemiyle yağlama. • Flanş pompası ve motor pompası yardımıyla, basınçlı yağlama. <p>Tercih edilen uygulama yöntemleri ve seçme kriterleri için, lütfen 137 ile 158 arası sayfalara bakın.</p> <p>Possible oil supply variations:</p> <ul style="list-style-type: none"> • Dip lubrication • Forced lubrication by means of flanged-on pump or motor pump <p>For preferred variants and criteria for selection, see pages 137 - 158</p> <p>Mögliche Ölversorgungsvarianten:</p> <ul style="list-style-type: none"> • Tauchschmierung • Druckschmierung mittels Flansch- oder Motorpumpe <p>Vorzugsvarianten und Auswahlkriterien siehe Seiten 137 - 158</p>		

TR TERMAL KAPASİTE SEÇİMİ İÇİN KURALLAR

3. Gerekli Termal Kapasite Belirlenmesi Pt

Gereken Veriler:

- Tip, Boyut, Nominal tahvil
- Ortam sıcaklığı
- Giriş devir hızı (1000 / 1200 / 1500 / 1800 d/d)
- Daldırma yöntemiyle yağlamalı redüktör

Müteakip Hesaplamalarda, Aşağıda Belirtilenler Geçerlidir:

- Çalışma döngüsü: 100%
- Büyük bir alanda kurulduğunda (rüzgar hızı >= .4 m/s), Rakım 1000 m'ye kadar
- ISO-VG460 tipi mineral yağı redüktörler

EN GUIDELINES FOR THE SELECTION THERMAL CAPACITIES

3. Determination of required thermal capacity Pt. Data required:

- Type, Size, Nominal ratio
- Ambient temperature
- Input speed (1000 / 1200 / 1500 / 1800 min⁻¹)
- Gear unit with dip lubrication

For the calculation below the following has been assumed:

- Operating cycle: 100 %
- Installation in a large hall (wind velocity >= 1.4 m/s),
- Altitude up to 1000 m
- Gear unit with mineral oil ISO-VG460

DE RICHTLINIEN FÜR DIE AUSWAHL KONSTANTE LEISTUNG THERMISCH

3. Bestimmung der erforderlichen Wärmegrenzleistungen Pt Notwendige Daten:

- Bauart ,Größe, Nennübersetzung
- Umgebungstemperatur
- Antriebsdrehzahl (1000 / 1200 / 1500 / 1800 min⁻¹)
- Getriebe mit Tauchschnürung

Für die nachfolgende Rechnung gelten folgende Annahmen:

- Einschaltdauer: 100%
- Aufstellung in großer Halle(Windgeschwindigkeit>=1.4 m/s),
- Höhenlage bis 1000 m
- Getriebe mit Mineralöl ISO-VG460

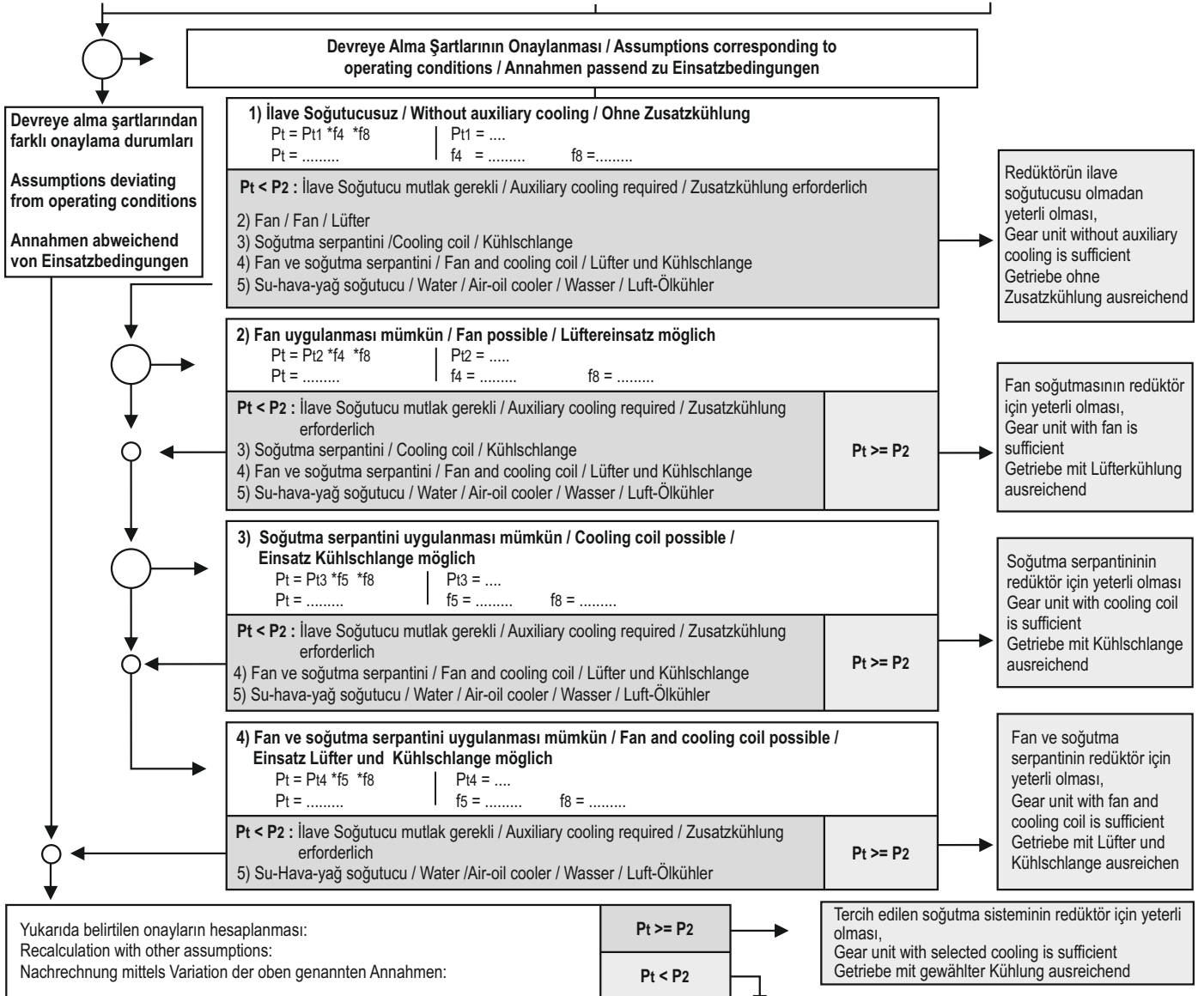

Mutlaka PGR ile görüşülmelidir!

- Aşağıda belirtilenlere değişiklikler konusunda mutlaka PGR ile görüşülmelidir:
- Yağ cinsi / Yağ viskozitesi / Yağ seviyesi
 - Ana Redüktör veya şaft montajlı redüktör
 - Yağ soğutucusu ekleme

Consult PGR!

- Variation of the following items is possible:
- Oil grade / Viscosity / level
 - Gear unit on foundation or shaft-mounted gear unit
 - Application of an oil supply system

Rücksprache mit PGR notwendig!

- Variationsmöglichkeiten für folgende Daten:
- Ölsorte / Ölviskosität / Ölstand
 - Fundament - oder Aufsteckgetriebe
 - Einsatz einer Ölkühlanlage

***) Bu değerler, Soğuk Su Giriş Isısının 20°C olması şartıyla geçerlidir.**

***) Values refer to a cooling water inlet temperature of 20°C.**

***) Werte gelten für eine Kühlwassereintritts temperatur von 20°C.**

Gerek olması halinde, ilave edilecek ekstra soğutucu tipinin belirlenmesi, müşterinin işletmesindeki mevcut şartlara bağlıdır (Toz / kir durumu, soğuk su bağlantısının mevcut olup olmadığı ve benzeri şartlara bağlıdır)

The type of the possibly required additional cooling is dependent on the operating conditions at the customer's (dust, cooling water connection, etc.)

Die Art der gegebenenfalls notwendigen Zusatzkühlung ist von den Einsatzbedingungen beim Kunden (Staubbelastung, Kühlwasseranschluß usw.) abhängig.

TR DEĞİŞKEN GÜÇ SEÇİMİ İÇİN KURALLAR

Devir sayısı sabit ve gücü değişken iş makineleri için redüktör tespiti, güç denkliğine göre belirlenebilir.

Bu kapsamda, I, II...n fazları için sırasıyla $P_I, P_{II}...P_n$ güçlerini gerektiren iş döngüsü, temel olarak alınır ve burada, ilgili güçlerin her birinin sırasıyla $X_I, X_{II}...X_n$ şeklinde yüzdelik süre dilimleri vardır.

Bu verilerle, eşdeğer güç aşağıda belirtilen formüle göre hesaplanır:

$$P_{2\dot{a}q} = \sqrt[6.6]{P_I^{6.6} \times \frac{X_I}{100} + P_{II}^{6.6} \times \frac{X_{II}}{100} + \dots + P_n^{6.6} \times \frac{X_n}{100}}$$

Ardından redüktör büyüklüğünün belirlenmesi, 1.1'den 1.5'e kadar ve 3 numaralı maddelerde belirtildiği üzere, yapılır. Bu kapsamda, aşağıda belirtilenler geçerlidir:

$$P_{2N} \geq P_{2\dot{a}q} \times f_1 \times f_2$$

P_{2N} değerinin tespit edildikten sonra, güç ve süre dilimi değerleri, aşağıda belirtilen şartlara göre kontrol edilir.

- 1) $P_I, P_{II}...P_n$ güç değerlerinin her birinin, $0.4 \times P_{2N}$ değerinden daha büyük olması gerekir.
- 2) $P_I, P_{II}...P_n$ güç değerlerinin hiçbirisi, $1.4 \times P_{2N}$ değerini aşmamalıdır.
- 3) P_{2N} değerinden daha büyük olan $P_I, P_{II}...P_n$ güç değerlerinde, $X_I, X_{II}...X_n$ süre dilimlerinin toplamı en fazla %10 olmalıdır.

Bu üç şarttan herhangi birinin sağlanamaması durumunda, $P_{2\dot{a}q}$ değeri yeniden hesaplanır.

Bu kapsamda, $P_{2\dot{a}q}$ değerinin tespit edilmesinde, dikkate alınmayan kısa süreli ani bir güç artışı değerinin, asla $P_{max} = 2 \times P_{2N}$ değerinden yüksek olamayacağına, dikkat edilmelidir.

Dönme momentleri değişken, ancak devir sayısı sabit olan işlerde, redüktör seçimi eşdeğer belirli uygulamalarda, sadece kullanma ömrü redüktör seçimi için yeterlidir.

Bu kapsama, örneğin düzensiz çalışma veya düşük çıkış devir sayıları dahildir. ($n_2 < 4 \text{ d/d}$)

EN GUIDELINES FOR THE SELECTION VARIABLE POWER RATING

For driven machines with constant speeds and variable power ratings the gear unit can be designed according to the equivalent power rating. For this, a working cycle where phases I, II...n require power $P_I, P_{II}...P_n$ and the respective power ratings operate for time fractions $X_I, X_{II}...X_n$ is taken as a basis.

The equivalent power rating can be calculated from these specifications with the following formula:

$$P_{2\dot{a}q} = \sqrt[6.6]{P_I^{6.6} \times \frac{X_I}{100} + P_{II}^{6.6} \times \frac{X_{II}}{100} + \dots + P_n^{6.6} \times \frac{X_n}{100}}$$

The size of the gear unit can then be determined analogously to points 1.1...1.5 and 3. as follows:

$$P_{2N} \geq P_{2\dot{a}q} \times f_1 \times f_2$$

Then, when P_{2N} has been determined, the power and time fractions must be checked by applying the following requirements:

- 1) The individual power fractions $P_I, P_{II}...P_n$ must be greater than $0.4 \times P_{2N}$.
- 2) The individual power fractions $P_I, P_{II}...P_n$ must not exceed $1.4 \times P_{2N}$.
- 3) If power fractions $P_I, P_{II}...P_n$ are greater than P_{2N} , the sum of time fractions $X_I, X_{II}...X_n$ must not exceed 10%.

If any one of the three requirements is not met, $P_{2\dot{a}q}$ must be recalculated.

It must be borne in mind that a brief peak power rating not included in the calculation of $P_{2\dot{a}q}$ must not be greater than $P_{max} = 2 \times P_{2N}$.

In applications where the **torque is variable** but the **speed constant** the gear unit can be designed on the basis of the so-called equivalent torque.

A gear unit design which is **finite-life fatigue-resistant** can be sufficient for certain applications, for example, sporadic operation (lock-gate drives) or low output speeds. ($n_2 < 4 \text{ min}^{-1}$)

DE RICHTLINIEN FÜR DIE AUSWAHL VARIABLE LEISTUNG

Für Arbeitsmaschinen mit konstanten Drehzahlen und variablen Leistungen kann das Getriebe nach der sogenannten äquivalenten Leistung ausgelegt werden.

Dabei wird ein Arbeitszyklus zugrunde gelegt, dessen Phasen I, II...n die Leistungen $P_I, P_{II}...P_n$ erfordern, wobei die jeweiligen Leistungen den prozentualen Zeitanteil $X_I, X_{II}...X_n$ haben. Mit diesen Angaben wird die äquivalente Leistung nach folgender Formel berechnet:

$$P_{2\dot{a}q} = \sqrt[6.6]{P_I^{6.6} \times \frac{X_I}{100} + P_{II}^{6.6} \times \frac{X_{II}}{100} + \dots + P_n^{6.6} \times \frac{X_n}{100}}$$

Die Bestimmung der Getriebegröße erfolgt dann analog den Punkten 1.1...1.5 und 3. Dabei gilt:

$$P_{2N} \geq P_{2\dot{a}q} \times f_1 \times f_2$$

Anschließend, nachdem P_{2N} bestimmt wurde, sind die Leistungs- und Zeitanteile nach folgenden Bedingungen zu prüfen.

- 1) Die einzelnen Leistungsanteile $P_I, P_{II}...P_n$ müssen größer $0.4 \times P_{2N}$ sein.
- 2) Die einzelnen Leistungsanteile $P_I, P_{II}...P_n$ dürfen $1.4 \times P_{2N}$ nicht überschreiten.
- 3) Bei den Leistungsanteilen $P_I, P_{II}...P_n$, die größer als P_{2N} sind, darf die Summe der Zeitanteile $X_I, X_{II}...X_n$ maximal 10% betragen.

Falls eine der drei Bedingungen nicht erfüllt wird, so ist eine erneute Berechnung von $P_{2\dot{a}q}$ notwendig.

Grundsätzlich ist zu berücksichtigen, dass eine kurzzeitige Spitzenleistung, die nicht bei der Ermittlung von $P_{2\dot{a}q}$ erfasst wird, nicht größer als $P_{max} = 2 \times P_{2N}$ sein darf.

In Einsatzfällen mit **variablen Drehmomenten** aber **konstanter Drehzahl** erfolgt die Getriebeauslegung auf der Basis des sogenannten **äquivalenten Drehmomentes**.

Für bestimmte Anwendungen kann eine **zeitfeste Auslegung** des Getriebes ausreichend sein. Dazu gehören zum Beispiel sporadischer Einsatz (Schleusenantriebe) oder geringe Abtriebsdrehzahlen. ($n_2 < 4 \text{ min}^{-1}$)

Örnek:
Ortak çalışma
Example:
Service classification
Beispiel:
Lastkollektiv

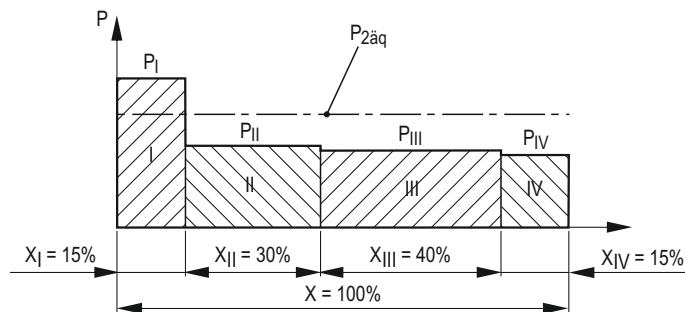

TR REDÜKTÖR SEÇİMİNDE MEKANİK GÜÇ DEĞERİ HESAPLANMASI İÇİN KURALLAR

Verilenler:

GÜÇ KAYNAĞI

Elektrik motoru: P1 = 30 kW
Motor devir sayısı: n1 = 1500 d/d
Max. hareket momenti: TA = 300 Nm

İŞ MAKİNELERİ

Bantlı konveyör: P2 = 22 kW
Devir sayısı: n2 = 35 d/d
Çalışma süresi: 8 h / gün

Saatlik çalışma sayısı: 10
Saat başı çalışma süresi: ED = 100%
Ortam sıcaklığı: 30 °C
Büyük alanda kurulum: Rüzgar hızı >=1.4 m/s
Rakım durumu: Deniz seviyesi

REDÜKTÖR TASARIMI:

Helisel-Konik dişli redüktör: Yatay
Montaj pozisyonu: Sağ,uygulama
d2 Çıkış mili : tasarım C, milli
d2 Çıkış milinin dönüş yönü: Sol

Gereken:

Redüktör tipi ve boyutu

1) Redüktör tipi ve boyutunun seçimi

1.1 Tahvil oranının hesaplanması

$$i_s = \frac{n_1}{n_2} = \frac{1500}{35} = 42.9 \quad i_N = 45$$

1.2 Redüktör nominal güç değerinin belirlenmesi

$$P_{2N} \geq P_2 \times f_1 \times f_2 = 22 \times 1.3 \times 1 = 28.6 \text{ kW}$$

PB53...SH tipi redüktör, P2N = 41 kW ile: güç oranı tablodan seçilebilir

Selected from power rating table: type PB53...SH with P2N = 41 kW

Aus Leistungstabelle Bauart PB53...SH, mit P2N = 41 kW gewählt.

$$3.33 \times P_2 \geq P_{2N} \quad 3.33 \times 22 = 73.3 \text{ kW} > P_{2N}$$

Bize danışmaya gerek yok
It is not necessary to consult us
Rücksprache nicht erforderlich

1.3 Başlangıç momenti kontrolü

1.3 Checking the starting torque

1.3 Kontrolle auf Anfahrmoment

$$P_{2N} \geq \frac{T_A \times n_1}{9550} \times f_3 = \frac{300 \times 1500}{9550} \times 0.65 = 30.6 \text{ kW} \quad P_{2N} = 41 \text{ kW} > 30.6 \text{ kW}$$

2. Yağlama Şeklinin Belirlenmesi

Daldırma yöntemiyle yağlamalı redüktörler

2. Determination of oil supply

Gear unit with dip lubrication

2. Bestimmung der Ölversorgung

Getriebe mit Tauchschiemung

EN GUIDELINES FOR THE SELECTION CALCULATION MECHANICAL POWER RATING

Know criteria:

PRIME MOVER

Electric motor: P1 = 30 kW
Motor speed: n1 = 1500 min⁻¹
Max. starting torque: TA = 300 Nm

DRIVEN MACHINE

Belt conveyor: P2 = 22 kW
Speed: n2 = 35 min⁻¹
Duty: 8 h / day

Stars per hour: 10
Operating cycle per hour: ED = 100%
Ambient temperature: 30 °C
Installation in large hall: wind velocity >=1.4 m/s
Altitude: sea level

GEAR UNIT DESIGN

Bevel-helical gear unit: Horizontal
Mounting position: on right hand side
Output shaft d2: design C, solid shaft
Direction of rotation of output shaft d2 : ccw

Required:

Type and size of gear unit

1. Selection of gear unit type and size

1.1 Calculation of transmission ratio

DE RICHTLINIEN FÜR DIE AUSWAHL BERECHNUNGSBEISPIEL MECHANISCH

Gegeben:

ANTRIEBSMASCHINE

Elektromotor: P1 = 30 kW
Motordrehzahl: n1 = 1500 min⁻¹
Max. Anfahrmoment: TA = 300 Nm

ARBEITSMASCHINE

Gurtbandförderer: P2 = 22 kW
Drehzahl: n2 = 35 min⁻¹
Betriebsdauer: 8 h / Tag

Anläufe je Stunde: 10
Einschaltdauer je Stunde: ED = 100%
Umgebungstemperatur: 30 °C
Aufstellung in großer Halle: windgeschwindigkeit >=1.4m/s
Höhenlage: Meereshöhe

GETRIEBEAUSFÜHRUNG

Kegelstrinradgetriebe Einbau: Horizontal
Abtriebswelle d2: rechts, Ausführung C, Vollwelle
Drehrichtung der Abtriebswelle d2: links

Gesucht:

Getriebebauart, Getriebegröße

1. Bestimmung der Getriebebauart und Größe

1.1 Bestimmung der Übersetzung

1.2 Bestimmung der Getriebeleistung

TR	SEMBOLLER	EN	KEY TO SYMBOLS	DE	ERKLÄRUNG DER BEZEICHNUNGEN
ED	= Saatte Çalışma döngüsü %, e.g. ED= 80% / h	ED	= Operating cycle per hour in %, e.g. ED = 80% / h	ED	= Einschaltdauer in % (z.B. ED = 80% je Stunde)
f1	= İş makineleri faktörü (Tablo 1). sayfa 14-15	f1	= Factor for driven machine (table 1). page 14-15	f1	= Arbeitsmaschinenfaktor (Tabelle 1), Seite 14-15
f2	= Harekete geçirme (tahrik) makineleri faktörü (tablo 2). sayfa 16	f2	= Factor for prime mover (table 2). page 16	f2	= Antriebsmaschinenfaktor (Tabelle 2), Seite 16
f3	= Ani yüksek tork faktörü (Tablo 3). sayfa 16	f3	= Peak torque factor (table 3). page 16	f3	= Spitzenmomentfaktor (Tabelle 3), Seite 16
f4	= Termal faktörler (Tablo 4). sayfa 16	f4	= Thermal factors (table 4). page 16	f4	= Wärmefaktoren (Tabelle 4), Seite 16
f5	= Termal faktörler (Tablo 5). sayfa 16	f5	= Thermal factors (table 5). page 16	f5	= Wärmefaktoren (Tabelle 5), Seite 16
f8	= Dikey redüktörlerde yağlama faktörü (Tablo 8), sayfa 16 Yatay redüktörlerde: f8 = 1	f8	= Oil supply factor for vertical gear units (table 8), page 16 For horizontal gear units: f8 = 1	f8	= Ölversorgungsfaktor bei Vertikalgetrieben, (Tabelle 8), Seite 16. Bei Horizontalgetrieben: f8=1
i	= Gerçek tahvil	i	= Actual ratio	i	= Ist-Übersetzung
iN	= Nominal tahvil	iN	= Nominal ratio	iN	= Nennübersetzung
is	= Gereken tahvil	is	= Required ratio	is	= Soll-Übersetzung
n1	= Giriş devir sayısı (d/d)	n1	= Input speed (min ⁻¹)	n1	= Antriebsdrehzahl (min ⁻¹)
n2	= Çıkış devir sayısı (d/d)	n2	= Output speed (min ⁻¹)	n2	= Abtriebsdrehzahl (min ⁻¹)
Pt	= Gereken termal kapasite	Pt	= Required thermal capacity	Pt	= Erforderliche Wärmegrenzleistung
Pt1	= İlave soğutucusu olmayan redüktörlerde termal kapasite sayfa 20-55 bakınız	Pt1	= Thermal capacity for gear units without auxiliary cooling, pages 20-55	Pt1	= Wärmegrenzleistung für Getriebe ohne Zusatzkühlung, Seiten 20-55
Pt2	= Fan soğutmalı redüktörlerde termal kapasite Sayfa 20-55 bakınız	Pt2	= Thermal capacity for gear units with fan cooling. pages 20-55	Pt2	= Wärmegrenzleistung für Getriebe mit Lüfterkühlung, Seiten 20-55
Pt3	= Monte edilmiş soğutma serpantinli redüktörlerde termal kapasite sayfa 20-55 bakınız	Pt3	= Thermal capacity for gear units with built-in cooling coil, pages 20-55	Pt3	= Wärmegrenzleistung für Getriebe mit eingebauter Kühlschlange, Seiten 20-55
Pt4	= Fanlı ve monte edilmiş soğutma serpantinli redüktörlerde termal kapasite sayfa 20-55 bakınız	Pt4	= Thermal capacity for gear units with built-in cooling coil and fan, pages 20-55	Pt4	= Wärmegrenzleistung für Getriebe mit eingebauter Kühlschlange und Lüfter, Seiten 20-55
P2N	= Redüktör nominal gücü (kW) değer tablolarına bakın. sayfa 18-55 bakınız	P2N	= Nominal power rating of gear unit (kW) see rating tables. pages 18-55	P2N	= Getriebennennleistung (Kw), siehe Leistungstabellen Seiten 18-55
P2	= Sürücü makinenin güç oranı (kW)	P2	= Power rating of driven machine (kW)	P2	= Leistung der Arbeitsmaschine (kW)
t	= Ortam sıcaklığı(°C)	t	= Ambient temperature (°C)	t	= Umgebungstemperatur (°C)
TA	= Ömeğin, redüktörün en yüksek çalışma momenti, hareket momenti ve frenleme momenti (Nm) benzeri giriş milinde ortaya çıkan max.dönme momenti	TA	= Max. torque occurring on input shaft, e.g. peak operating-, starting or braking torque (Nm)	TA	= Max. auftretendes Drehmoment an Eingangswelle z.B.: Betriebsspitzen-, Anfahr- oder Bremsmoment (Nm)
T2N	= Nominal çıkış momenti (kNm), sayfa 19-53 bakınız	T2N	= Nominal output torque (kNm), pages 19-53	T2N	= Nenn-Abtriebsdrehmoment (kNm), Seiten 19-53
P2äq	= Eşdeğer güç oranı (kW)	P2äq	= Equivalent power rating (kW)	P2äq	= äquivalente Leistung (kW)
P _I , P _{II} , P _n	= Ortak çalışma randımanı payları (kW)	P _I , P _{II} , P _n	= Fractions of power rating (kW) obtained from service classification	P _I , P _{II} , P _n	= Leistungsanteile (kW) aus Lastkollektiv
X _I , X _{II} , X _n	= Ortak çalışma süresi içerisindeki paylar (%)	X _I , X _{II} , X _n	= Fractions of time (%) obtained from service classification	X _I , X _{II} , X _n	= Zeitanteile (%) aus Lastkollektiv

TR

**TERMAL KAPASİTE SEÇİMİ İÇİN
HESAPLAMA ÖRNEĞİ**

EN

**GUIDELINES FOR THE SELECTION
CALCULATION
EXAMPLE THERMAL CAPACITY**

DE

**RICHTLINIEN FÜR DIE AUSWAHL
BERECHNUNGSBEISPIEL MECHANISCH**

3. Gerekli Termal Kapasite Belirlenmesi Pt

Gerekli Veri:

- Tip: PB53-SH
- Nominal tahvil: $i_N = 45$
- Ortam sıcaklığı: $t = 30^\circ\text{C}$
- Giriş devir sayısı: $n_1 = 1500 \text{ d/d}$
- Daldırma Yağlamalı Redüktör

Hesaplama için Aşağıda Belirtilen Onaylar Gereklidir:

- Çalışma döngüsü 100 %
- Büyük bir alanda kurulduysa (rüzgar hızı $> 1.4 \text{ m/s}$), Rakım 1000 m'ye kadar
- ISO VG460 Tipi Mineral Yağlı Redüktörler

3. Determination of required thermal capacity Pt

Data required:

- Type: PB53-SH
- Nominal ratio: $i_N = 45$
- Ambient temperature: $t = 30^\circ\text{C}$
- Input speed: $n_1 = 1500 \text{ min}^{-1}$
- Gear unit with dip lubrication

For the calculation below the following has been assumed:

- Operating cycle: 100 %
- Installation in a large hall (wind velocity $> 1.4 \text{ m/s}$), altitude up to 1000m
- Gear unit with mineral oil ISO-VG460

**3. Bestimmung der erforderlichen
Wärmegrenzleistungen Pt**

Notwendige Daten:

- Bauart: PB53-SH
- Nennübersetzung: $i_N = 45$
- Umgebungstemperatur: $t = 30^\circ\text{C}$
- Antriebsdrehzahl: $n_1 = 1500 \text{ min}^{-1}$
- Getriebe mit Tauchschnierung

Für die nachfolgende Rechnung gelten folgende Annahmen:

- Einschaltdauer: 100 %
- Aufstellung in großer Halle (Windgeschwindigkeit $> 1.4 \text{ m/s}$), Höhenlage bis 1000m
- Getriebe mit Mineralöl ISO-VG460

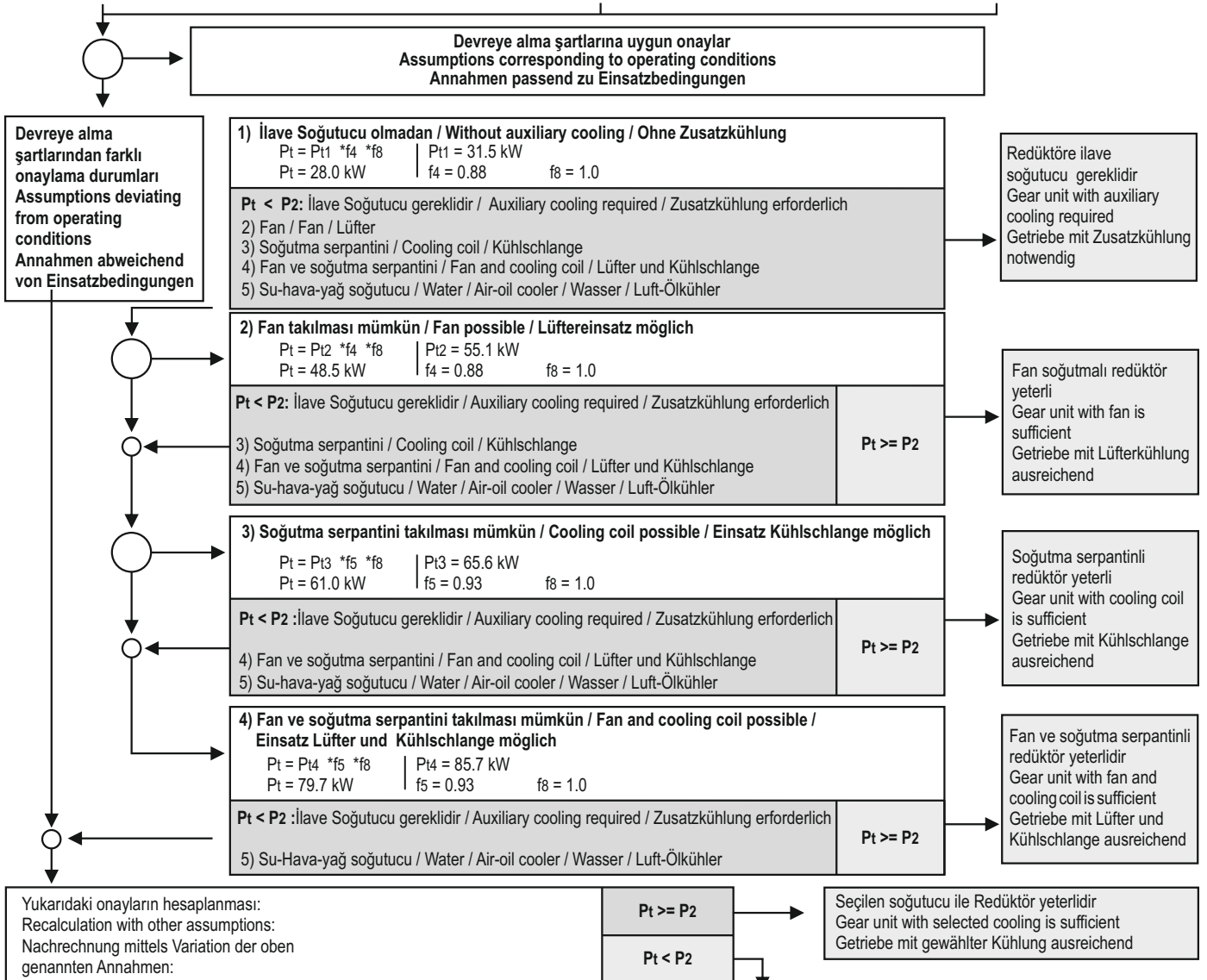

$i_N = 45$ değerli seçilen PB53-SH kodlu redüktör modeline uygun bir ilave soğutucu aksamı takılır. Müşterinin tesisindeki şartlara göre, en az bir adet fan veya soğutma serpantini takılır.

For the selected gear unit PB53-SH with $i_N=45$ suitable auxiliary cooling is to be provided. Dependent on the operating conditions at the customer's, at least a fan or a cooling coil is to be provided.

Das gewählte Getriebe PB53-SH mit $i_N = 45$ ist mit einer geeigneten Zusatzkühlung auszurüsten. Je nach Einsatzbedingungen beim Kunden ist mindestens ein Lüfter oder eine Kühlschlange vorzusehen.

Tablo 1 Tahrik makinaları için faktör f1

Table 1 Factor for driven machines f1

Tabelle 1 Arbeitsmaschinenfaktor f1

Tahrik Makinaları / Driven Machines / Arbeitsmaschinen			1)		
			≤ 0.5	> 0.5-10	> 10
Atık Su	Waste water treatment	Abwasser			
Yoğunlaştırıcılar (merkezi tahrikli)	Thickeners (central drive)	Eindicker (Zentralantrieb)	-	-	1.2
Filtre presleri	Filter presses	Filterpressen	1.0	1.3	1.5
Kabartma Malaksörleri	Flocculation apparatus	Flockungsrührer	0.8	1.0	1.3
Santrifüj Havalandırıcılar	Aerators	Kreiselbelüfter	-	1.8	2.0
Bilgisayar tesisleri	Raking equipment	Rechenanlagen	1.0	1.2	1.3
Dairesel ve Doğrusal Sıyırıcılar	Combined longitudinal and rotary rakes	Rund-und Längsräumer	1.0	1.3	1.5
Ön Yoğunlaştırıcılar	Pre-thickeners	Voreindicker	-	1.1	1.3
Salyangoz Su Pompaları	Screw pumps	Wasserschneckenpumpen	-	1.3	1.5
Su türbinleri	Water turbines	Wasserturbinen	-	-	2.0
Pompalar	Pumps	Pumpen			
Santrifüj pompalar	Centrifugal pumps	Kreiselpumpen	1.0	1.2	1.3
Tazyikli Pompalar	Positive-displacement pumps	Verdrängerpumpen			
1 piston	1 piston	1 Kolben	1.3	1.4	1.8
> 1 piston	> 1 piston	> 1 Kolben	1.2	1.4	1.5
Elavatörler	Dredgers	Bagger			
Kovalı Elavatörler	Bucket conveyors	Eimerketten	-	1.6	1.6
Damperli Araçlar	Dumping devices	Kippwerke	-	1.3	1.5
Paletli Araçlar	Caterpillar travelling gears	Raupenfahrzeuge	1.2	1.6	1.8
Küreme Ekskavatörleri	Bucket wheel excavators	Schaufelräder			
Hammadde Taşıcıları	As pick-up	Als Aufnehmer	-	1.7	1.7
	For primitive material	Für urmaterial	-	2.2	2.2
Doğrama Üniteleri	Cutter heads	Schneidköpfe	-	2.2	2.2
Kaldırma Vinçleri	Slewing gears *	Schwenkwerke *	-	1.4	1.8
Sac Kıvrırma Makineleri	Plate bending machines *	Blecbiegemaschinen	-	1.0	1.0
Kimya Endüstrisi	Chemical Industry	Chemische Industrie			
Ekstrüzyon Makineleri	Extruders	Extruder	-	-	1.6
Yoğurma Makineleri	Dough mills	Gummiknetter	-	1.8	1.8
Perdah Makineleri	Rubber calenders	Gummikalander	-	1.5	1.5
Soğutma Tamburları	Cooling drums	Kühltrommeln	-	1.3	1.4
Mikserler	Mixers for	Mischer für			
Eşit Orantılı Malzeme	Uniform media	Gleichmäßiger Gut	1.0	1.3	1.4
Orantsız Malzeme	Non-uniform media	Ungleichmäßiger Gut	1.4	1.6	1.7
Malzeme Karıştırıcılar	Agitators for media with	Rührwerke für Rührgut mit			
Eşit Orantılı Yoğunlukta	Uniform density	Gleichmäßiger Dichte	1.0	1.3	1.5
Orantsız Yoğunlukta	Non-uniform density	Ungleichmäßiger Dichte	1.2	1.4	1.6
Orantsız Gazlama Tesisleri	Non-uniform gas absorption	Ungleichmäßige Begasung	1.4	1.6	1.8
Tost Makineleri	Toasters	Toaster	1.0	1.3	1.5
Santrifüjler	Centrifuges	Zentrifugen	1.0	1.2	1.3
Demir Metalürjisi	Metal working mills	Eisenhüttenwesen			
Sac Haddehaneleri	Plate tilters	Blechwender	1.0	1.0	1.2
Tomruk İtçiler	Ingot pushers	Blockdrücker	1.0	1.2	1.2
Sarma Makineleri	Winding machines	Haspeln	-	1.6	1.6
Soğutma Yatağına İtçiler	Cooling bed transfer frames	Kühlbettschieber	-	1.5	1.5
Makara Düzeltme Makineleri	Roller straighteners	Rollenrichtmaschinen	-	1.6	1.6
Merdane Yollu Tablalar	Roller tables	Rollgänge			
Yollu Tablalar	Continuous	Durchlauf	-	1.5	1.5
Sarsıntılı	Intermittent	Stoßartig	-	2.0	2.0
Boru Haddehaneleri	Reversing tube mills	Rohr-revers	-	1.8	1.8
Makaslar	Shears	Scheren			
Sürekli Kesim *	Continuous *	Kontschnitt *	-	1.5	1.5
Krank Tipi Kesim *	Crank type *	Kurbelschnitt *	1.0	1.0	1.0
Kesintisiz Döküm Sürücülere *	Continuous casting drives*	Strangusstreiber *	-	1.4	1.4
Tüp değirmenler	Rolls	Walzen			
Haddehaneler	Reversing blooming mills	Blech-revers	-	2.5	2.5
Kütük Demir Haddehaneleri	Reversing slabbing mills	Brammen-revers	-	2.5	2.5
Tel Haddehaneleri	Reversing wire mills	Draht-revers	-	1.8	1.8
İnce Sac Haddehaneleri	Reversing sheet mills	Feinblech-revers	-	2.0	2.0
Kaba Sac Haddehaneleri	Reversing plate mills	Grobblech-revers	-	1.8	1.8
Silindir Ayarlamalı Sürücülere	Roll adjustment drives	Walzenanstellungen	0.9	1.0	-

TR SERVİS FAKTÖRÜ - KULLANIM ALANLARI

EN SERVICE FACTORS - APPLICATION AREAS

DE BETRIEBSFAKTOREN - EINSATZGEBIETE

Tablo 1 Tahrik makinaları için faktör f1

Table 1 Factor for driven machines f1

Tabelle 1 Arbeitsmaschinenfaktor f1

Tahrik Makinaları / Driven Machines / Arbeitsmaschinen			1)		
			≤ 0.5	> 0.5-10	> 10
Taşıyıcı Tertibatlar	Conveyors	Förderanlagen			
Kovalı Elavatörler	Bucket conveyors	Becherwerke	-	1.4	1.5
Maden Ocağı Vinçleri	Hauling winches	Förderhaspel	1.4	1.6	1.6
Taşıyıcı Makineler	Hoists	Fördermaschinen	-	1.5	1.8
Kayışlı Taşıyıcılar ≤150kW	Belt conveyors ≤150kW	Gurtbandförderer ≤150kW	1.0	1.2	1.3
Kayışlı Taşıyıcılar ≥150kW	Belt conveyors ≥150kW	Gurtbandförderer ≥150kW	1.1	1.3	1.4
Yük Asansörleri *	Goods lifts *	Lastaufzüge *	-	1.2	1.5
İnsan Taşıma Asansörleri *	Passenger lifts *	Personenaufzüge *	-	1.5	1.8
Yürüyen Bantlar	Apron conveyors	Plattenbänder	-	1.2	1.5
Yürüyen Merdivenler	Escalators	Rolltreppen	1.0	1.2	1.4
Raylı Araçlar	Railway vehicles	Schienenfahrzeuge	-	1.5	-
Frekans Dönüştürücüler	Frequency converters	Frequenzumformer	-	1.8	2.0
Piston Sıkıştırıcılar	Reciprocating compressors	Kolbenverdichter	-	1.8	1.9
Vinç Tertibatları **	Cranes **	Krananlagen**			
Torna Tertibatları	Slewing gears *	Drehwerke	1.0	1.4	1.8
Kaldırma Tertibatları	Lufting gears	Einziehwerke	1.0	1.1	1.4
Vasıta Hareket Tertibatları	Travelling gears	Fahrwerke	1.1	1.6	2.0
Kaldırma Tertibatları	Hoisting gears	Hubwerke	1.0	1.1	1.4
Kollu Vinç Tertibatları	Derricking jib cranes	Wippwerke	1.0	1.2	1.6
Soğutma Kuleleri	Cooling towers	Kühltürme			
Soğutma kulesi fanları	Cooling tower fans	Kühlturmflüfter	-		2.0
Havalandırıcılar (Eksenel ve radyal)	Blowers (axial and radial)	Gebläse (axial und radial)	-	1.4	1.5
Gıda Maddeleri Sanayi	Food industry	Nahrungsmittelindustrie			
Ham Şeker Üretimi	Cane sugar production	Rohrzuckerherstellung			
Şeker Kamışı Bıçakları *	Cane knives *	Zuckerrohnmesser *	-	-	1.7
Şeker Kamışı Değirmenleri *	Cane mills	Zuckerrohnmühle *	-	-	1.7
Pancar Şekeri Üretimi	Beet sugar production	Rübenzuckerherstellung			
Pancar Kesme Makineleri	Beet cassettes macerators	Schnitzelmaische	-	-	1.2
Vakumlu Kazanlar	Extraction plants Mechanical refrigerators	Extraktionsanlage Kuhlmaschine	-	-	1.4
Pancar Yıkama Makineleri	Juice boilers	Kochapparat	-	-	1.5
Kesme Makineleri	Sugar beet washing machines Sugar beet cutters	Rübenwäsche Schneidmaschine	-	-	1.5
Kağıt İmalat Makineleri	Paper machines	Papiermaschinen			
Her Tür ***	of all kind ***	alle Arten ***	-	1.8	2.0
Kağıt Hamuru Makineleri (istek üzerine)	Pulper drives (on request)	Pulperantriebe (auf Anfrage)	-	1.8	2.0
Santrifüjlü Kompresörler	Centrifugal compressors	Rotierende Verdichter	-	1.4	1.5
Teleferik Hatları	Cableways	Seilbahnen			
Malzeme Teleferik Hatları	Material ropeways	Materialbahnen	-	1.3	1.4
Havada Asılı Teleferik Hatları	To-and-fro system aerial ropeways	Pendelbahnen	-	1.6	1.8
Kayak Teleferik Hatları	T-bar lifts	Schlepplifte	-	1.3	1.4
Tek Kablo lu Teleferikler	Continuous ropeways	Umlaufbahnen	-	1.4	1.6
Çimento Sanayi	Cement industry	Zementindustrie			
Beton Karıştırıcıları	Concrete mixers	Betonmischer	-	1.5	1.5
Kırıcılar *	Breakers *	Brecher *	-	1.2	1.4
Döner fırınlar	Rotary kilns	Drehöfen	-	-	2.0
Silindirik Değirmenler	Tube mills	Rohrmühle	-	-	2.0
Seperatörler	Seperators	Sichter	-	1.6	1.6
Silindirik Değirmenler	Roll crushers	Walzenmühlen	-	-	2.0

TR SERVİS FAKTÖRÜ

EN SERVICE FACTORS

DE BETRIEBSFAKTOREN

P₂ gücü iş makinelerinin seçiminde:

*) Seçim, max. moment değerine göre yapılmalı

***) Maruz kalınan yük sınıfının doğru sınıflandırması, örneğin FEM 1001 göre yapılabilir.

****) Termal kapasite mutlaka gereklidir.

Burada belirtilen değerler, tecrübeyle tespit edilmiş değerlerdir. Burada belirtilen makine veya tertibatlar kapsamında uygulamanız için, genel olarak bilinen imalat ve yük şartlarının geçerli olduğu varsayılır. Ancak, uygulamanızın normal bilinenlerden farklı olması halinde ve burada yer verilmemiş iş makineleri için, mutlaka işletmemizle görüşmelisiniz.

1) Yük altında günlük çalışma süresi, saat cinsinden belirtilmelidir.

Design for power rating of driven machine P₂

*) Designed power corresponding to max. torque.

***) Load can be exactly classified, for instance, according to FEM 1001.

****) A check for thermal capacity is absolutely essential.

The listed factors are empirical values. Prerequisite for their application is that the machinery and equipment mentioned correspond to generally accepted design and load specifications. In case of deviations from standard conditions, please refer to us. For driven machines which are not listed in this table, please refer to us.

1) Effective daily operating period under load in hours.

Auslegung für Arbeitsmaschinenleistung P₂

*) Auslegung entsprechend dem Maximalmoment

***) Genaue Einstufung der Belastung kann z.B. nach FEM 1001 erfolgen.

****) Thermische Überprüfung generell erforderlich.

Die aufgeführten Faktoren sind Erfahrungswerte. Ihre Anwendung setzt für die genannten Maschinen oder Anlagen hierfür allgemein bekannte Konstruktions- und Belastungsbedingungen voraus. Bei Abweichung von Normalbedingungen ist Rückfrage erforderlich.

Für nicht aufgeführte Arbeitsmaschinen bitten wir um Rückfrage.

1) Tatsächliche tägliche Laufzeit unter Last in Stunden.

Tablo 2 / Table 2 / Tabelle 2		Tablo 3 / Table 3 / Tabelle 3				
Harekete geçiren (tahrik) makine faktörü / Factor for prime mover / Antriebsmaschinenfaktor	f ₂	Pik moment faktörü / Peak torque factor / Spitzenmomentfaktor f ₃				
Elektrik motorları, Hidrolik motorlar, Türbinler Electric motors, hydraulic motors, turbines Elektromotoren, Hydromotoren, Turbinen	1.0	Saatteki en yüksek moment sayısı Load peaks per hour / Belastungsspitzen pro Stunde	1 - 5	6 - 30	31 - 100	> 100
4-6 silindirli motorlar, uyumsuzluk derecesi 1:100-1:200 arası Piston engines 4-6 cylinders, cyclic variation 1:100 to 1:200 / Kolbenmaschinen 4-6 Zylinder, Ungleichförmigkeitsgrad 1:100 bis 1:200	1.25	Sabit yük yönü Steady direction of load Gleichbleibende Lastrichtung	0.5	0.65	0.7	0.85
1-3 silindirli motorlar, uyumsuzluk derecesi 1:100 Piston engines 1-3 cylinders, cyclic variation up to 1:100 / Kolbenmaschinen 1-3 Zylinder Ungleichförmigkeitsgrad 1:100	1.5	Değişen yük yönü Alternating direction of load Wechselnde Lastrichtung	0.7	0.95	1.10	1.25

Tablo 4 / Table 4 / Tabelle 4									
Termal faktör / Thermal factor / Wärmefaktor	(İlave soğutucu veya fan soğutucusu olmayan Redüktörler) (Gear units without auxiliary cooling or with fan) (Getriebe ohne Zusatzkühlung oder mit Lüfterkühlung)								
Ortam sıcaklığı / Ambient temperature Umgebungstemperatur	10°C	15°C	20°C	25°C	30°C	35°C	40°C	45°C	50°C
f ₄	1.11	1.06	1.00	0.94	0.88	0.82	0.75	0.69	0.63

Tablo 5 / Table 5 / Tabelle 5									
Termal faktör / Thermal factor / Wärmefaktor	(Soğutucu serpantinli veya fan ve soğutucu serpantinli) (For cooling with cooling coil, or with fan and cooling coil) (Mit Kühlung durch Kühlschlange oder mit Kühlung durch Lüfter und Kühlschlange)								
Ortam sıcaklığı / Ambient temperature Umgebungstemperatur	10°C	15°C	20°C	25°C	30°C	35°C	40°C	45°C	50°C
f ₅	1.05	1.03	1.00	0.97	0.93	0.90	0.87	0.84	0.81

Tablo 8 / Table 8 / Tabelle 8									
Dikey redüktörlerde yağlama faktörü. Yatay Redüktörlerde f ₈ = 1.0, ve basınçlı yağlamada f ₈ = 1.05 Oil supply factor for vertical gear units. For horizontal gear units f ₈ = 1.0, and in case of forced lubrication f ₈ = 1.05 Ölversorgungsfaktor bei vertikalgetriebenen. Bei Horizontalgetriebenen f ₈ = 1.0, und f ₈ = 1.05 bei druckschmierung									
Redüktör tipi Gear unit type Getriebebauart	Yağ Şekli Oil supply Ölversorgung	Boyut / Sizes / Größen 4... - 12...				Boyut / Sizes / Größen 13... - 18...			
		Olmadan Without / ohne İlave soğutucu Auxiliary cooling Zusatzkühlung	Birlikte With / mit Fan Lüfter	Birlikte With / mit Soğutma Cooling coil Kühlschlange	Birlikte With / mit Fan ve soğutma Fan and cooling coil Lüfter und Kühlschlange	Olmadan Without / ohne İlave soğutucu Auxiliary cooling Zusatzkühlung	Birlikte With / mit Fan Lüfter	Birlikte With / mit Soğutma Cooling coil Kühlschlange	Birlikte With / mit Fan ve soğutma Fan and cooling coil Lüfter und Kühlschlange
PH...2-V PH...3-V PH...4-V	Daldırmalı yağlama Dip lubrication Tauchschmierung	0.95	#	0.95	#	#	#	#	#
	Basınçlı yağlama Forced lubrication Druckschmierung	1.15	#	1.05	#	1.15	#	1.05	#
PB...2-V PB...3-V PB...4-V	Daldırmalı yağlama Dip lubrication Tauchschmierung	0.95	0.95	0.95	0.95	#	#	#	#
	Basınçlı yağlama Forced lubrication Druckschmierung	1.15	1.10	1.10	1.10	1.15	1.10	1.10	1.10

#) Talep edildiğinde

#) On request

#) Auf Anfrage

Seçim Tabloları

Selection of Gear Unit

Auswahl Des Getriebes

PH...

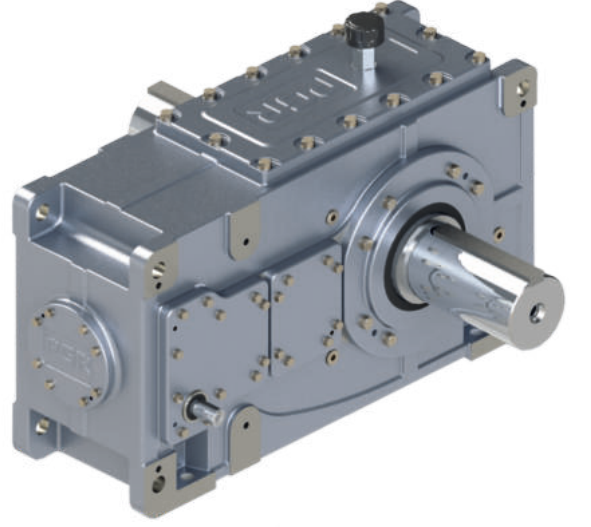

PB...

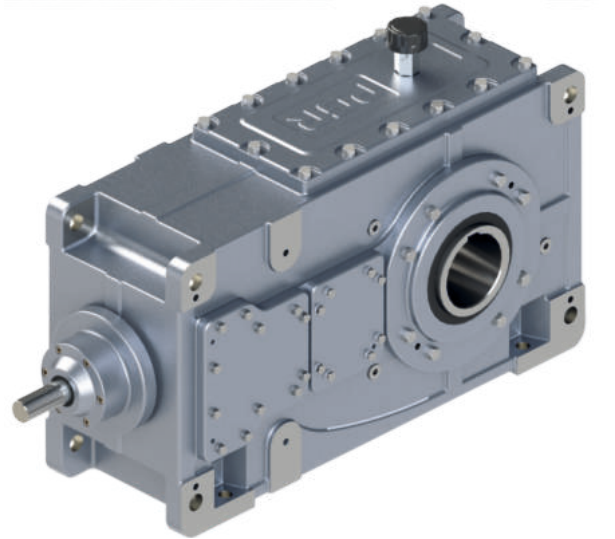

PH / PB

TR NOMİNAL GÜÇ DEĞERİ P_{2N} (kW)EN NOMINAL POWER RATINGS P_{2N} (kW)DE NENNLEISTUNGEN P_{2N} (kW)

iN	n1 [min ⁻¹]	n2 [min ⁻¹]	Redüktör Gövdeleri / Gear unit sizes / Getriebegrößen																			
			31	41	51	61	71	81	91	101	111	121	131	141	151	161	171	181	191	201	211	221
1.25	1800	1440	446		1230		2337*		3798*		-		-		-		-		-		-	
	1500	1200	371		1025		1947		3165		-		-		-		-		-		-	
	1200	960	297		820		1558		2532		-		-		-		-		-		-	
	1000	800	247		683		1298		2110		-		-		-		-		-		-	
1.4	1800	1286	425		1126		2184*		3516*		-		-		-		-		-		-	
	1500	1071	354		937		1819		2927		-		-		-		-		-		-	
	1200	857	284		750		1455		2343		-		-		-		-		-		-	
	1000	714	236		625		1212		1951		-		-		-		-		-		-	
1.6	1800	1125	396		1033		1958*		3256*		-		-		-		-		-		-	
	1500	938	330		861		1632		2714		4608		-		-		-		-		-	
	1200	750	264		689		1306		2171		3684		-		-		-		-		-	
	1000	625	219		573		1087		1808		3070		4498		-		-		-		-	
1.8	1800	1000	288		939		1857*		2990*		5084*		-		-		-		-		-	
	1500	833	240		782		1547		2491		4234		-		-		-		-		-	
	1200	667	192		626		1239		1994		3390		5050*		-		-		-		-	
	1000	556	160		522		1033		1663		2826		4210		-		-		-		-	
2.0	1800	900	268		903		1711*		2758*		4720*		-		-		-		-		-	
	1500	750	223		753		1425		2298		3933		-		-		-		-		-	
	1200	600	179		602		1140		1839		3146		4672*		-		-		-		-	
	1000	500	149		502		950		1532		2621		3892		-		-		-		-	
2.24	1800	804	240		824		1528*		2464*		4344*		-		-		-		-		-	
	1500	670	200		686		1273		2053		3620		-		-		-		-		-	
	1200	536	160		549		1019		1642		2896		4304*		-		-		-		-	
	1000	446	133		457		848		1367		2410		3581		-		-		-		-	
2.5	1800	720	222		737		1368*		2206*		3890*		-		-		-		-		-	
	1500	600	186		615		1140		1839		3243		4934*		-		-		-		-	
	1200	480	148		492		912		1471		2594		3947*		-		-		-		-	
	1000	400	123		410		760		1226		2161		3290		4998		-		-		-	
2.8	1800	643	212		659		1174*		1868*		3474*		-		-		-		-		-	
	1500	536	176		549		978		1557		2896		4407*		-		-		-		-	
	1200	429	142		440		783		1245		2318		3527*		-		-		-		-	
	1000	357	117		365		652		1036		1929		2936		4575		-		-		-	
3.15	1800	571	189		584		1061		1714		2933*		4457*		-		-		-		-	
	1500	476	157		488		884		1428		2445		3716		-		-		-		-	
	1200	381	125		390		708		1143		1956		2974		5046*		-		-		-	
	1000	317	104		324		589		951		1628		2475		4198		-		-		-	
3.55	1800	507	172		514		963		1548		2718*		4028*		-		-		-		-	
	1500	423	144		428		804		1291		2267		3361		-		-		-		-	
	1200	338	115		343		642		1032		1812		2686		4548*		-		-		-	
	1000	282	95.9		286		536		861		1512		2240		3794		-		-		-	
4.0	1800	450	153		461		855		1379		2432*		3638*		-		-		-		-	
	1500	375	128		384		712		1149		2026		3031		-		-		-		-	
	1200	300	102		307		570		919		1621		2426		4165*		-		-		-	
	1000	250	84.7		256		474		766		1350		2021		3471		4619		-		-	
4.5	1800	400	106		328		674		1051		1965		2632*		4656*		-		-		-	
	1500	333	88.7		273		561		874		1635		2190		3876		-		-		-	
	1200	267	70.4		219		450		701		1312		1756		3108		4163*		-		-	
	1000	222	59.2		182		374		582		1090		1460		2584		3461		-		-	
5.0	1800	360	91.8		276		530		903		1487		2241*		3653*		4767*		-		-	
	1500	300	76.5		231		442		753		1239		1868		3044		3973		-		-	
	1200	240	61.2		184		353		602		991		1494		2435		3178		4459*		-	
	1000	200	51.0		153		295		502		826		1244		2029		2648		3716		-	
5.6	1800	321	78.5		236		449		689		1251		1899*		3099*		4045*		-		-	
	1500	268	65.3		197		374		575		1044		1585		2587		3377*		4293*		-	
	1200	214	52.0		157		299		459		833		1266		2066		2697		3428*		-	
	1000	179	43.9		132		250		384		698		1059		1728		2255		2867		-	

■ Yatay redüktörlerde basınçlı yağlama gereklidir.

■ Forced lubrication required on horizontal gear units

■ Druckschmierung bei Horizontalgetrieben erforderlich

✳ Talep edildiğinde yapılan redüktörler.

✳ Gear units only on request

✳ Getriebe nur auf Anfrage

TR NÖMİNAL ÇIKIŞ MOMENTLERİ T_{2N} (kNm)

EN NOMINAL OUTPUT TORQUES T_{2N} (kNm)

DE NENN-ABTRIEBSDREHMOMENTE T_{2N} (kNm)

İN	Redüktör Gövdeleri / Gear unit sizes / Getriebegrößen																			
	31	41	51	61	71	81	91	101	111	121	131	141	151	161	171	181	191	201	211	221
1.25	2.96		8.16		16.0		25.0		-		-		-		-		-			
1.4	3.16		8.36		16.0		26.0		-		-		-		-		-			
1.6	3.37		8.77		17.0		28.0		47.0		68.7		-		-		-			
1.8	2.75		8.98		18.0		29.0		49.0		72.3		-		-		-			
2.0	2.86		9.59		18.0		29.0		50.0		74.4		132		-		-			
2.24	2.86		9.79		18.0		29.0		52.0		76.7		133		-		-			
2.5	2.96		9.79		18.0		29.0		52.0		78.5		119		-		-			
2.8	3.16		9.79		17.0		28.0		52.0		78.5		122		174		-			
3.15	3.16		9.79		18.0		29.0		49.0		74.6		126		176		-			
3.55	3.26		9.69		18.0		29.0		51.0		75.9		129		176		-			
4.0	3.26		9.79		18.0		29.0		52.0		77.2		133		176		250			
4.5	2.55		7.85		16.0		25.0		47.0		62.8		111		149		220			
5.0	2.45		7.34		14.0		24.0		39.0		59.5		96.9		126		177			
5.6	2.35		7.04		13.0		21.0		37.0		56.5		92.2		120		153			

TR TERMAL KAPASİTELER Pt (kW)

EN THERMAL CAPACITIES Pt (kW)

DE WÄRMEGRENZLEISTUNGEN Pt (kW)

İN	Pt (kW)	Redüktör Gövdeleri / Gear unit sizes / Getriebegrößen																			
		31	41	51	61	71	81	91	101	111	121	131	141	151	161	171	181	191	201	211	221
1.25	Pt1	64.5		*		*		*		-		-		-		-		-		-	
	Pt2	191		410		527		547		-		-		-		-		-		-	
	Pt3	276		652		929		1314		-		-		-		-		-		-	
	Pt4	385		953		1348		1819		-		-		-		-		-		-	
1.4	Pt1	66.7		*		*		*		-		-		-		-		-		-	
	Pt2	190		417		545		590		-		-		-		-		-		-	
	Pt3	269		642		910		1303		-		-		-		-		-		-	
	Pt4	373		934		1324		1795		-		-		-		-		-		-	
1.6	Pt1	70.0		*		*		*		*		*		*		*		*		*	
	Pt2	187		420		551		643		744		520		-		-		-		-	
	Pt3	253		607		850		1255		2098		2508		-		-		-		-	
	Pt4	354		887		1238		1740		2895		3379		-		-		-		-	
1.8	Pt1	81.5		*		*		*		*		*		*		*		*		*	
	Pt2	209		418		572		668		837		687		-		-		-		-	
	Pt3	274		572		835		1211		2066		2465		-		-		-		-	
	Pt4	384		844		1220		1683		2858		3329		-		-		-		-	
2.0	Pt1	80.1		106		*		*		*		*		*		*		*		*	
	Pt2	201		405		560		664		869		772		*		*		*		*	
	Pt3	261		542		794		1153		1994		2415		2114		*		*		*	
	Pt4	365		795		1158		1604		2754		3254		3178		*		*		*	
2.24	Pt1	79.6		111		*		*		*		*		*		*		*		*	
	Pt2	193		390		530		658		905		868		533		*		*		*	
	Pt3	246		506		718		1084		1901		2336		2089		*		*		*	
	Pt4	345		748		1050		1515		2640		3166		3134		*		*		*	
2.5	Pt1	74.3		110		*		*		*		*		*		*		*		*	
	Pt2	179		369		504		633		902		906		633		*		*		*	
	Pt3	220		468		662		1006		1788		2217		2056		*		*		*	
	Pt4	310		693		969		1409		2486		3014		3056		*		*		*	
2.8	Pt1	71.0		107		136		*		*		*		*		*		*		*	
	Pt2	167		347		521		662		882		920		721		510		*		*	
	Pt3	203		427		668		1014		1658		2075		1996		2247		*		*	
	Pt4	287		632		978		1418		2310		2825		2950		3287		*		*	
3.15	Pt1	74.5		130		193		221		*		*		*		*		*		*	
	Pt2	164		355		613		746		1039		1151		1169		1061		*		*	
	Pt3	197		424		784		1113		1716		2117		2223		2567		*		*	
	Pt4	275		624		1163		1579		2396		2901		3237		3696		*		*	
3.55	Pt1	69.0		130		182		213		*		*		*		*		*		*	
	Pt2	150		347		564		696		968		1100		1163		1118		*		*	
	Pt3	177		406		703		1008		1549		1934		2068		2435		*		*	
	Pt4	249		597		1048		1435		2171		2655		3001		3480		*		*	
4.0	Pt1	63.1		120		170		193		240		*		*		*		*		*	
	Pt2	137		315		508		597		909		1044		1146		1155		*		1053	
	Pt3	158		360		616		836		1399		1749		1888		2256		*		*	
	Pt4	221		531		920		1199		1966		2411		2746		3221		*		*	
4.5	Pt1	71.1		132		187		243		272		310		*		*		*		*	
	Pt2	147		322		514		680		889		1129		1315		1333		*		1299	
	Pt3	168		361		611		926		1336		1819		1946		2272		*		*	
	Pt4	235		531		907		1320		1892		2523		2815		3233		*		*	
5.0	Pt1	65.2		128		188		233		296		347		*		*		*		*	
	Pt2	134		307		498		620		886		1109		1343		1572		*		1617	
	Pt3	150		340		575		817		1268		1720		1856		2472		*		*	
	Pt4	209		500		858		1168		1805		2395		2695		3516		*		*	
5.6	Pt1	58.3		113		169		224		283		317		*		*		*		*	
	Pt2	118		271		444		593		839		998		1219		1444		*		1698	
	Pt3	131		294		504		760		1187		1508		1640		2200		*		*	
	Pt4	183		434		754		1092		1696		2106		2385		3130		*		*	

* Talep edildiğinde

A) Değerler aşağıda belirtilen şartlar için geçerlidir:

Saatlik çalışma döngüsü: %100

Büyük bir alanda kurulum rakım 1000 m'ye kadar

B) Değerler aşağıda belirtilen şartlar için geçerlidir:

Soğutma suyu, çıkış su sıcaklığı ne olursa olsun, soğuk su giriş sıcaklığı 20°C olmalıdır.

Soğutma suyu çıkış sıcaklığının sınırlanmasına ilişkin hesaplama, ancak talep edildiğinde sağlanır.

* On request

A) Values refer to:

Operating cycle: 100%

Installation in a large hall Altitude up to 1000 m

B) Values refer to:

A cooling water inlet temperature of 20°C with unlimited cooling water outlet temperature.

A recalculation with a limited cooling water outlet temperature is possible on request.

* Auf Anfrage

A) Werte gelten für:

Einschaltdauer: 100%

Aufstellung in großer Halle Höhenlage bis 1000 m

B) Werte gelten für:

Eine Kühlwassereintrittstemperatur von 20°C ohne Begrenzung der Kühlwasseraustrittstemperatur.

Die Nachrechnung mit Begrenzung der Kühlwasser austrittstemperatur ist auf Anfrage möglich.

Pt1 Redüktörler, ilave soğutucusu yok. A

Pt2 Redüktörler, fan soğutucusu. A

Pt3 Redüktörler, monte edilmiş serpantinli soğutucu. A,B

Pt4 Redüktörler, fanlı ve monte edilmiş serpantinli soğutucu. A,B

Pt1 Gear units without auxiliary cooling A

Pt2 Gear units with fan A

Pt3 Gear units with built-in cooling coil A,B

Pt4 Gear units with fan and built-in cooling coil A,B

Pt1 Getriebe ohne Zusatzkühlung A

Pt2 Getriebe mit Lüfterkühlung A

Pt3 Getriebe mit eingebauter Kühlschlange A,B

Pt4 Getriebe mit Lüfter und eingebauter Kühlschlange A,B

TR TERMAL KAPASİTELER Pt (kW)

EN THERMAL CAPACITIES Pt (kW)

DE WÄRMEGRENZLEISTUNGEN Pt (kW)

İN	Pt (kW)	Redüktör Gövdeleri / Gear unit sizes / Getriebegrößen																			
		31	41	51	61	71	81	91	101	111	121	131	141	151	161	171	181	191	201	211	221
1.25	Pt1	*		*		*		*		-		-		-		-		-		-	
	Pt2	205		405		490		455		-		-		-		-		-		-	
	Pt3	302		679		941		1279		-		-		-		-		-		-	
	Pt4	441		1071		1497		1985		-		-		-		-		-		-	
1.4	Pt1	*		*		*		*		-		-		-		-		-		-	
	Pt2	205		418		517		511		-		-		-		-		-		-	
	Pt3	295		673		931		1285		-		-		-		-		-		-	
	Pt4	428		1054		1476		1971		-		-		-		-		-		-	
1.6	Pt1	58.0		*		*		*		*		*		*		*		*		*	
	Pt2	204		432		544		596		539		*		*		*		*		*	
	Pt3	278		647		886		1271		1962		2120		*		*		*		*	
	Pt4	408		1007		1392		1932		3106		3474		*		*		*		*	
1.8	Pt1	70.5		*		*		*		*		*		*		*		*		*	
	Pt2	230		438		581		646		683		*		*		*		*		*	
	Pt3	304		616		883		1250		1997		2200		*		*		*		*	
	Pt4	443		961		1379		1883		3110		3502		*		*		*		*	
2.0	Pt1	70.1		*		*		*		*		*		*		*		*		*	
	Pt2	222		426		573		651		732		*		*		*		*		*	
	Pt3	290		584		843		1196		1949		2193		1692		*		*		*	
	Pt4	421		907		1312		1800		3011		3448		3196		*		*		*	
2.24	Pt1	71.3		*		*		*		*		*		*		*		*		*	
	Pt2	214		416		552		660		808		638		*		*		*		*	
	Pt3	273		550		769		1139		1897		2191		1769		*		*		*	
	Pt4	399		856		1193		1709		2912		3402		3225		*		*		*	
2.5	Pt1	67.3		*		*		*		*		*		*		*		*		*	
	Pt2	199		397		528		644		826		705		*		*		*		*	
	Pt3	246		510		713		1063		1803		2114		1787		*		*		*	
	Pt4	359		794		1104		1592		2754		3260		3179		*		*		*	
2.8	Pt1	65.0		*		*		*		*		*		*		*		*		*	
	Pt2	187		373		551		680		828		753		*		*		*		*	
	Pt3	226		467		722		1078		1689		2008		1780		*		*		*	
	Pt4	332		726		1117		1608		2570		3076		3102		*		*		*	
3.15	Pt1	71.5		115		162		*		*		*		*		*		*		*	
	Pt2	185		393		671		805		1076		1131		1044		*		*		*	
	Pt3	221		472		865		1217		1834		2202		2219		*		*		*	
	Pt4	320		721		1340		1813		2722		3258		3571		*		*		*	
3.55	Pt1	66.3		116		156		*		*		*		*		*		*		*	
	Pt2	169		384		619		753		1010		1093		1061		*		*		*	
	Pt3	200		452		776		1105		1662		2023		2081		*		*		*	
	Pt4	290		690		1208		1648		2469		2989		3322		*		*		*	
4.0	Pt1	61.2		110		150		159		*		*		*		*		*		*	
	Pt2	154		351		560		650		961		1061		1086		*		*		*	
	Pt3	177		402		683		921		1512		1849		1932		*		*		*	
	Pt4	257		615		1063		1379		2244		2726		3061		*		*		*	
4.5	Pt1	69.8		123		172		215		*		*		*		*		*		*	
	Pt2	166		362		573		752		963		1191		1329		*		*		*	
	Pt3	190		405		682		1029		1465		1964		2052		*		*		*	
	Pt4	273		616		1051		1525		2174		2879		3180		*		*		*	
5.0	Pt1	64.5		123		177		215		253		*		*		*		*		*	
	Pt2	152		346		558		692		972		1194		1406		*		*		*	
	Pt3	169		383		646		912		1401		1880		1994		*		*		*	
	Pt4	244		580		996		1353		2082		2748		3069		*		*		*	
5.6	Pt1	57.7		109		160		206		242		*		*		*		*		*	
	Pt2	135		305		498		660		921		1075		1276		*		*		*	
	Pt3	148		330		566		850		1313		1648		1763		*		*		*	
	Pt4	212		504		874		1265		1955		2416		2715		*		*		*	

* Talep edildiğinde

A) Değerler aşağıda belirtilen şartlar için geçerlidir:

Saatlik çalışma döngüsü: %100

Büyük bir alanda kurulum rakım 1000 m'ye kadar

B) Değerler aşağıda belirtilen şartlar için geçerlidir:

Soğutma suyu, çıkış su sıcaklığı ne olursa olsun, soğuk su giriş sıcaklığı 20°C olmalıdır.

Soğutma suyu çıkış sıcaklığının sınırlanmasına ilişkin hesaplama, ancak talep edildiğinde sağlanır.

* On request

A) Values refer to:

Operating cycle: 100%

Installation in a large hall Altitude up to 1000 m

B) Values refer to:

A cooling water inlet temperature of 20°C with unlimited cooling water outlet temperature.

A recalculation with a limited cooling water outlet temperature is possible on request.

* Auf Anfrage

A) Werte gelten für:

Einschaltdauer: 100%

Aufstellung in großer Halle Höhenlage bis 1000 m

B) Werte gelten für:

Eine Kühlwassereintrittstemperatur von 20°C ohne Begrenzung der Kühlwasseraustrittstemperatur.

Die Nachrechnung mit Begrenzung der Kühlwasser austrittstemperatur ist auf Anfrage möglich.

Pt1 Redüktörler, ilave soğutucusu yok. A

Pt2 Redüktörler, fan soğutucusu. A

Pt3 Redüktörler, monte edilmiş serpantinli soğutucu. A,B

Pt4 Redüktörler, fanlı ve monte edilmiş serpantinli soğutucu. A,B

Pt1 Gear units without auxiliary cooling A

Pt2 Gear units with fan A

Pt3 Gear units with built-in cooling coil A,B

Pt4 Gear units with fan and built-in cooling coil A,B

Pt1 Getriebe ohne Zusatzkühlung A

Pt2 Getriebe mit Lüfterkühlung A

Pt3 Getriebe mit eingebauter Kühlschlange A,B

Pt4 Getriebe mit Lüfter und eingebauter Kühlschlange A,B

TR TERMAL KAPASİTELER Pt (kW)

EN THERMAL CAPACITIES Pt (kW)

DE WÄRMEGRENZLEISTUNGEN Pt (kW)

İN	Pt (kW)	Redüktör Gövdeleri / Gear unit sizes / Getriebegrößen																		n ₁ =1500 min ⁻¹			
		31	41	51	61	71	81	91	101	111	121	131	141	151	161	171	181	191	201	211	221		
1.25	Pt1	*		*		*		*		-		-		-		-		-		-			
	Pt2	214		379		416		*		-		-		-		-		-		-			
	Pt3	313		700		965		1302		-		-		-		-		-		-			
	Pt4	481		1139		1568		2031		-		-		-		-		-		-			
1.4	Pt1	*		*		*		*		-		-		-		-		-		-			
	Pt2	216		400		456		383		-		-		-		-		-		-			
	Pt3	305		694		956		1311		-		-		-		-		-		-			
	Pt4	468		1126		1553		2032		-		-		-		-		-		-			
1.6	Pt1	*		*		*		*		*		*		*		*		*		*			
	Pt2	217		428		510		505		*		*		*		*		*		*			
	Pt3	290		668		912		1302		1983		2101		*		*		*		*			
	Pt4	447		1084		1481		2022		3100		3251		*		*		*		*			
1.8	Pt1	*		*		*		*		*		*		*		*		*		*			
	Pt2	246		444		565		587		*		*		*		*		*		*			
	Pt3	315		638		912		1284		2030		2204		*		*		*		*			
	Pt4	488		1039		1479		1992		3168		3395		*		*		*		*			
2.0	Pt1	*		*		*		*		*		*		*		*		*		*			
	Pt2	239		436		564		602		519		*		*		*		*		*			
	Pt3	301		605		869		1231		1986		2204		1659		*		*		*			
	Pt4	464		983		1410		1910		3087		3379		2883		*		*		*			
2.24	Pt1	*		*		*		*		*		*		*		*		*		*			
	Pt2	232		430		555		632		644		*		*		*		*		*			
	Pt3	284		569		795		1174		1940		2215		1753		*		*		*			
	Pt4	440		931		1289		1826		3023		3403		3022		*		*		*			
2.5	Pt1	*		*		*		*		*		*		*		*		*		*			
	Pt2	215		413		536		626		690		*		*		*		*		*			
	Pt3	256		528		737		1097		1846		2144		1781		*		*		*			
	Pt4	396		865		1195		1707		2875		3293		3031		*		*		*			
2.8	Pt1	51.0		*		*		*		*		*		*		*		*		*			
	Pt2	203		392		564		671		719		*		*		*		*		*			
	Pt3	236		485		748		1113		1732		2042		1783		1873		*		*			
	Pt4	366		793		1213		1729		2700		3137		3006		3149		*		*			
3.15	Pt1	*		*		*		*		*		*		*		*		*		*			
	Pt2	204		423		716		845		1076		1054		832		*		*		*			
	Pt3	231		491		899		1262		1895		2265		2267		2537		*		*			
	Pt4	355		795		1471		1980		2937		3462		3707		4116		*		*			
3.55	Pt1	*		*		*		*		*		*		*		*		*		*			
	Pt2	187		415		662		794		1018		1034		877		692		*		*			
	Pt3	208		469		807		1146		1719		2083		2129		2435		*		*			
	Pt4	320		761		1327		1803		2669		3185		3465		3916		*		*			
4.0	Pt1	*		86.8		*		*		*		*		*		*		*		*			
	Pt2	169		381		603		691		983		1032		957		837		635		*			
	Pt3	185		418		710		956		1565		1907		1982		2308		*		*			
	Pt4	286		678		1170		1513		2435		2923		3222		3698		*		*			
4.5	Pt1	*		108		138		*		*		*		*		*		*		*			
	Pt2	184		397		623		811		1014		1217		1286		1216		1090		*			
	Pt3	198		421		710		1070		1519		2032		2117		2430		*		*			
	Pt4	304		682		1160		1679		2377		3123		3406		3855		*		*			
5.0	Pt1	*		113		154		172		*		*		*		*		*		*			
	Pt2	168		380		611		753		1040		1252		1423		1591		1557		*			
	Pt3	176		398		672		949		1456		1949		2062		2713		*		*			
	Pt4	271		644		1102		1493		2287		3001		3320		4286		*		*			
5.6	Pt1	57.1		101		139		166		*		*		*		*		*		*			
	Pt2	149		337		546		718		986		1126		1291		1462		1636		*			
	Pt3	154		344		589		883		1364		1709		1823		2414		*		*			
	Pt4	237		559		968		1397		2148		2638		2938		3816		*		*			

* Talep edildiğinde

A) Değerler aşağıda belirtilen şartlar için geçerlidir:

Saatlik çalışma döngüsü: %100

Büyük bir alanda kurulum rakım 1000 m'ye kadar

B) Değerler aşağıda belirtilen şartlar için geçerlidir:

Soğutma suyu, çıkış su sıcaklığı ne olursa olsun, soğuk su giriş sıcaklığı 20°C olmalıdır.

Soğutma suyu çıkış sıcaklığının sınırlanmasına ilişkin hesaplama, ancak talep edildiğinde sağlanır.

* On request

A) Values refer to:

Operating cycle: 100%

Installation in a large hall Altitude up to 1000 m

B) Values refer to:

A cooling water inlet temperature of 20°C with unlimited cooling water outlet temperature.

A recalculation with a limited cooling water outlet temperature is possible on request.

* Auf Anfrage

A) Werte gelten für:

Einschaltdauer: 100%

Aufstellung in großer Halle Höhenlage bis 1000 m

B) Werte gelten für:

Eine Kühlwassereintrittstemperatur von 20°C ohne Begrenzung der Kühlwasseraustrittstemperatur.

Die Nachrechnung mit Begrenzung der Kühlwasseraustrittstemperatur ist auf Anfrage möglich.

Pt1 Redüktörler, ilave soğutucusu yok. A

Pt2 Redüktörler, fan soğutucusu. A

Pt3 Redüktörler, monte edilmiş serpantinli soğutucu. A,B

Pt4 Redüktörler, fanlı ve monte edilmiş serpantinli soğutucu. A,B

Pt1 Gear units without auxiliary cooling A

Pt2 Gear units with fan A

Pt3 Gear units with built-in cooling coil A,B

Pt4 Gear units with fan and built-in cooling coil A,B

Pt1 Getriebe ohne Zusatzkühlung A

Pt2 Getriebe mit Lüfterkühlung A

Pt3 Getriebe mit eingebauter Kühlschlange A,B

Pt4 Getriebe mit Lüfter und eingebauter Kühlschlange A,B

TR TERMAL KAPASİTELER Pt (kW)

EN THERMAL CAPACITIES Pt (kW)

DE WÄRMEGRENZLEISTUNGEN Pt (kW)

İN	Pt (kW)	Redüktör Gövdeleri / Gear unit sizes / Getriebegrößen																			
		31	41	51	61	71	81	91	101	111	121	131	141	151	161	171	181	191	201	211	221
1.25	Pt1	*		*		*		*		-		-		-		-		-		-	
	Pt2	214		301		*		*		-		-		-		-		-		-	
	Pt3	320		663		868		1079		-		-		-		-		-		-	
	Pt4	524		1187		1585		1959		-		-		-		-		-		-	
1.4	Pt1	*		*		*		*		-		-		-		-		-		-	
	Pt2	218		334		306		*		-		-		-		-		-		-	
	Pt3	314		665		876		1118		-		-		-		-		-		-	
	Pt4	512		1181		1587		1992		-		-		-		-		-		-	
1.6	Pt1	*		*		*		*		*		*		*		*		*		*	
	Pt2	223		387		405		*		*		*		*		*		*		*	
	Pt3	300		656		865		1169		1494		*		*		*		*		*	
	Pt4	492		1154		1543		2042		2840		2535		*		*		*		*	
1.8	Pt1	*		*		*		*		*		*		*		*		*		*	
	Pt2	257		419		490		428		*		*		*		*		*		*	
	Pt3	329		635		884		1194		1658		1457		*		*		*		*	
	Pt4	538		1117		1562		2052		3031		2905		*		*		*		*	
2.0	Pt1	*		*		*		*		*		*		*		*		*		*	
	Pt2	250		417		501		463		*		*		*		*		*		*	
	Pt3	314		607		850		1158		1661		1533		*		*		*		*	
	Pt4	513		1060		1496		1982		2993		2967		2012		*		*		*	
2.24	Pt1	*		*		*		*		*		*		*		*		*		*	
	Pt2	245		422		514		529		*		*		*		*		*		*	
	Pt3	298		577		788		1127		1694		1684		*		*		*		*	
	Pt4	488		1010		1379		1917		3004		3131		2365		*		*		*	
2.5	Pt1	*		*		*		*		*		*		*		*		*		*	
	Pt2	228		410		506		543		*		*		*		*		*		*	
	Pt3	269		539		736		1064		1645		1694		*		*		*		*	
	Pt4	440		940		1284		1803		2891		3094		2486		*		*		*	
2.8	Pt1	*		*		*		*		*		*		*		*		*		*	
	Pt2	216		394		542		601		*		*		*		*		*		*	
	Pt3	249		496		752		1090		1574		1672		1175		*		*		*	
	Pt4	407		865		1309		1837		2744		3006		2567		2437		*		*	
3.15	Pt1	53.3		*		*		*		*		*		*		*		*		*	
	Pt2	221		447		741		849		986		824		*		*		*		*	
	Pt3	247		515		933		1293		1872		2139		1981		2092		*		*	
	Pt4	397		879		1619		2160		3135		3599		3683		3960		*		*	
3.55	Pt1	51.0		*		*		*		*		*		*		*		*		*	
	Pt2	203		440		689		804		949		840		*		*		*		*	
	Pt3	222		494		840		1179		1707		1986		1890		2052		*		*	
	Pt4	359		844		1463		1972		2860		3330		3475		3814		*		*	
4.0	Pt1	49.7		*		*		*		*		*		*		*		*		*	
	Pt2	185		406		632		709		945		896		640		*		*		*	
	Pt3	198		442		743		989		1573		1851		1815		2027		*		*	
	Pt4	319		754		1293		1661		2627		3089		3290		3685		*		*	
4.5	Pt1	62.2		*		*		*		*		*		*		*		*		*	
	Pt2	202		427		666		854		1025		1165		1103		944		*		*	
	Pt3	212		448		750		1122		1561		2039		2046		2290		*		*	
	Pt4	341		761		1290		1858		2598		3366		3590		4002		*		*	
5.0	Pt1	*		94.4		*		*		*		*		*		*		*		*	
	Pt2	186		414		659		804		1080		1255		1336		1421		*		*	
	Pt3	190		424		714		1003		1516		1995		2056		2657		*		*	
	Pt4	305		720		1230		1661		2520		3272		3564		4552		*		*	
5.6	Pt1	54.3		83.9		*		*		*		*		*		*		*		*	
	Pt2	164		365		589		767		1024		1129		1213		1306		*		*	
	Pt3	165		367		625		933		1420		1749		1817		2364		*		*	
	Pt4	266		625		1080		1553		2367		2876		3154		4052		*		*	

* Talep edildiğinde

A) Değerler aşağıda belirtilen şartlar için geçerlidir:

Saatlik çalışma döngüsü: %100

Büyük bir alanda kurulum rakım 1000 m'ye kadar

B) Değerler aşağıda belirtilen şartlar için geçerlidir:

Soğutma suyu, çıkış su sıcaklığı ne olursa olsun, soğuk su giriş sıcaklığı 20°C olmalıdır.

Soğutma suyu çıkış sıcaklığının sınırlanmasına ilişkin hesaplama, ancak talep edildiğinde sağlanır.

* On request

A) Values refer to:

Operating cycle: 100%

Installation in a large hall Altitude up to 1000 m

B) Values refer to:

A cooling water inlet temperature of 20°C with unlimited cooling water outlet temperature.

A recalculation with a limited cooling water outlet temperature is possible on request.

* Auf Anfrage

A) Werte gelten für:

Einschaltdauer: 100%

Aufstellung in großer Halle Höhenlage bis 1000 m

B) Werte gelten für:

Eine Kühlwassereintrittstemperatur von 20°C ohne Begrenzung der Kühlwasseraustrittstemperatur.

Die Nachrechnung mit Begrenzung der Kühlwasseraustrittstemperatur ist auf Anfrage möglich.

Pt1 Redüktörler, ilave soğutucusu yok. A

Pt2 Redüktörler, fan soğutucusu. A

Pt3 Redüktörler, monte edilmiş serpantinli soğutucu. A,B

Pt4 Redüktörler, fanlı ve monte edilmiş serpantinli soğutucu. A,B

Pt1 Gear units without auxiliary cooling A

Pt2 Gear units with fan A

Pt3 Gear units with built-in cooling coil A,B

Pt4 Gear units with fan and built-in cooling coil A,B

Pt1 Getriebe ohne Zusatzkühlung A

Pt2 Getriebe mit Lüfterkühlung A

Pt3 Getriebe mit eingebauter Kühlschlange A,B

Pt4 Getriebe mit Lüfter und eingebauter Kühlschlange A,B

TR NOMİNAL GÜÇ DEĞERLERİ P_{2N} (kW)EN NOMINAL POWER RATINGS P_{2N} (kW)DE NENNLEISTUNGEN P_{2N} (kW)

iN	n1 min-1	n2 min-1	Redüktör Gövdeleri / Gear unit sizes / Getriebegrößen																		
			42	52	62	72	82	92	102	112	122	132	142	152	162	172	182	192	202	212	222
6.3	1800	286	192	326	-	619	-	1029	-	1811	-	2627	-	4368*	-	-	-	-	-	-	-
	1500	238	160	271	-	515	-	856	-	1507	-	2186	-	3634	-	4956	-	-	-	-	-
	1200	190	128	216	-	411	-	683	-	1203	-	1744	-	2902	-	3957	-	-	-	-	-
	1000	159	106	182	-	344	-	572	-	1007	-	1460	-	2428	-	3311	-	4958	-	-	-
7.1	1800	254	175	303	-	550	-	914	-	1609	-	2333	-	3879*	4340*	-	-	-	-	-	-
	1500	211	146	252	-	457	-	759	-	1336	-	1938	-	3222	3606	4394	-	-	-	-	-
	1200	169	117	202	-	366	-	608	-	1070	-	1551	-	2581	2888	3519	4151	-	-	-	-
	1000	141	96.9	168	-	305	-	507	-	893	-	1294	-	2153	2409	2937	3463	4397	5045	-	-
8.0	1800	225	160	268	324	488	615	809	1014	1425	1773	2067	2570	3436*	3844*	4686*	-	-	-	-	-
	1500	188	134	224	270	407	513	676	847	1190	1481	1726	2148	2871	3212	3915	4618	-	-	-	-
	1200	150	107	179	216	324	410	540	675	950	1182	1377	1714	2291	2563	3123	3684	4678*	-	-	-
	1000	125	89.0	149	180	270	342	450	563	792	984	1148	1428	1908	2136	2603	3070	3897	4472	-	-
9.0	1800	200	143	239	307	434	547	719	901	1266	1576	1837	2285	3054*	3417*	4165*	4912*	-	-	-	-
	1500	167	119	199	256	361	456	601	752	1057	1316	1533	1908	2550	2853	3477	4101	-	-	-	-
	1200	133	95.0	158	204	288	363	478	599	842	1048	1221	1520	2031	2273	2769	3267	4147*	4758*	-	-
	1000	111	79.0	133	170	240	303	399	500	703	874	1019	1268	1695	1896	2311	2726	3461	3971	4860	-
10.0	1800	180	120	201	276	390	492	648	811	1139	1418	1652	2056	2749*	3075*	3749*	4422*	-	-	-	-
	1500	150	100	167	231	324	410	540	675	950	1182	1377	1714	2291	2563	3123	3684	4678*	-	-	-
	1200	120	81.0	134	184	260	327	431	541	760	946	1102	1317	1832	2050	2499	2948	3742	4293*	-	-
	1000	100	66.0	111	153	216	273	359	450	632	787	918	1142	1527	1709	2082	2456	3118	3577	4379	4891
11.2	1800	161	108	182	247	349	440	579	725	1019	1269	1478	1839	2458*	2751*	3353*	3955*	5020*	-	-	-
	1500	134	90.0	151	206	290	366	481	604	849	1056	1230	1531	2046	2290	2791	3292	4179*	4794*	-	-
	1200	107	71.0	120	164	232	292	385	481	677	843	982	1222	1634	1828	2228	2628	3336*	3828*	4685*	-
	1000	89.0	59.0	100	137	193	243	320	401	563	701	817	1017	1359	1521	1853	2186	2775	3183	3896	4353
12.5	1800	144	103	171	207	310	394	518	649	912	1134	1322	1645	2199*	2460*	2999*	3537*	4490*	-	-	-
	1500	120	86.0	143	172	258	327	431	541	760	946	1102	1371	1832	2050	2499	2948	3742	4293*	-	-
	1200	96.0	68.0	114	138	207	262	345	432	608	756	881	1097	1466	1640	1999	2358	2994	3434	4203*	4695*
	1000	80.0	57.0	95.0	115	172	218	288	360	506	630	734	914	1221	1367	1666	1965	2495	2862	3503	3913
14.0	1800	129	92.0	154	186	279	352	464	581	817	1016	1184	1474	1970*	2204*	2687*	3168*	4023*	4616*	-	-
	1500	107	77.0	128	154	232	292	385	481	677	843	982	1222	1634	1828	2228	2628	3336	3828	4685*	-
	1200	86.0	61.0	102	123	186	235	309	388	545	677	789	982	1313	1469	1791	2112	2682	3076	3766*	4206*
	1000	71.0	50.0	85.0	102	153	194	255	319	449	559	652	811	1084	1213	1478	1743	2213	2540	3109	3473
16.0	1800	113	81.0	135	173	245	307	406	509	715	890	1037	1291	1726*	1931*	2353*	2775*	3524*	4042*	4948*	-
	1500	94.0	66.0	112	144	203	255	338	423	595	741	863	1074	1435	1605	1957	2308	2931	3363	4116*	4598*
	1200	75.0	53.0	89.0	115	162	204	269	338	474	591	689	857	1145	1281	1562	1842	2339	2683	3283*	3668*
	1000	63.0	45.0	75.0	96.0	136	171	226	284	399	496	578	719	962	1076	1312	1547	1965	2253	2758	3081
18.0	1800	100	66.0	111	153	202	273	359	450	632	787	918	1142	1527*	1709*	2082*	2456*	3118*	3577*	4379*	4891*
	1500	83.0	55.0	93.0	128	168	226	298	373	525	654	762	948	1267	1418	1728	2038	2588	2969	3634*	4060*
	1200	67.0	45.0	75.0	103	136	183	241	302	424	527	615	765	1023	1144	1395	1645	2089	2397	2934*	3277*
	1000	56.0	37.0	62.0	86.0	113	153	201	252	354	441	514	640	855	957	1166	1375	1746	2003	2452	2739
20.0	1800	90.0	63.0	107	138	183	246	323	405	569	709	826	1028	1374*	1537*	1874*	2210	2806*	3220*	3940*	4402*
	1500	75.0	52.0	89.0	115	152	205	269	338	474	591	689	857	1145	1281	1562	1842	2339	2683	3283*	3668*
	1200	60.0	42.0	71.0	92.0	121	163	215	270	379	472	551	685	916	1025	1250	1474	1871	2146	2627*	2935*
	1000	50.0	35.0	59.0	77.0	101	137	180	224	316	394	459	571	763	854	1040	1228	1559	1788	2189	2445
22.4	1800	80.0	53.0	93.0	115	168	205	283	360	498	630	-	914	-	1367*	-	1965*	-	2862*	-	3913*
	1500	67.0	45.0	78.0	96.0	141	171	237	302	417	527	-	765	-	1144	-	1645	-	2397	-	3277*
	1200	54.0	36.0	62.0	78.0	113	138	191	243	336	425	-	617	-	922	-	1326	-	1932	-	2641*
	1000	45.0	30.0	52.0	64.0	95.0	115	158	202	279	354	-	514	-	768	-	1105	-	1610	-	2201
25.0	1800	72.0	-	-	109	-	184	-	324	-	567	-	822	-	-	-	-	-	-	-	-
	1500	60.0	-	-	91.0	-	153	-	270	-	472	-	685	-	-	-	-	-	-	-	-
	1200	48.0	-	-	72.0	-	122	-	216	-	377	-	548	-	-	-	-	-	-	-	-
	1000	40.0	-	-	60.0	-	102	-	180	-	315	-	457	-	-	-	-	-	-	-	-
28.0	1800	64.0	-	-	95.0	-	170	-	284	-	495	-	-	-	-	-	-	-	-	-	-
	1500	54.0	-	-	80.0	-	144	-	240	-	417	-	-	-	-	-	-	-	-	-	-
	1200	43.0	-	-	63.0	-	114	-	191	-	333	-	-	-	-	-	-	-	-	-	-
	1000	36.0	-	-	53.0	-	96.0	-	159	-	278	-	-	-	-	-	-	-	-	-	-

Yatay redüktörlerde basınçlı yağlama gereklidir.

Forced lubrication required on horizontal gear units

Druckschmierung bei Horizontalgetrieben erforderlich

* Talep edildiğinde yapılan redüktörler.

* Gear units only on request

* Getriebe nur auf Anfrage

TR NÖMİNAL ÇIKIŞ MOMENTLERİ T_{2N} (kNm)

EN NOMINAL OUTPUT TORQUES T_{2N} (kNm)

DE NENN-ABTRIEBSDREHMOMENTE T_{2N} (kNm)

İN	Redüktör Gövdeleri / Gear unit sizes / Getriebegrößen																		
	42	52	62	72	82	92	102	112	122	132	142	152	162	172	182	192	202	212	222
6.3	6.4	10.9	-	20.7	-	34.4	-	60.5	-	87.7	-	146	-	199	-	298	-	-	-
7.1	6.6	11.4	-	20.7	-	34.4	-	60.5	-	87.7	-	146	163	199	235	298	342	418	-
8.0	6.8	11.4	13.8	20.7	26.1	34.4	43.0	60.5	75.3	87.7	109	146	163	199	235	298	342	418	467
9.0	6.8	11.4	14.7	20.7	26.1	34.4	43.0	60.5	75.3	87.7	109	146	163	199	235	298	342	418	467
10.0	6.4	10.7	14.7	20.7	26.1	34.4	43.0	60.5	75.3	87.7	109	146	163	199	235	298	342	418	467
11.2	6.4	10.8	14.7	20.7	26.1	34.4	43.0	60.5	75.3	87.7	109	146	163	199	235	298	342	418	467
12.5	6.8	11.4	13.8	20.6	26.1	34.4	43.0	60.5	75.3	87.7	109	146	163	199	235	298	342	418	467
14.0	6.8	11.4	13.8	20.7	26.1	34.4	43.0	60.5	75.3	87.7	109	146	163	199	235	298	342	418	467
16.0	6.8	11.4	14.7	20.7	26.0	34.4	43.0	60.5	75.3	87.7	109	146	163	199	235	298	342	418	467
18.0	6.4	10.7	14.7	19.4	26.1	34.4	43.0	60.5	75.3	87.7	109	146	163	199	235	298	342	418	467
20.0	6.7	11.4	14.7	19.4	26.1	34.4	43.0	60.5	75.3	87.7	109	146	163	199	235	298	342	418	467
22.4	6.4	11.1	13.8	20.2	24.5	33.8	43.0	59.5	75.3	87.7	109	146	163	199	235	-	342	-	467
25.0	-	-	14.6	-	24.5	-	43.0	-	75.3	-	109	-	-	-	-	-	-	-	-
28.0	-	-	14.2	-	25.5	-	42.4	-	74.0	-	109	-	-	-	-	-	-	-	-

TR TERMAL KAPASİTELER Pt (kW)

EN THERMAL CAPACITIES Pt (kW)

DE WÄRMEGRENZLEISTUNGEN Pt (kW)

iN	Pt (kW)	Redüktör Gövdeleri / Gear unit sizes / Getriebegrößen																	n ₁ =1000 min ⁻¹			
		42	52	62	72	82	92	102	112	122	132	142	152	162	172	182	192	202	212	222		
6.3	Pt1	52.2	67.8	-	92.1	-	118	-	137	-	*	-	*	-	*	-	*	-	*	-		
	Pt2	108	146	-	225	-	299	-	459	-	591	-	574	-	638	-	*	-	*	-		
	Pt3	122	194	-	311	-	485	-	710	-	1225	-	1463	-	1771	-	*	-	*	-		
	Pt4	165	261	-	425	-	639	-	970	-	1584	-	1818	-	2285	-	*	-	*	-		
7.1	Pt1	57.2	70.4	-	91.6	-	119	-	148	-	*	-	*	-	*	-	*	-	*	-		
	Pt2	111	149	-	218	-	292	-	463	-	600	-	603	601	697	672	*	*	*	*		
	Pt3	123	193	-	293	-	456	-	691	-	1186	-	1420	1477	1723	1772	*	*	*	*		
	Pt4	168	261	-	402	-	601	-	950	-	1540	-	1781	1846	2230	2305	*	*	*	*		
8.0	Pt1	55.5	69.7	76.0	90.9	101	120	122	155	164	*	*	*	*	*	*	*	*	*	*		
	Pt2	106	145	160	212	240	285	296	458	519	603	669	625	632	748	733	*	*	*	*		
	Pt3	117	186	201	277	318	434	481	659	902	1132	1288	1375	1435	1682	1727	*	*	*	*		
	Pt4	158	250	271	384	437	573	630	913	1193	1484	1691	1730	1807	2197	2247	*	*	*	*		
9.0	Pt1	54.5	69.3	79.7	91.1	102	122	126	163	186	199	216	*	*	*	*	*	*	*	*		
	Pt2	103	142	162	206	233	277	289	446	530	606	685	648	668	802	805	*	*	*	*		
	Pt3	111	177	201	264	300	411	451	611	878	1076	1248	1318	1393	1643	1695	*	*	*	*		
	Pt4	153	239	271	364	413	547	594	850	1172	1423	1643	1677	1771	2162	2235	*	*	*	*		
10.0	Pt1	52.1	66.7	78.9	90.1	102	121	128	167	197	213	239	204	202	*	*	*	*	*	*		
	Pt2	97.6	134	159	197	226	267	284	432	526	599	686	653	681	828	847	*	*	*	*		
	Pt3	104	163	193	248	286	386	430	575	837	1019	1190	1248	1329	1579	1643	*	*	*	*		
	Pt4	142	221	260	344	394	515	567	802	1128	1353	1582	1602	1707	2094	2186	*	*	*	*		
11.2	Pt1	50.3	64.7	77.5	92.5	101	118	126	176	199	231	252	222	226	234	227	*	*	*	*		
	Pt2	93.5	129	154	200	218	254	275	439	505	613	678	645	682	831	864	*	*	*	*		
	Pt3	98.9	154	184	246	269	360	406	571	771	1006	1135	1171	1262	1497	1584	*	*	*	*		
	Pt4	135	209	250	343	374	482	539	800	1040	1345	1512	1515	1626	1997	2111	*	*	*	*		
12.5	Pt1	48.8	64.3	73.7	92.0	97.5	118	124	182	198	231	257	240	240	265	255	307	295	*	*		
	Pt2	89.4	125	145	195	209	249	264	434	485	583	661	650	669	850	861	*	*	*	*		
	Pt3	95.5	152	168	241	255	349	383	560	724	924	1067	1151	1187	1459	1499	*	*	*	*		
	Pt4	129	205	231	334	353	464	508	781	979	1236	1429	1488	1536	1952	2004	*	*	*	*		
14.0	Pt1	46.4	61.2	71.2	85.5	99.7	116	121	176	206	230	271	245	257	279	287	335	340	*	*		
	Pt2	84.6	118	138	179	211	241	252	411	493	558	672	626	672	830	877	*	*	*	*		
	Pt3	89.3	141	159	215	253	328	356	519	719	857	1058	1070	1161	1366	1460	*	*	*	*		
	Pt4	120	190	217	300	352	441	474	725	977	1154	1420	1392	1512	1838	1959	*	*	*	*		
16.0	Pt1	42.6	57.7	70.3	80.6	98.9	110	119	169	210	216	268	257	259	286	298	348	361	343	*		
	Pt2	77.2	110	134	166	205	225	245	385	486	511	639	629	647	798	854	*	*	*	*		
	Pt3	80.4	129	157	198	247	301	346	473	702	759	966	1048	1080	1270	1368	*	*	*	*		
	Pt4	109	174	212	274	343	405	458	663	951	1027	1302	1368	1409	1714	1846	*	*	*	*		
18.0	Pt1	40.9	55.5	67.0	77.6	91.5	105	116	159	204	223	264	253	273	298	305	369	375	374	359		
	Pt2	73.5	105	126	160	188	212	236	359	459	516	610	595	651	783	821	*	*	*	*		
	Pt3	75.6	121	145	189	221	282	325	441	648	762	899	966	1058	1213	1268	*	*	*	*		
	Pt4	102	165	198	262	307	378	434	621	881	1029	1213	1269	1386	1638	1723	*	*	*	*		
20.0	Pt1	40.1	52.1	62.9	72.7	86.9	102	111	155	193	212	244	247	263	299	310	368	386	380	379		
	Pt2	71.6	98.7	117	148	175	204	221	346	427	482	554	565	611	766	803	*	*	*	*		
	Pt3	73.1	113	134	172	203	269	299	416	589	695	796	888	976	1163	1205	*	*	*	*		
	Pt4	99.3	153	183	241	282	362	400	587	802	941	1077	1165	1282	1577	1634	*	*	*	*		
22.4	Pt1	37.1	48.5	60.2	70.1	82.7	94	104	145	179	-	246	-	253	-	306	-	376	-	369		
	Pt2	66.2	91.2	113	142	168	189	207	320	398	-	555	-	577	-	779	-	*	-	*		
	Pt3	66.6	103	126	164	194	243	278	378	551	-	796	-	895	-	1156	-	*	-	*		
	Pt4	90.7	140	172	228	268	326	373	534	751	-	1078	-	1176	-	1568	-	*	-	*		
25.0	Pt1	-	-	56.4	-	77.3	-	101	-	173	-	232	-	-	-	-	-	-	-	-		
	Pt2	-	-	105	-	155	-	200	-	381	-	516	-	-	-	-	-	-	-	-		
	Pt3	-	-	116	-	177	-	267	-	516	-	727	-	-	-	-	-	-	-	-		
	Pt4	-	-	159	-	247	-	357	-	706	-	984	-	-	-	-	-	-	-	-		
28.0	Pt1	-	-	52.5	-	74.8	-	94	-	163	-	-	-	-	-	-	-	-	-	-		
	Pt2	-	-	97.7	-	149	-	186	-	354	-	-	-	-	-	-	-	-	-	-		
	Pt3	-	-	106	-	169	-	241	-	468	-	-	-	-	-	-	-	-	-	-		
	Pt4	-	-	145	-	235	-	324	-	643	-	-	-	-	-	-	-	-	-	-		

* Talep edildiğinde

- A) Değerler aşağıda belirtilen şartlar için geçerlidir:
Saatlik çalışma döngüsü: %100
Büyük bir alanda kurulum rakım 1000 m'ye kadar
- B) Değerler aşağıda belirtilen şartlar için geçerlidir:
Soğutma suyu, çıkış su sıcaklığı ne olursa olsun, soğuk su giriş sıcaklığı 20°C olmalıdır.
Soğutma suyu çıkış sıcaklığının sınırlanmasına ilişkin hesaplama, ancak talep edildiğinde sağlanır.

* On request

- A) Values refer to:
Operating cycle: 100%
Installation in a large hall Altitude up to 1000 m
- B) Values refer to:
A cooling water inlet temperature of 20°C with unlimited cooling water outlet temperature.
A recalculation with a limited cooling water outlet temperature is possible on request.

* Auf Anfrage

- A) Werte gelten für:
Einschaltdauer: 100%
Aufstellung in großer Halle Höhenlage bis 1000 m
- B) Werte gelten für:
Eine Kühlwassereintrittstemperatur von 20°C ohne Begrenzung der Kühlwassertemperatur.
Die Nachrechnung mit Begrenzung der Kühlwasser austrittstemperatur ist auf Anfrage möglich.

Pt1 Redüktörler, ilave soğutucusu yok. A

Pt2 Redüktörler, fan soğutuculu. A

Pt3 Redüktörler, monte edilmiş serpantinli soğutucu. A,B

Pt4 Redüktörler, fanlı ve monte edilmiş serpantinli soğutucu. A,B

Pt1 Gear units without auxiliary cooling A

Pt2 Gear units with fan A

Pt3 Gear units with built-in cooling coil A,B

Pt4 Gear units with fan and built-in cooling coil A,B

Pt1 Getriebe ohne Zusatzkühlung A

Pt2 Getriebe mit Lüfterkühlung A

Pt3 Getriebe mit eingebauter Kühlschlange A,B

Pt4 Getriebe mit Lüfter und eingebauter Kühlschlange A,B

TR TERMAL KAPASİTELER Pt (kW)

EN THERMAL CAPACITIES Pt (kW)

DE WÄRMEGRENZLEISTUNGEN Pt (kW)

İN	Pt (kW)	Redüktör Gövdeleri / Gear unit sizes / Getriebegrößen																n ₁ =1500 min ⁻¹					
		42	52	62	72	82	92	102	112	122	132	142	152	162	172	182	192	202	212	222			
6.3	Pt1	49.5	49.8	-	*	-	*	-	*	-	*	-	*	-	*	-	*	-	*	-			
	Pt2	135	175	-	261	-	328	-	437	-	451	-	*	-	*	-	*	-	*	-			
	Pt3	149	231	-	364	-	553	-	761	-	1221	-	1292	-	1438	-	*	-	*	-			
	Pt4	214	334	-	536	-	789	-	1146	-	1774	-	1860	-	2194	-	*	-	*	-			
7.1	Pt1	52.6	55.0	-	*	-	*	-	*	-	*	-	*	-	*	-	*	-	*	-			
	Pt2	140	181	-	257	-	329	-	462	-	503	-	345	-	*	-	*	-	*	-			
	Pt3	151	231	-	345	-	526	-	755	-	1217	-	1315	-	1331	-	1487	-	1472	-			
	Pt4	218	334	-	509	-	750	-	1139	-	1763	-	1888	-	1918	-	2243	-	2253	-			
8.0	Pt1	52.4	57.5	60.4	66.2	*	*	*	*	*	*	*	*	*	*	*	*	*	*	*			
	Pt2	135	179	195	254	282	328	335	478	511	548	592	430	398	*	*	*	*	*	*			
	Pt3	143	223	241	329	374	506	556	734	980	1194	1345	1332	1359	1537	1530	*	*	*	*			
	Pt4	206	322	348	489	553	721	787	1110	1425	1734	1961	1897	1948	2306	2305	*	*	*	*			
9.0	Pt1	53.4	61.7	69.2	74.7	78.7	88.0	*	*	*	*	*	*	*	*	*	*	*	*	*			
	Pt2	132	177	202	253	281	330	340	494	564	612	679	552	541	596	553	*	*	*	*			
	Pt3	138	215	243	317	359	487	531	700	987	1182	1362	1359	1414	1625	1640	*	*	*	*			
	Pt4	200	309	351	467	528	696	751	1054	1433	1713	1966	1927	2009	2407	2448	*	*	*	*			
10.0	Pt1	52.4	62.3	72.3	79.3	85.9	97.9	97.2	*	*	*	*	*	*	*	*	*	*	*	*			
	Pt2	125	168	200	246	278	326	342	499	589	644	729	624	629	724	705	*	*	*	*			
	Pt3	129	200	235	301	345	462	513	670	962	1151	1335	1342	1411	1643	1682	*	*	*	*			
	Pt4	186	288	338	445	508	661	724	1007	1403	1661	1934	1898	2003	2421	2496	*	*	*	*			
11.2	Pt1	51.4	62.4	73.6	85.1	89.8	102	105	121	*	*	*	*	*	*	*	*	*	*	*			
	Pt2	120	163	195	251	272	315	338	519	583	687	753	661	682	800	803	*	*	*	*			
	Pt3	122	189	225	300	327	436	489	675	900	1158	1299	1294	1381	1614	1684	*	*	*	*			
	Pt4	177	273	325	445	485	622	693	1015	1309	1675	1875	1832	1951	2369	2480	*	*	*	*			
12.5	Pt1	50.5	63.3	71.9	87.3	90.1	106	108	138	*	*	*	*	*	*	*	*	*	*	*			
	Pt2	115	160	185	247	263	311	328	522	573	673	757	699	705	868	857	*	*	*	*			
	Pt3	118	187	208	295	311	423	463	668	854	1077	1239	1297	1328	1611	1637	*	*	*	*			
	Pt4	169	268	301	434	459	601	657	998	1242	1553	1790	1826	1873	2357	2402	*	*	*	*			
14.0	Pt1	48.6	61.6	70.9	83.3	95.1	108	110	145	156	*	*	*	*	*	*	*	*	*	*			
	Pt2	110	153	177	228	268	304	316	504	595	660	789	700	741	893	924	*	*	*	*			
	Pt3	110	174	197	264	310	401	434	623	858	1011	1244	1229	1324	1541	1632	*	*	*	*			
	Pt4	158	248	285	392	458	573	615	932	1247	1463	1796	1731	1869	2255	2389	*	*	*	*			
16.0	Pt1	45.0	59.0	71.2	80.2	96.8	106	112	147	172	163	197	*	*	*	*	*	*	*	*			
	Pt2	101	143	172	214	262	287	309	478	595	615	766	724	735	890	937	*	*	*	*			
	Pt3	100	160	195	244	303	369	422	572	844	905	1148	1220	1251	1458	1559	*	*	*	*			
	Pt4	144	230	278	359	447	528	596	856	1221	1312	1659	1718	1761	2130	2281	*	*	*	*			
18.0	Pt1	43.6	57.5	69.0	78.8	91.6	103	113	146	179	185	213	173	*	*	*	*	*	*	*			
	Pt2	96.3	137	165	206	242	271	302	452	571	633	746	704	763	906	937	*	*	*	*			
	Pt3	94.2	151	181	234	273	346	400	538	784	917	1078	1141	1243	1415	1471	*	*	*	*			
	Pt4	135	217	260	345	403	496	566	806	1137	1323	1557	1610	1752	2060	2156	*	*	*	*			
20.0	Pt1	42.8	54.4	65.3	74.6	88.0	102	109	145	173	183	206	183	186	*	*	*	*	*	*			
	Pt2	93.9	129	153	192	226	262	284	437	536	598	683	678	726	900	933	*	*	*	*			
	Pt3	91.2	141	165	213	252	333	369	509	716	839	960	1057	1156	1369	1410	*	*	*	*			
	Pt4	131	202	240	316	370	474	522	762	1039	1215	1387	1484	1629	1995	2059	*	*	*	*			
22.4	Pt1	39.7	50.7	62.5	72.1	84.0	94	103	136	162	-	210	-	183	-	*	-	*	-	*			
	Pt2	86.9	118	147	185	217	244	266	405	499	-	686	-	690	-	911	-	*	-	*			
	Pt3	83.1	128	158	204	240	299	344	463	670	-	961	-	1062	-	1356	-	*	-	*			
	Pt4	119	185	227	301	353	428	488	696	973	-	1389	-	1496	-	1978	-	*	-	*			
25.0	Pt1	-	-	58.8	-	78.7	-	101	-	158	-	199	-	-	-	-	-	-	-	-			
	Pt2	-	-	137	-	201	-	257	-	479	-	640	-	-	-	-	-	-	-	-			
	Pt3	-	-	145	-	220	-	329	-	629	-	879	-	-	-	-	-	-	-	-			
	Pt4	-	-	210	-	324	-	467	-	916	-	1270	-	-	-	-	-	-	-	-			
28.0	Pt1	-	-	55.2	-	77.0	-	95.3	-	153	-	-	-	-	-	-	-	-	-	-			
	Pt2	-	-	128	-	194	-	240	-	448	-	-	-	-	-	-	-	-	-	-			
	Pt3	-	-	133	-	210	-	298	-	573	-	-	-	-	-	-	-	-	-	-			
	Pt4	-	-	191	-	308	-	425	-	835	-	-	-	-	-	-	-	-	-	-			

[*] Talep edildiğinde

A) Değerler aşağıda belirtilen şartlar için geçerlidir:

Saatlik çalışma döngüsü: %100

Büyük bir alanda kurulum rakım 1000 m'ye kadar

B) Değerler aşağıda belirtilen şartlar için geçerlidir:

Soğutma suyu, çıkış su sıcaklığı ne olursa olsun, soğuk su giriş sıcaklığı 20°C olmalıdır.

Soğutma suyu çıkış sıcaklığının sınırlanmasına ilişkin hesaplama, ancak talep edildiğinde sağlanır.

[*] On request

A) Values refer to:

Operating cycle: 100%

Installation in a large hall Altitude up to 1000 m

B) Values refer to:

A cooling water inlet temperature of 20°C with unlimited cooling water outlet temperature.

A recalculation with a limited cooling water outlet temperature is possible on request.

[*] Auf Anfrage

A) Werte gelten für:

Einschaltdauer: 100%

Aufstellung in großer Halle Höhenlage bis 1000 m

B) Werte gelten für:

Eine Kühlwassereintrittstemperatur von 20°C ohne Begrenzung der Kühlwasseraustrittstemperatur.

Die Nachrechnung mit Begrenzung der Kühlwasseraustrittstemperatur ist auf Anfrage möglich.

Pt1 Redüktörler, ilave soğutucusu yok. A

Pt2 Redüktörler, fan soğutucu. A

Pt3 Redüktörler, monte edilmiş serpantinli soğutucu. A,B

Pt4 Redüktörler, fanlı ve monte edilmiş serpantinli soğutucu. A,B

Pt1 Gear units without auxiliary cooling A

Pt2 Gear units with fan A

Pt3 Gear units with built-in cooling coil A,B

Pt4 Gear units with fan and built-in cooling coil A,B

Pt1 Getriebe ohne Zusatzkühlung A

Pt2 Getriebe mit Lüfterkühlung A

Pt3 Getriebe mit eingebauter Kühlschlange A,B

Pt4 Getriebe mit Lüfter und eingebauter Kühlschlange A,B

TR TERMAL KAPASİTELER Pt (kW)

EN THERMAL CAPACITIES Pt (kW)

DE WÄRMEGRENZLEISTUNGEN Pt (kW)

İN	Pt (kW)	Redüktör Gövdeleri / Gear unit sizes / Getriebegrößen																n ₁ =1800 min ⁻¹			
		42	52	62	72	82	92	102	112	122	132	142	152	162	172	182	192	202	212	222	
6.3	Pt1	41.4	*	-	*	-	*	-	*	-	*	-	*	-	*	-	*	-	*	-	
	Pt2	147	185	-	268	-	325	-	373	-	*	-	*	-	*	-	*	-	*	-	
	Pt3	160	244	-	380	-	569	-	747	-	1124	-	1048	-	1040	-	*	-	*	-	
	Pt4	241	368	-	585	-	849	-	1177	-	1712	-	1593	-	1694	-	*	-	*	-	
7.1	Pt1	45.5	*	-	*	-	*	-	*	-	*	-	*	-	*	-	*	-	*	-	
	Pt2	153	193	-	267	-	332	-	416	-	364	-	*	-	*	-	*	-	*	-	
	Pt3	162	246	-	362	-	547	-	753	-	1150	-	1124	1103	1170	1102	*	*	*	*	
	Pt4	245	370	-	559	-	813	-	1186	-	1744	-	1699	1677	1869	1794	*	*	*	*	
8.0	Pt1	46.6	*	*	*	*	*	*	*	*	*	*	*	*	*	*	*	*	*	*	
	Pt2	148	192	208	267	293	337	339	450	453	445	462	*	*	*	*	*	*	*		
	Pt3	155	239	256	349	394	529	578	743	973	1157	1291	1192	1188	1294	1243	*	*	*	*	
	Pt4	233	359	387	540	607	787	854	1172	1478	1756	1970	1784	1792	2046	1980	*	*	*	*	
9.0	Pt1	49.3	51.5	55.8	*	*	*	*	*	*	*	*	*	*	*	*	*	*	*	*	
	Pt2	146	193	218	271	299	348	354	491	541	558	607	410	370	*	*	*	*	*		
	Pt3	149	232	261	339	381	515	559	721	1005	1183	1354	1290	1322	1484	1467	*	*	*	*	
	Pt4	225	347	392	520	585	768	825	1135	1524	1790	2043	1915	1969	2307	2299	*	*	*	*	
10.0	Pt1	49.5	54.8	62.2	65.0	66.5	*	*	*	*	*	*	*	*	*	*	*	*	*	*	
	Pt2	139	185	218	266	300	349	362	511	589	623	697	537	520	558	505	*	*	*	*	
	Pt3	140	215	253	323	368	493	545	701	995	1175	1358	1320	1372	1572	1586	*	*	*	*	
	Pt4	211	324	379	499	566	734	803	1099	1515	1771	2053	1951	2039	2426	2466	*	*	*	*	
11.2	Pt1	49.3	56.7	65.9	73.5	74.7	81.0	*	*	*	*	*	*	*	*	*	*	*	*	*	
	Pt2	135	181	214	274	296	340	362	544	599	689	748	612	616	693	668	*	*	*	*	
	Pt3	133	204	244	323	352	466	522	712	941	1199	1340	1302	1377	1589	1641	*	*	*	*	
	Pt4	201	309	366	500	544	696	771	1117	1429	1811	2020	1924	2034	2441	2528	*	*	*	*	
12.5	Pt1	48.9	58.9	65.9	78.0	78.1	89.3	88.2	*	*	*	*	*	*	*	*	*	*	*	*	
	Pt2	130	177	204	271	288	339	355	554	599	691	771	675	669	802	769	*	*	*	*	
	Pt3	129	203	225	319	336	456	497	709	901	1127	1292	1324	1347	1617	1630	*	*	*	*	
	Pt4	193	303	340	490	516	674	734	1105	1367	1695	1948	1946	1984	2475	2500	*	*	*	*	
14.0	Pt1	47.4	58.1	66.3	76.5	85.4	95.6	94.6	*	*	*	*	*	*	*	*	*	*	*	*	
	Pt2	122	169	197	252	295	333	345	541	630	690	821	700	731	863	878	*	*	*	*	
	Pt3	120	190	213	287	336	432	467	666	910	1066	1310	1271	1363	1574	1655	*	*	*	*	
	Pt4	181	282	322	443	517	645	691	1038	1382	1610	1972	1869	2008	2405	2532	*	*	*	*	
16.0	Pt1	44.4	56.5	67.7	75.1	89.0	96.1	100	118	*	*	*	*	*	*	*	*	*	*	*	
	Pt2	112	158	192	237	289	315	340	517	638	652	808	742	746	889	923	*	*	*	*	
	Pt3	109	174	211	265	328	400	457	614	900	960	1216	1274	1301	1507	1602	*	*	*	*	
	Pt4	163	261	316	407	506	596	671	958	1360	1452	1833	1873	1913	2298	2449	*	*	*	*	
18.0	Pt1	43.1	55.8	66.5	75.2	86.2	96.4	104	124	145	*	*	*	*	*	*	*	*	*	*	
	Pt2	107	153	184	230	268	301	333	493	618	680	798	736	793	930	953	*	*	*	*	
	Pt3	103	164	196	254	298	375	432	578	842	979	1150	1204	1308	1480	1533	*	*	*	*	
	Pt4	154	247	296	391	456	561	640	905	1274	1475	1732	1771	1923	2250	2345	*	*	*	*	
20.0	Pt1	42.6	53.1	63.4	71.6	83.6	96.3	102	128	147	145	160	*	*	*	*	*	*	*	*	
	Pt2	105	143	171	214	251	291	314	478	582	646	736	716	763	936	963	*	*	*	*	
	Pt3	99.8	153	181	233	273	361	400	550	770	900	1027	1120	1221	1440	1478	*	*	*	*	
	Pt4	149	230	273	359	419	538	592	859	1166	1358	1549	1641	1796	2191	2253	*	*	*	*	
22.4	Pt1	39.5	49.6	60.8	69.4	80.1	89.0	96.6	120	138	-	165	-	*	-	*	-	*	-		
	Pt2	97.5	133	164	206	242	270	295	445	544	-	741	-	726	-	942	-	*	-		
	Pt3	90.9	139	172	222	261	325	373	501	722	-	1029	-	1123	-	1423	-	*	-		
	Pt4	136	209	258	342	400	486	552	783	1092	-	1552	-	1651	-	2168	-	*	-		
25.0	Pt1	-	-	57.2	-	75.3	-	94.4	-	136	-	159	-	-	-	-	-	-	-		
	Pt2	-	-	153	-	223	-	286	-	523	-	692	-	-	-	-	-	-	-		
	Pt3	-	-	157	-	240	-	358	-	678	-	942	-	-	-	-	-	-	-		
	Pt4	-	-	239	-	367	-	529	-	1029	-	1420	-	-	-	-	-	-	-		
28.0	Pt1	-	-	54.1	-	74.3	-	90.3	-	136	-	-	-	-	-	-	-	-	-		
	Pt2	-	-	142	-	216	-	266	-	492	-	-	-	-	-	-	-	-	-		
	Pt3	-	-	145	-	228	-	324	-	618	-	-	-	-	-	-	-	-	-		
	Pt4	-	-	217	-	351	-	482	-	941	-	-	-	-	-	-	-	-	-		

☒ Talep edildiğinde

- A)** Değerler aşağıda belirtilen şartlar için geçerlidir:
Saatlik çalışma döngüsü: %100
Büyük bir alanda kurulum rakım 1000 m'ye kadar
- B)** Değerler aşağıda belirtilen şartlar için geçerlidir:
Soğutma suyu, çıkış su sıcaklığı ne olursa olsun, soğuk su giriş sıcaklığı 20°C olmalıdır.
Soğutma suyu çıkış sıcaklığının sınırlandırılmasına ilişkin hesaplama, ancak talep edildiğinde sağlanır.

☒ On request

- A)** Values refer to:
Operating cycle: 100%
Installation in a large hall Altitude up to 1000 m
- B)** Values refer to:
A cooling water inlet temperature of 20°C with unlimited cooling water outlet temperature.
A recalculation with a limited cooling water outlet temperature is possible on request.

☒ Auf Anfrage

- A)** Werte gelten für:
Einschaltdauer: 100%
Aufstellung in großer Halle Höhenlage bis 1000 m
- B)** Werte gelten für:
Eine Kühlwassereintrittstemperatur von 20°C ohne Begrenzung der Kühlwassertemperatur.
Die Nachrechnung mit Begrenzung der Kühlwasser austrittstemperatur ist auf Anfrage möglich.

Pt1 Redüktörler, ilave soğutucusu yok. **A**

Pt2 Redüktörler, fan soğutuculu. **A**

Pt3 Redüktörler, monte edilmiş serpantinli soğutucu. **A,B**

Pt4 Redüktörler, fanlı ve monte edilmiş serpantinli soğutucu. **A,B**

Pt1 Gear units without auxiliary cooling **A**

Pt2 Gear units with fan **A**

Pt3 Gear units with built-in cooling coil **A,B**

Pt4 Gear units with fan and built-in cooling coil **A,B**

Pt1 Getriebe ohne Zusatzkühlung **A**

Pt2 Getriebe mit Lüfterkühlung **A**

Pt3 Getriebe mit eingebauter Kühlschlange **A,B**

Pt4 Getriebe mit Lüfter und eingebauter Kühlschlange **A,B**

TR NÖMİNAL GÜÇ DEĞERLERİ P_{2N} (kW)EN NOMINAL POWER RATINGS P_{2N} (kW)DE NENNLEISTUNGEN P_{2N} (kW)

iN	n1 min ⁻¹	n2 min ⁻¹	Redüktör Gövdeleri / Gear unit sizes / Getriebegrößen																	
			53	63	73	83	93	103	113	123	133	143	153	163	173	183	193	203	213	223
22.4	1800	80.0	-	-	-	-	-	-	-	-	752	-	1307	-	1709	-	2563*	-	3588*	-
	1500	67.0	-	-	-	-	-	-	-	-	629	-	1094	-	1431	-	2146	-	3005	-
	1200	54.0	-	-	-	-	-	-	-	-	507	-	882	-	1153	-	1730	-	2421	-
	1000	45.0	-	-	-	-	-	-	-	-	422	-	734	-	961	-	1441	-	2019	-
25.0	1800	72.0	89.0	-	166	-	274	-	488	-	676	-	1176	1330	1537	1845	2306*	2653*	3229*	3614*
	1500	60.0	73.0	-	139	-	228	-	406	-	563	-	980	1108	1281	1537	1922	2210	2691	3011
	1200	48.0	59.0	-	111	-	183	-	325	-	451	-	784	886	1025	1230	1537	1769	2152	2409
	1000	40.0	49.0	-	92.0	-	152	-	270	-	375	-	653	738	854	1025	1281	1474	1794	2007
28.0	1800	64.0	79.0	-	148	-	244	-	434	-	601	745	1046	1182	1367	1640	2050*	2358*	2870*	3212*
	1500	54.0	66.0	-	124	-	205	-	366	-	507	628	882	998	1153	1384	1730	1989	2421	2710
	1200	43.0	53.0	-	99.0	-	163	-	291	-	404	500	702	794	918	1102	1377	1584	1929	2158
	1000	36.0	44.0	-	83.0	-	137	-	244	-	338	418	588	665	768	922	1153	1326	1615	1806
31.5	1800	57.0	70.0	94.0	132	165	217	266	387	469	536	663	931	1053	1217	1461	1826*	2100*	2556*	2861*
	1500	48.0	59.0	79.0	111	139	183	224	325	396	451	558	784	886	1025	1230	1537	1769	2152	2409
	1200	38.0	47.0	62.0	88.0	110	145	177	257	313	357	442	620	702	811	973	1217	1399	1704	1907
	1000	32.0	39.0	52.0	73.0	93.0	121	149	216	263	300	372	522	591	683	820	1025	1179	1435	1605
35.5	1800	51.0	62.0	84.0	117	148	194	238	346	420	478	594	833	941	1089	1307	1684*	1879*	2287*	2559*
	1500	42.0	52.0	69.0	97.0	121	160	196	285	346	395	489	685	775	897	1076	1345	1547	1884	2108
	1200	34.0	42.0	56.0	79.0	98.0	130	158	231	279	319	396	555	627	726	871	1089	1253	1525	1706
	1000	28.0	35.0	46.0	64.0	81.0	106	131	190	231	263	325	457	517	598	717	897	1031	1256	1406
40.0	1800	45.0	55.0	75.0	104	131	171	210	305	370	422	523	734	831	961	1153	1441*	1658*	2019*	2258*
	1500	38.0	47.0	62.0	88.0	110	145	177	257	313	357	442	620	702	811	973	1217	1399	1704	1907
	1200	30.0	37.0	49.0	69.0	87.0	114	140	203	247	282	349	490	554	641	768	961	1105	1345	1506
	1000	25.0	31.0	41.0	57.0	72.0	95.0	116	169	206	235	291	408	461	533	641	801	921	1121	1255
45.0	1800	40.0	49.0	65.0	92.0	115	152	187	270	329	375	465	653	738	854	1025	1281*	1474*	1794*	2007*
	1500	33.0	41.0	54.0	76.0	95.0	125	154	223	271	310	384	539	609	705	846	1057	1216	1480	1656
	1200	27.0	33.0	44.0	62.0	78.0	102	125	183	222	253	314	441	499	576	692	865	995	1211	1355
	1000	22.0	27.0	36.0	50.0	63.0	84.0	102	149	181	206	256	359	406	469	563	705	810	986	1104
50.0	1800	36.0	44.0	59.0	83.0	104	137	168	244	297	338	418	588	665	768	922	1153	1326*	1615*	1806*
	1500	30.0	37.0	49.0	69.0	87.0	114	140	203	247	282	349	490	554	641	768	961	1105	1345	1506
	1200	24.0	30.0	39.0	55.0	69.0	91.0	112	162	198	225	278	392	443	512	615	768	884	1076	1205
	1000	20.0	24.0	33.0	46.0	57.0	76.0	93.0	135	164	188	233	326	369	426	512	641	736	897	1004
56.0	1800	32.0	39.0	52.0	73.0	93.0	121	149	216	263	300	372	522	591	683	820	1025	1179	1435*	1605*
	1500	27.0	33.0	44.0	62.0	78.0	102	125	183	222	253	314	441	499	576	692	865	995	1211	1355
	1200	21.0	26.0	35.0	48.0	60.0	80.0	98.0	142	172	197	244	343	388	448	538	672	773	941	1054
	1000	18.0	21.0	30.0	41.0	51.0	67.0	84.0	121	147	167	208	292	330	381	458	573	659	803	898
63.0	1800	29.0	36.0	48.0	66.0	84.0	110	136	196	239	272	337	473	536	619	743	928	1068	1301*	1456*
	1500	24.0	30.0	39.0	55.0	69.0	91.0	112	162	198	225	278	392	443	512	615	768	884	1076	1205
	1200	19.0	24.0	31.0	44.0	55.0	72.0	89.0	129	156	179	220	310	351	405	487	608	700	852	954
	1000	16.0	19.0	26.0	37.0	46.0	60.0	73.0	107	131	149	185	259	294	339	407	509	585	713	798
71.0	1800	25.0	31.0	41.0	57.0	72.0	95.0	116	169	206	235	291	408	461	533	641	801	921	1121*	1255*
	1500	21.0	26.0	35.0	48.0	60.0	80.0	98.0	142	172	197	244	343	388	448	538	672	773	941	1054
	1200	17.0	20.0	28.0	39.0	49.0	64.0	79.0	114	139	158	196	275	312	360	432	541	622	758	848
	1000	14.0	17.0	22.0	33.0	41.0	53.0	65.0	95.0	115	132	163	230	260	301	361	451	519	632	707
80.0	1800	23.0	28.0	38.0	53.0	66.0	87.0	107	155	189	215	267	375	424	491	590	736	847	1031*	1154*
	1500	19.0	22.0	31.0	43.0	54.0	71.0	88.0	128	154	176	218	307	347	401	481	602	693	843	944
	1200	15.0	18.0	25.0	35.0	43.0	57.0	69.0	101	123	141	174	245	276	320	384	480	552	672	753
	1000	13.0	15.0	20.0	29.0	36.0	47.0	58.0	85.0	103	117	145	204	231	266	320	400	460	560	627
90.0	1800	20.0	25.0	33.0	42.0	57.0	73.0	93.0	135	164	188	233	326	369	426	512	619	736	875*	1004*
	1500	17.0	20.0	28.0	35.0	48.0	61.0	78.0	113	137	156	194	272	308	356	427	517	615	730	837
	1200	13.0	16.0	21.0	28.0	38.0	49.0	61.0	90.0	109	124	154	217	245	284	341	411	490	581	667
	1000	11.0	13.0	18.0	24.0	32.0	41.0	51.0	75.0	91	104	129	181	205	237	284	344	408	486	557
100	1800	18.0	-	28.0	-	52.0	-	84.0	-	148	-	209	-	333	-	434	-	-	-	894*
	1500	15.0	-	22.0	-	43.0	-	69.0	-	123	-	174	-	276	-	361	-	-	-	745
	1200	12.0	-	18.0	-	35.0	-	56.0	-	99	-	139	-	221	-	289	-	-	-	596
	1000	10.0	-	15.0	-	29.0	-	46.0	-	82	-	116	-	185	-	241	-	-	-	496
112	1800	16.0	-	26.0	-	43.0	-	73.0	-	133	-	187	-	-	-	-	-	-	-	-
	1500	13.0	-	21.0	-	36.0	-	61.0	-	110	-	155	-	-	-	-	-	-	-	-
	1200	11.0	-	16.0	-	29.0	-	48.0	-	88	-	124	-	-	-	-	-	-	-	-
	1000	9.0	-	13.0	-	24.0	-	40.0	-	72	-	103	-	-	-	-	-	-	-	-

■ Yatay redüktörlerde basınçlı yağlama gereklidir.

■ Forced lubrication required on horizontal gear units

■ Druckschmierung bei Horizontalgetrieben erforderlich

✳ Talep edildiğinde yapılan redüktörler.

✳ Gear units only on request

✳ Getriebe nur auf Anfrage

TR NÖMİNAL ÇIKIŞ MOMENTLERİ T_{2N} (kNm)

EN NOMINAL OUTPUT TORQUES T_{2N} (kNm)

DE NENN-ABTRIEBSDREHMOMENTE T_{2N} (kNm)

İN	Redüktör Gövdeleri / Gear unit sizes / Getriebegrößen																	
	53	63	73	83	93	103	113	123	133	143	153	163	173	183	193	203	213	223
22.4	-	-	-	-	-	-	-	-	89.8	-	156	-	204	-	306	-	428	-
25.0	11.8	-	22.1	-	36.4	-	64.8	-	89.8	-	156	176	204	245	306	352	428	479
28.0	11.8	-	22.1	-	36.4	-	64.8	-	89.8	111	156	176	204	245	306	352	428	479
31.5	11.8	15.8	22.1	27.7	36.4	44.7	64.8	78.7	89.8	111	156	176	204	245	306	352	428	479
35.5	11.8	15.8	22.1	27.7	36.4	44.7	64.8	78.7	89.8	111	156	176	204	245	306	352	428	479
40.0	11.8	15.8	22.1	27.7	36.4	44.7	64.8	78.7	89.8	111	156	176	204	245	306	352	428	479
45.0	11.8	15.8	22.1	27.7	36.4	44.7	64.8	78.7	89.8	111	156	176	204	245	306	352	428	479
50.0	11.8	15.8	22.1	27.7	36.4	44.7	64.8	78.7	89.8	111	156	176	204	245	306	352	428	479
56.0	11.8	15.8	22.1	27.7	36.4	44.7	64.8	78.7	89.8	111	156	176	204	245	306	352	428	479
63.0	11.8	15.8	22.1	27.7	36.4	44.7	64.8	78.7	89.8	111	156	176	204	245	306	352	428	479
71.0	11.8	15.8	22.1	27.7	36.4	44.7	64.8	78.7	89.8	111	156	176	204	245	306	352	428	479
80.0	11.8	15.8	22.1	27.7	36.4	44.7	64.8	78.7	89.8	111	156	176	204	245	306	352	428	479
90.0	11.8	15.8	20.4	27.7	35.2	44.7	64.8	78.7	89.8	111	156	176	204	245	296	352	418	479
100	-	14.8	-	27.7	-	44.7	-	78.7	-	111	-	176	-	231	-	342	-	474
112	-	15.3	-	25.7	-	43.7	-	78.7	-	111	-	-	-	-	-	-	-	-

TR

TERMAL KAPASİTELER Pt (kW)

EN

THERMAL CAPACITIES Pt (kW)

DE

WÄRMEGRENZLEISTUNGEN Pt (kW)

İN	Pt (kW)	Redüktör Gövdeleri / Gear unit sizes / Getriebegrößen																n ₁ =1000 min ⁻¹			
		53	63	73	83	93	103	113	123	133	143	153	163	173	183	193	203	213	223		
22.4	Pt1	-	-	-	-	-	-	-	-	200	-	263	-	275	-	332	-	357	-		
	Pt2	-	-	-	-	-	-	-	-	309	-	441	-	449	-	*	-	*	-		
	Pt3	-	-	-	-	-	-	-	-	572	-	921	-	921	-	*	-	*	-		
	Pt4	-	-	-	-	-	-	-	-	663	-	1064	-	1050	-	*	-	*	-		
25.0	Pt1	50.9	-	75.0	-	101	-	148	-	195	-	258	270	268	282	329	340	370	350		
	Pt2	74.9	-	112	-	155	-	235	-	300	-	428	452	436	460	*	*	*	*		
	Pt3	107	-	172	-	252	-	427	-	544	-	867	931	868	924	*	*	*	*		
	Pt4	128	-	205	-	299	-	502	-	629	-	1006	1076	991	1054	*	*	*	*		
28.0	Pt1	49.0	-	75.7	-	101	-	145	-	190	218	259	269	270	279	333	345	388	377		
	Pt2	72.1	-	114	-	153	-	226	-	292	334	425	443	434	450	*	*	*	*		
	Pt3	102	-	170	-	244	-	400	-	510	598	836	877	835	871	*	*	*	*		
	Pt4	120	-	204	-	290	-	473	-	595	694	976	1019	961	1001	*	*	*	*		
31.5	Pt1	47.6	55.1	72.8	80.7	98.8	102	141	167	188	215	257	270	268	282	334	348	402	397		
	Pt2	69.9	80.2	109	120	149	154	219	260	285	325	419	441	426	449	*	*	*	*		
	Pt3	97.5	111	161	176	235	292	381	440	490	567	799	846	801	843	*	*	*	*		
	Pt4	116	133	194	210	278	340	452	519	571	660	935	988	924	971	*	*	*	*		
35.5	Pt1	46.1	52.9	70.8	81.3	95.8	102	137	162	184	210	249	269	260	279	332	349	412	412		
	Pt2	67.5	77.1	106	121	145	152	212	251	276	317	403	434	409	442	*	*	*	*		
	Pt3	93.1	105	154	174	223	284	361	411	465	533	740	808	740	805	*	*	*	*		
	Pt4	111	125	187	209	267	330	430	490	545	624	871	953	861	934	*	*	*	*		
40.0	Pt1	43.6	51.4	67.3	78.1	90.7	98.4	132	158	177	205	242	258	252	269	323	343	409	415		
	Pt2	63.5	74.8	101	115	137	148	203	243	266	308	388	414	395	420	*	*	*	*		
	Pt3	86.5	101	144	164	208	270	340	392	440	509	697	749	699	745	*	*	*	*		
	Pt4	103	119	173	198	249	316	405	466	516	598	825	884	815	870	*	*	*	*		
45.0	Pt1	41.6	49.7	64.9	75.8	87.3	95.9	131	152	170	198	242	250	251	259	322	333	401	410		
	Pt2	60.8	72.1	96.9	112	131	144	203	234	255	297	386	398	391	405	*	*	*	*		
	Pt3	81.7	96.3	137	158	197	259	333	371	413	485	682	707	683	703	*	*	*	*		
	Pt4	97.9	115	165	190	237	304	397	443	485	568	809	833	798	820	*	*	*	*		
50.0	Pt1	40.4	47.0	61.3	72.3	85.9	91.2	130	148	169	194	246	254	253	264	326	339	418	418		
	Pt2	58.7	68.0	91.4	106	129	136	199	226	250	289	386	401	389	407	*	*	*	*		
	Pt3	78.8	89.5	129	148	193	241	325	351	402	457	675	692	668	684	*	*	*	*		
	Pt4	94.7	107	155	177	230	283	389	419	474	540	801	821	786	809	*	*	*	*		
56.0	Pt1	38.4	45.2	58.7	69.8	82.0	87.9	120	148	164	187	237	255	245	263	317	339	409	429		
	Pt2	55.6	65.2	86.9	102	122	131	185	225	243	276	368	398	374	402	*	*	*	*		
	Pt3	74.1	84.7	120	141	180	227	295	344	380	429	629	682	626	673	*	*	*	*		
	Pt4	88.4	102	146	169	216	267	352	411	450	509	750	811	737	793	*	*	*	*		
63.0	Pt1	36.2	43.6	54.8	66.0	77.7	86.3	115	146	157	184	226	247	235	255	301	330	401	421		
	Pt2	52.2	62.6	81.0	97.0	114	126	174	220	231	270	350	383	356	386	*	*	*	*		
	Pt3	68.6	81.7	111	132	166	222	273	337	354	418	581	634	578	628	*	*	*	*		
	Pt4	82.2	98.1	133	159	201	262	327	403	419	496	695	761	685	745	*	*	*	*		
71.0	Pt1	35.8	41.3	53.1	62.8	76.1	82.1	112	136	153	177	220	234	225	242	298	309	380	405		
	Pt2	51.6	59.3	78.2	92.2	112	121	169	204	223	260	340	360	341	364	*	*	*	*		
	Pt3	67.8	76.6	106	122	163	208	263	304	338	397	559	589	553	582	*	*	*	*		
	Pt4	81.3	91.7	129	148	195	244	315	364	401	470	668	704	657	690	*	*	*	*		
80.0	Pt1	34.0	39.0	51.9	58.8	72.0	77.6	106	128	148	168	212	226	217	233	283	305	365	385		
	Pt2	48.9	55.6	76.4	85.8	106	113	159	192	217	246	326	349	327	350	*	*	*	*		
	Pt3	63.0	71.1	102	113	151	193	243	283	325	368	527	566	522	557	*	*	*	*		
	Pt4	75.7	85.3	123	137	183	226	292	339	386	438	632	676	620	661	*	*	*	*		
90.0	Pt1	33.6	38.6	49.1	56.8	68.4	75.8	102	125	139	163	200	219	205	223	268	289	356	368		
	Pt2	48.2	55.2	72.1	82.7	101	110	154	187	203	238	307	335	308	336	*	*	*	*		
	Pt3	61.3	70.5	95.0	109	141	189	233	272	299	352	489	534	483	526	*	*	*	*		
	Pt4	73.7	84.5	114	132	169	221	281	327	355	417	584	641	575	626	*	*	*	*		
100	Pt1	-	36.6	-	55.7	-	72.1	-	118	-	159	-	207	-	212	-	277	-	363		
	Pt2	-	52.2	-	81.1	-	105	-	176	-	232	-	316	-	316	-	*	-	*		
	Pt3	-	65.5	-	105	-	175	-	252	-	339	-	494	-	488	-	*	-	*		
	Pt4	-	78.7	-	128	-	206	-	303	-	402	-	593	-	580	-	*	-	*		
112	Pt1	-	36.2	-	52.7	-	68.5	-	114	-	149	-	-	-	-	-	-	-	-		
	Pt2	-	51.7	-	76.7	-	100	-	171	-	217	-	-	-	-	-	-	-	-		
	Pt3	-	63.8	-	97.7	-	162	-	242	-	312	-	-	-	-	-	-	-	-		
	Pt4	-	76.7	-	118	-	192	-	292	-	371	-	-	-	-	-	-	-	-		

* Talep edildiğinde

- A) Değerler aşağıda belirtilen şartlar için geçerlidir:
Saatlik çalışma döngüsü: %100
Büyük bir alanda kurulum rakım 1000 m'ye kadar
- B) Değerler aşağıda belirtilen şartlar için geçerlidir:
Soğutma suyu, çıkış su sıcaklığı ne olursa olsun, soğuk su giriş sıcaklığı 20°C olmalıdır.
Soğutma suyu çıkış sıcaklığının sınırlandırılmasına ilişkin hesaplama, ancak talep edildiğinde sağlanır.

* On request

- A) Values refer to:
Operating cycle: 100%
Installation in a large hall Altitude up to 1000 m
- B) Values refer to:
A cooling water inlet temperature of 20°C with unlimited cooling water outlet temperature.
A recalculation with a limited cooling water outlet temperature is possible on request.

* Auf Anfrage

- A) Werte gelten für:
Einschaltdauer: 100%
Aufstellung in großer Halle Höhenlage bis 1000 m
- B) Werte gelten für:
Eine Kühlwassereintrittstemperatur von 20°C ohne Begrenzung der Kühlwasseraustrittstemperatur.
Die Nachrechnung mit Begrenzung der Kühlwasser austrittstemperatur ist auf Anfrage möglich.

Pt1 Redüktörler, ilave soğutucusu yok. A

Pt2 Redüktörler, fan soğutucusu. A

Pt3 Redüktörler, monte edilmiş serpantinli soğutucu. A,B

Pt4 Redüktörler, fanlı ve monte edilmiş serpantinli soğutucu. A,B

Pt1 Gear units without auxiliary cooling A

Pt2 Gear units with fan A

Pt3 Gear units with built-in cooling coil A,B

Pt4 Gear units with fan and built-in cooling coil A,B

Pt1 Getriebe ohne Zusatzkühlung A

Pt2 Getriebe mit Lüfterkühlung A

Pt3 Getriebe mit eingebauter Kühlschlange A,B

Pt4 Getriebe mit Lüfter und eingebauter Kühlschlange A,B

TR TERMAL KAPASİTELER Pt (kW)

EN THERMAL CAPACITIES Pt (kW)

DE WÄRMEGRENZLEISTUNGEN Pt (kW)

İN	Pt (kW)	Redüktör Gövdeleri / Gear unit sizes / Getriebegrößen																n ₁ =1200 min ⁻¹			
		53	63	73	83	93	103	113	123	133	143	153	163	173	183	193	203	213	223		
22.4	Pt1	-	-	-	-	-	-	-	-	176	-	213	-	210	-	237	-	*	-		
	Pt2	-	-	-	-	-	-	-	-	301	-	401	-	390	-	*	-	*	-		
	Pt3	-	-	-	-	-	-	-	-	592	-	931	-	919	-	*	-	*	-		
	Pt4	-	-	-	-	-	-	-	-	695	-	1080	-	1043	-	*	-	*	-		
25.0	Pt1	50.8	-	74.1	-	98.5	-	139	-	173	-	211	216	207	211	239	240	*	*		
	Pt2	80.7	-	120	-	163	-	240	-	294	-	393	407	383	394	*	*	*	*		
	Pt3	115	-	184	-	267	-	448	-	563	-	879	939	869	918	*	*	*	*		
	Pt4	141	-	225	-	325	-	538	-	660	-	1024	1087	989	1041	*	*	*	*		
28.0	Pt1	49.1	-	75.2	-	99.0	-	137	-	173	197	220	225	219	221	257	260	*	*		
	Pt2	78.0	-	122	-	162	-	234	-	291	330	402	412	395	402	*	*	*	*		
	Pt3	108	-	183	-	260	-	421	-	531	621	856	893	845	876	*	*	*	*		
	Pt4	134	-	225	-	317	-	510	-	629	732	1007	1044	975	1007	*	*	*	*		
31.5	Pt1	48.0	55.3	72.7	80.2	97.7	100	135	159	174	198	226	235	227	235	272	279	282	*		
	Pt2	75.9	87.0	117	130	160	164	230	268	289	328	407	423	402	416	*	*	*	*		
	Pt3	104	119	172	189	250	311	404	463	513	593	824	869	818	857	*	*	*	*		
	Pt4	129	147	214	232	306	372	491	560	610	704	978	1028	954	995	*	*	*	*		
35.5	Pt1	46.6	53.6	71.1	81.4	95.5	101	133	156	174	198	226	242	231	244	285	296	317	298		
	Pt2	73.6	84.0	115	131	156	163	224	262	286	326	401	428	399	425	*	*	*	*		
	Pt3	100	112	166	187	239	303	384	436	491	561	770	838	764	828	*	*	*	*		
	Pt4	123	140	206	232	295	363	469	531	588	671	923	1004	902	973	*	*	*	*		
40.0	Pt1	44.2	52.1	67.8	78.4	90.7	98.1	129	153	170	196	223	236	227	240	285	299	328	316		
	Pt2	69.5	81.6	109	125	148	159	216	256	277	319	391	414	391	412	*	*	*	*		
	Pt3	93.1	108	154	176	223	290	362	415	464	538	728	780	726	771	*	*	*	*		
	Pt4	114	134	193	219	275	349	443	507	558	646	879	939	860	913	*	*	*	*		
45.0	Pt1	42.3	50.4	65.5	76.2	87.6	95.8	129	148	164	190	224	231	228	234	287	293	327	319		
	Pt2	66.5	78.8	105	122	142	155	216	247	266	309	392	401	390	400	*	*	*	*		
	Pt3	88.0	103	147	169	211	277	354	395	438	512	715	738	712	729	*	*	*	*		
	Pt4	108	128	184	210	261	336	436	483	526	615	864	888	845	865	*	*	*	*		
50.0	Pt1	41.2	47.9	62.4	73.3	86.9	92.1	130	147	167	191	237	244	241	250	306	315	372	363		
	Pt2	64.5	74.7	100	116	140	148	214	243	267	307	403	418	402	418	*	*	*	*		
	Pt3	85.2	96.5	139	159	207	259	349	375	429	487	715	731	705	721	*	*	*	*		
	Pt4	105	119	172	197	255	313	429	461	520	592	869	889	849	870	*	*	*	*		
56.0	Pt1	39.3	46.2	59.9	71.1	83.4	89.5	121	149	164	187	233	250	239	255	306	325	381	394		
	Pt2	61.3	71.8	95.6	112	134	143	201	245	262	298	392	422	395	422	*	*	*	*		
	Pt3	80.1	91.5	131	151	194	246	317	368	408	460	671	727	665	714	*	*	*	*		
	Pt4	98.8	113	163	189	241	298	391	455	496	561	821	886	805	863	*	*	*	*		
63.0	Pt1	37.1	44.8	56.2	67.7	79.6	88.2	117	148	159	186	226	247	234	254	299	326	390	406		
	Pt2	57.7	69.3	89.4	107	126	140	192	241	252	295	378	413	383	414	*	*	*	*		
	Pt3	74.3	88.3	120	142	180	240	295	363	381	450	623	680	619	672	*	*	*	*		
	Pt4	92.0	109	149	177	224	292	364	448	465	551	768	840	756	820	*	*	*	*		
71.0	Pt1	36.8	42.4	54.6	64.5	77.9	84.0	114	138	155	181	221	235	226	241	296	307	372	393		
	Pt2	57.1	65.6	86.5	102	124	134	186	223	244	285	368	390	368	393	*	*	*	*		
	Pt3	73.4	82.8	115	133	176	224	285	327	364	427	601	632	593	623	*	*	*	*		
	Pt4	91.0	102	144	166	218	272	352	406	445	522	740	779	726	761	*	*	*	*		
80.0	Pt1	35.0	40.0	53.3	60.3	73.8	79.6	108	131	151	170	214	228	218	233	283	305	359	375		
	Pt2	54.1	61.5	84.5	94.8	116	125	175	211	238	269	355	378	355	378	*	*	*	*		
	Pt3	68.2	77.0	111	122	163	208	262	304	351	397	567	608	561	598	*	*	*	*		
	Pt4	84.7	95.5	139	153	204	253	325	377	428	488	702	750	686	730	*	*	*	*		
90.0	Pt1	34.6	39.7	50.5	58.3	70.2	77.7	105	128	141	166	203	221	207	224	269	290	352	362		
	Pt2	53.4	61.0	79.9	91.5	111	121	169	205	222	261	335	365	336	364	*	*	*	*		
	Pt3	66.4	76.3	102	117	152	204	252	294	322	379	525	574	519	566	*	*	*	*		
	Pt4	82.6	94.6	129	148	190	247	313	365	396	464	650	711	638	694	*	*	*	*		
100	Pt1	-	37.7	-	57.4	-	74.2	-	121	-	163	-	211	-	216	-	282	-	365		
	Pt2	-	57.9	-	89.9	-	116	-	195	-	256	-	347	-	347	-	*	-	*		
	Pt3	-	70.9	-	114	-	190	-	272	-	366	-	533	-	525	-	*	-	*		
	Pt4	-	88.2	-	143	-	231	-	339	-	450	-	661	-	647	-	*	-	*		
112	Pt1	-	37.3	-	54.4	-	70.6	-	118	-	153	-	-	-	-	-	-	-	-		
	Pt2	-	57.3	-	85.1	-	110	-	189	-	240	-	-	-	-	-	-	-	-		
	Pt3	-	69.2	-	105	-	175	-	262	-	337	-	-	-	-	-	-	-	-		
	Pt4	-	86.0	-	133	-	215	-	326	-	415	-	-	-	-	-	-	-	-		

* Talep edildiğinde

- A) Değerler aşağıda belirtilen şartlar için geçerlidir:
Saatlik çalışma döngüsü: %100
Büyük bir alanda kurulum rakım 1000 m'ye kadar
- B) Değerler aşağıda belirtilen şartlar için geçerlidir:
Soğutma suyu, çıkış su sıcaklığı ne olursa olsun, soğuk su giriş sıcaklığı 20°C olmalıdır.
Soğutma suyu çıkış sıcaklığının sınırlanmasına ilişkin hesaplama, ancak talep edildiğinde sağlanır.

* On request

- A) Values refer to:
Operating cycle: 100%
Installation in a large hall Altitude up to 1000 m
- B) Values refer to:
A cooling water inlet temperature of 20°C with unlimited cooling water outlet temperature.
A recalculation with a limited cooling water outlet temperature is possible on request.

* Auf Anfrage

- A) Werte gelten für:
Einschaltdauer: 100%
Aufstellung in großer Halle Höhenlage bis 1000 m
- B) Werte gelten für:
Eine Kühlwassereintrittstemperatur von 20°C ohne Begrenzung der Kühlwasseraustrittstemperatur.
Die Nachrechnung mit Begrenzung der Kühlwasser austrittstemperatur ist auf Anfrage möglich.

Pt1 Redüktörler, ilave soğutucusu yok. **A**
Pt2 Redüktörler, fan soğutucusu. **A**
Pt3 Redüktörler, monte edilmiş serpantinli soğutucu. **A,B**
Pt4 Redüktörler, fanlı ve monte edilmiş serpantinli soğutucusu. **A,B**

Pt1 Gear units without auxiliary cooling **A**
Pt2 Gear units with fan **A**
Pt3 Gear units with built-in cooling coil **A,B**
Pt4 Gear units with fan and built-in cooling coil **A,B**

Pt1 Getriebe ohne Zusatzkühlung **A**
Pt2 Getriebe mit Lüfterkühlung **A**
Pt3 Getriebe mit eingebauter Kühlschlange **A,B**
Pt4 Getriebe mit Lüfter und eingebauter Kühlschlange **A,B**

TR TERMAL KAPASİTELER Pt (kW)

EN THERMAL CAPACITIES Pt (kW)

DE WÄRMEGRENZLEISTUNGEN Pt (kW)

İN	Pt (kW)	Redüktör Gövdeleri / Gear unit sizes / Getriebegrößen																n ₁ =1500 min ⁻¹			
		53	63	73	83	93	103	113	123	133	143	153	163	173	183	193	203	213	223		
22.4	Pt1	-	-	-	-	-	-	-	-	172	-	197	-	184	-	*	-	*	-		
	Pt2	-	-	-	-	-	-	-	-	353	-	472	-	459	-	*	-	*	-		
	Pt3	-	-	-	-	-	-	-	-	681	-	1071	-	1056	-	*	-	*	-		
	Pt4	-	-	-	-	-	-	-	-	827	-	1292	-	1253	-	*	-	*	-		
25.0	Pt1	53.6	-	77.6	-	102	-	141	-	170	-	196	197	184	*	*	*	*	*		
	Pt2	94.2	-	141	-	191	-	281	-	345	-	462	479	451	464	*	*	*	*		
	Pt3	133	-	212	-	308	-	517	-	649	-	1012	1080	999	1056	*	*	*	*		
	Pt4	166	-	266	-	386	-	639	-	786	-	1225	1303	1187	1252	*	*	*	*		
28.0	Pt1	51.9	-	79.1	-	103	-	140	-	172	195	210	211	202	200	226	*	*	*		
	Pt2	91.2	-	143	-	190	-	273	-	341	388	472	485	464	473	*	*	*	*		
	Pt3	125	-	211	-	300	-	487	-	612	715	985	1028	972	1008	*	*	*	*		
	Pt4	158	-	266	-	375	-	605	-	749	871	1203	1248	1168	1206	*	*	*	*		
31.5	Pt1	50.9	58.5	76.8	84.5	102	104	140	162	176	200	221	226	216	220	251	254	*	*		
	Pt2	88.6	102	138	151	187	192	268	314	339	385	477	497	472	490	*	*	*	*		
	Pt3	120	138	199	218	289	359	466	533	592	683	949	1001	942	986	*	*	*	*		
	Pt4	152	173	253	273	362	441	581	663	724	835	1166	1226	1138	1188	*	*	*	*		
35.5	Pt1	49.6	56.8	75.4	86.1	101	106	138	161	179	202	226	240	225	237	273	282	278	*		
	Pt2	86.0	98.1	135	153	182	190	262	306	335	381	470	503	268	499	*	*	*	*		
	Pt3	115	130	192	215	276	350	443	502	566	647	887	967	880	954	*	*	*	*		
	Pt4	146	164	244	273	349	429	555	629	697	797	1097	1194	1073	1160	*	*	*	*		
40.0	Pt1	47.0	55.4	72.0	83.0	95.8	103	135	159	175	201	225	237	225	236	277	289	299	274		
	Pt2	81.1	95.3	128	147	173	186	253	299	324	373	458	486	468	483	*	*	*	*		
	Pt3	107	124	179	204	257	334	418	479	536	620	839	900	836	888	*	*	*	*		
	Pt4	136	157	227	259	325	412	524	601	662	765	1044	1116	1023	1087	*	*	*	*		
45.0	Pt1	45.1	53.6	69.6	80.8	92.6	101	135	154	169	196	227	232	228	232	282	286	303	284		
	Pt2	77.6	92.0	122	143	165	181	252	289	312	362	459	469	457	469	*	*	*	*		
	Pt3	102	119	170	196	244	320	409	456	505	591	825	852	820	839	*	*	*	*		
	Pt4	129	151	216	248	309	396	515	572	623	728	1026	1055	1005	1029	*	*	*	*		
50.0	Pt1	44.1	51.1	66.5	78.1	92.4	97.8	137	154	174	199	245	251	247	255	310	319	367	351		
	Pt2	75.3	87.2	116	136	163	172	251	284	312	359	471	489	471	490	*	*	*	*		
	Pt3	98.3	111	160	185	240	299	403	434	495	562	825	844	813	831	*	*	*	*		
	Pt4	124	141	204	233	301	369	507	545	615	700	1029	1054	1007	1032	*	*	*	*		
56.0	Pt1	42.0	49.5	64.0	75.9	89.0	95.3	130	157	173	196	244	261	248	265	316	336	387	395		
	Pt2	71.5	83.8	111	132	156	167	235	286	306	348	458	494	462	495	*	*	*	*		
	Pt3	92.4	105	151	175	223	284	366	425	470	531	774	838	767	824	*	*	*	*		
	Pt4	116	134	192	222	284	351	461	538	585	663	971	1049	953	1021	*	*	*	*		
63.0	Pt1	39.9	47.9	60.2	72.4	85.2	94.4	124	157	169	198	240	260	246	267	313	343	405	419		
	Pt2	67.4	80.8	104	124	148	163	223	282	294	345	443	482	448	483	*	*	*	*		
	Pt3	85.8	102	139	164	208	277	366	425	470	531	774	838	767	824	*	*	*	*		
	Pt4	108	129	175	209	264	345	429	528	549	650	907	992	894	969	*	*	*	*		
71.0	Pt1	39.5	45.5	58.4	69.1	83.4	90.0	122	147	165	192	235	248	239	254	312	322	389	408		
	Pt2	66.6	76.5	101	118	145	156	217	261	285	332	430	456	430	459	*	*	*	*		
	Pt3	84.8	95.7	133	154	204	260	328	378	420	494	694	729	684	720	*	*	*	*		
	Pt4	107	120	169	196	257	321	415	478	525	617	874	920	858	899	*	*	*	*		
80.0	Pt1	37.5	42.9	57.1	64.6	79.2	85.2	115	139	161	182	227	242	232	246	298	321	376	392		
	Pt2	63.1	71.7	98.5	110	137	146	205	246	277	314	414	443	414	442	*	*	*	*		
	Pt3	78.8	88.9	128	142	189	241	303	352	406	458	655	702	648	690	*	*	*	*		
	Pt4	99.9	112	163	181	241	299	385	446	506	575	828	885	811	863	*	*	*	*		
90.0	Pt1	37.0	42.6	54.2	62.6	75.3	83.2	112	137	151	176	215	236	219	238	286	306	370	379		
	Pt2	62.3	71.2	93.1	106	130	143	198	240	260	304	391	426	392	425	*	*	*	*		
	Pt3	76.6	88.1	118	136	175	236	291	340	372	439	607	664	600	653	*	*	*	*		
	Pt4	97.4	111	151	174	223	292	369	430	467	548	767	839	753	819	*	*	*	*		
100	Pt1	-	40.5	-	61.6	-	79.6	-	131	-	174	-	225	-	231	-	*	-	387		
	Pt2	-	67.5	-	104	-	136	-	227	-	299	-	405	-	405	-	*	-	*		
	Pt3	-	81.9	-	132	-	219	-	314	-	423	-	616	-	607	-	*	-	*		
	Pt4	-	103	-	168	-	271	-	400	-	530	-	779	-	763	-	*	-	*		
112	Pt1	-	40.1	-	58.3	-	75.8	-	126	-	164	-	-	-	-	-	-	-	-		
	Pt2	-	66.9	-	99.2	-	130	-	220	-	279	-	-	-	-	-	-	-	-		
	Pt3	-	79.9	-	121	-	203	-	302	-	390	-	-	-	-	-	-	-	-		
	Pt4	-	101	-	156	-	253	-	385	-	489	-	-	-	-	-	-	-	-		

***** Talep edildiğinde

- A) Değerler aşağıda belirtilen şartlar için geçerlidir:
 Saatlik çalışma döngüsü: %100
 Büyük bir alanda kurulum rakım 1000 m'ye kadar
- B) Değerler aşağıda belirtilen şartlar için geçerlidir:
 Soğutma suyu, çıkış su sıcaklığı ne olursa olsun, soğuk su giriş sıcaklığı 20°C olmalıdır.
 Soğutma suyu çıkış sıcaklığının sınırlanmasına ilişkin hesaplama, ancak talep edildiğinde sağlanır.

***** On request

- A) Values refer to:
 Operating cycle: 100%
 Installation in a large hall Altitude up to 1000 m
- B) Values refer to:
 A cooling water inlet temperature of 20°C with unlimited cooling water outlet temperature.
 A recalculation with a limited cooling water outlet temperature is possible on request.

***** Auf Anfrage

- A) Werte gelten für:
 Einschaltdauer: 100%
 Aufstellung in großer Halle Höhenlage bis 1000 m
- B) Werte gelten für:
 Eine Kühlwassereintrittstemperatur von 20°C ohne Begrenzung der Kühlwasseraustrittstemperatur.
 Die Nachrechnung mit Begrenzung der Kühlwasser austrittstemperatur ist auf Anfrage möglich.

Pt1 Redüktörler, ilave soğutucusu yok. **A**
Pt2 Redüktörler, fan soğutucusu. **A**
Pt3 Redüktörler, monte edilmiş serpantinli soğutucu. **A,B**
Pt4 Redüktörler, fanlı ve monte edilmiş serpantinli soğutucu. **A,B**
Pt1 Gear units without auxiliary cooling **A**
Pt2 Gear units with fan **A**
Pt3 Gear units with built-in cooling coil **A,B**
Pt4 Gear units with fan and built-in cooling coil **A,B**
Pt1 Getriebe ohne Zusatzkühlung **A**
Pt2 Getriebe mit Lüfterkühlung **A**
Pt3 Getriebe mit eingebauter Kühlschlange **A,B**
Pt4 Getriebe mit Lüfter und eingebauter Kühlschlange **A,B**

TR TERMAL KAPASİTELER Pt (kW)

EN THERMAL CAPACITIES Pt (kW)

DE WÄRMEGRENZLEISTUNGEN Pt (kW)

İN	Pt (kW)	Redüktör Gövdeleri / Gear unit sizes / Getriebegrößen																	n ₁ =1800 min ⁻¹			
		53	63	73	83	93	103	113	123	133	143	153	163	173	183	193	203	213	223			
22.4	Pt1	-	-	-	-	-	-	-	-	144	-	*	-	*	-	*	-	*	-			
	Pt2	-	-	-	-	-	-	-	-	359	-	455	-	424	-	*	-	*	-			
	Pt3	-	-	-	-	-	-	-	-	727	-	1125	-	1098	-	*	-	*	-			
	Pt4	-	-	-	-	-	-	-	-	899	-	1377	-	1316	-	*	-	*	-			
25.0	Pt1	54.0	-	77.1	-	99.7	-	129	-	143	-	*	*	*	*	*	*	*	*			
	Pt2	103	-	153	-	205	-	295	-	352	-	448	457	419	422	*	*	*	*			
	Pt3	146	-	232	-	336	-	558	-	693	-	1064	1132	1040	1093	*	*	*	*			
	Pt4	187	-	298	-	429	-	703	-	856	-	1308	1383	1251	1311	*	*	*	*			
28.0	Pt1	52.6	-	79.2	-	102	-	132	-	151	168	*	*	*	*	*	*	*	*			
	Pt2	99.9	-	156	-	206	-	291	-	353	400	469	475	448	448	*	*	*	*			
	Pt3	138	-	231	-	327	-	526	-	657	766	1043	1085	1021	1054	*	*	*	*			
	Pt4	177	-	298	-	419	-	668	-	819	951	1294	1338	1243	1277	*	*	*	*			
31.5	Pt1	51.9	59.5	77.5	84.6	102	103	134	152	160	180	183	182	*	*	*	*	*	*			
	Pt2	97.4	111	150	165	203	208	287	334	355	402	485	500	468	479	*	*	*	*			
	Pt3	133	151	218	239	315	392	506	577	638	735	1012	1064	998	1040	*	*	*	*			
	Pt4	171	195	285	307	405	492	645	733	797	918	1265	1326	1224	1273	*	*	*	*			
35.5	Pt1	50.8	58.0	76.6	87.0	101	106	135	155	167	188	198	205	188	191	212	*	*	*	*		
	Pt2	94.8	107	148	167	199	207	283	328	355	404	487	517	476	503	*	*	*	*			
	Pt3	126	143	210	237	302	383	481	546	613	700	952	1035	938	1015	*	*	*	*			
	Pt4	164	186	273	307	391	480	618	699	770	879	1200	1304	1167	1256	*	*	*	*			
40.0	Pt1	48.2	56.8	73.4	84.4	96.8	103	133	154	167	190	203	209	194	198	227	232	*	*	*	*	
	Pt2	89.5	104	141	161	190	203	273	321	346	398	478	505	471	494	*	*	*	*	*	*	
	Pt3	118	138	196	223	283	366	456	521	581	672	905	966	896	949	*	*	*	*	*	*	
	Pt4	152	176	255	291	364	462	584	668	733	848	1146	1223	1117	1183	*	*	*	*	*	*	
45.0	Pt1	46.4	55.0	71.1	82.2	93.8	102	134	150	162	187	207	208	200	198	236	235	*	*	*	*	
	Pt2	85.7	101	135	157	182	198	273	311	334	387	481	491	473	482	*	*	*	*	*	*	
	Pt3	111	132	187	215	267	352	447	497	548	641	889	916	880	900	*	*	*	*	*	*	
	Pt4	144	169	244	278	347	444	574	636	692	808	1129	1158	1099	1123	*	*	*	*	*	*	
50.0	Pt1	45.6	52.9	68.6	80.3	94.8	100	138	155	173	197	236	239	233	238	286	291	309	279	*	*	
	Pt2	83.3	96.5	129	150	181	190	274	309	339	389	505	522	501	518	*	*	*	*	*	*	
	Pt3	108	122	175	203	263	328	442	474	541	613	897	915	881	899	*	*	*	*	*	*	
	Pt4	140	158	230	262	339	415	569	610	686	781	1142	1169	1114	1139	*	*	*	*	*	*	
56.0	Pt1	43.8	51.4	66.3	78.5	91.9	98.1	132	160	174	198	241	257	242	257	304	321	354	350	*	*	
	Pt2	79.3	92.9	123	146	172	185	258	313	336	380	497	533	498	531	*	*	*	*	*	*	
	Pt3	102	116	166	193	246	312	403	467	515	581	846	915	836	897	*	*	*	*	*	*	
	Pt4	132	151	216	251	320	396	518	604	657	743	1084	1170	1061	1136	*	*	*	*	*	*	
63.0	Pt1	41.6	50.0	62.7	75.4	88.5	97.9	129	162	173	202	243	263	248	267	313	341	394	402	*	*	
	Pt2	74.9	89.8	115	138	163	181	247	310	323	379	485	527	489	527	*	*	*	*	*	*	
	Pt3	94.6	112	153	182	230	305	375	461	483	571	789	861	782	849	*	*	*	*	*	*	
	Pt4	122	146	198	237	299	389	485	596	618	730	1018	1113	1001	1085	*	*	*	*	*	*	
71.0	Pt1	41.2	47.5	61.0	71.9	86.8	93.4	126	152	169	197	239	252	242	256	313	323	381	395	*	*	
	Pt2	74.1	85.0	111	132	161	173	240	289	314	366	472	500	471	502	*	*	*	*	*	*	
	Pt3	93.5	105	147	169	224	287	362	416	462	543	761	801	750	788	*	*	*	*	*	*	
	Pt4	120	137	192	221	291	363	467	540	592	695	981	1032	962	1007	*	*	*	*	*	*	
80.0	Pt1	39.2	44.9	59.7	67.3	82.4	88.5	120	144	165	187	233	247	235	249	301	323	372	384	*	*	
	Pt2	70.2	79.8	109	122	151	162	226	272	306	347	456	486	455	485	*	*	*	*	*	*	
	Pt3	87.0	98.1	141	156	208	265	334	388	446	504	719	771	710	757	*	*	*	*	*	*	
	Pt4	112	126	185	204	271	338	434	502	570	648	930	995	910	968	*	*	*	*	*	*	
90.0	Pt1	38.8	44.5	56.5	65.3	78.4	86.7	116	142	155	183	221	241	223	242	290	310	369	375	*	*	
	Pt2	69.3	79.2	103	118	144	158	219	265	288	337	430	469	430	467	*	*	*	*	*	*	
	Pt3	84.6	97.2	131	150	194	259	320	374	409	482	667	729	658	717	*	*	*	*	*	*	
	Pt4	109	125	171	197	252	329	417	486	526	617	863	944	846	920	*	*	*	*	*	*	
100	Pt1	-	42.4	-	64.5	-	83.2	-	136	-	182	-	234	-	238	-	309	-	393	*	*	
	Pt2	-	75.2	-	116	-	151	-	252	-	332	-	449	-	448	-	*	-	*	*	*	
	Pt3	-	90.4	-	145	-	242	-	347	-	466	-	678	-	668	-	*	-	*	*	*	
	Pt4	-	117	-	190	-	307	-	451	-	599	-	879	-	860	-	*	-	*	*	*	
112	Pt1	-	42.0	-	61.1	-	79.4	-	133	-	171	-	-	-	-	-	-	-	-	-	-	
	Pt2	-	74.5	-	110	-	144	-	245	-	311	-	-	-	-	-	-	-	-	-	-	
	Pt3	-	88.1	-	135	-	224	-	334	-	429	-	-	-	-	-	-	-	-	-	-	
	Pt4	-	114	-	176	-	287	-	435	-	553	-	-	-	-	-	-	-	-	-	-	

* Talep edildiğinde

- A) Değerler aşağıda belirtilen şartlar için geçerlidir:
Saatlik çalışma döngüsü: %100
Büyük bir alanda kurulum rakım 1000 m'ye kadar
- B) Değerler aşağıda belirtilen şartlar için geçerlidir:
Soğutma suyu, çıkış su sıcaklığı ne olursa olsun, soğuk su giriş sıcaklığı 20°C olmalıdır.
Soğutma suyu çıkış sıcaklığının sınırlanmasına ilişkin hesaplama, ancak talep edildiğinde sağlanır.

* On request

- A) Values refer to:
Operating cycle: 100%
Installation in a large hall Altitude up to 1000 m
- B) Values refer to:
A cooling water inlet temperature of 20°C with unlimited cooling water outlet temperature.
A recalculation with a limited cooling water outlet temperature is possible on request.

* Auf Anfrage

- A) Werte gelten für:
Einschaltdauer: 100%
Aufstellung in großer Halle Höhenlage bis 1000 m
- B) Werte gelten für:
Eine Kühlwassereintrittstemperatur von 20°C ohne Begrenzung der Kühlwasseraustrittstemperatur.
Die Nachrechnung mit Begrenzung der Kühlwasser austrittstemperatur ist auf Anfrage möglich.

Pt1 Redüktörler, ilave soğutucusu yok. A

Pt2 Redüktörler, fan soğutucusu. A

Pt3 Redüktörler, monte edilmiş serpantinli soğutucu. A,B

Pt4 Redüktörler, fanlı ve monte edilmiş serpantinli soğutucu. A,B

Pt1 Gear units without auxiliary cooling A

Pt2 Gear units with fan A

Pt3 Gear units with built-in cooling coil A,B

Pt4 Gear units with fan and built-in cooling coil A,B

Pt1 Getriebe ohne Zusatzkühlung A

Pt2 Getriebe mit Lüfterkühlung A

Pt3 Getriebe mit eingebauter Kühlschlange A,B

Pt4 Getriebe mit Lüfter und eingebauter Kühlschlange A,B

TR NOMİNAL GÜÇ DEĞERLERİ P_{2N} (kW)EN NOMINAL POWER RATINGS P_{2N} (kW)DE NENNLEISTUNGEN P_{2N} (kW)

iN	n1 min-1	n2 min-1	Redüktör Gövdeleri / Gear unit sizes / Getriebegrößen															
			74	84	94	104	114	124	134	144	154	164	174	184	194	204	214	224
100	1800	18.0	41.0	-	68.0	-	118	-	173	-	294	-	384	-	576	-	807	-
	1500	15.0	35.0	-	57.0	-	98.0	-	145	-	245	-	320	-	480	-	672	-
	1200	12.0	28.0	-	45.0	-	79.0	-	115	-	196	-	256	-	384	-	538	-
	1000	10.0	22.0	-	38.0	-	65.0	-	96.0	-	163	-	213	-	320	-	448	-
112	1800	16.1	37.0	-	61.0	-	105	-	155	-	262	297	344	412	515	593	722	808
	1500	13.4	31.0	-	51.0	-	88.0	-	130	-	218	247	286	343	428	494	601	672
	1200	10.7	24.0	-	40.0	-	70.0	-	103	-	174	197	228	273	343	394	479	537
	1000	8.9	20.0	-	34.0	-	58.0	-	86.0	-	145	164	190	227	285	327	399	447
125	1800	14.4	33.0	42.0	54.0	67.0	94.0	119	139	173	235	265	307	368	461	530	646	722
	1500	12.0	28.0	35.0	45.0	56.0	79.0	100	115	144	196	221	256	307	384	442	538	602
	1200	9.6	21.0	28.0	36.0	45.0	62.0	80.0	93.0	115	156	176	205	246	307	353	430	481
	1000	8.0	18.0	22.0	30.0	38.0	52.0	66.0	77.0	96.0	131	147	170	205	256	295	358	401
140	1800	12.9	30.0	37.0	49.0	60.0	85.0	107	124	155	210	238	275	330	413	475	578	647
	1500	10.7	25.0	31.0	40.0	50.0	70.0	89.0	103	129	174	197	228	273	343	394	479	537
	1200	8.6	19.0	25.0	33.0	40.0	56.0	71.0	83.0	103	140	158	184	220	275	316	386	431
	1000	7.1	16.0	20.0	27.0	33.0	46.0	58.0	68.0	86.0	115	131	151	182	227	261	318	356
160	1800	11.3	26.0	33.0	43.0	53.0	73.0	94.0	109	136	185	208	241	289	361	416	506	567
	1500	9.4	21.0	27.0	36.0	44.0	61.0	78.0	91.0	113	153	173	200	241	301	346	421	471
	1200	7.5	17.0	21.0	29.0	35.0	49.0	62.0	72.0	90.0	122	138	160	192	240	275	336	376
	1000	6.3	14.0	17.0	24.0	30.0	41.0	52.0	60.0	76.0	102	116	134	161	201	232	283	316
180	1800	10.0	22.0	29.0	38.0	47.0	65.0	83.0	96.0	120	163	185	213	256	320	368	448	502
	1500	8.3	18.0	24.0	32.0	39.0	54.0	68.0	80.0	100	135	153	176	212	265	305	372	416
	1200	6.7	15.0	19.0	26.0	32.0	44.0	55.0	64.0	81.0	109	123	143	171	214	247	300	336
	1000	5.6	12.0	15.0	20.0	26.0	37.0	46.0	54.0	67.0	91.0	103	119	143	179	206	251	281
200	1800	9.0	20.0	26.0	34.0	42.0	59.0	75.0	87.0	108	147	166	192	231	288	332	403	451
	1500	7.5	17.0	21.0	29.0	35.0	49.0	62.0	72.0	90.0	122	138	160	192	240	275	336	376
	1200	6.0	13.0	17.0	22.0	28.0	39.0	50.0	57.0	71.0	98.0	110	128	153	192	220	268	301
	1000	5.0	11.0	14.0	18.0	24.0	33.0	41.0	48.0	60.0	82.0	92.0	106	128	160	184	223	251
224	1800	8.0	18.0	22.0	30.0	38.0	52.0	66.0	77.0	96.0	131	147	170	205	256	295	358	401
	1500	6.7	15.0	19.0	26.0	32.0	44.0	55.0	64.0	81.0	109	123	143	171	214	247	300	336
	1200	5.4	12.0	15.0	20.0	25.0	35.0	45.0	52.0	64.0	88.0	99.0	115	138	172	199	242	270
	1000	4.5	10.0	12.0	16.0	20.0	30.0	37.0	43.0	54.0	73.0	83.0	96.0	115	144	165	201	225
250	1800	7.2	16.0	20.0	27.0	34.0	47.0	59.0	69.0	87.0	117	133	153	184	231	265	322	361
	1500	6.0	13.0	17.0	22.0	28.0	39.0	50.0	57.0	71.0	98.0	110	128	153	192	220	268	301
	1200	4.8	10.0	13.0	17.0	22.0	31.0	40.0	46.0	57.0	76.0	88.0	102	122	153	176	215	241
	1000	4.0	9.0	11.0	14.0	18.0	26.0	33.0	38.0	48.0	65.0	73.0	85.0	102	128	147	179	200
280	1800	6.4	14.0	18.0	24.0	30.0	42.0	53.0	61.0	77.0	104	117	137	163	205	236	287	320
	1500	5.4	12.0	15.0	20.0	25.0	35.0	45.0	52.0	64.0	88.0	99.0	115	138	172	199	242	270
	1200	4.3	10.0	12.0	16.0	19.0	28.0	36.0	41.0	51.0	69.0	79.0	92.0	110	138	158	193	215
	1000	3.6	8.0	10.0	13.0	16.0	24.0	30.0	35.0	43.0	58.0	66.0	77.0	92.0	115	133	161	181
315	1800	5.7	12.0	16.0	21.0	27.0	37.0	47.0	55.0	68.0	93.0	105	121	146	183	209	255	286
	1500	4.8	10.0	13.0	17.0	22.0	31.0	40.0	46.0	57.0	78.0	88.0	102	122	153	176	215	241
	1200	3.8	9.0	10.0	14.0	17.0	25.0	32.0	37.0	45.0	61.0	69.0	81.0	97.0	121	140	170	191
	1000	3.2	7.0	9.0	11.0	14.0	20.0	27.0	31.0	38.0	52.0	58.0	68.0	82.0	102	117	143	160
355	1800	5.1	10.0	14.0	19.0	24.0	33.0	42.0	49.0	61.0	76.0	94.0	104	131	157	188	222	255
	1500	4.2	9.0	11.0	15.0	19.0	28.0	35.0	40.0	50.0	62.0	78.0	86.0	107	130	154	184	210
	1200	3.4	7.0	10.0	12.0	15.0	21.0	28.0	33.0	41.0	50.0	62.0	69.0	87.0	105	124	148	170
	1000	2.8	6.0	8.0	10.0	12.0	18.0	22.0	27.0	34.0	42.0	51.0	57.0	71.0	87.0	103	122	140
400	1800	4.5	-	12.0	-	20.0	-	37.0	-	54.0	-	76.0	-	107	-	160	-	223
	1500	3.8	-	10.0	-	17.0	-	32.0	-	45.0	-	63.0	-	90.0	-	136	-	189
	1200	3.0	-	9.0	-	13.0	-	25.0	-	36.0	-	50.0	-	71.0	-	107	-	149
	1000	2.5	-	7.0	-	11.0	-	20.0	-	30.0	-	42.0	-	59.0	-	89.0	-	123
450	1800	4.0	-	10.0	-	17.0	-	33.0	-	48.0	-	-	-	-	-	-	-	-
	1500	3.3	-	9.0	-	14.0	-	27.0	-	40.0	-	-	-	-	-	-	-	-
	1200	2.7	-	7.0	-	12.0	-	22.0	-	32.0	-	-	-	-	-	-	-	-
	1000	2.2	-	6.0	-	10.0	-	17.0	-	27.0	-	-	-	-	-	-	-	-

TR NÖMİNAL ÇIKIŞ MOMENTLERİ T_{2N} (kNm)

EN NOMINAL OUTPUT TORQUES T_{2N} (kNm)

DE NENN-ABTRIEBSDREHMOMENTE T_{2N} (kNm)

İN	Redüktör Gövdeleri / Gear unit sizes / Getriebegrößen															
	74	84	94	104	114	124	134	144	154	164	174	184	194	204	214	224
100	22.1	-	36.4	-	62.8	-	92.5	-	156.1	-	204.0	-	306.0	-	428.4	-
112	22.1	-	36.4	-	62.8	-	92.5	-	156.1	176.5	204.0	244.8	306.0	351.9	428.4	479.4
125	22.1	27.7	36.4	45.1	62.8	79.6	92.5	115.3	156.1	176.5	204.0	244.8	306.0	351.9	428.4	479.4
140	22.1	27.7	36.4	45.1	62.8	79.6	92.5	115.3	156.1	176.5	204.0	244.8	306.0	351.9	428.4	479.4
160	22.1	27.7	36.4	45.1	62.8	79.6	92.5	115.3	156.1	176.5	204.0	244.8	306.0	351.9	428.4	479.4
180	22.1	27.7	36.4	45.1	62.8	79.6	92.5	115.3	156.1	176.5	204.0	244.8	306.0	351.9	428.4	479.4
200	22.1	27.7	36.4	45.1	62.8	79.6	92.5	115.3	156.1	176.5	204.0	244.8	306.0	351.9	428.4	479.4
224	22.1	27.7	36.4	45.1	62.8	79.6	92.5	115.3	156.1	176.5	204.0	244.8	306.0	351.9	428.4	479.4
250	22.1	27.7	36.4	45.1	62.8	79.6	92.5	115.3	156.1	176.5	204.0	244.8	306.0	351.9	428.4	479.4
280	22.1	27.7	36.4	45.1	62.8	79.6	92.5	115.3	156.1	176.5	204.0	244.8	306.0	351.9	428.4	479.4
315	22.1	27.7	36.4	45.1	62.8	79.6	92.5	115.3	156.1	176.5	204.0	244.8	306.0	351.9	428.4	479.4
355	20.0	27.7	36.4	45.1	62.8	79.6	92.5	115.3	142.8	176.5	195.8	244.8	295.8	351.9	418.2	479.4
400	-	27.7	-	45.1	-	79.6	-	115.3	-	161.2	-	227.5	-	341.7	-	474.3
450	-	25.8	-	43.7	-	79.6	-	115.3	-	-	-	-	-	-	-	-

TR TERMAL KAPASİTELER Pt (kW)

EN THERMAL CAPACITIES Pt (kW)

DE WÄRMEGRENZLEISTUNGEN Pt (kW)

İN	Pt (kW)	Redüktör Gövdeleri / Gear unit sizes / Getriebegrößen															
		74	84	94	104	114	124	134	144	154	164	174	184	194	204	214	224
100	Pt1	44.5	-	62.0	-	91.9	-	122	-	164	-	184	-	258	-	353	-
112	Pt1	42.8	-	59.4	-	91.2	-	119	-	157	169	176	189	248	265	347	357
125	Pt1	41.6	47.7	57.5	62.3	87.5	102	116	131	152	163	170	181	240	254	337	351
140	Pt1	39.5	45.8	55.7	59.7	84.7	101	112	128	147	156	164	174	232	246	319	341
160	Pt1	37.9	44.5	52.6	57.8	80.6	97.2	106	123	141	151	157	168	222	237	307	323
180	Pt1	36.5	42.2	50.4	56.0	77.7	93.6	102	120	139	145	154	161	212	228	303	310
200	Pt1	35.1	40.7	48.8	52.8	73.4	89.4	100	113	135	142	149	159	205	218	286	306
224	Pt1	33.0	39.0	46.8	50.6	70.4	86.1	95.6	109	125	139	139	154	197	210	273	289
250	Pt1	31.6	37.7	44.7	49.2	66.9	81.3	90.9	106	119	129	133	144	187	202	258	275
280	Pt1	30.7	35.4	43.4	47.1	64.4	78.2	88.0	101	115	122	129	136	180	192	248	260
315	Pt1	30.0	34.0	41.3	45.0	62.8	74.2	84.5	97.4	110	118	123	133	175	185	238	250
355	Pt1	28.7	32.9	40.6	43.7	59.8	71.3	80.5	93.7	108	113	120	126	167	181	226	241
400	Pt1	-	32.2	-	41.6	-	69.7	-	90.1	-	111	-	123	-	171	-	230
450	Pt1	-	30.7	-	40.9	-	66.2	-	85.9	-	-	-	-	-	-	-	-

İN	Pt (kW)	Redüktör Gövdeleri / Gear unit sizes / Getriebegrößen															
		74	84	94	104	114	124	134	144	154	164	174	184	194	204	214	224
100	Pt1	46.3	-	64.4	-	94.2	-	123	-	163	-	182	-	251	-	332	-
112	Pt1	44.8	-	61.8	-	94.2	-	122	-	159	170	176	189	246	262	336	342
125	Pt1	43.6	50.0	60.0	65.0	90.8	105	119	135	155	165	172	183	242	255	332	342
140	Pt1	41.4	48.0	58.2	62.3	88.2	104	116	132	151	161	167	179	236	250	320	339
160	Pt1	39.9	46.6	55.2	60.6	84.2	101	110	129	146	156	162	173	228	243	311	325
180	Pt1	38.5	44.5	53.0	58.9	81.6	98.1	107	125	145	151	160	168	220	237	312	319
200	Pt1	37.0	42.8	51.3	55.6	77.2	93.9	105	119	142	149	156	166	215	228	298	319
224	Pt1	34.9	41.1	49.4	53.4	74.3	90.8	101	115	133	147	147	162	208	221	289	305
250	Pt1	33.4	39.8	47.1	51.8	70.6	85.7	95.9	112	125	136	140	151	197	213	272	291
280	Pt1	32.3	37.3	45.8	49.7	67.9	82.5	92.9	106	122	129	136	144	190	202	262	274
315	Pt1	31.7	35.8	43.7	47.4	66.2	78.2	89.0	102	116	124	130	140	186	195	251	264
355	Pt1	30.2	34.7	42.8	46.1	63.0	75.3	85.0	98.8	114	120	126	134	176	191	240	254
400	Pt1	-	34.1	-	44.0	-	73.4	-	95.1	-	117	-	131	-	181	-	243
450	Pt1	-	32.3	-	43.1	-	69.9	-	90.6	-	-	-	-	-	-	-	-

Pt1 (kW) İlave soğutmasız redüktörler **)

**) Değerlere Bakınız:

Saatlik Çalışma döngüsü: %100
Büyük bir alanda kurulum
Rakım 1000m'ye kadar

Pt1(kW)Gear units without auxiliary cooling**)

**) Values refer to:

Operating cycle: 100%
Installation in a large hall
Altitude up to 1000 m

Pt1 (kW) Getriebe ohne Zusatzkühlung**)

**) Werte gelten für:

Einschaltdauer: 100 %
Aufstellung in großer Halle
Höhenlage bis 1000 m

TR TERMAL KAPASİTELER Pt (kW)

EN THERMAL CAPACITIES Pt (kW)

DE WÄRMEGRENZLEISTUNGEN Pt (kW)

İN	Pt (kW)	Redüktör Gövdeleri / Gear unit sizes / Getriebegrößen															
		74	84	94	104	114	124	134	144	154	164	174	184	194	204	214	224
100	Pt1	49.7	-	69.0	-	101	-	133	-	175	-	194	-	269	-	355	-
112	Pt1	48.0	-	66.4	-	101	-	132	-	170	183	190	202	264	282	359	365
125	Pt1	46.7	53.6	64.4	69.7	97.4	112	129	145	166	177	185	196	259	273	355	366
140	Pt1	44.4	51.5	62.5	66.9	94.7	112	125	142	161	172	180	192	253	268	343	363
160	Pt1	42.7	50.1	59.2	65.0	90.3	108	118	138	156	167	174	186	245	260	334	349
180	Pt1	41.2	47.6	56.9	63.1	87.5	105	115	135	155	162	172	181	237	254	336	342
200	Pt1	39.7	46.0	55.1	59.7	82.9	101	112	129	152	160	167	179	231	245	320	342
224	Pt1	37.4	44.1	53.0	57.3	79.7	97.4	108	123	143	157	157	173	223	238	309	327
250	Pt1	35.8	42.7	50.6	55.6	75.7	92.0	102	120	135	146	150	162	212	228	293	311
280	Pt1	34.7	40.1	49.2	53.3	72.8	88.5	99.7	114	131	138	146	154	203	217	282	295
315	Pt1	34.0	38.4	46.8	50.9	71.1	83.8	95.6	110	124	134	139	150	199	208	269	284
355	Pt1	32.4	37.2	46.0	49.5	67.6	80.8	91.2	106	122	129	136	144	190	204	257	272
400	Pt1	-	36.5	-	47.1	-	78.8	-	102	-	125	-	141	-	194	-	260
450	Pt1	-	34.7	-	46.3	-	75.0	-	97.2	-	-	-	-	-	-	-	-

İN	Pt (kW)	Redüktör Gövdeleri / Gear unit sizes / Getriebegrößen															
		74	84	94	104	114	124	134	144	154	164	174	184	194	204	214	224
100	Pt1	52.1	-	72.1	-	104	-	137	-	177	-	195	-	268	-	342	-
112	Pt1	50.5	-	69.6	-	105	-	136	-	174	187	193	205	267	285	356	358
125	Pt1	49.1	56.3	67.6	73.1	102	117	134	150	171	183	190	201	264	278	357	365
140	Pt1	46.8	54.3	65.8	70.4	99.2	117	131	148	168	179	187	198	260	276	350	368
160	Pt1	45.1	52.7	62.3	68.4	94.9	113	124	145	163	174	182	194	254	270	343	357
180	Pt1	43.6	50.4	60.1	66.6	92.2	110	121	142	163	170	181	189	248	266	349	355
200	Pt1	42.0	48.7	58.2	63.1	87.5	106	118	136	160	168	176	188	243	258	336	359
224	Pt1	39.7	46.6	56.1	60.7	84.4	103	114	131	151	166	166	184	237	252	327	347
250	Pt1	37.8	45.2	53.6	58.9	80.1	97.3	108	128	143	154	158	171	224	242	310	329
280	Pt1	36.7	42.4	52.0	56.4	77.1	93.6	105	120	139	146	154	163	215	230	298	312
315	Pt1	36.0	40.6	49.6	53.9	75.2	88.7	101	116	132	142	147	158	211	220	286	300
355	Pt1	34.3	39.4	48.7	52.3	71.5	85.5	96.5	112	130	137	144	152	201	216	272	289
400	Pt1	-	38.7	-	49.9	-	83.4	-	107	-	133	-	149	-	205	-	275
450	Pt1	-	36.7	-	49.0	-	79.4	-	102	-	-	-	-	-	-	-	-

Pt1 (kW) İlave soğutmasız redüktörler **)

** Değerlere Bakınız:

Saatlik çalışma döngüsü: %100
Büyük bir alanda kurulum
Rakım 1000m'ye kadar

Pt1 (kW) Gear units without auxiliary cooling**)

** Values refer to:

Operating cycle: 100%
Installation in a large hall
Altitude up to 1000 m

Pt1 (kW) Getriebe ohne Zusatzkühlung**)

** Werte gelten für:

Einschaltdauer: 100 %
Aufstellung in großer Halle
Höhenlage bis 1000 m

TR NOMİNAL GÜÇ DEĞERLERİ P_{2N} (kW)EN NOMINAL POWER RATINGS P_{2N} (kW)DE NENNLEISTUNGEN P_{2N} (kW)

iN	n1 min ⁻¹	n2 min ⁻¹	Redüktör Gövdeleri / Gear unit sizes / Getriebegrößen																		
			42	52	62	72	82	92	102	112	122	132	142	152	162	172	182	192	202	212	222
5.0	1800	360	234	361	-	730	-	1150	-	1769*	-	2637*	-	4690*	-	-	-	-	-	-	-
	1500	300	195	301	-	608	-	958	-	1474	-	2197	-	3909*	-	-	-	-	-	-	-
	1200	240	156	241	-	487	-	766	-	1179	-	1757	-	3126*	-	-	-	-	-	-	-
	1000	200	130	200	-	405	-	639	-	982	-	1465	-	2605	-	-	-	-	-	-	-
5.6	1800	321	212	321	-	651	-	1025	-	1648*	-	2386*	-	4182*	4628*	-	-	-	-	-	-
	1500	268	176	268	-	544	-	856	-	1376	-	1992	-	3491*	3864*	-	-	-	-	-	-
	1200	214	141	214	-	434	-	683	-	1099	-	1590	-	2788*	3086*	4456*	-	-	-	-	-
	1000	179	118	180	-	363	-	571	-	919	-	1330	-	2332	2581	3727*	-	-	-	-	-
6.3	1800	286	189	287	366	580	726	913	1161	1533*	1795	2254*	2602*	3971*	4306*	-	-	-	-	-	-
	1500	238	157	239	305	482	605	760	966	1276	1494	1876	2165	3304*	3583*	4956*	-	-	-	-	-
	1200	190	125	191	243	386	482	606	771	1018	1192	1497	1729	2638*	2861*	3957*	-	-	-	-	-
	1000	159	105	159	203	322	404	507	645	852	998	1253	1446	2207	2394	3311*	-	-	-	-	-
7.1	1800	254	167	255	325	515	646	811	1030	1421*	1651	2058*	2367*	3580*	3933*	-	-	-	-	-	-
	1500	211	139	211	270	427	536	673	856	1180	1372	1710	1967	2974*	3267*	4394*	-	-	-	-	-
	1200	169	111	169	216	343	429	540	685	946	1099	1370	1575	2382*	2616*	3519*	4151*	-	-	-	-
	1000	141	93.0	141	181	286	358	450	572	788	917	1142	1314	1987	2183	2937	3463*	-	-	-	-
8.0	1800	225	149	225	288	456	571	718	913	1297	1516	1922*	2198*	3171*	3556*	4686*	-	-	-	-	-
	1500	188	124	189	241	381	477	600	763	1084	1267	1605	1837	2650	2971*	3915*	4618*	-	-	-	-
	1200	150	99.0	150	192	304	380	478	608	865	1011	1281	1466	2114	2370*	3123*	3684*	-	-	-	-
	1000	125	83.0	125	160	253	317	399	507	720	842	1068	1221	1762	1976	2603	3070	-	-	-	-
9.0	1800	200	132	200	256	405	508	639	811	1153	1392	1732*	2021*	2819*	3161*	4165*	4912*	-	-	-	-
	1500	167	110	167	213	339	424	532	677	963	1163	1446	1687	2354	2640	3477*	4101*	-	-	-	-
	1200	133	88.0	133	170	269	338	424	540	767	926	1152	1343	1875	2102	2769*	3267*	-	-	-	-
	1000	111	73.0	111	142	224	282	354	450	640	772	961	1121	1565	1754	2311	2726	-	-	-	-
10.0	1800	180	118	181	231	365	457	574	730	1037	1274	1559*	1899*	2537*	2845*	3749*	4422*	-	-	-	-
	1500	150	99.0	150	192	304	380	478	608	865	1062	1298	1582	2114	2370	3123*	3684*	-	-	-	-
	1200	120	79.0	120	153	243	305	383	487	692	850	1039	1266	1691	1896	2499*	2948*	-	-	-	-
	1000	100	65.0	100	128	202	254	319	405	576	708	866	1055	1410	1580	2082	2456	-	-	-	-
11.2	1800	161	106	161	206	326	409	514	653	928	1139	1394*	1743*	2270*	2545*	3353*	3955*	-	-	-	-
	1500	134	88.0	134	171	271	340	427	544	772	949	1160	1450	1889	2118	2791*	3292*	-	-	-	-
	1200	107	70.0	107	137	216	271	342	434	617	757	926	1159	1508	1691	2228*	2628*	-	-	-	-
	1000	89.0	58.0	89.0	113	181	225	284	361	513	629	770	963	1255	1407	1853	2186	-	-	-	-
12.5	1800	144	-	-	184	-	365	-	583	-	1019	-	1559*	-	2276*	-	3537*	-	-	-	-
	1500	120	-	-	153	-	305	-	487	-	850	-	1299	-	1896	-	2948	-	-	-	-
	1200	96.0	-	-	122	-	244	-	389	-	679	-	1039	-	1517	-	2358	-	-	-	-
	1000	80.0	-	-	102	-	203	-	324	-	566	-	866	-	1264	-	1965	-	-	-	-
14.0	1800	129	-	-	165	-	327	-	523	-	913	-	1396*	-	-	-	-	-	-	-	-
	1500	107	-	-	137	-	271	-	434	-	757	-	1159	-	-	-	-	-	-	-	-
	1200	86.0	-	-	110	-	218	-	349	-	609	-	931	-	-	-	-	-	-	-	-
	1000	71.0	-	-	91.0	-	180	-	288	-	502	-	768	-	-	-	-	-	-	-	-

■ Yatay redüktörlerde basınçlı yağlama gereklidir.

■ Forced lubrication required on horizontal gear units

■ Druckschmierung bei Horizontalgetrieben erforderlich

☒ Talep edildiğinde yapılan redüktörler.

☒ Gear units only on request

☒ Getriebe nur auf Anfrage

TR NOMİNAL ÇIKIŞ MOMENTLERİ T_{2N} (kNm)

EN NOMINAL OUTPUT TORQUES T_{2N} (kNm)

DE NENN-ABTRIEBSDREHMOMENTE T_{2N} (kNm)

İN	Redüktör Gövdeleri / Gear unit sizes / Getriebegrößen																		
	42	52	62	72	82	92	102	112	122	132	142	152	162	172	182	192	202	212	222
5.0	6.2	9.6	-	19.4	-	30.5	-	46.9	-	70.0	-	124	-	-	-	-	-	-	-
5.6	6.3	9.6	-	19.4	-	30.5	-	49.1	-	71.0	-	124	138	199	-	-	-	-	-
6.3	6.3	9.6	12.2	19.4	24.3	30.5	38.8	51.2	60.0	75.3	86.9	133	144	199	-	-	-	-	-
7.1	6.3	9.6	12.2	19.4	24.3	30.5	38.8	53.4	62.1	77.4	89.0	135	148	199	235	-	-	-	-
8.0	6.3	9.6	12.2	19.4	24.3	30.5	38.8	55.1	64.4	81.6	93.3	135	151	199	235	-	-	-	-
9.0	6.3	9.6	12.2	19.4	24.3	30.5	38.8	55.1	66.5	82.7	96.5	135	151	199	235	-	-	-	-
10.0	6.3	9.6	12.2	19.4	24.3	30.5	38.8	55.1	67.6	82.7	101	135	151	199	235	-	-	-	-
11.2	6.3	9.6	12.2	19.4	24.3	30.5	38.8	55.1	67.6	82.7	103	135	151	199	235	-	-	-	-
12.5	-	-	12.2	-	24.3	-	38.8	-	67.6	-	103	-	151	-	235	-	-	-	-
14.0	-	-	12.2	-	24.3	-	38.8	-	67.6	-	103	-	-	-	-	-	-	-	-

TR TERMAL KAPASİTELER Pt (kW)

EN THERMAL CAPACITIES Pt (kW)

DE WÄRMEGRENZLEISTUNGEN Pt (kW)

iN	Pt (kW)	Redüktör Gövdeleri / Gear unit sizes / Getriebegrößen																n ₁ =1000 min ⁻¹			
		42	52	62	72	82	92	102	112	122	132	142	152	162	172	182	192	202	212	222	
5.0	Pt1	49.3	59.8	-	78.9	-	88.8	-	*	-	*	-	*	-	-	-	-	-	-	-	
	Pt2	115	158	-	251	-	303	-	497	-	698	-	804	-	-	-	-	-	-	-	
	Pt3	140	210	-	325	-	406	-	691	-	1371	-	1857	-	-	-	-	-	-	-	
	Pt4	198	297	-	477	-	590	-	1004	-	1875	-	2431	-	-	-	-	-	-	-	
5.6	Pt1	48.7	61.0	-	79.9	-	92.0	-	122	-	*	-	*	-	*	-	-	-	-	-	
	Pt2	111	156	-	237	-	288	-	491	-	702	-	820	-	876	-	-	-	-	-	
	Pt3	135	203	-	299	-	374	-	656	-	1315	-	1798	-	2096	-	-	-	-	-	
	Pt4	191	288	-	441	-	546	-	962	-	1825	-	2380	-	2743	-	-	-	-	-	
6.3	Pt1	47.9	59.9	69.7	77.3	91.7	91.2	100	124	145	*	*	*	*	*	-	-	-	-	-	
	Pt2	107	148	173	220	266	270	306	450	567	650	786	795	855	867	-	-	-	-	-	
	Pt3	129	189	269	271	396	340	469	577	996	1155	1439	1660	1818	1947	-	-	-	-	-	
	Pt4	183	268	366	401	559	499	656	851	1367	1605	1993	2211	2413	2581	-	-	-	-	-	
7.1	Pt1	45.9	58.3	70.4	75.8	90.7	90.9	101	135	161	154	180	*	*	*	*	-	-	-	-	
	Pt2	101	140	169	207	251	255	290	445	557	650	783	771	831	855	915	-	-	-	-	
	Pt3	118	174	262	249	364	312	430	556	950	1119	1379	1538	1678	1823	1957	-	-	-	-	
	Pt4	167	248	356	369	516	460	606	824	1304	1572	1933	2069	2248	2434	2609	-	-	-	-	
8.0	Pt1	43.7	55.9	68.5	73.5	87.8	89.1	99.7	132	158	157	185	*	*	*	*	-	-	-	-	
	Pt2	94.8	131	160	196	234	242	272	408	508	600	719	719	800	809	891	-	-	-	-	
	Pt3	109	160	242	231	329	289	391	492	833	998	1209	1383	1562	1653	1829	-	-	-	-	
	Pt4	155	230	330	343	468	427	552	733	1152	1403	1696	1867	2100	2217	2450	-	-	-	-	
9.0	Pt1	41.8	53.8	65.8	71.6	84.4	87.5	97.2	132	165	162	197	172	180	*	*	-	-	-	-	
	Pt2	89.6	123	151	186	219	231	256	391	500	576	713	698	745	789	839	-	-	-	-	
	Pt3	101	147	222	216	303	272	359	463	807	932	1175	1309	1395	1573	1656	-	-	-	-	
	Pt4	144	210	305	322	432	404	510	693	1116	1322	1658	1776	1890	2120	2232	-	-	-	-	
10.0	Pt1	35.3	50.3	62.3	67.7	80.8	83.5	93.5	128	156	160	192	175	186	179	*	-	-	-	-	
	Pt2	74.3	113	141	172	206	216	242	366	456	546	655	656	718	752	815	-	-	-	-	
	Pt3	80.5	132	204	196	279	249	332	425	714	863	1038	1193	1322	1460	1577	-	-	-	-	
	Pt4	114	189	282	294	400	370	471	639	991	1224	1473	1628	1795	1974	2127	-	-	-	-	
11.2	Pt1	34.2	45.3	59.6	61.0	77.6	76.0	90.8	116	153	148	189	165	185	172	191	-	-	-	-	
	Pt2	71.7	101	134	153	196	191	231	324	435	486	625	593	675	682	775	-	-	-	-	
	Pt3	76.9	115	187	171	262	216	313	368	672	749	971	1051	1206	1292	1468	-	-	-	-	
	Pt4	109	165	257	257	375	322	447	554	936	1067	1383	1439	1648	1754	1979	-	-	-	-	
12.5	Pt1	-	-	55.6	-	73.6	-	86.8	-	148	-	187	-	179	-	190	-	-	-	-	
	Pt2	-	-	121	-	183	-	216	-	408	-	591	-	610	-	705	-	-	-	-	
	Pt3	-	-	166	-	239	-	286	-	616	-	900	-	1060	-	1302	-	-	-	-	
	Pt4	-	-	230	-	344	-	409	-	862	-	1280	-	1459	-	1765	-	-	-	-	
14.0	Pt1	-	-	50.0	-	66.5	-	78.5	-	134	-	171	-	-	-	-	-	-	-	-	
	Pt2	-	-	108	-	162	-	193	-	360	-	524	-	-	-	-	-	-	-	-	
	Pt3	-	-	145	-	209	-	248	-	532	-	778	-	-	-	-	-	-	-	-	
	Pt4	-	-	200	-	299	-	355	-	748	-	1114	-	-	-	-	-	-	-	-	

[*] Talep edildiğinde

- A) Değerler aşağıda belirtilen şartlar için geçerlidir:
Saatlik çalışma döngüsü: %100
Büyük bir alanda kurulum rakım 1000 m'ye kadar
- B) Değerler aşağıda belirtilen şartlar için geçerlidir:
Soğutma suyu, çıkış su sıcaklığı ne olursa olsun, soğuk su giriş sıcaklığı 20°C olmalıdır.
Soğutma suyu çıkış sıcaklığının sınırlanmasına ilişkin hesaplama, ancak talep edildiğinde sağlanır.

[*] On request

- A) Values refer to:
Operating cycle: 100%
Installation in a large hall Altitude up to 1000 m
- B) Values refer to:
A cooling water inlet temperature of 20°C with unlimited cooling water outlet temperature.
A recalculation with a limited cooling water outlet temperature is possible on request.

[*] Auf Anfrage

- A) Werte gelten für:
Einschaltdauer: 100%
Aufstellung in großer Halle Höhenlage bis 1000 m
- B) Werte gelten für:
Eine Kühlwassereintrittstemperatur von 20°C ohne Begrenzung der Kühlwasseraustrittstemperatur.
Die Nachrechnung mit Begrenzung der Kühlwasser austrittstemperatur ist auf Anfrage möglich.

Pt1 Redüktörler, ilave soğutucusu yok. A

Pt2 Redüktörler, fan soğutucusu. A

Pt3 Redüktörler, monte edilmiş serpantinli soğutucu. A,B

Pt4 Redüktörler, fanlı ve monte edilmiş serpantinli soğutucu. A,B

Pt1 Gear units without auxiliary cooling A

Pt2 Gear units with fan A

Pt3 Gear units with built-in cooling coil A,B

Pt4 Gear units with fan and built-in cooling coil A,B

Pt1 Getriebe ohne Zusatzkühlung A

Pt2 Getriebe mit Lüfterkühlung A

Pt3 Getriebe mit eingebauter Kühlschlange A,B

Pt4 Getriebe mit Lüfter und eingebauter Kühlschlange A,B

TR TERMAL KAPASİTELER Pt (kW)

EN THERMAL CAPACITIES Pt (kW)

DE WÄRMEGRENZLEISTUNGEN Pt (kW)

İN	Pt (kW)	Redüktör Gövdeleri / Gear unit sizes / Getriebegrößen																n ₁ =1200 min ⁻¹			
		42	52	62	72	82	92	102	112	122	132	142	152	162	172	182	192	202	212	222	
5.0	Pt1	48.1	54.5	-	67.3	-	*	-	*	-	*	-	*	-	-	-	-	-	-	-	
	Pt2	135	182	-	282	-	332	-	510	-	658	-	653	-	-	-	-	-	-	-	
	Pt3	156	233	-	360	-	450	-	759	-	1496	-	2007	-	-	-	-	-	-	-	
	Pt4	233	345	-	549	-	670	-	1107	-	1992	-	2438	-	-	-	-	-	-	-	
5.6	Pt1	48.5	57.6	-	72.2	-	77.3	-	*	-	*	-	*	-	*	-	-	-	-	-	
	Pt2	131	181	-	270	-	322	-	522	-	703	-	738	-	732	-	-	-	-	-	
	Pt3	150	226	-	333	-	414	-	723	-	1442	-	1956	-	2268	-	-	-	-	-	
	Pt4	225	337	-	511	-	626	-	1079	-	1989	-	2483	-	2781	-	-	-	-	-	
6.3	Pt1	48.2	57.7	66.4	71.9	83.0	80.2	85.5	*	*	*	*	*	*	*	-	-	-	-	-	
	Pt2	128	172	201	254	304	307	344	490	603	670	805	755	794	777	-	-	-	-	-	
	Pt3	144	210	299	301	440	377	520	638	1098	1270	1582	1814	1983	2118	-	-	-	-	-	
	Pt4	216	314	427	467	649	577	755	963	1530	1775	2193	2357	2549	2686	-	-	-	-	-	
7.1	Pt1	46.7	57.5	68.9	72.8	85.5	84.0	91.6	110	*	*	*	*	*	*	*	-	-	-	-	
	Pt2	119	164	198	242	291	294	332	495	610	697	833	777	825	827	866	-	-	-	-	
	Pt3	132	194	292	277	405	347	477	616	1050	1235	1521	1688	1839	1993	2138	-	-	-	-	
	Pt4	198	292	418	432	602	536	703	944	1480	1768	2166	2262	2442	2614	2777	-	-	-	-	
8.0	Pt1	44.8	55.9	68.0	72.0	84.7	84.7	93.0	114	130	*	*	*	*	*	*	-	-	-	-	
	Pt2	112	154	189	230	272	279	314	460	566	656	782	750	823	816	885	-	-	-	-	
	Pt3	121	179	269	257	366	321	435	546	922	1103	1335	1523	1717	1816	2004	-	-	-	-	
	Pt4	185	270	390	403	550	500	644	847	1319	1593	1922	2073	2318	2426	2660	-	-	-	-	
9.0	Pt1	43.1	54.3	66.1	71.1	82.7	84.9	92.9	118	143	133	*	*	*	*	*	-	-	-	-	
	Pt2	107	147	180	218	258	269	298	446	565	643	791	747	788	823	864	-	-	-	-	
	Pt3	112	164	248	241	338	303	400	515	895	1033	1301	1443	1538	1731	1822	-	-	-	-	
	Pt4	170	249	360	380	508	474	597	804	1286	1514	1894	1995	2114	2354	2462	-	-	-	-	
10.0	Pt1	36.5	51.1	63.0	67.8	80.1	81.9	90.7	117	140	137	160	*	*	*	*	-	-	-	-	
	Pt2	88.8	135	167	203	243	254	283	421	518	613	733	712	774	799	856	-	-	-	-	
	Pt3	89.9	147	228	218	311	277	369	472	793	957	1152	1319	1460	1609	1737	-	-	-	-	
	Pt4	137	223	333	347	471	435	553	744	1149	1409	1691	1842	2024	2210	2368	-	-	-	-	
11.2	Pt1	35.5	46.2	60.5	61.4	77.4	75.1	88.7	108	139	130	163	*	*	*	*	-	-	-	-	
	Pt2	86.0	120	158	181	232	224	270	374	498	550	705	650	734	734	825	-	-	-	-	
	Pt3	85.9	129	208	191	292	241	348	409	748	830	1077	1162	1332	1427	1619	-	-	-	-	
	Pt4	131	196	304	304	443	379	524	646	1087	1232	1594	1637	1868	1977	2219	-	-	-	-	
12.5	Pt1	-	-	56.8	-	74.2	-	86.0	-	138	-	167	-	*	-	*	-	-	-	-	
	Pt2	-	-	145	-	216	-	255	-	471	-	672	-	674	-	765	-	-	-	-	
	Pt3	-	-	186	-	266	-	318	-	685	-	999	-	1173	-	1437	-	-	-	-	
	Pt4	-	-	272	-	406	-	481	-	1005	-	1483	-	1665	-	1996	-	-	-	-	
14.0	Pt1	-	-	51.3	-	67.4	-	78.4	-	128	-	157	-	-	-	-	-	-	-	-	
	Pt2	-	-	130	-	193	-	227	-	417	-	601	-	-	-	-	-	-	-	-	
	Pt3	-	-	162	-	233	-	276	-	592	-	865	-	-	-	-	-	-	-	-	
	Pt4	-	-	237	-	354	-	419	-	873	-	1295	-	-	-	-	-	-	-	-	

☐ * Talep edildiğinde

- A)** Değerler aşağıda belirtilen şartlar için geçerlidir:
Saatlik çalışma döngüsü: %100
Büyük bir alanda kurulum rakım 1000 m'ye kadar
- B)** Değerler aşağıda belirtilen şartlar için geçerlidir:
Soğutma suyu, çıkış su sıcaklığı ne olursa olsun, soğuk su giriş sıcaklığı 20°C olmalıdır.
Soğutma suyu çıkış sıcaklığının sınırlanmasına ilişkin hesaplama, ancak talep edildiğinde sağlanır.

☐ * On request

- A)** Values refer to:
Operating cycle: 100%
Installation in a large hall Altitude up to 1000 m
- B)** Values refer to:
A cooling water inlet temperature of 20°C with unlimited cooling water outlet temperature.
A recalculation with a limited cooling water outlet temperature is possible on request.

☐ * Auf Anfrage

- A)** Werte gelten für:
Einschaltdauer: 100%
Aufstellung in großer Halle Höhenlage bis 1000 m
- B)** Werte gelten für:
Eine Kühlwassereintrittstemperatur von 20°C ohne Begrenzung der Kühlwasseraustrittstemperatur.
Die Nachrechnung mit Begrenzung der Kühlwasser austrittstemperatur ist auf Anfrage möglich.

Pt1 Redüktörler, ilave soğutucusu yok. **A**

Pt2 Redüktörler, fan soğutuculu. **A**

Pt3 Redüktörler, monte edilmiş serpantinli soğutucu. **A,B**

Pt4 Redüktörler, fanlı ve monte edilmiş serpantinli soğutucu. **A,B**

Pt1 Gear units without auxiliary cooling **A**

Pt2 Gear units with fan **A**

Pt3 Gear units with built-in cooling coil **A,B**

Pt4 Gear units with fan and built-in cooling coil **A,B**

Pt1 Getriebe ohne Zusatzkühlung **A**

Pt2 Getriebe mit Lüfterkühlung **A**

Pt3 Getriebe mit eingebauter Kühlschlange **A,B**

Pt4 Getriebe mit Lüfter und eingebauter Kühlschlange **A,B**

TR TERMAL KAPASİTELER Pt (kW)

EN THERMAL CAPACITIES Pt (kW)

DE WÄRMEGRENZLEISTUNGEN Pt (kW)

iN	Pt (kW)	Redüktör Gövdeleri / Gear unit sizes / Getriebegrößen																	n ₁ =1500 min ⁻¹			
		42	52	62	72	82	92	102	112	122	132	142	152	162	172	182	192	202	212	222		
5.0	Pt1	36.0	*	-	*	-	*	-	*	-	*	-	*	-	*	-	*	-	*	-		
	Pt2	142	188	-	289	-	335	-	488	-	585	-	496	-	-	-	-	-	-	-		
	Pt3	162	243	-	375	-	468	-	789	-	1554	-	2081	-	-	-	-	-	-	-		
	Pt4	254	373	-	593	-	719	-	1167	-	2059	-	2434	-	-	-	-	-	-	-		
5.6	Pt1	39.4	*	-	*	-	*	-	*	-	*	-	*	-	*	-	*	-	*	-		
	Pt2	138	189	-	279	-	328	-	514	-	659	-	630	-	576	-	-	-	-	-		
	Pt3	157	236	-	347	-	432	-	753	-	1499	-	2032	-	2353	-	-	-	-	-		
	Pt4	246	366	-	554	-	675	-	1149	-	2085	-	2539	-	2794	-	-	-	-	-		
6.3	Pt1	40.8	*	*	*	*	*	*	*	*	*	*	*	*	*	*	*	*	*	*		
	Pt2	135	182	210	264	314	316	352	489	593	646	768	677	698	659	-	-	-	-			
	Pt3	150	219	312	314	458	393	542	664	1142	1321	1645	1884	2059	2198	-	-	-	-			
	Pt4	236	343	465	507	704	624	815	1030	1628	1876	2312	2441	2625	2743	-	-	-	-			
7.1	Pt1	41.4	44.9	51.6	*	*	*	*	*	*	*	*	*	*	*	*	*	*	*	*		
	Pt2	128	172	208	253	304	305	343	503	613	690	820	734	769	755	775	-	-	-			
	Pt3	138	203	304	290	422	361	498	642	1093	1286	1583	1756	1913	2072	2221	-	-	-			
	Pt4	217	319	456	471	655	581	762	1016	1587	1885	2306	2378	2555	2719	2873	-	-	-			
8.0	Pt1	40.7	46.0	54.5	54.1	*	*	*	*	*	*	*	*	*	*	*	*	*	*	*		
	Pt2	119	163	199	241	286	293	327	472	575	659	783	727	791	771	824	-	-	-			
	Pt3	126	186	282	268	383	335	453	568	961	1149	1391	1584	1786	1888	2084	-	-	-			
	Pt4	202	296	425	439	598	544	700	914	1420	1707	2056	2195	2448	2549	2784	-	-	-			
9.0	Pt1	40.1	46.6	55.5	56.9	62.8	60.8	*	*	*	*	*	*	*	*	*	*	*	*	*		
	Pt2	113	156	190	231	271	283	312	461	579	653	801	738	774	798	828	-	-	-			
	Pt3	117	171	258	251	353	316	417	537	933	1076	1356	1503	1601	1801	1895	-	-	-			
	Pt4	187	272	394	415	554	517	650	870	1390	1630	2036	2127	2248	2493	2600	-	-	-			
10.0	Pt1	34.4	44.9	54.4	56.2	63.5	62.0	65.2	*	*	*	*	*	*	*	*	*	*	*	*		
	Pt2	94.7	143	177	215	256	266	297	438	536	628	749	712	768	785	834	-	-	-			
	Pt3	93.7	153	238	228	324	290	385	493	826	998	1200	1374	1520	1675	1807	-	-	-			
	Pt4	150	245	363	379	515	474	603	807	1242	1520	1823	1972	2160	2352	2513	-	-	-			
11.2	Pt1	33.7	41.2	53.1	52.0	63.1	58.9	66.5	*	*	*	*	*	*	*	*	*	*	*	*		
	Pt2	91.6	128	168	192	245	237	285	390	516	566	723	654	735	728	813	-	-	-			
	Pt3	89.7	134	217	199	304	251	363	426	779	866	1123	1210	1387	1486	1685	-	-	-			
	Pt4	143	214	334	333	483	414	572	702	1179	1332	1722	1756	1999	2109	2361	-	-	-			
12.5	Pt1	-	-	51.1	-	62.9	-	68.2	-	*	-	*	-	*	-	*	-	*	-	-		
	Pt2	-	-	154	-	228	-	269	-	491	-	695	-	682	-	764	-	-	-	-		
	Pt3	-	-	193	-	277	-	333	-	715	-	1041	-	1222	-	1497	-	-	-	-		
	Pt4	-	-	298	-	444	-	525	-	1091	-	1605	-	1789	-	2135	-	-	-	-		
14.0	Pt1	-	-	46.9	-	58.5	-	64.4	-	*	-	*	-	-	-	-	-	-	-	-		
	Pt2	-	-	138	-	204	-	241	-	437	-	623	-	-	-	-	-	-	-	-		
	Pt3	-	-	169	-	243	-	289	-	617	-	902	-	-	-	-	-	-	-	-		
	Pt4	-	-	260	-	388	-	458	-	950	-	1405	-	-	-	-	-	-	-	-		

[*] Talep edildiğinde

- A) Değerler aşağıda belirtilen şartlar için geçerlidir:
Saatlik çalışma döngüsü: %100
Büyük bir alanda kurulum rakım 1000 m'ye kadar
- B) Değerler aşağıda belirtilen şartlar için geçerlidir:
Soğutma suyu, çıkış su sıcaklığı ne olursa olsun, soğuk su giriş sıcaklığı 20°C olmalıdır.
Soğutma suyu çıkış sıcaklığının sınırlanmasına ilişkin hesaplama, ancak talep edildiğinde sağlanır.

[*] On request

- A) Values refer to:
Operating cycle: 100%
Installation in a large hall Altitude up to 1000 m
- B) Values refer to:
A cooling water inlet temperature of 20°C with unlimited cooling water outlet temperature.
A recalculation with a limited cooling water outlet temperature is possible on request.

[*] Auf Anfrage

- A) Werte gelten für:
Einschaltdauer: 100%
Aufstellung in großer Halle Höhenlage bis 1000 m
- B) Werte gelten für:
Eine Kühlwassereintrittstemperatur von 20°C ohne Begrenzung der Kühlwasseraustrittstemperatur.
Die Nachrechnung mit Begrenzung der Kühlwasser austrittstemperatur ist auf Anfrage möglich.

Pt1 Redüktörler, ilave soğutucusu yok. A

Pt2 Redüktörler, fan soğutucusu. A

Pt3 Redüktörler, monte edilmiş serpantinli soğutucu. A,B

Pt4 Redüktörler, fanlı ve monte edilmiş serpantinli soğutucu. A,B

Pt1 Gear units without auxiliary cooling A

Pt2 Gear units with fan A

Pt3 Gear units with built-in cooling coil A,B

Pt4 Gear units with fan and built-in cooling coil A,B

Pt1 Getriebe ohne Zusatzkühlung A

Pt2 Getriebe mit Lüfterkühlung A

Pt3 Getriebe mit eingebauter Kühlschlange A,B

Pt4 Getriebe mit Lüfter und eingebauter Kühlschlange A,B

TR TERMAL KAPASİTELER Pt (kW)

EN THERMAL CAPACITIES Pt (kW)

DE WÄRMEGRENZLEISTUNGEN Pt (kW)

İN	Pt (kW)	Redüktör Gövdeleri / Gear unit sizes / Getriebegrößen																	n ₁ =1800 min ⁻¹			
		42	52	62	72	82	92	102	112	122	132	142	152	162	172	182	192	202	212	222		
5.0	Pt1	*	*	-	*	-	*	-	*	-	*	-	*	-	*	-	*	-	*	-		
	Pt2	152	194	-	289	-	319	-	400	-	357	-	*	-	*	-	*	-	*	-		
	Pt3	173	255	-	391	-	479	-	780	-	1475	-	1850	-	-	-	-	-	-	-		
	Pt4	282	409	-	643	-	768	-	1197	-	2005	-	2146	-	-	-	-	-	-	-		
5.6	Pt1	*	*	-	*	-	*	-	*	-	*	-	*	-	*	-	*	-	*	-		
	Pt2	150	198	-	288	-	327	-	462	-	503	-	*	-	*	-	*	-	*	-		
	Pt3	167	249	-	363	-	448	-	759	-	1464	-	1888	-	2117	-	-	-	-	-		
	Pt4	273	403	-	605	-	730	-	1206	-	2107	-	2402	-	2513	-	-	-	-	-		
6.3	Pt1	31.6	*	*	*	*	*	*	*	*	*	*	*	*	*	-	-	-	-	-		
	Pt2	147	193	222	275	324	321	353	459	529	539	624	427	*	*	-	-	-	-			
	Pt3	160	233	330	330	480	410	562	676	1150	1311	1624	1793	1940	2037	-	-	-	-			
	Pt4	263	378	514	557	769	679	882	1094	1706	1932	2368	2389	2532	2584	-	-	-	-			
7.1	Pt1	34.7	*	*	*	*	*	*	*	*	*	*	*	*	*	*	-	-	-	-		
	Pt2	139	186	223	268	319	317	353	495	583	628	735	574	571	513	482	-	-	-			
	Pt3	148	216	323	307	446	379	522	663	1119	1301	1595	1721	1859	1990	2111	-	-	-			
	Pt4	243	354	505	521	721	638	833	1094	1692	1985	2418	2414	2569	2692	2806	-	-	-			
8.0	Pt1	35.7	*	*	*	*	*	*	*	*	*	*	*	*	*	*	-	-	-	-		
	Pt2	132	176	215	258	304	308	343	476	567	628	737	621	654	604	612	-	-	-			
	Pt3	136	199	300	285	405	354	477	592	992	1175	1419	1580	1769	1851	2026	-	-	-			
	Pt4	226	329	473	487	662	600	769	992	1530	1821	2186	2275	2516	2590	2798	-	-	-			
9.0	Pt1	35.7	36.7	*	*	*	*	*	*	*	*	*	*	*	*	*	-	-	-	-		
	Pt2	125	169	206	249	291	301	330	474	585	643	781	671	687	682	684	-	-	-			
	Pt3	125	184	276	268	375	336	442	562	971	1112	1396	1519	1610	1796	1876	-	-	-			
	Pt4	210	304	439	462	615	572	717	952	1510	1755	2187	2239	2352	2584	2671	-	-	-			
10.0	Pt1	31.6	36.7	43.9	*	*	*	*	*	*	*	*	*	*	*	*	-	-	-	-		
	Pt2	104	157	194	234	276	286	316	456	548	629	744	668	708	702	726	-	-	-			
	Pt3	101	164	255	244	346	308	408	518	864	1035	1243	1400	1541	1686	1808	-	-	-			
	Pt4	167	273	406	422	572	526	667	885	1356	1646	1971	2093	2282	2464	2615	-	-	-			
11.2	Pt1	30.6	34.7	43.9	40.8	*	*	*	*	*	*	*	*	*	*	*	-	-	-	-		
	Pt2	101	140	184	208	264	255	305	409	532	573	727	626	693	669	729	-	-	-			
	Pt3	95.9	144	234	213	325	267	387	450	817	903	1168	1239	1415	1506	1697	-	-	-			
	Pt4	160	240	372	370	539	460	634	772	1290	1448	1868	1876	2125	2227	2477	-	-	-			
12.5	Pt1	-	-	43.9	-	49.0	-	*	-	*	-	*	-	*	-	*	-	*	-			
	Pt2	-	-	169	-	249	-	290	-	513	-	711	-	663	-	715	-	-	-			
	Pt3	-	-	207	-	297	-	354	-	753	-	1089	-	1258	-	1524	-	-	-			
	Pt4	-	-	334	-	495	-	584	-	1200	-	1752	-	1920	-	2265	-	-	-			
14.0	Pt1	-	-	40.8	-	47.9	-	*	-	*	-	*	-	*	-	*	-	*	-			
	Pt2	-	-	152	-	222	-	260	-	460	-	646	-	-	-	-	-	-	-			
	Pt3	-	-	182	-	260	-	308	-	653	-	948	-	-	-	-	-	-	-			
	Pt4	-	-	291	-	432	-	510	-	1048	-	1539	-	-	-	-	-	-	-			

* Talep edildiğinde

- A)** Değerler aşağıda belirtilen şartlar için geçerlidir:
Saatlik çalışma döngüsü: %100
Büyük bir alanda kurulum rakım 1000 m'ye kadar
- B)** Değerler aşağıda belirtilen şartlar için geçerlidir:
Soğutma suyu, çıkış su sıcaklığı ne olursa olsun, soğuk su giriş sıcaklığı 20°C olmalıdır.
Soğutma suyu çıkış sıcaklığının sınırlanmasına ilişkin hesaplama, ancak talep edildiğinde sağlanır.

* On request

- A)** Values refer to:
Operating cycle: 100%
Installation in a large hall Altitude up to 1000 m
- B)** Values refer to:
A cooling water inlet temperature of 20°C with unlimited cooling water outlet temperature.
A recalculation with a limited cooling water outlet temperature is possible on request.

* Auf Anfrage

- A)** Werte gelten für:
Einschaltdauer: 100%
Aufstellung in großer Halle Höhenlage bis 1000 m
- B)** Werte gelten für:
Eine Kühlwassereintrittstemperatur von 20°C ohne Begrenzung der Kühlwasseraustrittstemperatur.
Die Nachrechnung mit Begrenzung der Kühlwasser austrittstemperatur ist auf Anfrage möglich.

Pt1 Redüktörler, ilave soğutucusu yok. **A**

Pt2 Redüktörler, fan soğutuculu. **A**

Pt3 Redüktörler, monte edilmiş serpantinli soğutucu. **A,B**

Pt4 Redüktörler, fanlı ve monte edilmiş serpantinli soğutucu. **A,B**

Pt1 Gear units without auxiliary cooling **A**

Pt2 Gear units with fan **A**

Pt3 Gear units with built-in cooling coil **A,B**

Pt4 Gear units with fan and built-in cooling coil **A,B**

Pt1 Getriebe ohne Zusatzkühlung **A**

Pt2 Getriebe mit Lüfterkühlung **A**

Pt3 Getriebe mit eingebauter Kühlschlange **A,B**

Pt4 Getriebe mit Lüfter und eingebauter Kühlschlange **A,B**

TR NÖMİNAL GÜÇ DEĞERLERİ P_{2N} (kW)EN NOMINAL POWER RATINGS P_{2N} (kW)DE NENNLEISTUNGEN P_{2N} (kW)

iN	n1 min-1	n2 min-1	Redüktör Gövdeleri / Gear unit sizes / Getriebegrößen																			
			43	53	63	73	83	93	103	113	123	133	143	153	163	173	183	193	203	213	223	
12.5	1800	144	84.0	144	-	261	-	430	-	806	-	1222	-	2030*	-	2999*	-	3844*	-	-	-	-
	1500	120	70.0	120	-	217	-	358	-	671	-	1018	-	1691	-	2499	-	3204*	-	-	4357*	-
	1200	96.0	56.0	96.0	-	173	-	287	-	537	-	815	-	1353	-	1999	-	2563*	-	-	3485*	-
	1000	80.0	47.0	80.0	-	145	-	239	-	447	-	678	-	1127	-	1666	-	2136	-	-	2905	-
14.0	1800	129	83.0	135	-	250	-	406	-	780	-	1124	-	1887*	2039*	2687*	3168*	3610*	4064*	4959*	-	-
	1500	107	68.0	111	-	207	-	337	-	648	-	932	-	1565	1691	2228	2628	2994*	3371*	4114*	4628*	-
	1200	86.0	55.0	90.0	-	166	-	270	-	520	-	749	-	1258	1359	1791	2112	2406*	2709*	3306*	3720*	-
	1000	71.0	45.0	73.0	-	138	-	223	-	429	-	618	-	1038	1122	1478	1743	1986	2237	2730	3070	-
16.0	1800	113	80.0	126	144	239	259	373	429	722	800	1011	1200	1714*	1858*	2413*	2775*	3318*	3717*	4586*	5093*	-
	1500	94.0	65.0	105	120	198	215	311	357	601	665	840	998	1425	1545	2007	2308	2760*	3092*	3815*	4236*	-
	1200	75.0	52.0	84.0	96.0	158	171	248	285	479	530	671	796	1137	1233	1601	1842	2202*	2466*	3044*	3380*	-
	1000	63.0	44.0	70.0	81.0	133	144	208	239	403	446	563	668	955	1035	1345	1547	1850	2072	2556	2839	-
18.0	1800	100	71.0	120	134	224	246	361	400	662	742	925	1089	1580*	1709*	2136*	2563*	3075*	3417*	4272*	4678*	-
	1500	83.0	59.0	100	111	187	204	300	332	549	616	768	904	1312	1418	1773	2127	2553*	2837*	3546*	3882	-
	1200	67.0	48.0	81.0	90.0	151	165	242	268	443	497	620	729	1059	1144	1431	1717	2060*	2290	2862	3133*	-
	1000	56.0	40.0	67.0	74.0	125	138	202	223	370	415	518	610	884	957	1195	1435	1722	1914	2392	2619	-
20.0	1800	90.0	64.0	111	126	208	240	343	377	610	699	871	1009	1470*	1604*	1922*	2306*	2884*	3191*	4037*	4373*	-
	1500	75.0	53.0	93.0	105	173	200	286	314	508	581	726	840	1225	1337	1601	1922	2403*	2659*	3364*	3644*	-
	1200	60.0	43.0	73.0	84.0	139	160	228	251	406	465	580	672	980	1070	1281	1537	1922	2127*	2691	2915*	-
	1000	50.0	36.0	61.0	70.0	115	133	190	209	339	388	483	560	817	891	1068	1281	1601	1773	2242	2430	-
22.4	1800	80.0	57.0	99.0	120	185	225	305	357	542	646	774	922	1307*	1478*	1709*	2050*	2563*	2948*	3588*	4016*	-
	1500	67.0	48.0	83.0	101	155	189	255	299	454	541	649	772	1094	1237	1431	1717	2146	2468*	3005*	3363*	-
	1200	54.0	38.0	66.0	82.0	124	152	205	241	366	436	522	622	882	998	1153	1384	1730	1989	2421*	2710	-
	1000	45.0	32.0	55.0	67.0	104	126	171	200	305	363	436	518	734	831	961	1153	1441	1658	2019	2258	-
25.0	1800	72.0	51.0	89.0	118	166	209	274	337	488	594	697	868	1176*	1330*	1537*	1845*	2306*	2653*	3229*	3614*	-
	1500	60.0	43.0	73.0	99.0	139	173	228	281	406	495	580	723	980	1108	1281	1537	1922	2210	2691*	3011*	-
	1200	48.0	34.0	59.0	79.0	111	139	183	224	325	396	464	578	784	886	1025	1230	1537	1769	2152*	2409	-
	1000	40.0	29.0	49.0	65.0	92.0	115	152	187	270	329	387	482	653	738	854	1025	1281	1474	1794	2007	-
28.0	1800	64.0	45.0	79.0	105	148	186	244	299	434	527	619	772	1046*	1182*	1367*	1640*	2050*	2358*	2870*	3212*	-
	1500	54.0	38.0	66.0	89.0	124	156	205	252	366	445	522	651	882	998	1153	1384	1730	1989	2421	2710*	-
	1200	43.0	31.0	53.0	70.0	99.0	124	163	201	291	354	416	518	702	794	918	1102	1377	1584	1929	2158*	-
	1000	36.0	26.0	44.0	59.0	83.0	104	137	168	244	297	348	434	588	665	768	922	1153	1326	1615	1806	-
31.5	1800	57.0	40.0	70.0	94.0	132	165	217	266	387	469	552	687	931*	1053*	1217*	1461*	1826*	2100*	2556*	2861*	-
	1500	48.0	34.0	59.0	79.0	111	139	183	224	325	396	464	578	784	886	1025	1230	1537	1769	2152	2409	-
	1200	38.0	27.0	47.0	62.0	88.0	110	145	177	257	313	367	458	620	702	811	973	1217	1399	1704	1907	-
	1000	32.0	22.0	39.0	52.0	73.0	93.0	121	149	216	263	309	386	522	591	683	820	1025	1179	1435	1605	-
35.5	1800	51.0	36.0	62.0	84.0	117	148	194	238	346	420	494	615	833*	941*	1089*	1307*	1634*	1879*	2287*	2559*	-
	1500	42.0	30.0	52.0	69.0	97.0	121	160	196	285	346	406	506	685	775	897	1076	1345	1547	1884	2108	-
	1200	34.0	24.0	42.0	56.0	79.0	98.0	130	158	231	279	328	410	555	627	726	871	1089	1253	1525	1706	-
	1000	28.0	19.0	35.0	46.0	64.0	81.0	106	131	190	231	270	338	457	517	598	717	897	1031	1256	1406	-
40.0	1800	45.0	32.0	55.0	75.0	104	131	171	210	305	370	436	543	734*	831*	961*	1153*	1441*	1658*	2019*	2258*	-
	1500	38.0	27.0	47.0	62.0	88.0	110	145	177	257	313	367	458	620	702	811	973	1217	1399	1704	1907	-
	1200	30.0	21.0	37.0	49.0	69.0	87.0	114	140	203	247	290	361	490	554	641	768	961	1105	1345	1506	-
	1000	25.0	17.0	31.0	41.0	57.0	72.0	95.0	116	169	206	242	301	408	461	533	641	801	921	1121	1255	-
45.0	1800	40.0	29.0	49.0	65.0	92.0	115	152	187	270	329	387	482	653*	738*	854*	1025*	1281*	1474*	1794*	2007*	-
	1500	33.0	24.0	41.0	54.0	76.0	95.0	125	154	223	271	319	398	539	609	705	846	1057	1216	1480	1656	-
	1200	27.0	18.0	33.0	44.0	62.0	78.0	102	125	183	222	261	325	441	499	576	692	865	995	1211	1355	-
	1000	22.0	15.0	27.0	36.0	50.0	63.0	84.0	102	149	181	212	265	359	406	469	563	705	810	986	1104	-
50.0	1800	36.0	26.0	44.0	59.0	83.0	104	137	168	224	297	348	434	588	665*	768*	922*	1153*	1326*	1615*	1806*	-
	1500	30.0	21.0	37.0	49.0	69.0	87.0	114	140	203	247	290	361	490	554	641	768	961	1105	1345	1506	-
	1200	24.0	16.0	30.0	39.0	55.0	69.0	91.0	112	162	198	232	289	392	443	512	615	768	884	1076	1205	-
	1000	20.0	14.0	25.0	33.0	46.0	57.0	76.0	93.0	135	164	193	241	326	369	426	512	641	736	897	1004	-
56.0	1800	32.0	22.0	39.0	52.0	73.0	93.0	121	149	216	263	309	386	522	591	683*	820*	1025*	1179*	1435*	1605*	-
	1500	27.0	18.0	33.0	44.0	62.0	78.0	102	125	183	222	261	325	441	499	576	692	865	995	1211	1355	-
	1200	21.0	14.0	26.0	35.0	48.0	60.0	80.0	98.0	142	172	203	253	343	388	448	538	672	773	941	1054	-
	1000	17.9	12.0	21.0	30.0	41.0	51.0	67.0	84.0	121	147	173	215	292	330	381						

TR NOMİNAL ÇIKIŞ MOMENTLERİ T_{2N} (kNm)

EN NOMINAL OUTPUT TORQUES T_{2N} (kNm)

DE NENN-ABTRIEBSDREHMOMENTE T_{2N} (kNm)

İN	Redüktör Gövdeleri / Gear unit sizes / Getriebegrößen																		
	43	53	63	73	83	93	103	113	123	133	143	153	163	173	183	193	203	213	223
12.5	5.6	9.6	-	17.3	-	28.6	-	53.4	-	81.1	-	135	-	199	-	255	-	347	-
14.0	6.1	10.0	-	18.6	-	30.1	-	57.8	-	83.2	-	140	151	199	235	267	301	367	413
16.0	6.7	10.7	12.2	20.2	21.9	31.6	36.3	61.1	67.6	85.5	101	145	157	204	235	281	314	388	430
18.0	6.8	11.5	12.9	21.5	23.6	34.6	38.3	63.2	70.9	88.4	104	151	163	204	245	294	326	408	447
20.0	6.8	11.8	13.5	22.1	25.5	36.4	40.1	64.8	74.2	92.5	107	156	170	204	245	306	339	428	464
22.4	6.8	11.8	14.5	22.1	27.0	36.4	42.6	64.8	77.1	92.5	110	156	176	204	245	306	352	428	479
25.0	6.8	11.8	15.8	22.1	27.7	36.4	44.7	64.8	78.7	92.5	115	156	176	204	245	306	352	428	479
28.0	6.8	11.8	15.8	22.1	27.7	36.4	44.7	64.8	78.7	92.5	115	156	176	204	245	306	352	428	479
31.5	6.8	11.8	15.8	22.1	27.7	36.4	44.7	64.8	78.7	92.5	115	156	176	204	245	306	352	428	479
35.5	6.8	11.8	15.8	22.1	27.7	36.4	44.7	64.8	78.7	92.5	115	156	176	204	245	306	352	428	479
40.0	6.8	11.8	15.8	22.1	27.7	36.4	44.7	64.8	78.7	92.5	115	156	176	204	245	306	352	428	479
45.0	6.8	11.8	15.8	22.1	27.7	36.4	44.7	64.8	78.7	92.5	115	156	176	204	245	306	352	428	479
50.0	6.8	11.8	15.8	22.1	27.7	36.4	44.7	64.8	78.7	92.5	115	156	176	204	245	306	352	428	479
56.0	6.8	11.8	15.8	22.1	27.7	36.4	44.7	64.8	78.7	92.5	115	156	176	204	245	306	352	428	479
63.0	6.7	11.6	15.8	21.8	27.7	36.4	44.7	64.8	78.7	92.5	115	156	176	204	245	306	352	428	479
71.0	6.7	11.2	15.8	20.4	27.7	34.7	44.7	61.2	78.7	92.5	115	156	176	204	245	306	352	428	479
80.0	-	-	14.3	-	27.4	-	44.7	-	78.7	-	115	-	176	-	245	-	352	-	479
90.0	-	-	14.3	-	25.7	-	43.9	-	76.5	-	115	-	-	-	-	-	-	-	-

TR TERMAL KAPASİTELER Pt (kW)

EN THERMAL CAPACITIES Pt (kW)

DE WÄRMEGRENZLEISTUNGEN Pt (kW)

iN	Pt (kW)	Redüktör Gövdeleri / Gear unit sizes / Getriebegrößen																n ₁ =1000 min ⁻¹			
		43	53	63	73	83	93	103	113	123	133	143	153	163	173	183	193	203	213	223	
12.5	Pt1	38.9	51.8	-	81.3	-	105	-	143	-	175	-	225	-	240	-	*	-	*	-	
	Pt2	67.6	95.8	-	153	-	208	-	327	-	427	-	595	-	757	-	*	-	*	-	
	Pt3	78.3	126	-	222	-	329	-	465	-	728	-	1139	-	1366	-	*	-	*	-	
	Pt4	102	164	-	286	-	421	-	625	-	941	-	1438	-	1780	-	*	-	*	-	
14.0	Pt1	37.8	50.4	-	78.9	-	103	-	142	-	181	-	224	238	240	264	*	*	*	*	
	Pt2	65.7	92.7	-	147	-	202	-	321	-	432	-	573	616	730	814	*	*	*	*	
	Pt3	76.0	121	-	214	-	319	-	456	-	733	-	1087	1152	1312	1438	*	*	*	*	
	Pt4	99.1	158	-	275	-	407	-	612	-	951	-	1376	1462	1711	1875	*	*	*	*	
16.0	Pt1	35.9	48.9	56.5	75.5	87.9	101	112	136	158	168	195	225	232	246	250	*	*	*	*	
	Pt2	62.5	89.3	102	140	161	197	218	306	354	396	457	564	591	727	747	*	*	*	*	
	Pt3	72.2	117	131	204	227	310	350	434	568	667	755	1064	1101	1290	1318	*	*	*	*	
	Pt4	94.0	152	168	262	291	396	443	580	738	863	978	1348	1393	1687	1716	*	*	*	*	
18.0	Pt1	35.0	47.4	54.8	73.1	84.9	98.4	104	135	159	170	199	220	235	242	268	*	*	*	*	
	Pt2	60.7	86.5	99.0	136	156	191	201	299	354	400	461	542	584	700	778	*	*	*	*	
	Pt3	69.9	113	124	196	221	299	321	424	569	671	760	1021	1084	1234	1359	*	*	*	*	
	Pt4	91.3	147	162	252	283	383	407	569	741	870	984	1290	1371	1616	1773	*	*	*	*	
20.0	Pt1	33.0	45.5	52.9	70.3	81.0	94.7	107	129	150	162	184	216	227	239	251	276	*	275	*	
	Pt2	57.2	82.9	95.4	130	148	183	207	286	329	374	421	523	559	675	714	830	*	917	*	
	Pt3	66.1	109	120	188	208	286	329	404	526	627	691	980	1030	1187	1238	*	*	*	*	
	Pt4	86.0	141	157	241	266	367	418	542	685	814	895	1239	1306	1553	1621	*	*	*	*	
22.4	Pt1	32.2	44.9	51.4	68.1	78.9	92.5	99.5	124	151	157	189	214	223	241	248	282	292	285	275	
	Pt2	55.7	81.6	92.5	126	144	179	190	271	330	356	425	508	539	659	689	811	850	899	925	
	Pt3	64.3	107	117	182	202	277	301	374	525	585	697	928	985	1136	1187	*	*	*	*	
	Pt4	83.8	140	152	231	258	355	383	505	684	761	903	1178	1252	1490	1556	*	*	*	*	
25.0	Pt1	30.7	42.6	49.6	66.3	76.2	89.0	96.2	119	147	152	180	208	226	239	255	287	303	298	297	
	Pt2	52.7	77.0	88.6	121	137	169	182	255	315	336	398	475	523	619	674	778	832	863	911	
	Pt3	60.6	101	112	172	193	258	290	344	499	538	651	839	937	1033	1138	*	*	*	*	
	Pt4	78.9	131	145	221	248	330	366	463	653	701	844	1068	1191	1360	1496	*	*	*	*	
28.0	Pt1	29.6	41.4	49.0	63.3	74.2	85.6	94.6	115	143	147	175	209	220	244	253	291	308	307	312	
	Pt2	50.4	74.2	87.2	114	133	160	177	243	301	318	380	462	490	608	633	746	798	827	874	
	Pt3	57.1	95.9	111	159	187	240	279	319	465	499	605	805	849	1000	1035	*	*	*	*	
	Pt4	74.6	123	144	205	239	308	356	432	608	653	787	1027	1081	1318	1363	*	*	*	*	
31.5	Pt1	28.1	39.4	46.4	60.4	71.7	82.2	90.9	110	136	142	168	200	219	237	255	285	308	305	318	
	Pt2	47.7	70.1	82.2	108	128	152	168	230	282	302	357	431	477	568	620	702	764	774	837	
	Pt3	53.6	89.4	104	149	177	224	259	297	425	462	554	729	813	914	1002	*	*	*	*	
	Pt4	70.0	115	136	192	226	288	330	403	559	607	724	935	1040	1208	1322	*	*	*	*	
35.5	Pt1	26.4	37.1	44.9	57.5	68.3	78.4	87.0	107	131	138	162	196	209	233	246	284	299	303	312	
	Pt2	44.7	65.6	79.1	102	121	144	159	219	267	290	339	415	444	549	580	679	717	746	782	
	Pt3	49.3	81.8	98.7	138	165	205	242	282	397	440	516	694	740	870	915	*	*	*	*	
	Pt4	64.4	106	129	178	211	265	308	380	519	577	675	890	948	1152	1212	*	*	*	*	
40.0	Pt1	23.1	32.3	42.6	50.4	65.4	73.5	83.2	102	124	131	155	187	203	224	241	272	295	293	308	
	Pt2	38.9	56.6	74.8	88.8	114	134	152	205	251	272	321	391	427	518	559	640	693	700	753	
	Pt3	41.5	68.0	92.2	114	154	186	226	258	367	405	480	640	701	809	870	*	*	*	*	
	Pt4	54.3	88.7	119	147	197	240	289	351	482	533	629	824	902	1074	1155	*	*	*	*	
45.0	Pt1	22.5	31.5	40.1	49.0	62.1	67.7	79.3	93.4	119	121	150	174	194	210	233	258	284	275	297	
	Pt2	37.9	55.1	69.9	85.8	108	122	143	188	241	249	307	359	403	479	530	594	651	647	706	
	Pt3	40.3	65.6	84.6	110	142	167	207	232	347	363	455	575	647	733	814	*	*	*	*	
	Pt4	52.8	85.7	109	142	183	215	265	317	458	476	598	743	834	974	1078	*	*	*	*	
50.0	Pt1	22.8	31.4	35.1	48.6	54.7	66.8	74.6	94.2	114	124	144	182	183	223	220	261	272	308	289	
	Pt2	38.1	54.4	60.6	84.2	94.4	119	134	185	225	249	289	363	370	488	491	572	607	681	654	
	Pt3	40.3	63.9	70.6	106	118	159	188	226	318	359	420	578	582	742	740	*	*	*	*	
	Pt4	52.6	83.5	92.1	137	152	207	241	307	419	475	554	743	753	981	982	*	*	*	*	
56.0	Pt1	21.1	29.1	34.3	45.2	53.1	61.9	69.1	86.2	105	115	134	168	190	209	233	256	273	303	318	
	Pt2	35.1	50.3	59.0	78.2	91.4	110	122	167	207	227	263	332	372	447	498	551	582	643	689	
	Pt3	36.3	57.5	68.0	96.6	113	143	169	201	285	321	373	517	584	667	744	*	*	*	*	
	Pt4	47.7	75.6	88.9	124	146	186	217	273	377	424	496	665	753	884	985	*	*	*	*	
63.0	Pt1	20.3	27.9	34.1	43.7	52.5	59.9	67.8	83.3	105	111	136	162	174	202	215	250	265	293	304	
	Pt2	33.8	48.2	58.2	75.6	89.9	106	119	161	202	218	264	315	340	427	456	530	560	620	646	
	Pt3	34.4	54.4	66.3	91.6	110	135	162	189	276	302	372	485	520	627	670	*	*	*	*	
	Pt4	45.2	71.5	86.8	118	143	176	207	258	365	401	491	624	672	836	886	*	*	*	*	
71.0	Pt1	18.8	26.6	31.4	41.6	48.8	56.1	62.9	77.2	96.7	105	124	154	167	191	208	237	257	277	297	
	Pt2	31.3	45.8	53.7	71.9	83.3	99.8	110	149	184	205	241	298	324	401	435	497	540	580	624	
	Pt3	31.2	50.3	60.0	84.8	100	121	146	169	245	273	334	446	491	580	632	*	*	*	*	
	Pt4	41.2	66.5	78.6	110	130	160	187	233	325	363	440	578	633	772	840	*	*	*	*	
80.0	Pt1	-	-	30.1	-	47.1	-	60.8	-	92.5	-	119	-	160	-	197	-	244	-	282	
	Pt2	-	-	51.6	-	80.6	-	107	-	176	-	232	-	307	-	408	-	505	-	585	
	Pt3	-	-	56.5	-	95.1	-	137	-	228	-	313	-	451	-	581	-	*	-	*	
	Pt4	-	-	74.3	-	123	-	177	-	306	-	415	-	584	-	776	-	*	-	*	
90.0	Pt1	-	-	28.8	-	44.9	-	57.0	-	86.2	-	112	-	-	-	-	-	-	-	-	
	Pt2	-	-	49.1	-	76.6	-	100	-	164	-	216	-	-	-	-	-	-	-	-	
	Pt3	-	-	52.4	-	88.0	-	123	-	205	-	283	-	-	-	-	-	-	-	-	
	Pt4	-	-	69.3	-	114	-	162	-	276	-	376	-	-	-	-	-	-	-	-	

Ek notlar için, PB...2 tipine bakınız.

* Talep edildiğinde

For additional notes, see type PB...2.

* On request

Weitere Hinweise siehe Bauart PB...2

* Auf Anfrage

TR TERMAL KAPASİTELER Pt (kW)

EN THERMAL CAPACITIES Pt (kW)

DE WÄRMEGRENZLEISTUNGEN Pt (kW)

iN	Pt (kW)	Redüktör gövdeleri / Gear unit sizes / Getriebegrößen																	n ₁ =1200 min ⁻¹			
		43	53	63	73	83	93	103	113	123	133	143	153	163	173	183	193	203	213	223		
12.5	Pt1	40.5	53.1	-	82.3	-	105	-	135	-	155	-	176	-	*	-	*	-	*	-		
	Pt2	77.1	108	-	172	-	235	-	363	-	466	-	632	-	793	-	*	-	*	-		
	Pt3	87.2	141	-	248	-	366	-	518	-	811	-	1268	-	1521	-	*	-	*	-		
	Pt4	117	188	-	327	-	481	-	711	-	1063	-	1609	-	1978	-	*	-	*	-		
14.0	Pt1	39.6	52.0	-	80.6	-	103	-	137	-	164	-	185	190	*	*	*	*	*	*		
	Pt2	75.0	105	-	166	-	227	-	357	-	474	-	615	658	773	855	*	*	*	*		
	Pt3	84.6	136	-	239	-	356	-	507	-	817	-	1211	1282	1461	1601	*	*	*	*		
	Pt4	113	182	-	315	-	466	-	697	-	1075	-	1543	1637	1908	2087	*	*	*	*		
16.0	Pt1	37.7	50.5	58.1	77.2	89.3	102	112	132	150	154	177	189	190	193	*	*	*	*	*		
	Pt2	71.4	101	115	159	182	222	245	341	392	435	502	609	633	773	789	*	*	*	*		
	Pt3	80.4	131	145	227	253	345	390	482	632	743	840	1184	1225	1436	1467	*	*	*	*		
	Pt4	107	174	194	300	333	453	506	661	839	977	1107	1516	1563	1886	1914	*	*	*	*		
18.0	Pt1	36.7	49.1	56.6	75.1	86.5	99.7	104	132	152	158	184	189	197	195	209	*	*	*	*		
	Pt2	69.3	98.4	112	154	176	215	226	335	394	441	508	587	629	749	827	*	*	*	*		
	Pt3	77.8	125	139	218	246	333	358	472	633	747	846	1137	1207	1374	1513	*	*	*	*		
	Pt4	104	169	187	290	323	438	466	648	842	986	1115	1452	1540	1811	1981	*	*	*	*		
20.0	Pt1	34.7	47.3	54.8	72.3	82.8	96.2	108	126	144	152	171	189	195	198	202	215	*	*	*		
	Pt2	65.4	94.5	108	148	168	206	233	320	367	414	465	568	605	725	764	882	*	*	938		
	Pt3	73.6	121	135	209	232	318	366	450	585	699	769	1091	1146	1322	1379	*	*	*	*		
	Pt4	98.8	162	180	275	306	420	478	617	779	923	1015	1397	1469	1744	1816	*	*	*	*		
22.4	Pt1	34.0	46.7	53.3	70.3	81.0	94.4	101	122	147	150	177	191	196	205	206	226	231	*	*		
	Pt2	63.6	92.9	105	143	163	202	214	304	368	395	471	555	585	712	740	867	906	928	938		
	Pt3	71.6	119	131	202	224	309	336	417	584	652	776	1033	1098	1265	1322	*	*	*	*		
	Pt4	96.4	161	174	265	296	407	438	576	779	864	1025	1330	1411	1677	1746	*	*	*	*		
25.0	Pt1	32.4	44.6	51.6	68.7	78.6	91.5	98.3	119	145	147	173	193	206	212	223	246	255	*	*		
	Pt2	60.3	87.9	101	138	156	192	206	287	353	374	444	523	574	675	732	843	898	907	945		
	Pt3	67.4	112	124	192	215	288	322	383	556	599	724	934	1043	1151	1267	*	*	*	*		
	Pt4	90.8	150	166	254	285	378	419	529	745	799	960	1210	1348	1535	1687	*	*	*	*		
28.0	Pt1	31.3	43.5	51.3	66.1	77.0	88.5	97.5	116	143	146	173	199	208	226	232	262	274	249	*		
	Pt2	57.7	84.7	99.5	130	151	183	201	274	339	357	425	513	542	669	696	816	871	885	924		
	Pt3	63.6	106	123	177	208	266	311	356	518	556	673	897	945	1113	1153	*	*	*	*		
	Pt4	85.9	142	165	236	273	353	408	496	696	746	899	1168	1228	1494	1543	*	*	*	*		
31.5	Pt1	29.7	41.4	48.8	63.2	74.9	85.6	94.2	113	138	143	168	195	212	225	241	265	285	262	261		
	Pt2	54.8	80.1	93.9	123	146	173	192	259	318	340	401	482	531	631	686	775	840	838	899		
	Pt3	59.7	99.5	116	165	198	250	289	330	473	515	617	812	905	1018	1115	*	*	*	*		
	Pt4	80.5	133	156	220	260	330	379	462	640	694	827	1065	1184	1372	1500	*	*	*	*		
35.5	Pt1	28.1	39.2	47.2	60.4	71.6	81.9	90.6	110	134	140	163	193	205	225	237	270	283	270	268		
	Pt2	51.2	75.1	90.4	116	139	164	182	249	302	327	383	466	497	611	646	754	795	814	847		
	Pt3	54.9	91.1	109	154	184	228	269	313	442	490	575	772	823	968	1019	*	*	*	*		
	Pt4	74.2	122	147	204	243	304	354	437	596	661	773	1016	1080	1312	1378	*	*	*	*		
40.0	Pt1	24.5	34.2	45.0	53.0	68.6	76.9	86.9	104	128	133	158	186	201	219	235	263	283	267	271		
	Pt2	44.6	64.8	85.5	102	131	153	173	234	285	308	362	439	479	579	623	712	769	768	820		
	Pt3	46.2	75.8	102	128	171	206	252	288	409	451	536	712	780	901	968	*	*	*	*		
	Pt4	62.5	102	138	169	226	275	332	403	553	611	720	941	1029	1224	1315	*	*	*	*		
45.0	Pt1	24.0	33.4	42.3	51.6	65.3	71.0	82.9	96.9	123	124	153	174	193	208	228	252	275	256	268		
	Pt2	43.5	63.0	80.0	98.0	123	140	163	214	273	282	348	405	453	537	593	663	726	712	773		
	Pt3	44.9	73.0	94.1	122	158	186	231	258	386	404	506	641	720	817	906	*	*	*	*		
	Pt4	60.9	98.6	126	162	209	248	305	364	525	546	684	849	953	1112	1229	*	*	*	*		
50.0	Pt1	24.3	33.4	37.1	51.3	57.7	70.5	78.5	98.5	118	129	149	186	186	225	222	262	271	299	274		
	Pt2	43.8	62.3	69.4	96.4	107	136	153	211	256	284	327	410	419	550	553	644	682	759	726		
	Pt3	44.9	71.1	78.5	118	132	177	209	252	355	400	468	644	649	825	823	*	*	*	*		
	Pt4	60.6	96.2	105	157	175	239	277	353	481	546	635	851	862	1123	1123	*	*	*	*		
56.0	Pt1	22.4	30.8	36.4	47.9	56.3	65.6	72.9	90.7	110	120	139	174	195	214	238	261	277	299	313		
	Pt2	40.2	57.6	67.6	89.7	104	126	140	192	237	259	300	376	423	507	564	623	658	722	770		
	Pt3	40.4	64.1	75.8	107	125	159	189	223	317	358	416	576	651	743	827	*	*	*	*		
	Pt4	55.0	87.1	102	144	168	214	250	314	435	488	569	763	863	1014	1129	*	*	*	*		
63.0	Pt1	21.6	29.7	36.2	46.4	55.7	63.4	71.8	87.8	110	116	142	168	181	208	221	256	271	295	303		
	Pt2	38.8	55.4	66.8	86.6	102	121	137	184	232	249	302	359	386	485	517	601	634	700	726		
	Pt3	38.3	60.5	73.8	102	122	150	181	210	308	337	415	540	579	699	746	*	*	*	*		
	Pt4	52.0	82.4	100	137	164	203	239	297	419	461	564	717	772	960	1017	*	*	*	*		
71.0	Pt1	20.0	28.3	33.5	44.2	51.8	59.5	66.6	81.5	102	110	131	161	173	198	214	244	264	281	298		
	Pt2	36.0	52.6	61.5	82.5	95.5	114	126	170	210	234	274	340	369	455	494	564	612	656	703		
	Pt3	34.8	56.0	66.7	94.4	111	136	162	189	272	304	371	497	546	646	704	*	*	*	*		
	Pt4	47.5	76.6	90.6	128	149	185	215	267	374	418	505	664	727	886	964	*	*	*	*		
80.0	Pt1	-	-	32.0	-	50.1	-	64.4	-	97.4	-	125	-	166	-	204	-	252	-	284		
	Pt2	-	-	59.3	-	92.3	-	122	-	202	-	264	-	350	-	463	-	574	-	660		
	Pt3	-	-	62.9	-	105	-	152	-	255	-	349	-	502	-	647	-	*	-	*		
	Pt4	-	-	85.6	-	142	-	204	-	352	-	477	-	671	-	890	-	*	-	*		
90.0	Pt1	-	-	30.6	-	47.7	-	60.5	-	91.0	-	117	-	-	-	-	-	-	-	-		
	Pt2	-	-	56.3	-	87.8	-	114	-	188	-	247	-	-	-	-	-	-	-	-		
	Pt3	-	-	58.3	-	98.0	-	138	-	228	-	315	-	-	-	-	-	-	-	-		
	Pt4	-	-	79.8	-	132	-	187	-	317	-	434	-	-	-	-	-	-	-	-		

Ek notlar için, PB...2 tipine bakınız.

☐ * Talep edildiğinde

For additional notes, see type PB...2.

☐ * On request

Weitere Hinweise siehe Bauart PB...2

☐ * Auf Anfrage

TR TERMAL KAPASİTELER Pt (kW)

EN THERMAL CAPACITIES Pt (kW)

DE WÄRMEGRENZLEISTUNGEN Pt (kW)

iN	Pt (kW)	Redüktör gövdeleri / Gear unit sizes / Getriebegrößen																	n ₁ =1500 min ⁻¹			
		43	53	63	73	83	93	103	113	123	133	143	153	163	173	183	193	203	213	223		
12.5	Pt1	40.2	51.4	-	78.2	-	97.3	-	114	-	*	-	*	-	*	-	*	-	*	-	*	-
	Pt2	86.5	120	-	190	-	255	-	385	-	477	-	614	-	743	-	*	-	*	-	*	-
	Pt3	96.6	154	-	270	-	398	-	553	-	848	-	1286	-	1514	-	*	-	*	-	*	-
	Pt4	134	213	-	369	-	540	-	783	-	1149	-	1685	-	2031	-	*	-	*	-	*	-
14.0	Pt1	39.4	50.6	-	77.2	-	97.1	-	119	-	130	-	*	-	*	-	*	-	*	-	*	-
	Pt2	84.3	116	-	184	-	249	-	381	-	492	-	610	-	644	-	743	-	808	-	*	-
	Pt3	93.7	149	-	262	-	388	-	544	-	860	-	1241	-	1306	-	1472	-	1600	-	*	-
	Pt4	130	206	-	357	-	524	-	771	-	1170	-	1635	-	1722	-	1986	-	2152	-	*	-
16.0	Pt1	37.5	49.3	56.5	74.4	85.0	96.2	105	116	128	124	141	*	*	*	*	*	*	*	*	*	*
	Pt2	80.2	112	129	175	200	244	267	365	415	454	521	609	627	752	756	*	*	*	*	*	*
	Pt3	89.1	144	160	249	277	376	423	518	675	784	885	1220	1255	1458	1476	*	*	*	*	*	*
	Pt4	123	199	220	341	376	510	569	733	925	1068	1205	1615	1653	1976	1988	*	*	*	*	*	*
18.0	Pt1	36.6	48.1	55.2	72.5	82.7	94.4	98.2	117	132	131	149	*	*	*	*	*	*	*	*	*	*
	Pt2	77.9	109	124	170	195	237	248	360	419	463	530	593	629	736	803	*	*	*	*	*	*
	Pt3	86.4	139	153	240	270	364	391	509	678	793	895	1178	1243	1403	1533	*	*	*	*	*	*
	Pt4	119	193	212	328	366	495	524	721	931	1081	1219	1556	1640	1909	2074	*	*	*	*	*	*
20.0	Pt1	34.7	46.5	53.7	70.2	79.6	91.6	102	114	126	129	143	*	*	*	*	*	*	*	*	*	*
	Pt2	73.5	105	120	164	186	227	256	346	393	437	490	579	611	722	751	856	*	*	*	*	*
	Pt3	81.7	134	148	230	254	349	400	486	628	744	816	1136	1188	1359	1407	*	*	*	*	*	*
	Pt4	113	185	205	313	347	475	540	690	865	1016	1114	1505	1573	1851	1914	*	*	*	*	*	*
22.4	Pt1	34.0	46.0	52.4	68.5	78.2	90.4	95.8	112	131	129	151	*	*	*	*	*	*	*	*	*	*
	Pt2	71.7	103	117	158	181	222	236	330	396	420	499	570	598	716	736	853	881	840	809	*	*
	Pt3	79.5	133	145	222	247	339	367	452	629	697	827	1082	1143	1308	1359	*	*	*	*	*	*
	Pt4	110	184	199	302	337	461	495	645	867	955	1129	1440	1520	1791	1854	*	*	*	*	*	*
25.0	Pt1	32.5	44.2	51.1	67.5	76.7	88.6	94.7	111	133	131	153	156	163	*	*	*	*	*	*	*	*
	Pt2	68.0	98.5	112	154	173	213	227	313	383	403	475	548	597	695	747	850	899	858	861	*	*
	Pt3	75.1	124	138	212	237	316	354	416	602	645	777	989	1100	1205	1320	*	*	*	*	*	*
	Pt4	104	171	190	290	323	430	475	596	833	887	1066	1323	1469	1662	1816	*	*	*	*	*	*
28.0	Pt1	31.5	43.4	51.0	65.4	75.9	86.7	95.0	111	134	134	158	171	175	187	186	204	*	*	*	*	*
	Pt2	65.2	95.2	111	146	168	203	224	302	370	388	461	546	573	703	725	845	896	872	886	*	*
	Pt3	70.8	118	137	197	230	294	343	390	565	602	729	958	1007	1180	1217	*	*	*	*	*	*
	Pt4	98.6	162	189	269	312	403	464	560	782	835	1005	1290	1353	1637	1683	*	*	*	*	*	*
31.5	Pt1	30.0	41.5	48.8	62.9	74.2	84.4	92.5	108	132	134	157	173	187	194	203	220	232	*	*	*	*
	Pt2	61.9	90.3	105	139	163	194	214	288	351	372	439	518	569	671	726	815	880	848	888	*	*
	Pt3	66.5	110	129	184	219	276	318	363	518	561	671	874	971	1088	1188	*	*	*	*	*	*
	Pt4	92.6	152	179	252	298	377	432	524	723	781	930	1185	1314	1517	1652	*	*	*	*	*	*
35.5	Pt1	28.4	39.4	47.3	60.3	71.2	81.2	89.5	107	128	133	154	176	185	200	207	233	240	*	*	*	*
	Pt2	57.9	84.7	102	132	155	185	203	276	335	360	420	505	537	657	691	802	842	837	856	*	*
	Pt3	61.1	101	121	170	204	253	298	345	485	534	627	835	888	1041	1092	*	*	*	*	*	*
	Pt4	85.4	141	169	234	277	348	404	497	674	747	872	1136	1205	1458	1528	*	*	*	*	*	*
40.0	Pt1	24.8	34.4	45.2	53.0	68.4	76.5	86.1	102	123	128	150	171	184	198	208	231	245	212	*	*	*
	Pt2	50.4	73.0	96.5	114	147	171	195	260	316	341	400	478	520	626	670	762	821	799	838	*	*
	Pt3	51.5	84.4	113	141	191	228	279	316	449	494	585	773	846	973	1042	*	*	*	*	*	*
	Pt4	72.0	117	158	195	259	315	379	458	628	692	814	1056	1152	1366	1463	*	*	*	*	*	*
45.0	Pt1	24.3	33.6	42.6	51.8	65.3	70.8	82.4	95.1	120	119	147	163	180	191	207	225	245	211	210	*	*
	Pt2	49.3	71.2	90.3	110	140	157	184	239	304	312	385	443	494	583	642	714	780	748	801	*	*
	Pt3	50.0	81.3	104	136	175	206	256	286	425	444	555	698	783	885	979	*	*	*	*	*	*
	Pt4	70.1	113	145	187	241	285	349	415	597	619	775	955	1070	1245	1373	*	*	*	*	*	*
50.0	Pt1	24.7	33.7	37.5	51.7	58.0	70.7	78.5	97.7	117	126	145	177	177	214	208	245	252	265	237	*	*
	Pt2	49.7	70.6	78.4	108	121	154	172	237	287	316	365	454	462	605	606	704	745	815	772	*	*
	Pt3	50.1	79.3	87.5	132	147	198	233	279	392	442	516	706	710	902	898	*	*	*	*	*	*
	Pt4	69.9	110	121	181	201	274	318	404	550	622	723	963	975	1267	1265	*	*	*	*	*	*
56.0	Pt1	22.8	31.3	36.9	48.5	56.8	66.1	73.4	90.7	110	119	138	170	190	207	230	250	265	276	285	*	*
	Pt2	45.7	65.3	76.6	101	118	143	158	215	265	291	337	419	470	563	624	689	726	787	834	*	*
	Pt3	45.1	71.5	84.6	119	141	177	210	248	352	397	460	634	716	816	909	*	*	*	*	*	*
	Pt4	63.3	100	117	165	194	246	287	361	498	558	650	869	981	1151	1280	*	*	*	*	*	*
63.0	Pt1	22.0	30.1	36.7	47.0	56.3	64.1	72.4	88.0	110	116	141	165	176	203	215	248	261	277	281	*	*
	Pt2	44.1	62.8	75.7	98.1	116	138	154	207	260	281	339	401	430	540	574	667	703	767	792	*	*
	Pt3	42.7	67.5	82.4	113	137	167	201	234	342	373	460	597	640	770	821	*	*	*	*	*	*
	Pt4	60.1	94.9	114	157	189	234	274	341	480	527	646	818	879	1092	1156	*	*	*	*	*	*
71.0	Pt1	20.4	28.8	34.0	44.8	52.4	60.2	67.2	81.8	102	109	130	158	170	194	209	237	256	266	278	*	*
	Pt2	40.8	59.7	69.8	93.5	108	129	143	193	237	263	308	379	412	508	550	627	679	721	769	*	*
	Pt3	38.8	62.5	74.5	105	124	151	181	210	303	338	412	549	603	712	775	*	*	*	*	*	*
	Pt4	54.8	88.2	104	146	171	213	248	307	429	478	578	758	829	1010	1097	*	*	*	*	*	*
80.0	Pt1	-	-	32.5	-	50.7	-	65.1	-	97.7	-	125	-	164	-	200	-	245	-	267	*	*
	Pt2	-	-	67.2	-	104	-	139	-	228	-	297	-	392	-	517	-	639	-	724	*	*
	Pt3	-	-	70.2	-	117	-	170	-	284	-	387	-	555	-	714	-	*	-	*	*	*
	Pt4	-	-	98.6	-	163	-	236	-	404	-	547	-	766	-	1014	-	*	-	*	*	*
90.0	Pt1	-	-	31.1	-	48.3	-	61.2	-	91.4	-	117	-	-	-	-	-	-	-	-	-	-
	Pt2	-	-	64.0	-	99.6	-	130	-	212	-	278	-	-	-	-	-	-	-	-	-	-
	Pt3	-	-	65.1	-	109	-	154	-	254	-	350	-	-	-	-	-	-	-	-	-	-
	Pt4	-	-	91.9																		

TR TERMAL KAPASİTELER Pt (kW)

EN THERMAL CAPACITIES Pt (kW)

DE WÄRMEGRENZLEISTUNGEN Pt (kW)

iN	Pt (kW)	Redüktör gövdeleri / Gear unit sizes / Getriebegrößen																	n ₁ =1800 min ⁻¹			
		43	53	63	73	83	93	103	113	123	133	143	153	163	173	183	193	203	213	223		
12.5	Pt1	39.8	49.0	-	71.8	-	84.6	-	*	-	*	-	*	-	*	-	*	-	*	-	*	
	Pt2	95.4	131	-	205	-	272	-	396	-	470	-	559	-	634	-	*	-	*	-	*	
	Pt3	105	168	-	294	-	428	-	585	-	880	-	1296	-	1494	-	*	-	*	-	*	
	Pt4	151	239	-	411	-	597	-	852	-	1223	-	1738	-	2049	-	*	-	*	-	*	
14.0	Pt1	39.2	48.7	-	72.0	-	86.6	-	*	-	*	-	*	-	*	-	*	-	*	-	*	
	Pt2	93.0	128	-	200	-	267	-	398	-	493	-	572	593	663	701	*	*	*	*	*	
	Pt3	102	163	-	285	-	418	-	579	-	900	-	1265	1322	1474	1587	*	*	*	*	*	
	Pt4	146	231	-	398	-	581	-	843	-	1256	-	1707	1785	2036	2184	*	*	*	*	*	
16.0	Pt1	37.5	47.6	54.2	69.9	78.3	86.8	92.6	91.6	*	*	*	*	*	*	*	*	*	*	*	*	
	Pt2	88.6	123	141	191	216	263	287	383	427	459	523	579	587	684	671	*	*	*	*	*	
	Pt3	97.8	157	174	271	301	407	457	553	715	823	927	1251	1277	1469	1475	*	*	*	*	*	
	Pt4	139	222	246	379	418	566	630	803	1006	1151	1293	1695	1725	2040	2034	*	*	*	*	*	
18.0	Pt1	36.6	46.8	53.2	68.7	77.0	86.1	87.8	95.0	*	*	*	*	*	*	*	*	*	*	*	*	
	Pt2	86.2	120	137	186	211	255	266	378	435	471	538	571	598	682	728	*	*	*	*	*	
	Pt3	94.9	152	167	261	293	394	422	545	720	835	939	1214	1273	1423	1543	*	*	*	*	*	
	Pt4	135	216	238	367	408	550	581	792	1015	1169	1315	1642	1721	1985	2138	*	*	*	*	*	
20.0	Pt1	34.8	45.4	52.0	67.0	74.8	84.6	92.6	95.2	97.9	*	*	*	*	*	*	*	*	*	*	*	
	Pt2	81.5	115	132	179	202	246	275	365	409	449	499	566	589	681	695	776	*	*	634	*	
	Pt3	89.8	146	162	251	276	378	434	521	670	786	861	1177	1223	1387	1427	*	*	*	*	*	
	Pt4	128	207	230	351	387	529	600	758	945	1103	1206	1597	1661	1938	1988	*	*	*	*	*	
22.4	Pt1	34.3	45.2	51.1	65.9	74.2	84.4	87.9	95.6	104	*	*	*	*	*	*	*	*	*	*	*	
	Pt2	79.5	114	129	173	197	242	255	350	415	435	513	565	584	686	695	789	805	805	674	588	
	Pt3	87.4	145	158	243	268	368	398	486	672	740	875	1126	1184	1344	1387	*	*	*	*	*	
	Pt4	124	206	223	338	375	514	550	711	951	1039	1227	1537	1614	1888	1940	*	*	*	*	*	
25.0	Pt1	32.9	43.9	50.4	65.9	74.0	84.5	88.9	99.1	112	104	118	*	*	*	*	*	*	*	*	*	
	Pt2	75.6	108	124	168	190	233	248	336	406	422	496	555	599	687	728	819	857	747	702	*	
	Pt3	82.5	137	151	232	259	344	385	449	647	689	829	1040	1151	1254	1366	*	*	*	*	*	
	Pt4	117	193	213	325	362	480	530	660	919	973	1166	1427	1577	1773	1928	*	*	*	*	*	
28.0	Pt1	32.0	43.5	50.9	64.7	74.4	84.2	91.2	102	119	114	133	*	*	*	*	*	*	*	*	*	
	Pt2	72.5	105	123	160	186	222	245	326	398	412	489	565	589	714	730	843	886	810	788	*	
	Pt3	78.0	130	150	215	251	321	374	422	610	648	782	1018	1065	1242	1276	*	*	*	*	*	
	Pt4	111	183	213	302	351	451	519	623	868	921	1107	1406	1469	1769	1812	*	*	*	*	*	
31.5	Pt1	30.7	41.8	49.0	62.8	73.4	82.9	90.2	102	120	118	138	140	145	*	*	*	*	*	*	*	
	Pt2	69.0	100	116	153	181	213	235	312	378	399	469	545	594	695	746	830	891	818	831	*	
	Pt3	73.2	121	142	202	241	303	348	395	562	606	724	934	1035	1156	1258	*	*	*	*	*	
	Pt4	104	172	201	284	335	423	486	584	804	866	1029	1299	1437	1651	1794	*	*	*	*	*	
35.5	Pt1	29.1	39.9	47.8	60.6	71.1	80.5	88.0	102	120	121	140	149	152	158	158	*	*	*	*	*	
	Pt2	64.6	93.9	112	145	171	203	223	302	363	389	452	536	566	687	719	829	866	829	826	*	
	Pt3	67.4	111	134	188	223	277	326	376	526	579	679	898	952	1113	1164	*	*	*	*	*	
	Pt4	96.5	158	191	263	312	392	454	555	753	830	968	1253	1325	1597	1669	*	*	*	*	*	
40.0	Pt1	25.5	34.9	45.8	53.4	68.5	76.2	85.3	98.9	117	118	139	149	156	163	167	179	*	*	*	*	
	Pt2	56.2	81.2	107	126	163	190	215	285	344	369	432	510	552	660	704	795	853	802	824	*	
	Pt3	56.8	92.8	125	155	209	251	306	346	490	537	635	832	909	1042	1114	*	*	*	*	*	
	Pt4	81.4	132	179	219	292	355	426	513	702	770	906	1167	1270	1501	1603	*	*	*	*	*	
45.0	Pt1	25.0	34.2	43.4	52.3	65.7	70.9	82.0	92.6	115	112	137	145	157	162	172	183	194	*	*	*	
	Pt2	55.0	79.3	100	122	154	173	203	262	333	340	417	474	527	619	678	752	817	761	801	*	
	Pt3	55.2	89.6	115	150	194	226	281	312	463	482	604	754	845	952	1050	*	*	*	*	*	
	Pt4	79.3	128	164	210	270	320	392	466	668	691	864	1058	1183	1373	1511	*	*	*	*	*	
50.0	Pt1	25.4	34.6	38.5	52.7	59.0	71.6	79.3	97.1	115	122	141	166	164	195	188	216	220	210	*	*	
	Pt2	55.5	78.6	87.4	120	135	170	192	261	316	347	400	493	501	653	652	754	796	854	799	*	
	Pt3	55.3	87.4	96.5	145	161	217	255	306	429	482	563	767	770	977	970	*	*	*	*	*	
	Pt4	79.1	124	138	204	227	309	359	454	618	698	810	1074	1085	1408	1404	*	*	*	*	*	
56.0	Pt1	23.6	32.2	37.9	49.7	58.1	67.4	74.7	91.2	110	118	136	164	183	197	215	234	245	241	239	*	
	Pt2	51.0	72.8	85.4	112	132	159	176	239	294	320	370	459	514	613	678	746	786	839	883	*	
	Pt3	49.9	78.9	93.2	132	155	196	232	272	387	435	504	694	781	888	988	*	*	*	*	*	
	Pt4	71.7	113	133	187	219	277	324	406	560	626	730	973	1098	1285	1429	*	*	*	*	*	
63.0	Pt1	22.7	31.0	37.8	48.2	57.7	65.5	74.0	89.0	110	116	140	161	171	196	206	236	247	249	245	*	
	Pt2	49.3	70.1	84.6	109	130	153	171	231	289	309	374	440	472	591	627	726	765	824	845	*	
	Pt3	47.2	74.6	91.0	125	150	185	221	257	375	409	504	652	699	840	895	*	*	*	*	*	
	Pt4	68.0	107	130	177	214	264	310	385	542	594	726	917	985	1222	1292	*	*	*	*	*	
71.0	Pt1	21.1	29.7	35.0	46.1	53.8	61.6	68.7	82.9	102	109	130	156	166	188	202	226	244	243	248	*	
	Pt2	45.7	66.6	77.8	104	120	144	159	214	262	291	341	417	453	557	602	684	741	778	824	*	
	Pt3	42.8	69.1	82.2	115	137	166	199	231	334	370	452	601	660	778	847	*	*	*	*	*	
	Pt4	62.0	99.9	117	165	194	241	281	347	483	539	651	851	930	1131	1228	*	*	*	*	*	
80.0	Pt1	-	-	33.6	-	52.1	-	66.6	-	98.8	-	125	-	161	-	194	-	236	-	242	*	

TR NÖMİNAL GÜÇ DEĞERLERİ P_{2N} (kW)EN NOMINAL POWER RATINGS P_{2N} (kW)DE NENNLEISTUNGEN P_{2N} (kW)

iN	n1 min-1	n2 min-1	Redüktör Gövdeleri / Gear unit sizes / Getriebegrößen																	
			54	64	74	84	94	104	114	124	134	144	154	164	174	184	194	204	214	224
80	1800	23.0	28.0	-	53.0	-	87.0	-	151	-	222	-	375	-	491	-	736*	-	1031*	-
	1500	18.8	22.0	-	43.0	-	71.0	-	123	-	182	-	307	-	401	-	602	-	843	-
	1200	15.0	18.0	-	35.0	-	57.0	-	98.0	-	145	-	245	-	320	-	480	-	672	-
	1000	12.5	15.0	-	29.0	-	47.0	-	82.0	-	120	-	204	-	266	-	400	-	560	-
90	1800	20.0	25.0	-	46.0	-	76.0	-	132	-	193	-	326	369	426	512	641*	736*	897*	1004*
	1500	16.7	20.0	-	38.0	-	63.0	-	109	-	161	-	272	308	356	427	534	615	749	837
	1200	13.3	16.0	-	31.0	-	50.0	-	87.0	-	129	-	217	245	284	341	425	490	596	667
	1000	11.1	13.0	-	26.0	-	42.0	-	72.0	-	107	-	181	205	237	284	355	408	498	557
100	1800	18.0	21.0	30.0	41.0	52.0	68.0	85.0	118	150	173	216	294	333	384	461	576*	663*	807*	903*
	1500	15.0	18.0	25.0	35.0	43.0	57.0	70.0	98.0	124	145	181	245	276	320	384	480	552	672	753
	1200	12.0	14.0	19.0	28.0	35.0	45.0	56.0	79.0	100	115	144	196	221	256	307	384	442	538	602
	1000	10.0	12.0	16.0	22.0	29.0	38.0	47.0	65.0	83.0	96.0	120	163	185	213	256	320	368	448	502
112	1800	16.1	19.0	27.0	37.0	46.0	61.0	76.0	105	134	155	194	262	297	344	412	515*	593*	722*	808*
	1500	13.4	16.0	21.0	31.0	39.0	51.0	63.0	88.0	111	130	161	218	247	286	343	428	494	601	672
	1200	10.7	12.0	17.0	25.0	31.0	40.0	50.0	70.0	89.0	103	129	174	197	228	273	343	394	479	537
	1000	8.9	10.0	14.0	20.0	26.0	34.0	42.0	58.0	73.0	86.0	107	145	164	190	227	285	327	399	447
125	1800	14.4	17.0	24.0	33.0	42.0	54.0	67.0	94.0	119	139	173	235	265	307	368	461*	530*	646*	722*
	1500	12.0	14.0	19.0	28.0	35.0	45.0	56.0	79.0	100	115	144	196	221	256	307	384	442	538	602
	1200	9.6	11.0	15.0	21.0	28.0	36.0	45.0	62.0	80.0	93.0	115	156	176	205	246	307	353	430	481
	1000	8.0	10.0	12.0	18.0	22.0	30.0	38.0	52.0	66.0	77.0	96.0	131	147	170	205	256	295	358	401
140	1800	12.9	15.0	20.0	30.0	37.0	49.0	60.0	85.0	107	124	155	210	238	275	330	413*	475*	578*	647*
	1500	10.7	12.0	17.0	25.0	31.0	40.0	50.0	70.0	89.0	103	129	174	197	228	273	343	394	479	537
	1200	8.6	10.0	13.0	19.0	24.0	33.0	40.0	56.0	71.0	83.0	103	140	158	184	220	275	316	386	431
	1000	7.1	9.0	11.0	16.0	20.0	27.0	33.0	46.0	58.0	68.3	86.0	115	131	151	182	227	261	318	356
160	1800	11.3	13.0	18.0	26.0	33.0	43.0	53.0	73.0	94.0	109	136	185	208	241	289	361*	416*	506*	567*
	1500	9.4	11.0	15.0	21.0	27.0	36.0	44.0	61.0	78.0	91.0	113	153	173	200	241	301	346	421	471
	1200	7.5	9.0	12.0	17.0	21.0	29.0	35.0	49.0	62.0	72.0	90.0	122	138	160	192	240	275	336	376
	1000	6.3	8.0	10.0	14.0	17.0	24.0	30.0	41.0	52.0	60.0	76.0	102	116	134	161	201	232	283	316
180	1800	10.0	12.0	16.0	22.0	29.0	38.0	47.0	65.0	83.0	96.0	120	163	185	213	256	320*	368*	448*	502*
	1500	8.3	10.0	13.0	18.0	24.0	32.0	39.0	54.0	68.0	80.0	100	135	153	176	212	265	305	372	416
	1200	6.7	8.0	10.0	15.0	19.0	26.0	32.0	44.0	55.0	64.0	81.0	109	123	143	171	214	247	300	336
	1000	5.6	7.0	9.0	12.0	15.0	20.0	26.0	37.0	46.0	54.0	67.0	91.0	103	119	143	179	206	251	281
200	1800	9.0	10.0	14.0	20.0	26.0	34.0	42.0	59.0	75.0	87.0	108	147	166	192	231	288*	332*	403*	451*
	1500	7.5	9.0	12.0	17.0	21.0	29.0	35.0	49.0	62.0	72.0	90.0	122	138	160	192	240	275	336	376
	1200	6.0	7.0	10.0	13.0	17.0	22.0	28.0	39.0	50.0	57.0	71.0	98.0	110	128	153	192	220	268	301
	1000	5.0	6.0	8.0	11.0	14.0	18.0	24.0	33.0	41.0	48.0	60.0	82.0	92.0	106	128	160	184	223	251
224	1800	8.0	10.0	12.0	18.0	22.0	30.0	38.0	52.0	66.0	77.0	96.0	131	147	170	205	256*	295*	358*	401*
	1500	6.7	8.0	10.0	15.0	19.0	26.0	32.0	44.0	55.0	64.0	81.0	109	123	143	171	214	247	300	336
	1200	5.4	7.0	9.0	12.0	15.0	20.0	25.0	35.0	45.0	52.0	64.0	88.0	99.0	115	138	172	199	242	270
	1000	4.5	6.0	7.0	10.0	12.0	16.0	20.0	30.0	37.0	43.0	54.0	73.0	83.0	96.0	115	144	165	201	225
250	1800	7.2	9.0	11.0	16.0	20.0	27.0	34.0	47.0	59.0	69.0	87.0	117	133	153	184	231*	265*	322*	361*
	1500	6.0	7.0	10.0	13.0	17.0	22.0	28.0	39.0	50.0	57.0	71.0	98.0	110	128	153	192	220	268	301
	1200	4.8	6.0	8.0	10.0	13.0	17.0	22.0	31.0	40.0	46.0	57.0	78.0	88.0	102	122	153	176	215	241
	1000	4.0	5.0	7.0	9.0	11.0	14.0	18.0	26.0	33.0	38.0	48.0	65.0	73.0	85.0	102	128	147	179	200
280	1800	6.4	8.0	10.0	14.0	18.0	24.0	30.0	42.0	53.0	61.0	77.0	104	117	137	163	205*	236*	287*	320*
	1500	5.4	7.0	9.0	12.0	15.0	19.0	25.0	35.0	45.0	52.0	64.0	88.0	99.0	115	138	172	199	242	270
	1200	4.3	5.0	7.0	10.0	12.0	15.0	19.0	28.0	36.0	41.0	51.0	69.0	79.0	92.0	110	138	158	193	215
	1000	3.6	4.0	6.0	8.0	10.0	13.0	16.0	24.0	30.0	35.0	43.0	58.0	66.0	77.0	92	115	133	161	181
315	1800	5.7	7.0	9.0	12.0	16.0	20.0	27.0	36.0	47.0	55.0	68.0	93.0	105	121	146	183*	209*	255*	286*
	1500	4.8	6.0	8.0	10.0	13.0	17.0	22.0	31.0	40.0	46.0	57.0	78.0	88.0	102	122	153	176	215	241
	1200	3.8	5.0	6.0	8.0	10.0	13.0	17.0	24.0	32.0	37.0	45.0	61.0	69.0	81.0	97.0	121	140	170	191
	1000	3.2	4.0	5.0	7.0	9.0	11.0	14.0	20.0	27.0	31.0	38.0	52.0	58.0	68.0	82.0	102	117	143	160
355	1800	5.1	-	8.0	-	14.0	-	24.0	-	42.0	-	61.0	-	94.0	-	131	-	188*	-	255*
	1500	4.2	-	7.0	-	11.0	-	19.0	-	35.0	-	50.0	-	78.0	-	107	-	154	-	210
	1200	3.4	-	6.0	-	10.0	-	15.0	-	28.0	-	41.0	-	62.0	-	87.0	-	124	-	170
	1000	2.8	-	5.0	-	8.0	-	12.0	-	22.0	-	34.0	-	51.0	-	71.0	-	103	-	140
400	1800	4.5	-	7.0	-	12.0	-	20.0	-	36.0	-	54.0	-	-	-	-	-	-	-	-
	1500	3.8	-	6.0	-	10.0	-	17.0	-	30.0	-	45.0	-	-	-	-	-	-	-	-
	1200	3.0	-	5.0	-	8.0	-	13.0	-	24.0	-	36.0	-	-	-	-	-	-	-	-
	1000	2.5	-	4.0	-	7.0	-	11.0	-	19.0	-	30.0	-	-	-	-	-	-	-	-

■ Yatay redüktörlerde basınçlı yağlama gereklidir.

■ Forced lubrication required on horizontal gear units

■ Druckschmierung bei Horizontalgetrieben erforderlich

□ * Talep edildiğinde yapılan redüktörler.

□ * Gear units only on request

□ * Getriebe nur auf Anfrage

TR NOMİNAL ÇIKIŞ MOMENTLERİ T_{2N} (kNm)

EN NOMINAL OUTPUT TORQUES T_{2N} (kNm)

DE NENN-ABTRIEBSDREHMOMENTE T_{2N} (kNm)

İN	Redüktör Gövdeleri / Gear unit sizes / Getriebegrößen																	
	54	64	74	84	94	104	114	124	134	144	154	164	174	184	194	204	214	224
80.0	11.8	-	22.1	-	36.4	-	62.8	-	92.5	-	156	-	204	-	306	-	428	-
90.0	11.8	-	22.1	-	36.4	-	62.8	-	92.5	-	156	176	204	245	306	352	428	479
100	11.8	15.8	22.1	27.7	36.4	45.1	62.8	79.6	92.5	115	156	176	204	245	306	352	428	479
112	11.8	15.8	22.1	27.7	36.4	45.1	62.8	79.6	92.5	115	156	176	204	245	306	352	428	479
125	11.8	15.8	22.1	27.7	36.4	45.1	62.8	79.6	92.5	115	156	176	204	245	306	352	428	479
140	11.8	15.8	22.1	27.7	36.4	45.1	62.8	79.6	92.5	115	156	176	204	245	306	352	428	479
160	11.8	15.8	22.1	27.7	36.4	45.1	62.8	79.6	92.5	115	156	176	204	245	306	352	428	479
180	11.8	15.8	22.1	27.7	36.4	45.1	62.8	79.6	92.5	115	156	176	204	245	306	352	428	479
200	11.8	15.8	22.1	27.7	36.4	45.1	62.8	79.6	92.5	115	156	176	204	245	306	352	428	479
224	11.8	15.8	22.1	27.7	36.4	45.1	62.8	79.6	92.5	115	156	176	204	245	306	352	428	479
250	11.8	15.8	22.1	27.7	36.4	45.1	62.8	79.6	92.5	115	156	176	204	245	306	352	428	479
280	11.8	15.8	22.1	27.7	36.0	45.1	62.8	79.6	92.5	115	156	176	204	245	306	352	428	479
315	11.4	15.8	20.9	27.7	34.7	45.1	61.2	79.6	92.5	115	156	176	204	245	306	352	428	479
355	-	15.8	-	27.0	-	45.1	-	79.6	-	115	-	176	-	245	-	352	-	479
400	-	14.8	-	26.0	-	43.9	-	76.5	-	115	-	-	-	-	-	-	-	-

TR TERMAL KAPASİTELER Pt (kW)

EN THERMAL CAPACITIES Pt (kW)

DE WÄRMEGRENZLEISTUNGEN Pt (kW)

İN	Pt (kW)	Redüktör Gövdeleri / Gear unit sizes / Getriebegrößen																n ₁ =1000 min ⁻¹	
		54	64	74	84	94	104	114	124	134	144	154	164	174	184	194	204	214	224
80.0	Pt1	29.2	-	43.2	-	61.0	-	92.4	-	123	-	165	-	187	-	255	-	358	-
90.0	Pt1	28.5	-	41.8	-	60.0	-	89.7	-	120	-	158	170	179	192	245	261	346	362
100	Pt1	27.1	31.2	39.6	46.2	57.0	61.6	86.1	103	114	133	149	163	167	184	232	251	325	351
112	Pt1	26.1	30.5	38.1	44.9	55.0	60.2	82.0	100	109	129	142	154	160	172	220	237	315	328
125	Pt1	25.0	29.2	36.4	42.4	52.0	57.1	78.5	95.1	104	121	135	147	152	164	209	225	297	319
140	Pt1	23.9	28.1	34.6	40.9	49.0	55.0	74.3	90.6	100	116	131	140	147	157	202	215	287	300
160	Pt1	21.9	26.8	31.5	39.0	45.0	52.3	67.7	86.8	94.2	112	123	135	139	151	191	207	270	290
180	Pt1	21.5	25.6	30.7	37.1	44.0	49.7	65.9	82.2	88.9	105	116	126	131	142	179	195	253	274
200	Pt1	20.8	23.6	30.5	33.9	43.0	45.5	64.5	75.1	86.9	100	114	119	129	135	177	183	245	256
224	Pt1	19.4	23.2	28.4	33.0	40.0	44.3	60.6	73.2	81.5	95.1	107	118	119	133	166	183	228	248
250	Pt1	18.9	22.2	27.4	32.7	39.0	43.4	58.7	71.5	78.8	92.4	104	110	116	124	161	171	221	232
280	Pt1	18.0	20.8	25.7	30.6	37.0	40.6	56.1	67.1	74.5	86.9	96.9	106	109	119	151	164	211	224
315	Pt1	16.8	20.2	24.1	29.4	35.0	39.2	52.3	65.0	71.0	84.0	91.5	100	103	112	143	156	197	214
355	Pt1	-	19.4	-	27.6	-	37.3	-	62.0	-	79.4	-	94.2	-	106	-	147	-	200
400	Pt1	-	18.1	-	25.9	-	35.2	-	57.8	-	75.6	-	-	-	-	-	-	-	-

İN	Pt (kW)	Redüktör Gövdeleri / Gear unit sizes / Getriebegrößen																n ₁ =1200 min ⁻¹	
		54	64	74	84	94	104	114	124	134	144	154	164	174	184	194	204	214	224
80.0	Pt1	31.1	-	46.0	-	65.0	-	96.8	-	128	-	168	-	187	-	253	-	341	-
90.0	Pt1	30.5	-	44.6	-	63.0	-	94.1	-	125	-	162	173	180	193	245	260	334	343
100	Pt1	29.1	33.4	42.2	49.2	60.0	65.4	90.7	108	119	138	153	166	170	186	233	252	317	337
112	Pt1	28.1	32.6	40.7	47.8	58.0	64.0	86.6	104	114	135	147	158	164	176	223	240	312	320
125	Pt1	26.8	31.2	39.0	45.3	55.0	60.9	83.1	100	110	128	141	152	157	169	214	231	297	315
140	Pt1	25.6	30.1	37.0	43.8	52.0	58.7	78.8	96.0	105	122	137	146	152	162	208	221	290	300
160	Pt1	23.6	28.8	33.9	41.8	48.0	56.0	72.1	92.2	100	118	130	141	145	158	198	214	276	294
180	Pt1	23.2	27.5	33.0	39.8	47.0	53.2	70.4	87.6	94.7	112	122	134	138	149	187	204	261	282
200	Pt1	22.3	25.4	32.7	36.4	46.0	48.8	69.1	80.3	92.8	107	121	128	137	143	187	193	256	266
224	Pt1	20.8	24.9	30.6	35.6	43.0	47.6	65.1	78.5	87.3	102	114	125	128	141	177	194	242	261
250	Pt1	20.4	24.0	29.6	35.3	42.0	46.7	63.1	76.9	84.8	99.3	111	118	124	134	172	184	237	248
280	Pt1	19.4	22.4	27.7	32.9	40.0	43.9	60.5	72.4	80.4	93.8	104	115	117	130	163	177	228	242
315	Pt1	18.2	21.8	26.0	31.7	37.0	42.3	56.5	70.1	76.7	90.8	98.8	108	111	121	155	168	213	232
355	Pt1	-	20.9	-	29.8	-	40.4	-	66.9	-	85.7	-	102	-	115	-	158	-	215
400	Pt1	-	19.5	-	27.9	-	38.0	-	62.4	-	81.6	-	-	-	-	-	-	-	-

Pt1 (kW) İlave soğutmasız redüktörler **)

**) Değerlere Bakınız:

Saatlik çalışma döngüsü: %100

Büyük bir alanda kurulum

Rakım 1000m'ye kadar

Pt1(kW)Gear units without auxiliary cooling**)

**) Values refer to:

Operating cycle: 100%

Installation in a large hall

Altitude up to 1000 m

Pt1 (kW) Getriebe ohne Zusatzkühlung**)

**) Werte gelten für:

Einschaltdauer: 100 %

Aufstellun in großer Halle

Höhenlage bis 1000 m

TR TERMAL KAPASİTELER Pt (kW)

EN THERMAL CAPACITIES Pt (kW)

DE WÄRMEGRENZLEISTUNGEN Pt (kW)

İN	Pt (kW)	Redüktör Gövdeleri / Gear unit sizes / Getriebegrößen																n ₁ =1500 min ⁻¹		
		54	64	74	84	94	104	114	124	134	144	154	164	174	184	194	204	214	224	
80.0	Pt1	32.3	-	47.8	-	67.0	-	101	-	133	-	174	-	193	-	261	-	350	-	
90.0	Pt1	31.7	-	46.4	-	66.0	-	97.8	-	131	-	167	179	187	199	253	269	344	352	
100	Pt1	30.2	34.7	44.0	51.2	63.0	68.0	94.2	112	123	143	159	172	176	192	241	260	327	346	
112	Pt1	29.2	34.0	42.3	49.8	60.0	66.6	90.1	108	118	140	152	164	170	183	232	248	321	329	
125	Pt1	27.9	32.4	40.5	47.1	58.0	63.3	86.5	104	114	133	146	158	162	175	222	239	306	324	
140	Pt1	26.6	31.3	38.6	45.5	55.0	61.1	82.0	100	109	128	142	151	158	168	215	230	300	310	
160	Pt1	24.6	30.0	35.2	43.6	50.0	58.3	75.1	96.0	103	123	135	146	150	163	206	222	287	304	
180	Pt1	24.1	28.7	34.4	41.5	49.0	55.4	73.2	91.1	98.4	116	128	139	143	155	194	212	271	292	
200	Pt1	23.3	26.4	34.2	37.9	48.0	50.8	71.9	83.5	96.6	111	126	133	142	149	195	200	265	276	
224	Pt1	21.7	25.9	31.8	37.1	45.0	49.6	67.8	81.8	90.9	106	119	131	133	147	185	202	251	271	
250	Pt1	21.2	25.0	30.8	36.7	43.0	48.8	65.8	80.2	88.3	103	116	122	130	139	180	191	246	257	
280	Pt1	20.2	23.4	29.0	34.4	41.0	45.7	63.0	75.5	83.7	97.8	108	119	122	135	170	186	238	252	
315	Pt1	19.0	22.7	27.1	33.0	39.0	44.1	59.0	73.0	80.0	94.6	102	112	115	126	161	175	221	241	
355	Pt1	-	21.7	-	31.0	-	42.0	-	69.8	-	89.4	-	105	-	119	-	165	-	224	
400	Pt1	-	20.3	-	29.2	-	39.7	-	65.1	-	85.1	-	-	-	-	-	-	-	-	

İN	Pt (kW)	Redüktör Gövdeleri / Gear unit sizes / Getriebegrößen																n ₁ =1800 min ⁻¹		
		54	64	74	84	94	104	114	124	134	144	154	164	174	184	194	204	214	224	
80.0	Pt1	33.7	-	49.6	-	69.0	-	102	-	133	-	171	-	188	-	250	-	318	-	
90.0	Pt1	32.9	-	48.1	-	68.0	-	99.9	-	132	-	166	176	182	194	244	258	317	317	
100	Pt1	31.5	36.1	45.7	53.0	65.0	70.2	96.6	114	125	145	158	171	173	189	235	252	307	318	
112	Pt1	30.4	35.4	44.1	51.6	63.0	68.9	92.5	111	120	142	153	164	168	181	227	243	306	308	
125	Pt1	29.1	33.9	42.2	49.0	60.0	65.6	89.0	107	116	136	147	158	163	174	220	236	296	309	
140	Pt1	27.8	32.6	40.2	47.4	57.0	63.4	84.8	102	111	131	144	153	159	169	216	228	294	300	
160	Pt1	25.7	31.3	36.8	45.4	52.0	60.7	77.7	99.1	106	126	138	149	153	165	208	224	284	298	
180	Pt1	25.2	30.0	35.9	43.4	51.0	57.7	76.1	94.5	102	120	132	143	146	158	198	215	271	291	
200	Pt1	24.4	27.6	35.7	39.7	50.0	53.0	74.9	86.9	100	115	131	137	146	153	200	205	269	279	
224	Pt1	22.7	27.2	33.4	38.9	47.0	51.9	70.9	85.4	94.8	110	123	136	138	152	191	209	258	278	
250	Pt1	22.2	26.2	32.3	38.6	45.0	51.1	69.0	83.9	92.4	108	121	129	136	145	188	199	256	267	
280	Pt1	21.3	24.6	30.4	36.1	44.0	48.0	66.3	79.3	88.0	102	114	125	129	142	179	195	250	265	
315	Pt1	19.9	24.0	28.5	34.8	41.0	46.3	61.9	76.7	83.9	99.3	108	118	121	134	169	184	233	253	
355	Pt1	-	22.8	-	32.6	-	44.2	-	73.2	-	93.8	-	111	-	125	-	173	-	236	
400	Pt1	-	21.4	-	30.6	-	41.6	-	68.3	-	89.4	-	-	-	-	-	-	-	-	

Pt1 (kW) İlave soğutmasız redüktörler **)

**) Değerlere Bakınız:

Saatlik çalışma döngüsü: %100

Büyük bir alanda kurulum

Rakım 1000m'ye kadar

Pt1(kW)Gear units without auxiliary cooling**)

**) Values refer to:

Operating cycle: 100%

Installation in a large hall

Altitude up to 1000 m

Pt1 (kW) Getriebe ohne Zusatzkühlung**)

**) Werte gelten für:

Einschaltdauer: 100 %

Aufstellun in großer Halle

Höhenlage bis 1000 m

TR GERÇEK TAHVİLLER (i)

EN ACTUAL RATIOS (i)

DE IST - ÜBERSETZUNGEN (i)

İN	31	41	51	61	71	81	91	101	111	121
1.25	1.243	-	1.256	-	1.263	-	1.270	-	-	-
1.4	1.371	-	1.378	-	1.389	-	1.400	-	-	-
1.6	1.594	-	1.588	-	1.606	-	1.625	-	1.636	-
1.8	1.829	-	1.839	-	1.774	-	1.800	-	1.806	-
2.0	2.000	-	2.034	-	1.966	-	2.000	-	2.000	-
2.24	2.194	-	2.259	-	2.308	-	2.231	-	2.222	-
2.5	2.536	-	2.520	-	2.583	-	2.500	-	2.480	-
2.8	2.808	-	2.826	-	2.800	-	2.741	-	2.783	-
3.15	3.125	-	3.190	-	3.130	-	3.208	-	3.080	-
3.55	3.500	-	3.591	-	3.524	-	3.591	-	3.478	-
4.0	3.950	-	4.050	-	4.000	-	4.050	-	3.905	-
4.5	4.435	-	4.619	-	4.400	-	4.381	-	4.421	-
5.0	4.952	-	4.900	-	4.905	-	4.947	-	5.150	-
5.6	5.579	-	5.556	-	5.526	-	5.684	-	5.474	-

İN		42	52	62	72	82	92	102	112	122
6.3	-	6.319	6.286	-	6.088	-	6.260	-	6.246	-
7.1	-	6.857	7.213	-	7.048	-	7.247	-	6.900	-
8.0	-	7.778	7.889	7.792	7.799	7.676	8.018	7.848	7.644	7.941
9.0	-	8.485	8.652	8.940	8.660	8.887	8.904	9.085	8.974	8.772
10.0	-	9.722	10.002	9.778	9.660	9.833	9.932	10.053	10.046	9.718
11.2	-	10.694	11.075	10.724	10.648	10.920	11.138	11.163	10.889	11.410
12.5	-	12.444	12.326	12.397	11.807	12.180	12.574	12.452	12.174	12.773
14.0	-	13.865	13.806	13.726	13.939	13.426	14.152	13.964	13.704	13.844
16.0	-	15.556	15.581	15.278	15.717	14.887	15.962	15.765	15.556	15.478
18.0	-	17.602	17.493	17.111	17.598	17.576	18.204	17.743	17.111	17.423
20.0	-	19.444	19.534	19.311	19.742	19.817	19.312	20.012	19.074	19.778
22.4	-	22.037	22.006	21.681	20.982	22.189	21.895	22.824	21.491	21.756
25.0	-	-	-	24.212	-	24.892	-	24.212	-	24.251
28.0	-	-	-	27.275	-	26.456	-	27.451	-	27.325

İN			53	63	73	83	93	103	113	123
25.0	-	-	25.011	-	25.540	-	25.439	-	24.706	-
28.0	-	-	28.490	-	27.711	-	29.187	-	28.602	-
31.5	-	-	31.161	30.999	31.433	32.202	31.924	31.894	31.648	31.412
35.5	-	-	34.177	35.312	34.291	34.940	35.013	36.593	35.144	36.366
40.0	-	-	39.508	38.622	39.292	39.633	40.474	40.024	39.200	40.238
45.0	-	-	43.745	42.360	43.221	43.236	44.816	43.897	43.210	44.683
50.0	-	-	48.689	48.967	50.293	49.542	49.881	50.744	47.911	49.840
56.0	-	-	54.532	54.220	56.033	54.496	55.866	56.187	56.566	54.938
63.0	-	-	61.543	60.347	62.867	63.413	63.049	62.537	63.778	60.916
71.0	-	-	69.742	67.589	71.139	70.651	70.787	70.041	71.414	71.919
80.0	-	-	78.723	76.279	78.583	79.267	79.049	79.046	80.111	81.089
90.0	-	-	86.806	86.440	89.061	89.696	89.050	88.748	85.146	90.798
100	-	-	-	97.572	-	99.083	-	99.106	-	101.856
112	-	-	-	107.590	-	112.294	-	111.645	-	108.257

İN					74	84	94	104	114	124
100	-	-	-	-	101.554	-	101.210	-	103.639	-
112	-	-	-	-	115.256	-	115.290	-	112.450	-
125	-	-	-	-	125.733	128.046	126.098	126.890	127.556	131.769
140	-	-	-	-	143.985	145.322	138.301	144.542	139.152	142.973
160	-	-	-	-	158.251	158.533	159.874	158.093	159.444	162.178
180	-	-	-	-	174.630	181.546	177.022	173.392	175.389	176.921
200	-	-	-	-	193.629	199.533	197.028	200.439	204.089	202.722
224	-	-	-	-	228.606	220.185	220.671	221.938	227.382	222.994
250	-	-	-	-	257.753	244.141	249.043	247.020	255.111	259.484
280	-	-	-	-	288.615	288.242	282.219	276.663	288.678	289.100
315	-	-	-	-	305.352	324.993	318.563	312.234	318.889	324.356
355	-	-	-	-	344.112	363.906	351.273	353.827	361.407	367.034
400	-	-	-	-	-	385.010	-	399.393	-	405.444
450	-	-	-	-	-	433.881	-	440.402	-	459.504

TR GERÇEK TAHVİLLER (i)

EN ACTUAL RATIOS (i)

DE IST - ÜBERSETZUNGEN (i)

İN	131	141	151	161	171	181	191	201	211	221
1.25	-	-	-	-	-	-	-	-	-	-
1.4	-	-	-	-	-	-	-	-	-	-
1.6	1.588	-	-	-	-	-	-	-	-	-
1.8	1.839	-	-	-	-	-	-	-	-	-
2.0	2.034	-	2.000	-	2.000	-	1.967	-	-	-
2.24	2.259	-	2.231	-	2.250	-	2.296	-	-	-
2.5	2.520	-	2.481	-	2.481	-	2.560	-	-	-
2.8	2.826	-	2.760	-	2.760	-	2.870	-	-	-
3.15	3.208	-	3.087	-	3.087	-	3.238	-	-	-
3.55	3.591	-	3.476	-	3.476	-	3.450	-	-	-
4.0	4.050	-	3.947	-	3.947	-	3.944	-	-	-
4.5	4.619	-	4.579	-	4.526	-	4.400	-	-	-
5.0	4.900	-	5.100	-	4.900	-	4.950	-	-	-
5.6	5.556	-	5.778	-	5.556	-	5.700	-	-	-

İN	132	142	152	162	172	182	192	202	212	222
6.3	6.410	-	6.449	-	6.154	-	6.410	-	6.500	-
7.1	7.100	-	7.120	7.316	7.125	7.147	7.100	7.312	7.200	7.265
8.0	7.889	7.944	7.882	8.076	7.884	8.274	7.889	8.100	8.000	8.047
9.0	8.799	8.800	8.758	8.941	8.755	9.155	8.799	9.000	8.923	8.941
10.0	9.861	9.778	9.774	9.935	9.765	10.167	9.788	10.038	9.926	9.973
11.2	10.811	10.906	10.967	11.087	10.951	11.340	10.887	11.167	11.040	11.094
12.5	12.655	12.222	12.139	12.440	12.432	12.717	12.176	12.420	12.348	12.339
14.0	14.164	13.399	13.708	13.769	13.915	14.438	13.712	13.891	13.905	13.801
16.0	15.975	15.685	15.389	15.550	15.694	16.159	15.570	15.643	15.789	15.541
18.0	17.280	17.556	17.424	17.457	17.899	18.225	18.061	17.763	18.316	17.647
20.0	19.515	19.800	20.297	19.765	18.988	20.786	20.117	20.605	20.400	20.471
22.4	-	21.418	-	23.024	-	22.050	-	22.950	-	22.800
25.0	-	24.187	-	-	-	-	-	-	-	-

İN	133	143	153	163	173	183	193	203	213	223
22.4	22.020	-	21.374	-	20.930	-	21.782	-	22.368	-
25.0	25.372	-	24.716	24.245	24.202	24.306	25.283	24.850	25.837	25.000
28.0	29.373	27.292	27.304	28.036	26.736	28.106	28.006	28.844	28.523	28.877
31.5	32.501	31.447	30.248	30.971	29.619	31.048	31.117	31.950	31.579	31.879
35.5	36.092	36.406	35.514	34.311	34.776	34.397	34.708	35.500	35.088	35.294
40.0	40.257	40.283	39.756	40.284	38.929	40.385	38.897	39.596	39.158	39.216
45.0	45.147	44.733	43.090	45.096	42.194	45.208	42.642	44.375	43.936	43.765
50.0	50.968	49.896	48.175	48.878	47.174	49.000	49.917	48.648	48.632	49.105
56.0	57.365	55.957	54.229	54.647	53.102	54.783	55.870	56.948	54.920	54.353
63.0	64.699	63.171	61.557	61.514	60.278	61.667	63.013	63.739	61.654	61.381
71.0	73.789	71.100	67.713	69.826	66.306	70.000	68.162	71.888	69.806	68.908
80.0	78.278	80.190	75.481	76.809	73.912	77.000	76.974	77.762	81.316	78.019
90.0	88.750	91.457	85.046	85.620	83.279	85.833	88.439	87.816	86.427	90.882
100	-	97.020	-	96.471	-	96.711	-	100.895	-	96.594
112	-	110.000	-	-	-	-	-	-	-	-

İN	134	144	154	164	174	184	194	204	214	224
100	103.114	-	97.768	-	95.735	-	100.079	-	99.020	-
112	118.306	-	113.186	110.901	110.833	111.176	115.862	114.174	109.386	110.670
125	129.398	127.803	125.238	128.390	122.634	128.710	128.198	132.180	121.182	122.255
140	141.920	146.633	139.074	142.060	136.183	142.414	142.362	146.254	142.279	135.439
160	164.058	160.380	155.125	157.756	151.900	158.148	158.792	162.413	159.273	159.017
180	181.654	175.901	170.993	175.962	167.438	176.400	178.079	181.156	172.632	178.011
200	202.184	203.339	189.597	193.962	185.656	194.444	201.040	203.160	193.004	192.941
224	226.446	225.149	223.845	215.065	219.192	215.600	226.272	229.355	217.257	215.711
250	255.560	250.594	252.385	253.914	247.139	254.545	255.201	258.141	246.617	242.817
280	286.925	280.665	282.605	286.288	276.730	287.000	291.058	291.144	271.278	275.630
315	320.413	316.751	317.021	320.566	310.431	321.364	308.761	332.052	302.399	303.193
355	360.951	355.625	336.946	359.606	329.942	360.500	350.069	352.249	340.720	337.975
400	-	397.131	-	382.207	-	383.158	-	399.375	-	380.805
450	-	447.376	-	-	-	-	-	-	-	-

TR GERÇEK TAHVİLLER (i)

EN ACTUAL RATIOS (i)

DE IST - ÜBERSETZUNGEN (i)

İN	42	52	62	72	82	92	102	112	122
5.0	4.936	5.006	-	4.865	-	5.002	-	4.897	-
5.6	5.480	5.488	-	5.333	-	5.483	-	5.534	-
6.3	6.296	6.386	6.205	6.206	6.135	6.381	6.271	6.296	6.226
7.1	6.959	7.058	6.802	6.860	6.725	7.053	6.875	7.037	7.036
8.0	7.549	7.657	7.915	7.880	7.825	8.101	8.000	7.994	8.005
9.0	8.693	8.817	8.749	8.569	8.649	8.810	8.842	8.693	8.947
10.0	9.872	10.108	9.490	9.823	9.935	10.099	10.157	9.965	10.164
11.2	10.769	10.923	10.928	10.615	10.804	10.914	11.045	10.769	11.052
12.5	-	-	12.528	-	12.385	-	12.662	-	12.670
14.0	-	-	13.538	-	13.385	-	13.683	-	13.692

İN	43	53	63	73	83	93	103	113	123
12.5	12.034	12.703	-	12.433	-	12.554	-	12.334	-
14.0	13.484	13.964	-	13.515	-	14.137	-	13.821	-
16.0	15.601	15.835	15.826	16.275	15.773	15.952	15.693	15.522	15.888
18.0	17.482	17.407	17.307	17.692	17.041	17.963	17.724	17.393	17.572
20.0	19.614	19.645	19.729	19.948	20.648	20.259	19.940	19.744	19.995
22.4	21.919	21.954	21.575	22.146	22.308	22.208	22.520	21.643	22.114
25.0	25.380	25.421	24.349	25.446	25.152	25.843	25.400	25.185	25.103
28.0	27.836	27.881	27.211	28.125	27.923	28.563	27.842	27.836	27.517
31.5	30.196	30.245	31.508	30.509	32.084	30.985	32.400	31.975	32.021
35.5	34.771	34.827	34.557	35.131	35.461	35.679	35.811	34.771	35.392
40.0	39.487	39.551	37.486	39.896	38.468	40.902	38.846	39.861	40.654
45.0	43.077	43.146	43.166	43.523	44.296	44.202	44.732	43.077	44.209
50.0	49.060	49.139	49.021	49.568	50.304	50.341	51.280	49.060	50.681
56.0	55.152	55.240	53.477	55.723	54.877	56.592	55.417	55.152	54.769
63.0	60.808	60.906	60.904	61.438	62.499	62.396	63.114	60.808	62.376
71.0	69.293	69.404	68.467	70.011	70.259	71.102	70.951	69.293	70.121
80.0	-	-	75.489	-	77.465	-	78.228	-	77.313
90.0	-	-	86.022	-	88.274	-	89.143	-	88.101

İN	54	64	74	84	94	104	114	124	
80.0	-	77.598	-	79.267	-	79.497	-	80.949	-
90.0	-	86.720	-	88.585	-	88.842	-	89.869	-
100	-	100.413	96.178	102.572	99.945	102.869	99.667	103.259	102.921
112	-	110.130	107.484	112.498	111.694	112.824	111.384	114.129	114.262
125	-	119.466	124.455	122.035	129.330	122.389	128.971	123.804	131.287
140	-	137.567	136.499	140.525	141.846	140.933	141.452	142.562	145.106
160	-	156.225	148.071	159.585	153.871	160.047	153.443	161.897	157.408
180	-	170.427	170.506	174.092	177.184	174.597	176.692	176.615	181.258
200	-	194.098	193.631	198.272	201.215	198.847	200.656	201.145	205.841
224	-	218.199	211.234	222.891	219.508	223.537	218.898	226.121	224.554
250	-	240.578	240.572	245.752	249.995	246.464	249.300	249.313	255.742
280	-	274.147	270.443	280.042	281.036	280.855	280.256	284.101	287.497
315	-	302.121	298.181	308.618	309.861	309.513	309.000	313.091	316.984
355	-	-	339.788	-	353.097	-	352.116	-	361.214
400	-	-	374.460	-	389.127	-	388.046	-	398.073

TR

GERÇEK TAHVİLLER (i)

EN

ACTUAL RATIOS (i)

DE

IST - ÜBERSETZUNGEN (i)

iN	132	142	152	162	172	182	192	202	212	222
5.0	4.967	-	4.963	-	-	-	-	-	-	-
5.6	5.613	-	5.609	5.630	5.514	-	-	-	-	-
6.3	6.386	6.156	6.340	6.362	6.234	-	-	-	-	-
7.1	7.138	6.957	7.132	7.192	7.012	7.239	-	-	-	-
8.0	8.108	7.915	8.101	8.090	7.965	8.143	-	-	-	-
9.0	8.817	8.847	8.810	9.190	8.662	9.250	-	-	-	-
10.0	10.108	10.049	10.099	9.993	9.930	10.059	-	-	-	-
11.2	10.923	10.928	10.914	11.456	10.731	11.531	-	-	-	-
12.5	-	12.528	-	12.380	-	12.462	-	-	-	-
14.0	-	13.538	-	-	-	-	-	-	-	-

iN	133	143	153	163	173	183	193	203	213	223
12.5	12.482	-	12.172	-	12.770	-	12.062	-	12.256	-
14.0	13.721	-	13.810	13.832	13.790	14.654	13.709	13.698	13.902	13.719
16.0	16.354	15.552	15.215	15.665	16.226	16.014	15.192	15.640	15.436	15.538
18.0	17.978	17.007	17.262	17.290	17.522	18.620	17.267	17.252	17.510	17.279
20.0	20.276	20.376	19.379	19.581	19.762	20.348	19.607	19.698	19.883	19.570
22.4	22.226	22.282	21.900	21.982	22.333	22.950	22.158	22.368	22.470	22.222
25.0	25.864	25.131	24.916	24.842	25.409	25.936	25.048	25.278	25.400	25.113
28.0	28.587	27.548	27.847	28.263	28.398	29.507	28.175	28.576	28.571	28.389
31.5	32.838	32.057	31.634	31.588	32.259	32.979	32.005	32.143	32.456	31.933
35.5	35.709	35.432	34.400	35.883	35.080	37.463	34.804	36.513	35.294	36.275
40.0	40.936	40.700	39.435	39.021	40.215	40.738	39.899	39.706	40.461	39.446
45.0	44.238	44.259	42.617	44.732	43.460	46.702	43.117	45.518	43.725	45.221
50.0	50.383	50.737	48.536	48.341	49.496	50.469	49.106	49.190	49.798	48.869
56.0	56.639	54.831	54.562	55.055	55.641	57.479	55.203	56.022	55.981	55.656
63.0	62.448	62.446	60.158	61.892	61.348	64.616	60.865	62.978	61.722	62.567
71.0	71.161	70.200	68.553	68.239	69.909	71.243	69.358	69.438	70.335	68.984
80.0	-	77.400	-	77.761	-	81.184	-	79.127	-	78.610
90.0	-	88.200	-	-	-	-	-	-	-	-

iN	134	144	154	164	174	184	194	204	214	224
80.0	82.118	-	78.131	-	76.506	-	79.977	-	77.639	-
90.0	90.016	-	85.645	88.626	83.865	88.846	87.670	91.242	87.739	86.772
100	104.750	101.780	99.664	97.150	97.593	97.391	102.020	100.017	99.821	98.061
112	115.777	111.569	110.155	113.052	107.865	113.333	112.759	116.389	111.565	111.565
125	125.592	129.831	126.535	124.952	123.904	125.263	129.526	128.641	126.733	124.690
140	144.621	143.498	137.599	143.532	134.739	143.889	140.851	147.769	137.815	141.643
160	165.791	155.663	157.741	156.082	154.462	156.471	161.470	160.690	157.989	154.029
180	179.166	179.248	170.467	178.930	166.923	179.375	174.496	184.212	170.735	176.576
200	204.050	205.487	194.143	193.365	190.107	193.846	198.732	199.073	194.448	190.821
224	229.386	222.065	218.249	220.222	213.712	220.769	223.408	226.722	218.592	217.324
250	252.913	252.907	240.634	247.566	235.631	248.182	246.322	254.874	241.012	244.309
280	288.204	284.310	274.210	272.957	268.510	273.636	280.692	281.015	274.641	269.366
315	317.612	313.470	302.191	311.045	295.909	311.818	309.334	320.226	302.666	306.952
355	-	357.210	-	342.784	-	343.636	-	352.902	-	338.273
400	-	393.660	-	-	-	-	-	-	-	-

TR ÇIKIŞ MİLİ ÜZERİNDE İZİN VERİLEN
 RADYAL KUVVETLER $d_2^{(1)}$ / (S)

 EN PERMISSIBLE ADDITIONAL RADIAL FORCES
 ON OUTPUT SHAFT $d_2^{(1)}$ / SOLID SHAFT(S)

 DE ZULÄSSIGE RADIALE ZUSATZKRÄFTE AN
 ABTRIEBSWELLE $d_2^{(1)}$ VOLLWELLE (S)

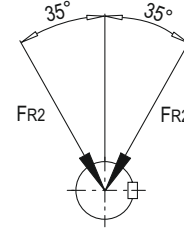
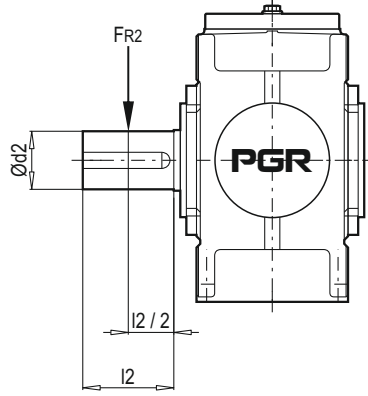
 Milin merkezine uygulanan kuvvet
 Application of force on centre of shaft end
 Kraftangriff auf Mitte Wellenende

 İzin verilen kuvvet yönü
 Permissible direction of force
 Zulässige Krafrichtung

Tablo1 / Table1 / Tabelle1

 Milin merkezinde uygulanacak olan kuvvetler için izin verilen radyal kuvvetler FR2 (kN)
 Permissible additional radial forces FR2 in kN with application of force on centre of shaft end ³⁾
 Zulässige radiale Zusatzkräfte FR2 in kN bei Kraftangriff Mitte Wellenende

Tip Type Bauart	Dizayn Design Ausführung	Redüktör gövdeleri / Gear unit sizes / Getriebegrößen ^{1) 4)}															
		3..	4..	5..	6..	7..	8..	9..	10..	11..	12..	13..	14..	15..	16..	17..	18..
PH..1SH	A / B	2)	–	2)	–	2)	–	2)	–	2)	–	2)	–	2)	–	2)	–
PH..2S	A / B / G / H	–	10	22	22	30	30	30	45	64	64	150	150	140	205	205	205
	C / D	–	10	13	13	18	18	10	28	35	35	112	112	85	135	135	135
PB..2S	A / C	–	13	27	27	37	37	38	55	78	78	160	160	150	210	210	210
	B / D	–	12	15	15	17	17	10	30	35	38	110	110	75	145	100	100
PH..3S	A / B / G / H	–	–	29	29	40	40	40	60	85	85	190	190	185	265	265	265
PH..4S	C / D	–	–	–	–												
PB..3S	A / C	–	14	29	29												
PB..4S	A / C	–	–	–	–	26	26	18	40	50	50	150	150	120	185	185	190
PH..3S	C / D	–	–	18	18												
PH..4S	A / B	–	–	–	–												
PB..3S	B / D	–	9	18	18												
PB..4S	B / D	–	–	–	–												

TR

ÇIKIŞ MİLİ ÜZERİNDE İZİN VERİLEN
RADYAL KUVVETLER $d_2^{(1)}$ / (S)

EN

PERMISSIBLE ADDITIONAL RADIAL FORCES
ON OUTPUT SHAFT $d_2^{(1)}$ / SOLID SHAFT(S)

DE

ZULÄSSIGE RADIALE ZUSATZKRÄFTE AN
ABTRIEBSWELLE $d_2^{(1)}$ VOLLWELLE (S)

Mil merkezinin dışında oluşan
kuvvet uygulamaları
Application of force outside the
centre of the shaft end
Kraftangriff außerhalb Mitte
Wellenende

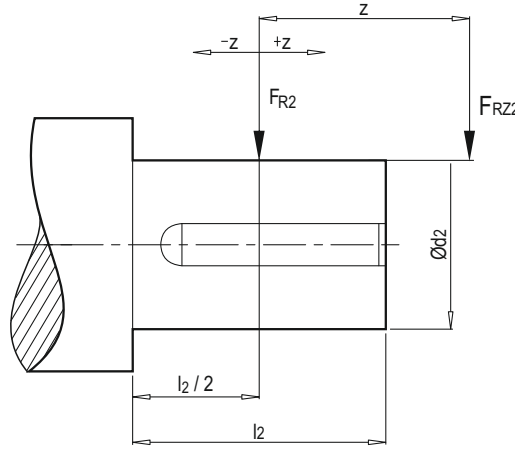

$$F_{R22} = F_{R2} \times k$$

FR22 İzin verilen dış radyal kuvvet
Permissible external radial force
Zulässige äußere Radialkraft

FR2 İzin verilen dış radyal kuvvet
Tablo 1 sayfa 60'a göre
Permissible external radial force
acc. to table 1 Page 60
Zulässige radiale Zusatzkraft ent-
sprechend Tabelle 1 Seite 60

k Tabloya göre kuvvet uygulama
faktörü
Factor of application of force acc.
to table
Kraftangriffsfaktor entsprechend
Tabelle

Tablo2 / Table2 / Tabelle 2

Kuvvet uygulama Faktörü k / Factor of application of force k / Kraftangriffsfaktor k

Gövde Size Größe	Z mesafesi mm / Distance z in mm / Abstand z in mm														
	- 200	- 150	- 100	- 75	- 50	- 25	0	25	50	75	100	150	200	250	300
3					1.21	1.09	1.00	0.85	0.74	0.65	0.58	0.48			
4					1.17	1.08	1.00	0.86	0.76	0.68	0.62	0.52	0.44		
5 + 6				1.22	1.14	1.06	1.00	0.88	0.79	0.72	0.66	0.56	0.49	0.43	
7 + 8				1.19	1.12	1.06	1.00	0.89	0.81	0.74	0.68	0.58	0.51	0.46	0.41
9 + 10			1.22	1.15	1.10	1.05	1.00	0.90	0.82	0.76	0.70	0.61	0.54	0.48	0.44
11 + 12			1.18	1.13	1.08	1.04	1.00	0.91	0.84	0.78	0.73	0.64	0.57	0.51	0.47
13 + 14		1.24	1.15	1.11	1.07	1.03	1.00	0.92	0.86	0.80	0.75	0.67	0.60	0.55	0.50
15 + 16		1.20	1.12	1.09	1.06	1.03	1.00	0.93	0.87	0.82	0.77	0.69	0.63	0.58	0.53
17 + 18	1.25	1.17	1.11	1.08	1.05	1.03	1.00	0.94	0.88	0.84	0.79	0.72	0.66	0.60	0.56

1) Tablo değerleri, en düşük değerlerdir ve $f_1 \geq 1.2$ durumu için geçerlidir. Bir kuvvetin uygulama açısı ve dönme yönü bilindiğinde, genellikle daha yüksek ilave kuvvetlere izin verilebilir. Lütfen, bu konuyu mutlaka PGR ile görüşün.

Gerek varsa, güçlendirilmiş bir çıkış mili kullanılabilir.

- 2) Talep edildiğinde temin edilir.
- 3) Mil ucunun ortasına dıştan kuvvet uygulanması durumu için, lütfen sayfa 61'e bakın.
- 4) Civata kalitesi en az 8.8 olan taban vidaları kullanılır. Zemin, kuru ve yağsız olmalıdır.

1) Values in tables are minimum values. They are valid for $f_1 \geq 1.2$. If the angle of application of force and the direction of rotation are given, significantly higher additional forces can mostly be allowed.

Please consult us.

If necessary, a reinforced output shaft (V) can be used.

- 2) On request
- 3) For application of force outside the centre of the shaft end, see page 61.
- 4) Use foundation bolts of min. property class 8.8 foundation must be dry and grease-free.

1) Tabellenwerte sind Mindestwerte, Sie gelten für $f_1 \geq 1.2$. Unter Angabe von Angriffswinkel und Drehrichtung können meist bedeutend höhere Zusatzkräfte zugelassen werden.

Rücksprache ist erforderlich.

Gegebenfalls ist der Einsatz einer verstärkten Abtriebswelle (V) möglich.

- 2) Auf Anfrage
- 3) Bei Kraftangriff außerhalb Mitte Wellenende siehe Seite 61
- 4) Fußschrauben mit Mindest - Festigkeitsklasse 8.8 verwenden. Fundament muss trocken und fettfrei sein.

Talep edildiğinde:

- d1 Giriş milinde izin verilen ilave radyal kuvvetler,
- Her iki taraftaki çıkış millerinde (E modeli ve I) izin verilen ilave radyal kuvvetler,
- 19 - 22 gövde büyüklükleri için, izin verilen ilave radyal kuvvetler, temin edilir.

On request:

- Permissible additional radial forces on input shaft d_1 .
- Permissible additional radial forces on solid output shafts on both sides (assemblies E, F, and I).
- Permissible additional radial forces for gear unit sizes 19 - 22

Auf Anfrage:

- zulässige radiale Zusatzkräfte an Antriebswelle d_1 .
- zulässige radiale Zusatzkräfte an beidseitigen Abtriebsvollwellen (Ausführungen E, F und I).
- zulässige radiale Zusatzkräfte für die Getriebegrößen 19 - 22.

TR KÜTLE ATALET MOMENTİ J1 (kgm²)

EN MASS MOMENTS OF INERTIA J1 IN kgm²
REFERRING TO SHAFT d1

DE MASSENTRÄGHEITSMOMENTE J1 IN kgm²
BEZOGEN AUF WELLE d1

i _N	Redüktör gövdeleri / Gear unit sizes / Getriebegrößen									
	31	41	51	61	71	81	91	101	111	121
1.25	0.02855	-	0.15709	-	0.42300	-	0.92932	-	-	-
1.4	0.02589	-	0.14349	-	0.38558	-	0.84322	-	-	-
1.6	0.02243	-	0.12352	-	0.33519	-	0.72861	-	1.74977	-
1.8	0.01974	-	0.10903	-	0.30515	-	0.66019	-	1.58798	-
2.0	0.01820	-	0.09932	-	0.27747	-	0.59704	-	1.43757	-
2.24	0.01677	-	0.09029	-	0.23964	-	0.53840	-	1.29698	-
2.5	0.01479	-	0.08187	-	0.21652	-	0.48366	-	1.16495	-
2.8	0.01347	-	0.07398	-	0.20156	-	0.44378	-	1.04055	-
3.15	0.00915	-	0.05006	-	0.14031	-	0.31089	-	0.84211	-
3.55	0.00807	-	0.04369	-	0.12256	-	0.27320	-	0.73595	-
4.0	0.00702	-	0.03797	-	0.10584	-	0.23756	-	0.64640	-
4.5	0.00522	-	0.02975	-	0.08623	-	0.19980	-	0.49550	-
5.0	0.00451	-	0.02756	-	0.07492	-	0.17089	-	0.40618	-
5.6	0.00384	-	0.02332	-	0.06407	-	0.14114	-	0.37471	-
JL	0.060	-	0.045	-	0.100	-	0.100	-	0.290	-
	32	42	52	62	72	82	92	102	112	122
6.3	-	0.01493	0.03380	-	0.09209	-	0.20124	-	0.52103	-
7.1	-	0.01340	0.02812	-	0.07563	-	0.16652	-	0.45488	-
8.0	-	0.01138	0.02503	0.03969	0.06630	0.11062	0.14592	0.23956	0.39684	0.63968
9.0	-	0.01020	0.02227	0.03260	0.05805	0.08946	0.12771	0.19511	0.32236	0.55211
10.0	-	0.00860	0.01857	0.02877	0.05058	0.07759	0.11102	0.16927	0.27967	0.47606
11.2	-	0.00757	0.01619	0.02538	0.04457	0.06721	0.09506	0.14665	0.25168	0.37982
12.5	-	0.00527	0.01187	0.02089	0.03379	0.05794	0.07209	0.12624	0.19234	0.32553
14.0	-	0.00453	0.01013	0.01809	0.02691	0.05063	0.06102	0.10716	0.16348	0.29072
16.0	-	0.00384	0.00853	0.01340	0.02264	0.03872	0.05133	0.08159	0.13633	0.22357
18.0	-	0.00320	0.00758	0.01136	0.02005	0.03044	0.04385	0.06852	0.12189	0.18813
20.0	-	0.00276	0.00649	0.00949	0.01712	0.02542	0.04039	0.05722	0.10460	0.15546
22.4	-	0.00230	0.00550	0.00834	0.01578	0.02227	0.03414	0.04838	0.08840	0.13769
25.0	-	-	-	0.00710	-	0.01888	-	0.04442	-	0.11733
28.0	-	-	-	0.00598	-	0.01734	-	0.03728	-	0.09842
JL	-	0.006	0.010	0.010	0.045	0.045	0.045	0.045	0.100	0.100
	33	43	53	63	73	83	93	103	113	123
22.4	-	-	-	-	-	-	-	-	-	-
25.0	-	-	0.00645	-	0.01629	-	0.03910	-	0.10272	-
28.0	-	-	0.00536	-	0.01447	-	0.03237	-	0.08333	-
31.5	-	-	0.00474	0.00682	0.01209	0.01734	0.02874	0.04142	0.07242	0.11030
35.5	-	-	0.00418	0.00565	0.01070	0.01536	0.02550	0.03413	0.06284	0.08898
40.0	-	-	0.00343	0.00498	0.00888	0.01278	0.02129	0.03021	0.05440	0.07704
45.0	-	-	0.00301	0.00438	0.00782	0.01129	0.01874	0.02673	0.04799	0.06659
50.0	-	-	0.00228	0.00358	0.00570	0.00933	0.01359	0.02221	0.03603	0.05741
56.0	-	-	0.00194	0.00313	0.00487	0.00819	0.01162	0.01949	0.02835	0.05047
63.0	-	-	0.00163	0.00238	0.00413	0.00597	0.00982	0.01419	0.02386	0.03805
71.0	-	-	0.00123	0.00202	0.00324	0.00509	0.00738	0.01210	0.01900	0.02979
80.0	-	-	0.00102	0.00169	0.00278	0.00430	0.00624	0.01020	0.01595	0.02500
90.0	-	-	0.00088	0.00128	0.00229	0.00337	0.00520	0.00768	0.01453	0.01991
100	-	-	-	0.00106	-	0.00289	-	0.00648	-	0.01667
112	-	-	-	0.00091	-	0.00238	-	0.00539	-	0.01517
JL	-	-	0.006	0.006	0.010	0.010	0.020	0.020	0.045	0.045
	34	44	54	64	74	84	94	104	114	124
100	-	-	-	-	0.00328	-	0.00667	-	0.01753	-
112	-	-	-	-	0.00274	-	0.00552	-	0.01560	-
125	-	-	-	-	0.00243	0.00334	0.00486	0.00683	0.01310	0.01796
140	-	-	-	-	0.00202	0.00279	0.00428	0.00564	0.01164	0.01597
160	-	-	-	-	0.00176	0.00247	0.00348	0.00496	0.00970	0.01338
180	-	-	-	-	0.00153	0.00205	0.00300	0.00436	0.00848	0.01188
200	-	-	-	-	0.00124	0.00178	0.00230	0.00354	0.00595	0.00988
224	-	-	-	-	0.00097	0.00155	0.00195	0.00305	0.00508	0.00863
250	-	-	-	-	0.00081	0.00126	0.00163	0.00234	0.00428	0.00606
280	-	-	-	-	0.00065	0.00098	0.00134	0.00199	0.00354	0.00517
315	-	-	-	-	0.00060	0.00082	0.00112	0.00165	0.00304	0.00435
355	-	-	-	-	0.00050	0.00066	0.00097	0.00136	0.00252	0.00360
400	-	-	-	-	-	0.00060	-	0.00114	-	0.00309
450	-	-	-	-	-	0.00050	-	0.00098	-	0.00256

Redüktörün d₂ çıkış miline ilişkin kgm² cinsinden J2 Atalet Momenti, şu formülle hesaplanır: J₂=i_N²xJ₁ kgm² cinsinden J₁ Atalet Momentleri, redüktörün d₁ giriş miline bağlıdır ve fansız d₁ giriş milleri için geçerlidir. Fanlı d₁ millerinde ise JL ilave edilir. Flanş milleri redüktörlerin değerleri, talep üzerine temin edilir.

The mass moment of inertia J2 in kgm² refers to the output shaft d2 of a gear unit and is calculated with the following formula: J₂ = i_N² x J₁. The mass moment of inertia J₁ in kgm² refers to the input shaft d1 of a gear unit without fan. For shaft d1 with fan, JL has to be added. Values for gear units with flanged shaft on request.

Das auf Welle d₂ eines Getriebes bezogene Massenträgheitsmoment J₂ in kgm² wird nach folgender Formel errechnet: J₂ = i_N² x J₁. Die Massenträgheitsmomente J₁ in kgm² sind auf Welle d₁ der Getriebe bezogen und gelten für Welle d₁ ohne Lüfter. Bei Welle d₁ mit Lüfter ist JL zu addieren. Werte für Flanschwellengetriebe auf Anfrage.

TR KÜTLE ATALET MOMENTİ J1 (kgm²)

EN MASS MOMENTS OF INERTIA J1 IN kgm²
REFERRING TO SHAFT d1

DE MASSENTRÄGHEITSMOMENTE J1 IN kgm²
BEZOGEN AUF WELLE d1

i _N	Redüktör gövdeleri / Gear unit sizes / Getriebegrößen									
	131	141	151	161	171	181	191	201	211	221
1.25	-	-	-	-	-	-	-	-	-	-
1.4	-	-	-	-	-	-	-	-	-	-
1.6	3.74077	-	-	-	-	-	-	-	-	-
1.8	3.22057	-	-	-	-	-	-	-	-	-
2.0	2.90582	-	6.86903	-	11.68172	-	21.86950	-	-	-
2.24	2.61258	-	6.15225	-	10.37670	-	18.65867	-	-	-
2.5	2.33813	-	5.52442	-	9.40145	-	16.67579	-	-	-
2.8	2.08042	-	4.95982	-	8.44258	-	14.80399	-	-	-
3.15	1.67273	-	3.91162	-	6.72168	-	11.98945	-	-	-
3.55	1.47399	-	3.40747	-	5.86409	-	11.14244	-	-	-
4.0	1.28613	-	2.93210	-	5.05491	-	9.52270	-	-	-
4.5	0.96567	-	2.30308	-	4.00905	-	7.87489	-	-	-
5.0	0.89360	-	1.96108	-	3.55977	-	6.66044	-	-	-
5.6	0.75803	-	1.65759	-	3.01084	-	5.50473	-	-	-
JL	0.290	-	0.690	-	0.690	-	0.690	-	-	-
	132	142	152	162	172	182	192	202	212	222
6.3	1.10195	-	2.69450	-	5.30249	-	10.62628	-	14.12289	-
7.1	0.95997	-	2.36587	2.93445	4.38152	5.79425	9.32889	11.42554	12.30855	15.24965
8.0	0.83523	1.28897	2.07496	2.56276	3.85101	4.74843	8.17656	9.98029	10.71777	13.22687
9.0	0.72509	1.11239	1.81611	2.23558	3.37587	4.15070	7.14706	8.70419	9.31584	11.46160
10.0	0.62735	0.95870	1.58473	1.94622	2.94834	3.61890	6.27857	7.57118	8.14946	9.91374
11.2	0.55925	0.82433	1.37708	1.68919	2.56216	3.14368	5.52433	6.62132	7.14789	8.63265
12.5	0.42550	0.70636	1.14218	1.46006	2.04515	2.71748	4.44852	5.80139	5.67579	7.53848
14.0	0.36723	0.62499	0.97937	1.20991	1.76837	2.16566	3.81731	4.67000	4.86012	5.98802
16.0	0.31417	0.47348	0.82110	1.03247	1.51448	1.86457	3.23981	3.99197	4.12526	5.10635
18.0	0.28054	0.40553	0.68720	0.86324	1.21881	1.59010	2.59172	3.37526	3.27028	4.31621
20.0	0.23699	0.34428	0.56007	0.72007	1.10345	1.27695	2.24548	2.69238	2.81401	3.41219
22.4	-	0.30627	-	0.58429	-	1.15512	-	2.32662	-	2.92840
25.0	-	0.25717	-	-	-	-	-	-	-	-
28.0	-	-	-	-	-	-	-	-	-	-
JL	0.290	0.290	0.290	0.290	0.690	0.690	0.690	0.690	0.690	0.690
	133	143	153	163	173	183	193	203	213	223
22.4	0.28093	-	0.74161	-	0.81650	-	1.65788	-	3.73410	-
25.0	0.22706	-	0.60098	0.76346	0.65739	0.85893	1.33246	1.72711	3.03258	3.82925
28.0	0.18629	0.29678	0.52263	0.61732	0.56883	0.68913	1.15173	1.38384	2.63821	3.10389
31.5	0.16244	0.23899	0.45433	0.53601	0.49253	0.59483	0.99457	1.19361	2.29194	2.69673
35.5	0.14149	0.19520	0.36744	0.46523	0.39559	0.51371	0.85730	1.02850	1.98651	2.33968
40.0	0.12303	0.16971	0.31814	0.37536	0.34093	0.41097	0.73692	0.88457	1.71599	2.02518
45.0	0.10672	0.14739	0.28778	0.32445	0.30742	0.35319	0.65396	0.75863	1.47554	1.74703
50.0	0.07610	0.12778	0.21066	0.29316	0.22462	0.31786	0.46753	0.67202	1.20329	1.50020
56.0	0.06432	0.11049	0.17805	0.21496	0.18897	0.23297	0.39842	0.48071	1.01816	1.22342
63.0	0.05428	0.07906	0.14889	0.18145	0.15726	0.19556	0.33619	0.40895	0.86937	1.03395
71.0	0.04221	0.06666	0.12167	0.15152	0.13362	0.16237	0.28899	0.34446	0.69699	0.88189
80.0	0.03866	0.05611	0.10341	0.12385	0.11393	0.13785	0.24205	0.29606	0.55341	0.70676
90.0	0.03176	0.04362	0.08646	0.10516	0.09573	0.11733	0.19751	0.24759	0.50692	0.56061
100	-	0.03992	-	0.08784	-	0.09841	-	0.20171	-	0.51330
112	-	0.03274	-	-	-	-	-	-	-	-
JL	0.045	0.045	0.100	0.100	0.100	0.100	0.100	0.100	0.100	0.100
	134	144	154	164	174	184	194	204	214	224
100	0.03962	-	0.10814	-	0.11315	-	0.23894	-	0.60939	-
112	0.03254	-	0.08764	0.10910	0.09173	0.11518	0.19488	0.24222	0.52729	0.61425
125	0.02873	0.04034	0.07613	0.08829	0.07972	0.09324	0.16925	0.19732	0.45584	0.53127
140	0.02534	0.03309	0.06605	0.07672	0.06922	0.08096	0.14680	0.17125	0.36516	0.45909
160	0.02087	0.02919	0.05704	0.06652	0.05986	0.07022	0.12654	0.14842	0.31382	0.36751
180	0.01806	0.02572	0.04990	0.05742	0.05247	0.06066	0.10759	0.12785	0.28076	0.31570
200	0.01339	0.02115	0.03803	0.05022	0.03937	0.05313	0.08150	0.10862	0.21559	0.28235
224	0.01135	0.01829	0.02994	0.03828	0.03102	0.03991	0.06851	0.08231	0.18183	0.21687
250	0.00948	0.01358	0.02503	0.03013	0.02596	0.03140	0.05728	0.06915	0.15057	0.18284
280	0.00794	0.01150	0.02100	0.02517	0.02181	0.02626	0.04677	0.05779	0.12952	0.15135
315	0.00670	0.00960	0.01768	0.02111	0.01840	0.02206	0.04283	0.04716	0.10994	0.13017
355	0.00559	0.00803	0.01616	0.01777	0.01685	0.01859	0.03572	0.04318	0.09172	0.11046
400	-	0.00678	-	0.01625	-	0.01702	-	0.03599	-	0.09213
450	-	0.00565	-	-	-	-	-	-	-	-

Redüktörün d₂ çıkış miline ilişkin kgm² cinsinden J2 Atalet Momenti, şu formülle hesaplanır: J₂=i_N²xJ₁ kgm² cinsinden J₁ Atalet Momentleri, redüktörün d₁ giriş miline bağlıdır ve fansız d₁ giriş milleri için geçerlidir. Fanlı d₁ millerinde ise JL ilave edilir. Flanş milleri redüktörlerin değerleri, talep üzerine temin edilir.

The mass moment of inertia J2 in kgm² refers to the output shaft d2 of a gear unit and is calculated with the following formula: J2 = iN² x J1. The mass moment of inertia J1 in kgm² refers to the input shaft d1 of a gear unit without fan. For shaft d1 with fan, JL has to be added. Values for gear units with flanged shaft on request.

Das auf Welle d2 eines Getriebes bezogene Massenträgheitsmoment J2 in kgm² wird nach folgender Formel errechnet: J2 = iN² x J1. Die Massenträgheitsmomente J1 in kgm² sind auf Welle d1 der Getriebe bezogen und gelten für Welle d1 ohne Lüfter. Bei Welle d1 mit Lüfter ist JL zu addieren. Werte für Flanschwellengetriebe auf Anfrage.

TR KÜTLE ATALET MOMENTİ J1 (kgm²)

EN MASS MOMENTS OF INERTIA J1 IN kgm²
REFERRING TO SHAFT d1

DE MASSENTRÄGHEITSMOMENTE J1 IN kgm²
BEZOGEN AUF WELLE d1

i _N	Redüktör gövdeleri / Gear unit sizes / Getriebegrößen								
	42	52	62	72	82	92	102	112	122
5.0	0.03211	0.07501	–	0.20154	–	0.44627	–	1.29058	–
5.6	0.03024	0.06915	–	0.17137	–	0.37934	–	1.08250	–
6.3	0.02673	0.05791	0.08406	0.13819	0.23057	0.30248	0.50622	0.85265	1.48203
7.1	0.02249	0.04955	0.07668	0.11905	0.19554	0.25734	0.42923	0.73360	1.23242
8.0	0.01814	0.03799	0.06347	0.08858	0.15603	0.18973	0.33932	0.53110	0.96847
9.0	0.01486	0.03115	0.05410	0.07952	0.13365	0.17287	0.28749	0.48051	0.82632
10.0	0.01037	0.02538	0.04185	0.06883	0.09965	0.14614	0.21259	0.41113	0.60295
11.2	0.00931	0.02176	0.03406	0.05956	0.08888	0.12482	0.19220	0.35269	0.54127
12.5	–	–	0.02760	–	0.07596	–	0.16085	–	0.45737
14.0	–	–	0.02366	–	0.06566	–	0.13741	–	0.39227
JL	0.020	0.045	0.045	0.100	0.100	0.100	0.100	0.290	0.290
	43	53	63	73	83	93	103	113	123
12.5	0.00756	0.01615	–	0.04549	–	0.10285	–	0.27616	–
14.0	0.00734	0.01575	–	0.04455	–	0.09999	–	0.26878	–
16.0	0.00623	0.01371	0.01750	0.03768	0.04966	0.08727	0.11205	0.23571	0.30357
18.0	0.00610	0.01346	0.01695	0.03713	0.04831	0.08550	0.10750	0.23105	0.29302
20.0	0.00569	0.01248	0.01458	0.03464	0.04011	0.07999	0.09297	0.21547	0.25301
22.4	0.00527	0.01157	0.01422	0.03229	0.03933	0.07329	0.09015	0.18297	0.24635
25.0	0.00456	0.01073	0.01308	0.02828	0.03637	0.06097	0.08364	0.14675	0.22734
28.0	0.00394	0.00881	0.01206	0.02376	0.03369	0.05206	0.07633	0.12605	0.19285
31.5	0.00335	0.00730	0.01109	0.01922	0.02934	0.04011	0.06322	0.09389	0.15405
35.5	0.00271	0.00586	0.00911	0.01568	0.02463	0.03275	0.05390	0.08401	0.13203
40.0	0.00190	0.00416	0.00755	0.01100	0.01996	0.02660	0.04168	0.07225	0.09842
45.0	0.00177	0.00393	0.00605	0.00984	0.01624	0.02280	0.03393	0.06249	0.08784
50.0	0.00129	0.00301	0.00431	0.00812	0.01143	0.01784	0.02750	0.04683	0.07516
56.0	0.00105	0.00248	0.00405	0.00682	0.01020	0.01462	0.02357	0.03850	0.06498
63.0	0.00087	0.00207	0.00310	0.00589	0.00840	0.01242	0.01844	0.03265	0.04876
71.0	0.00067	0.00157	0.00256	0.00467	0.00705	0.00997	0.01509	0.02622	0.04002
80.0	–	–	0.00213	–	0.00607	–	0.01280	–	0.03390
90.0	–	–	0.00162	–	0.00481	–	0.01027	–	0.02719
JL	0.006	0.010	0.010	0.020	0.020	0.045	0.045	0.100	0.100
	44	54	64	74	84	94	104	114	124
80.0	–	0.00240	–	0.00589	–	0.01293	–	0.03573	–
90.0	–	0.00227	–	0.00543	–	0.01193	–	0.03317	–
100	–	0.00200	0.00244	0.00468	0.00600	0.01100	0.01317	0.02895	0.03644
112	–	0.00176	0.00230	0.00404	0.00551	0.00903	0.01212	0.02431	0.03375
125	–	0.00145	0.00202	0.00344	0.00474	0.00749	0.01114	0.01969	0.02939
140	–	0.00117	0.00178	0.00278	0.00409	0.00600	0.00915	0.01603	0.02467
160	–	0.00091	0.00147	0.00195	0.00348	0.00427	0.00759	0.01127	0.01999
180	–	0.00085	0.00118	0.00181	0.00281	0.00402	0.00608	0.01007	0.01626
200	–	0.00058	0.00092	0.00132	0.00198	0.00308	0.00433	0.00830	0.01145
224	–	0.00047	0.00086	0.00108	0.00183	0.00254	0.00407	0.00696	0.01021
250	–	0.00043	0.00058	0.00090	0.00134	0.00211	0.00312	0.00600	0.00841
280	–	0.00033	0.00047	0.00069	0.00109	0.00160	0.00257	0.00476	0.00705
315	–	0.00028	0.00043	0.00058	0.00091	0.00136	0.00214	0.00405	0.00608
355	–	–	0.00034	–	0.00070	–	0.00162	–	0.00482
400	–	–	0.00028	–	0.00059	–	0.00138	–	0.00409

Redüktörün d₂ çıkış miline ilişkin kgm² cinsinden J2 Atalet Momenti, şu formülle hesaplanır: J₂=i_N²×J₁ kgm² cinsinden J₁ Atalet Momentleri, redüktörün d₁ giriş miline bağlıdır ve fansız d₁ giriş milleri için geçerlidir.
Fanlı d₁ millerinde ise JL ilave edilir.
Fanlı millili redüktörlerin değerleri, talep üzerine temin edilir.

The mass moment of inertia J2 in kgm² refers to the output shaft d₂ of a gear unit and is calculated with the following formula: J₂ = i_N² × J₁. The mass moment of inertia J₁ in kgm² refers to the input shaft d₁ of a gear unit without fan.
For shaft d₁ with fan, JL has to be added.
Values for gear units with flanged shaft on request.

Das auf Welle d₂ eines Getriebes bezogene Massenträgheitsmoment J₂ in kgm² wird nach folgender Formel errechnet: J₂ = i_N² × J₁. Die Massenträgheitsmomente J₁ in kgm² sind auf Welle d₁ der Getriebe bezogen und gelten für Welle d₁ ohne Lüfter.
Bei Welle d₁ mit Lüfter ist JL zu addieren.
Werte für Flanschwellengetriebe auf Anfrage.

TR KÜTLE ATALET MOMENTİ J1 (kgm²)

EN MASS MOMENTS OF INERTIA J1 IN kgm²
REFERING TO SHAFT d1

DE MASSENTRÄGHEITSMOMENTE J1 IN kgm²
BEZOGEN AUF WELLE d1

i _N	Redüktör gövdeleri / Gear unit sizes / Getriebegrößen									
	132	142	152	162	172	182	192	202	212	222
5.0	2.79496	–	6.25795	–	–	–	–	–	–	–
5.6	2.36141	–	5.40648	6.66677	10.37011	–	–	–	–	–
6.3	1.86785	3.10156	4.49760	5.72660	8.58657	–	–	–	–	–
7.1	1.63448	2.60149	3.77001	4.74810	7.14219	9.06446	–	–	–	–
8.0	1.18384	2.05333	2.78214	3.96800	5.01824	7.51989	–	–	–	–
9.0	1.06973	1.78297	2.53133	2.93557	4.52494	5.31094	–	–	–	–
10.0	0.92751	1.29891	2.16711	2.66107	3.85677	4.77245	–	–	–	–
11.2	0.80120	1.16704	1.81377	2.26584	3.32075	4.04511	–	–	–	–
12.5	–	1.00155	–	1.89831	–	3.48202	–	–	–	–
14.0	–	0.86460	–	–	–	–	–	–	–	–
JL	0.690	0.690	0.690	0.690	0.690	0.690	–	–	–	–
	133	143	153	163	173	183	193	203	213	223
12.5	0.61844	–	1.69718	–	3.48560	–	7.88960	–	8.38770	–
14.0	0.60537	–	1.65740	1.76004	3.44624	3.60423	7.73050	8.06590	8.21860	8.60520
16.0	0.51600	0.66451	1.48103	1.70973	3.06690	3.54418	6.99890	7.84000	7.44080	8.36430
18.0	0.50838	0.64618	1.45557	1.52126	3.04252	3.14038	6.83980	6.95600	7.27170	7.41420
20.0	0.47566	0.54284	1.37309	1.48906	2.88266	3.10318	6.37936	6.83990	6.79596	7.29720
22.4	0.40380	0.53216	1.14711	1.39966	2.43009	2.93035	5.50155	6.46478	5.82775	6.91637
25.0	0.32054	0.49435	0.90256	1.16792	1.92090	2.46743	4.57199	5.56843	4.82726	5.92204
28.0	0.27212	0.41936	0.77356	0.91864	1.67696	1.94976	3.82881	4.62433	4.03056	4.90105
31.5	0.20094	0.33203	0.56206	0.78643	1.21675	1.70005	2.82771	3.87017	2.98405	4.08888
35.5	0.18235	0.28152	0.50670	0.57204	1.09757	1.23465	2.56986	2.85976	2.70207	3.02924
40.0	0.15335	0.20806	0.43106	0.51513	0.94869	1.11270	2.19643	2.59697	2.29704	2.74029
45.0	0.13099	0.18837	0.36975	0.43748	0.81933	0.96021	1.83887	2.21706	1.92502	2.32612
50.0	0.10268	0.15794	0.27673	0.37524	0.57171	0.82919	1.40288	1.85654	1.46929	1.94992
56.0	0.08549	0.13492	0.22863	0.28096	0.46952	0.57931	1.14615	1.41650	1.19871	1.48849
63.0	0.07262	0.10571	0.19582	0.23198	0.40563	0.47553	1.04477	1.15693	1.08801	1.21390
71.0	0.05866	0.08789	0.15881	0.19858	0.33347	0.41058	0.84654	1.05364	0.87983	1.10050
80.0	–	0.07459	–	0.16093	–	0.33728	–	0.85337	–	0.88945
90.0	–	0.06017	–	–	–	–	–	–	–	–
JL	0.290	0.290	0.290	0.290	0.690	0.690	0.690	0.690	0.690	0.690
	134	144	154	164	174	184	194	204	214	224
80.0	0.08226	–	0.22213	–	0.22783	–	0.49622	–	1.41079	–
90.0	0.07518	–	0.18851	0.22377	0.19326	0.23101	0.42091	0.50136	1.17663	1.41869
100	0.06237	0.08339	0.15085	0.18988	0.15435	0.19590	0.33318	0.42519	0.92537	1.18281
112	0.05320	0.07613	0.12941	0.15185	0.13227	0.15630	0.28247	0.33633	0.79182	0.93015
125	0.04108	0.06307	0.09644	0.13023	0.09861	0.13387	0.20878	0.28505	0.57621	0.79564
140	0.03348	0.05377	0.08616	0.09706	0.08799	0.09982	0.18898	0.21073	0.51866	0.57917
160	0.02716	0.04157	0.07389	0.08669	0.07528	0.08902	0.15840	0.19063	0.44016	0.52117
180	0.02328	0.03385	0.06389	0.07429	0.06509	0.07606	0.13531	0.15966	0.37754	0.44207
200	0.01821	0.02744	0.04791	0.06423	0.04883	0.06575	0.10601	0.13639	0.28273	0.37918
224	0.01491	0.02352	0.03935	0.04818	0.04008	0.04935	0.08813	0.10684	0.23338	0.28399
250	0.01266	0.01840	0.03335	0.03956	0.03395	0.04049	0.07479	0.08879	0.19973	0.23438
280	0.01016	0.01506	0.02676	0.03353	0.02723	0.03429	0.06032	0.07533	0.16181	0.20055
315	0.00812	0.01278	0.02169	0.02690	0.02207	0.02748	0.04934	0.06074	0.12885	0.16245
355	–	0.01025	–	0.02180	–	0.02228	–	0.04968	–	0.12937
400	–	0.00820	–	–	–	–	–	–	–	–

Redüktörün d₂ çıkış miline ilişkin kgm² cinsinden J2 Atalet Momenti, şu formülle hesaplanır: J₂=i_N²×J₁ kgm² cinsinden J₁ Atalet Momentleri, redüktörün d₁ giriş miline bağlıdır ve fansız d₁ giriş milleri için geçerlidir. Fanlı d₁ millerinde ise JL ilave edilir. Fanlı miller için redüktörlerin değerleri, talep üzerine temin edilir.

The mass moment of inertia J2 in kgm² refers to the output shaft d2 of a gear unit and is calculated with the following formula: J₂ = i_N² × J₁. The mass moment of inertia J₁ in kgm² refers to the input shaft d1 of a gear unit without fan. For shaft d1 with fan, JL has to be added. Values for gear units with flanged shaft on request.

Das auf Welle d₂ eines Getriebes bezogene Massenträgheitsmoment J₂ in kgm² wird nach folgender Formel errechnet: J₂ = i_N² × J₁. Die Massenträgheitsmomente J₁ in kgm² sind auf Welle d₁ der Getriebe bezogen und gelten für Welle d₁ ohne Lüfter. Bei Welle d₁ mit Lüfter ist JL zu addieren. Werte für Flanschwellengetriebe auf Anfrage.

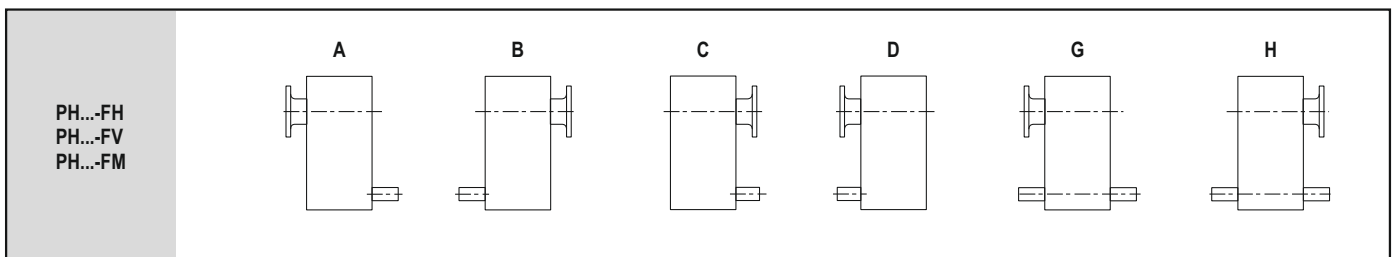
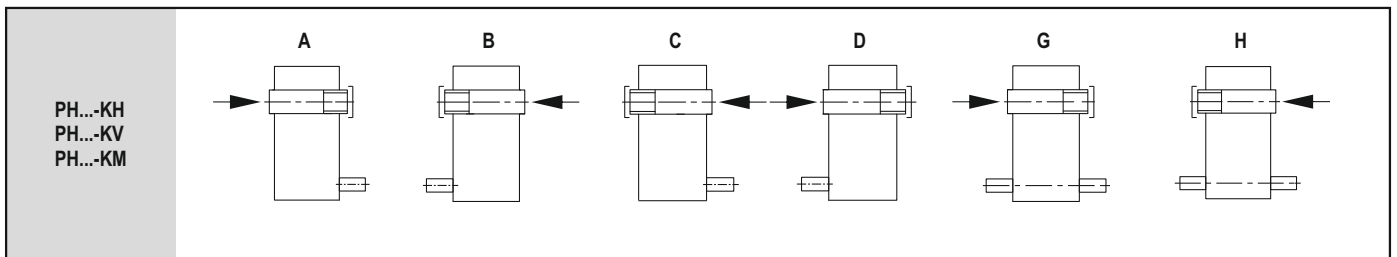
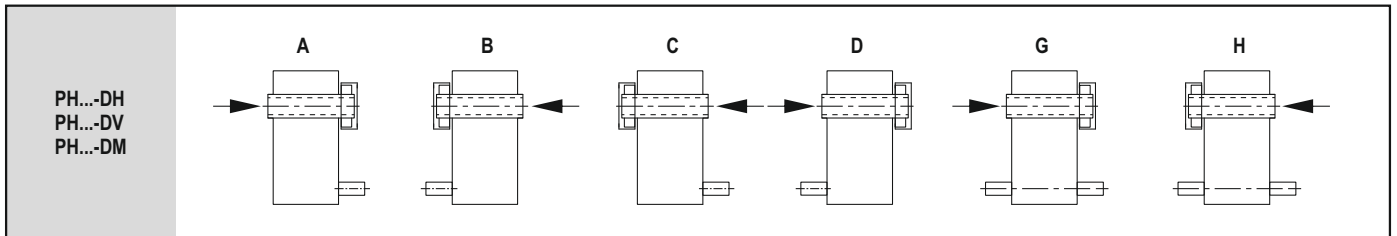
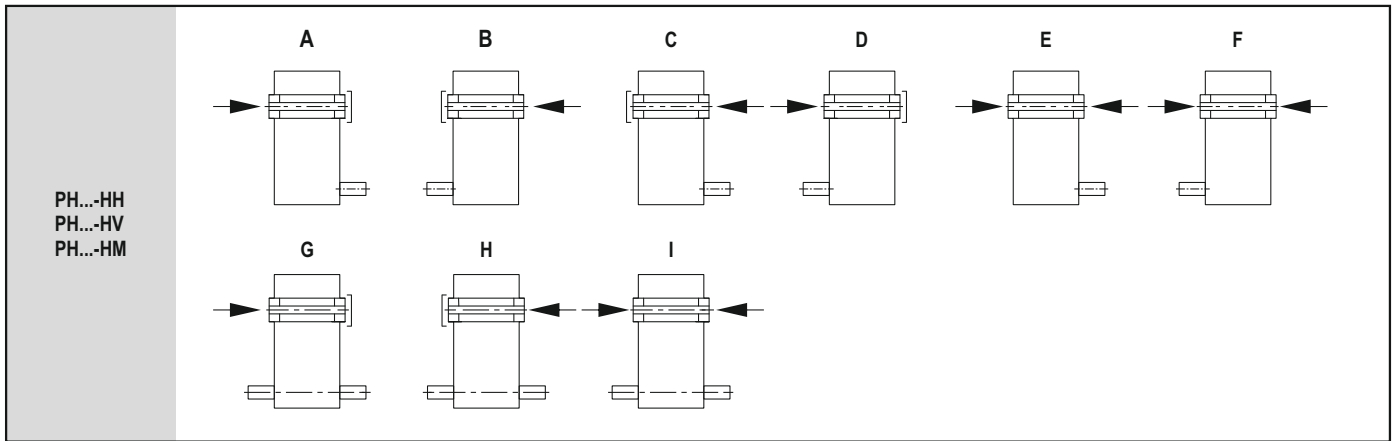
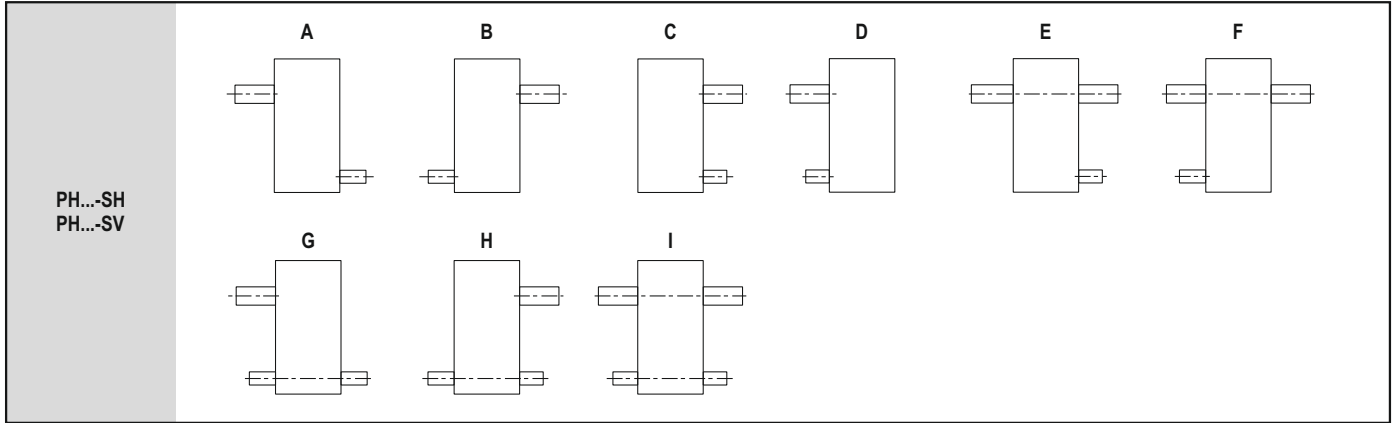

→ Hareket verilecek makina millerini takma yönü, ok işareti ile gösterilmiştir.
The arrow indicates the direction of insertion of the driven machine shaft
Der Pfeil kennzeichnet die Einführrichtung der Arbeitsmaschinenwelle

TR

MONTAJLAR

EN

ASSEMBLIES

DE

AUSFÜHRUNGSFORMEN

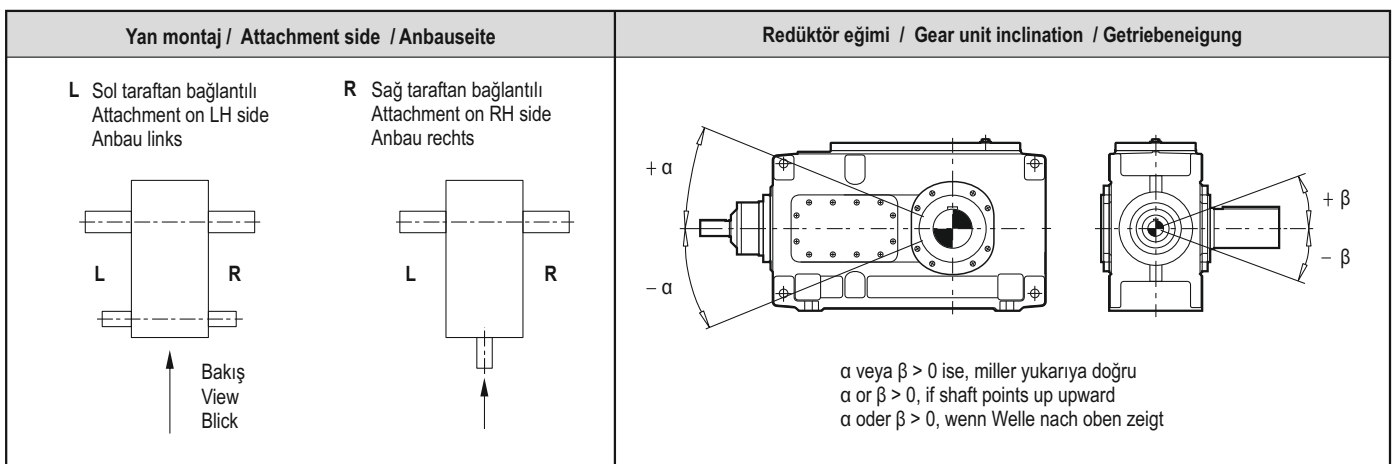
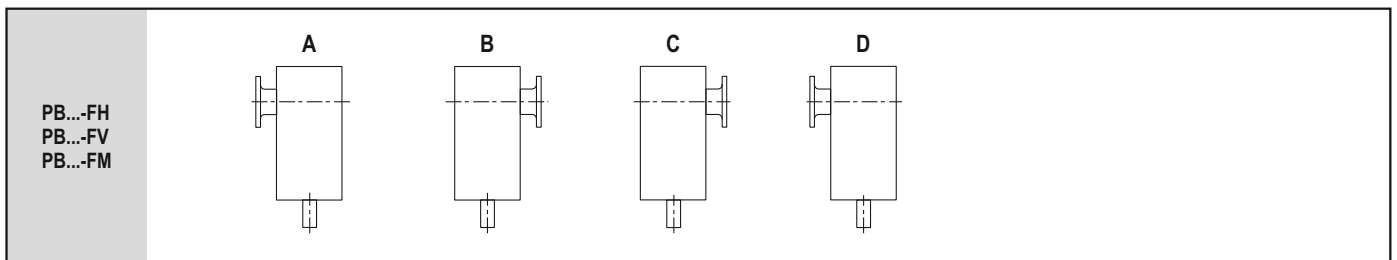
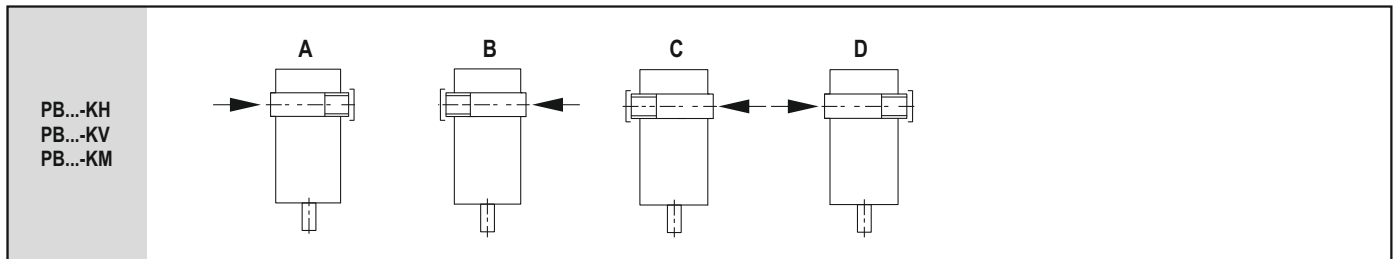
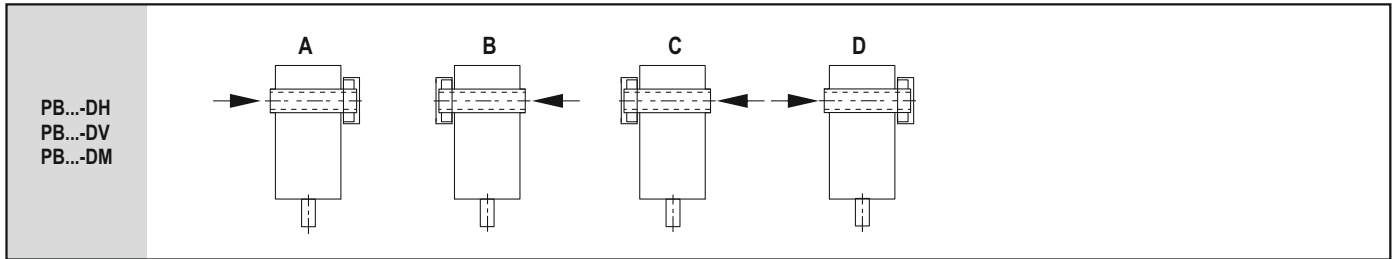
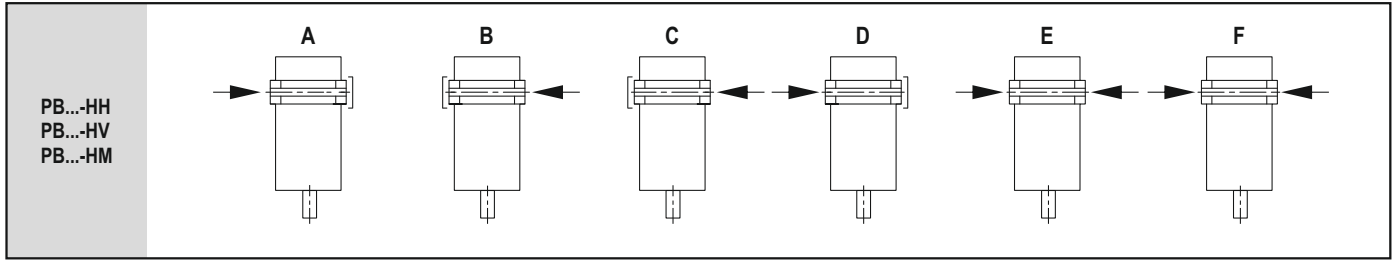
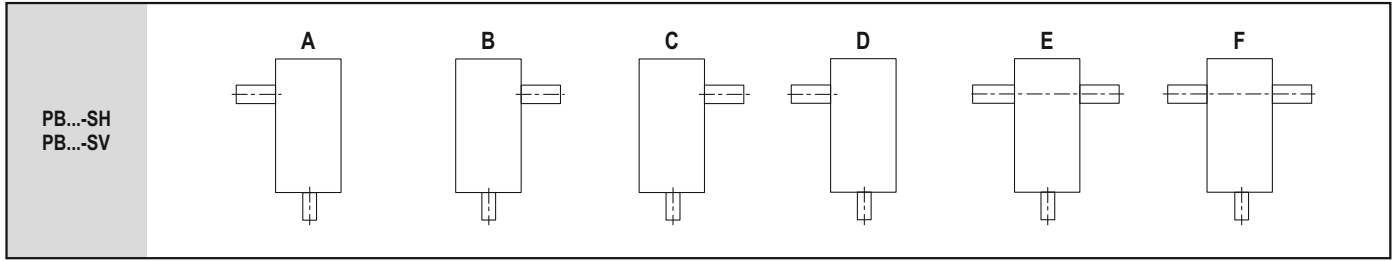



A series of horizontal dotted lines spanning the width of the page, intended for writing or drawing.

Ölçü Tabloları

Dimension Tables

Größe Tabellen

PH...

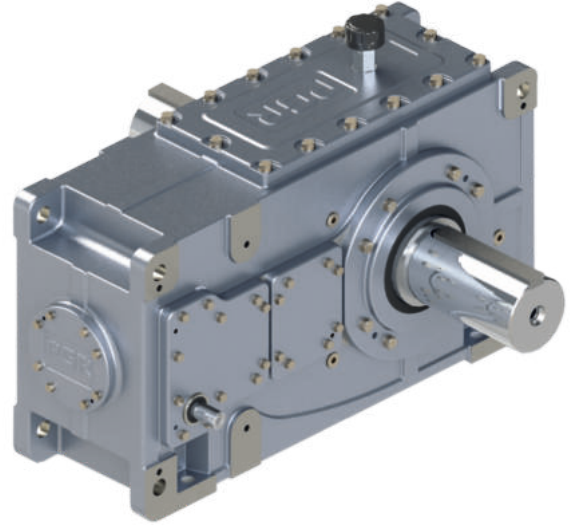

TEK KADEME / SINGLE STAGE / EINSTUFIG
İKİ KADEME / DOUBLE STAGE / ZWEISTUFIG
ÜÇ KADEME / THREE STAGE / DREISTUFIG
DÖRT KADEME / FOUR STAGE / VIERSTUFIG

PH SERİSİ / YATAY
PH SERIES / HORIZONTAL
PH SERIE / HORIZONTAL

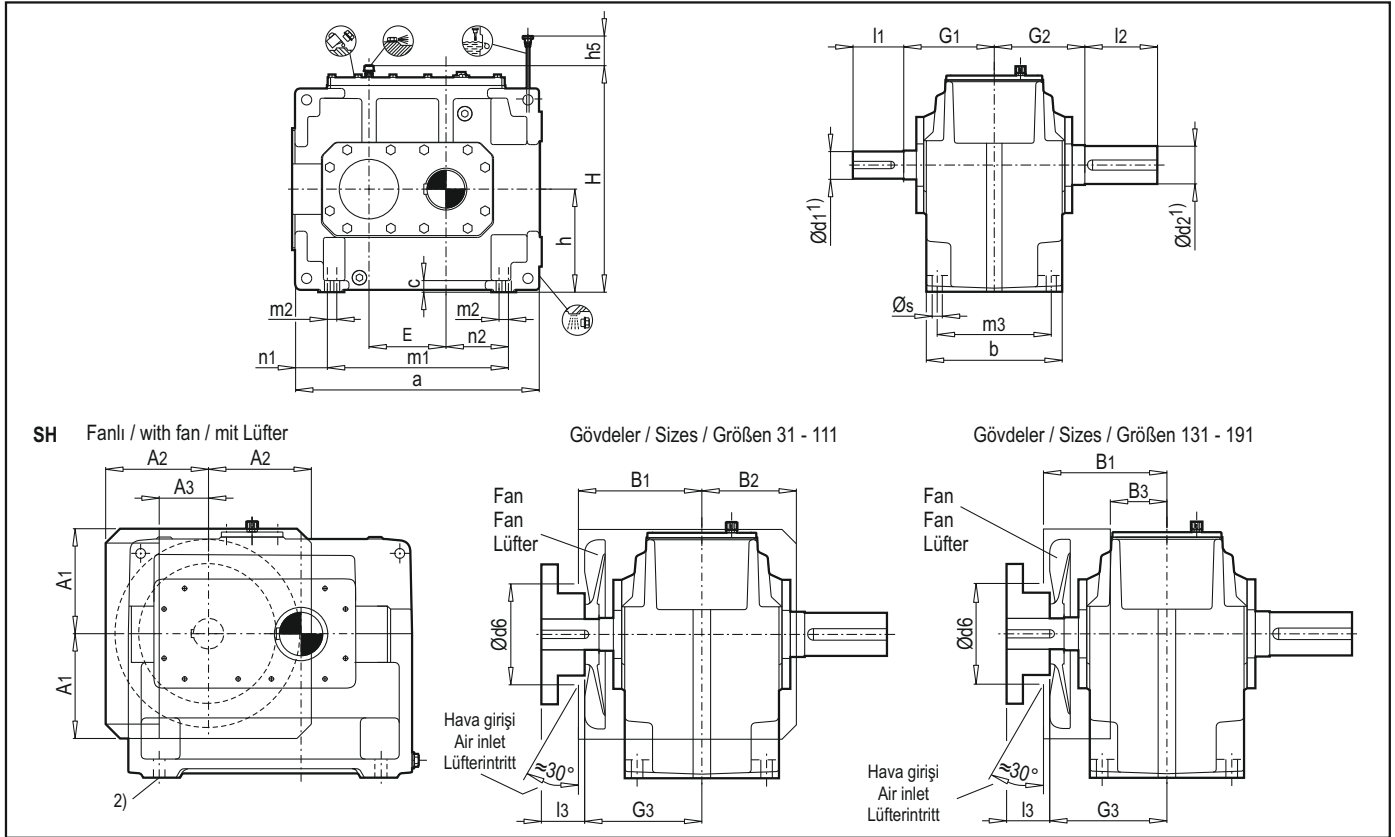

Gövde Size Größe	Giriş / Input / Antrieb															Fan / Fan / Lüfter								
	İN = 1.25 - 2.8			İN = 1.6 - 2.8			İN = 2 - 2.8			İN = 3.15 - 4			İN = 4.5 - 5.6			G1	G3	A1	A2	A3	B1	B2	B3	Ød6
	Ød1	l1	l3	Ød1	l1	l3	Ød1	l1	l3	Ød1	l1	l3	Ød1	l1	l3									
31	60	125	105	-	-	-	-	-	-	45	100	80	32	80	60	170	190	152	147	85	210	132	-	130
51	85	160	130	-	-	-	-	-	-	60	135	105	50	110	80	210	240	227	217	120	260	187	-	190
71	100	200	165	-	-	-	-	-	-	75	140	105	60	140	105	250	285	257	252	125	305	232	-	245
91	110	200	165	-	-	-	-	-	-	90	165	130	75	140	105	280	315	302	267	145	335	267	-	280
111	-	-	-	130	240	205	-	-	-	110	205	170	90	170	135	325	360	362	332	195	380	322	-	350
131	-	-	-	150	245	200	-	-	-	130	245	200	100	210	165	365	410	417	352	-	435	-	150	350
151	-	-	-	-	-	-	180	290	240	150	250	200	125	250	200	360	410	502	432	-	435	-	120	450
171	-	-	-	-	-	-	200	330	280	170	290	240	140	250	200	400	450	552	432	-	475	-	150	445
191	-	-	-	-	-	-	220	340	290	190	340	290	160	300	250	440	490	632	477	-	515	-	190	445

Gövde Size Größe	Redüktörler / Gear units / Zahnradgetriebe													
	a	b	c	E	H	h (-1)	h5	m1	m2	m3	n1	n2	Øs	
31	424	200	30	130	380	200	85	310	-	160	57	110	19	
51	584	285	37	185	530	290	100	440	-	240	72	160	24	
71	694	375	47	225	630	350	75	540	-	315	77	195	28	
91	809	425	52	265	740	420	50	625	-	350	92	225	35	
111	964	515	62	320	880	500	40	770	-	440	97	280	35	
131	1104	580	72	370	1025	580	40	870	-	490	117	315	42	
151	1299	545	82	442	1120	600	10	1025	-	450	137	370	48	
171	1414	615	82	490	1240	670	-	1170	130	530	122	425	42	
191	1594	690	92	555	1400	760	-	1290	150	590	152	465	48	

Ölçüler mm'dir.

1) Şaftlar

m6<=Ø100; n6>Ø100

Kama kanalı DIN 6885/1,

Kama kanalı genişliği ISO JS9 a göre

Kama DIN 6885/1 form B

Ayrıntılar için sayfa 127-136'ya bakılabilir.

2) Bağlantı civatalarını takmadan önce havalandırma kapağını çıkartınız.

*) Yaklaşık değerlerdir. Kesin verilere siparişte gönderilen dökümanlardan ulaşılabilir.

Şaft keçeleri için sayfa 159-161 bakınız.

**) Redüktörler yağsızdır.

Dimensions in mm

1) Shafts:

m6<=Ø100; n6>Ø100

Keyway acc.to DIN 6885/1,

Hub keyway width acc.to ISO JS9

Parallel key acc.to DIN 6885/1 form B

For details, see pages 127-136.

2) Remove air guide cover before fitting the foundation bolts.

*) Approximate values; exact data acc.to order related documentation.

For shaft seals, see pages 159-161

**) Without oil filling

Abmessungen in mm

1) Wellen:

m6<=Ø100; n6>Ø100

Passfedernut nach DIN 6885/1

Nabennutbreite nach ISO JS9

Passfeder nach DIN 6885/1 Form B

Einzelheiten siehe Seiten 127-136

2) Vor dem Befestigen der fußschrauben ist die Luftleithaube zu entfernen.

*) Richtwerte; genaue Angaben nach auftragsbezogener Dokumentation.

Wellenabdichtungen siehe seiten 159-161

**) ohne Ölfüllung

TR

TEK KADEMELİ - YATAY

EN

SINGLE STAGE - HORIZONTAL

DE

EINSTUFIG - HORIZONTAL

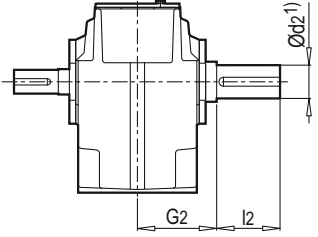
	<p>PH31-SH ... PH191-SH Mil Çıkışlı Solid shaft Vollwelle</p>		Ød2	l2	G2
		31	60	125	170
		51	85	160	210
		71	105	200	250
		91	125	210	270
		111	150	240	320
		131	180	310	360
		151	220	350	360
		171	240	400	400
		191	270	450	440

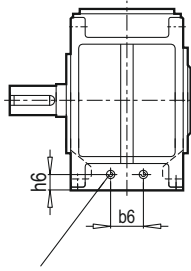
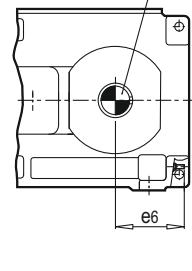
Gövde Size Größe	Yağ miktarı / Oil quantity / Ölmenge (l)*		Ağırlık Weight Gewicht (kg) *) **	Soğutma serpantini / Cooling coil / Kühlschlange		Gövde Size Größe	b6	e6	h6	l/min x)
	Çıkış keçesi Shaft seal Wellen- dichtring	Labirent keçe Labyrinth seal Labyrinthdichtung		Çıkış / Output / Abtrieb						
31	7	5.2	130			31	48	205	74	4
51	22	18	305			51	88	270	90	4
71	42	34	550			71	124	310	135	4
91	68	57	865			91	116	365	110	8
111	120	100	1520			111	146	425	130	8
131	175	155	2400			131	152	480	150	8
151	190	156	3210			151	172	560	130	8
171	270	225	4260			171	202	600	145	8
191	390	330	5850			191	Talep üzerine On request Auf Anfrage			

Soğutma serpantini su bağlantısı G1/2"
Water connection for cooling coil G1/2"
Wasseranschluß für Kühlschlange G1/2"

Soğutma sistemi deniz suyu ve acı su için uygundur.
Cooling coil suitable for fresh, sea and brackish water
Kühlschlange geeignet für Süß- See- und Brackwasser

x) Gereklı soğutma suyu miktarı; basıncı 8 bar
Cooling water quantity required, max. cooling water pressure: 8 bar
Erforderliche Kühlwassermenge, max. kühlwasserdruck: 8 bar

TR

İKİ KADEMELİ - YATAY

EN

TWO STAGE - HORIZONTAL

DE

ZWEISTUFIG - HORIZONTAL

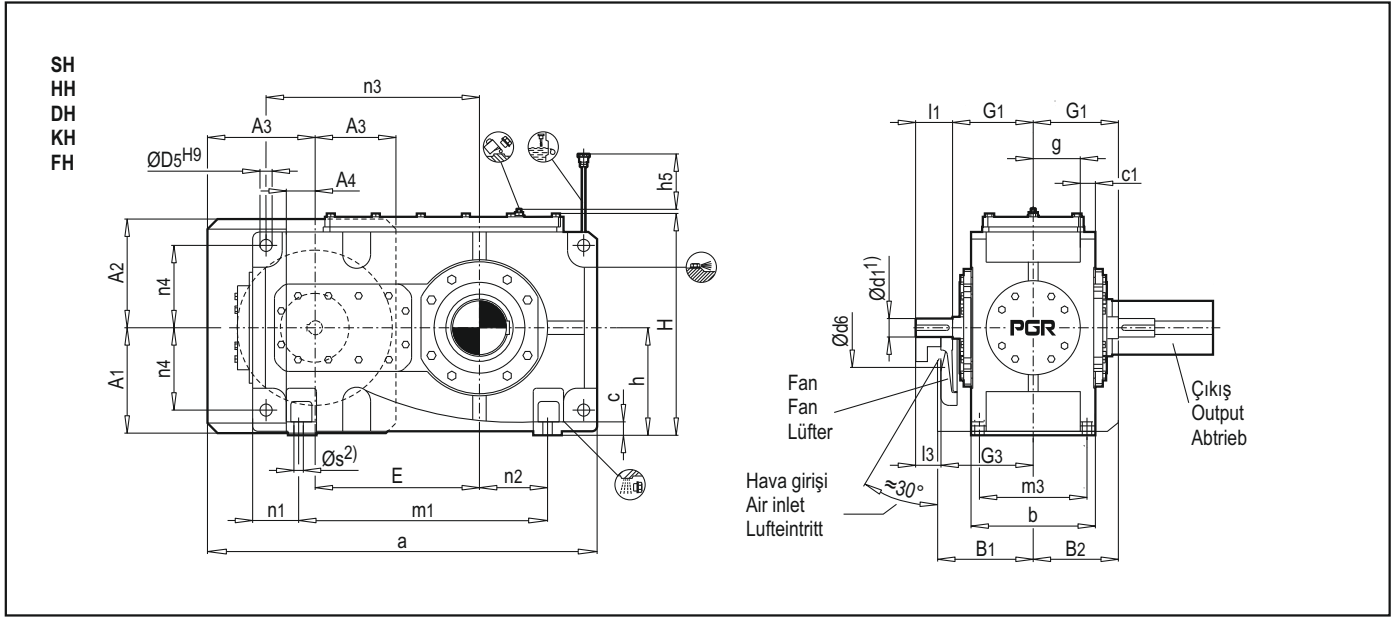

Gövde Size Größe	Giriş / Input / Antrieb												Fan / Fan / Lüfter								
	İN = 6.3 - 11.2			İN = 12.5 - 22.4			İN = 8 - 14			İN = 16 - 28			G1	G3	A1	A2	A3	A4	B1	B2	Ød6
	Ød1	l1	l3	Ød1	l1	l3	Ød1	l1	l3	Ød1	l1	l3									
42	45	100	80	32	80	60	-	-	-	-	-	-	170	190	197	227	152	32	207	160	136
52	50	100	80	38	80	60	-	-	-	-	-	-	195	215	227	262	177	57	232	180	150
62	-	-	-	-	-	-	50	100	80	38	80	60	195	215	227	262	177	57	232	180	150
72	60	135	105	50	110	80	-	-	-	-	-	-	210	240	274	307	212	72	257	212	200
82	-	-	-	-	-	-	60	135	105	50	110	80	210	240	274	307	212	72	257	212	200
92	75	140	110	60	140	110	-	-	-	-	-	-	240	270	314	357	242	102	287	247	200
102	-	-	-	-	-	-	75	140	110	60	140	110	240	270	314	357	242	102	287	247	200
112	90	165	130	70	140	105	-	-	-	-	-	-	275	310	374	422	287	137	327	287	210
122	-	-	-	-	-	-	90	165	130	70	140	105	275	310	374	422	287	137	327	287	210

Gövde Size Größe	Redüktörler / Gear Units / Zahnradgetriebe																Kilit Backstop Rücklaufsperre		
	a	b	c	c1	ØD5	E	g	H	h(-1)	h5	m1	m3	n1	n2	n3	n4	Øs	84	G8
42	569	215	30	31	24	270	78	420	200	110	355	180	107	85	345	150	19		209
52	644	255	30	31	24	315	98	487	230	150	430	220	107	100	405	180	19		255
62	724	255	30	31	24	350	98	487	230	150	510	220	107	145	440	180	19		255
72	789	300	37	37	28	385	115	577	280	190	545	260	122	130	500	215	24		282
82	894	300	37	37	28	430	115	587	280	190	650	260	122	190	545	215	24		282
92	929	370	42	47	36	450	141	667	320	205	635	320	147	155	585	245	28		333
102	1029	370	42	47	36	500	141	667	320	215	735	320	147	205	635	245	28		333
112	1109	430	52	56	40	545	162	787	380	250	775	370	167	180	710	300	35		394
122	1264	430	52	56	40	615	162	795	380	250	930	370	167	265	780	300	35		394

+) Max ölçülerdir. Ayrıntılara siparişte gönderilen dokümanlardan ulaşılabilir.
Ölçüler mm'dir.

+) Max. dimensions; details acc. to order related documentation.
Dimensions in mm

+) max. Abmessungen; Einzelheiten nach auftragsbezogener Dokumentation.
Abmessungen in mm

1) Şaftlar

m6<=Ø100; n6>Ø100
Kama kanalı DIN 6885/1,
Kama kanalı genişliği ISO JS9 a göre
Kama DIN 6885/1 form B
Ayrıntılar için sayfa 127-136'ya bakılabilir.

2) Bağlantı civatalarını takmadan önce havalandırma kapağını çıkartınız.

*) Yaklaşık değerlerdir. Kesin verilere siparişte gönderilen dokümanlardan ulaşılabilir.
Şaft keçeleri için sayfa 159-161 bakınız.

** Redüktörler yağsızdır.

1) Shafts:

m6<=Ø100; n6>Ø100
Keyway acc.to DIN 6885/1,
Hub keyway width acc.to ISO JS9
Parallel key acc.to DIN 6885/1 form B
For details, see pages 127-136.

2) Remove air guide cover before fitting the foundation bolts.

*) Approximate values; exact data acc.to order related documentation.

For shaft seals, see pages 159-161.

** Without oil filling

1) Wellen:

m6<=Ø100; n6>Ø100
Passfedernut nach DIN 6885/1
Nabennutbreite nach ISO JS9
Passfeder nach DIN 6885/1 Form B
Einzelheiten siehe Seiten 127-136.

2) Vor dem Befestigen der fußschrauben ist die Luftleithaube zu entfernen.

*) Richtwerte; genaue Angaben nach auftragsbezogener Dokumentation.
Wellenabdichtungen siehe seiten 159-161.

** ohne Ölfüllung

TR

İKİ KADEMELİ - YATAY

EN

TWO STAGE - HORIZONTAL

DE

ZWEISTUFIG - HORIZONTAL

	<p>PH42-SH ... PH122-SH Mil Çıkışlı Solid shaft Vollwelle</p>		Ød2	l2	G2
		42	80	170	140
		52	100	210	165
		62	110	210	165
		72	120	210	195
		82	130	250	195
		92	140	250	235
		102	160	300	235
112	170	300	270		
122	180	300	270		

	<p>PH42-HH ... PH122-HH Delik milli Hollow shaft Hohlwelle</p>		ØD2	G4
		42	80	140
		52	95	165
		62	105	165
		72	115	195
		82	125	195
		92	135	235
		102	150	235
112	165	270		
122	180	270		

	<p>PH42-DH ... PH122-DH Konik Sıktırma Hollow shaft for shrink disk Hohlwelle für schrumpfscheibe</p>		ØD2	ØD3	G4	G5
		42	85	85	140	205
		52	100	100	165	240
		62	110	110	165	240
		72	120	120	195	280
		82	130	130	195	285
		92	140	145	235	330
		102	150	155	235	350
112	165	170	270	400		
122	180	185	270	405		

	<p>PH42-KH ... PH122-KH Spline DIN 5480 Hollow shaft with involute splines acc. to DIN 5480 Hohlwelle mit Zahnabprofil nach DIN 5480</p>		N / DIN 5480	ØD2	ØD3	G4
		42	-	-	-	
		52	N 95x3x30x30x9H	89	100	165
		62	N 95x3x30x30x9H	89	110	165
		72	N 120x3x30x38x9H	114	120	195
		82	N 120x3x30x38x9H	114	130	195
		92	N 140x3x30x45x9H	134	145	235
		102	N 140x3x30x45x9H	134	155	235
112	N 170x5x30x32x9H	160	170	270		
122	N 170x5x30x32x9H	160	185	270		

	<p>PH42-FH ... PH122-FH Flanşlı şaft Flanged shaft Flanschswelle</p>		c	Ød2	ØD3	Øk2	n x Øs	t	G7
		42	-	-	-	-	-	-	-
		52	25	300	150	260	16 x 22	10	255
		62	25	320	160	280	18 x 22	10	255
		72	30	370	180	320	16 x 26	10	300
		82	30	390	190	340	18 x 26	10	300
		92	38	430	220	380	20 x 26	12	350
		102	38	470	240	420	22 x 26	12	350
112	42	510	260	450	18 x 33	12	400		
122	42	540	280	480	22 x 33	12	400		

Gövde Size Größe	Yağ miktarı / Oil quantity / Ölmenge (l) *)		Ağırlık / Weight / Gewicht (kg) **)**)		Soğutma serpantini / Cooling coil / Kühlschlange					
	Çıkış keçesi Shaft seal Wellendichtring	Labirent keçe Labyrinth seal / Labyrinthdichtung	SH HH DH KH	FH	Soğutma serpantini su bağlantısı G1/2" Water connection for cooling coil G1/2" Wasseranschluss für Kühlschlange G1/2"	Gövde Size Größe	b6	e6	h6	l/min x)
42	10	7	195	-		42	90	157	59	4
52	15	11	305	340		52	100	169	65	4
62	16	12	360	400		62	100	214	65	4
72	27	21	510	560		72	100	208	77	4
82	30	23	600	655		82	100	266	77	4
92	44	33	840	925		92	130	246	75	8
102	45	34	970	1060		102	130	294	75	8
112	74	58	1350	1480		112	140	275	90	8
122	82	60	1630	1770		122	140	360	90	8

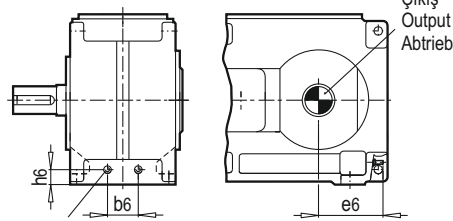

x) Gereklı soğutma suyu miktarı; basıncı 8 bar
Cooling water quantity required, max. cooling water pressure: 8 bar
Erforderliche Kühlwassermenge, max. kühlwasserdruck: 8 bar
Soğutma sistemi deniz suyu ve acı su için uygundur.
Cooling coil suitable for fresh, sea and brackish water
Kühlschlange geeignet für Süß- See- und Brackwasser

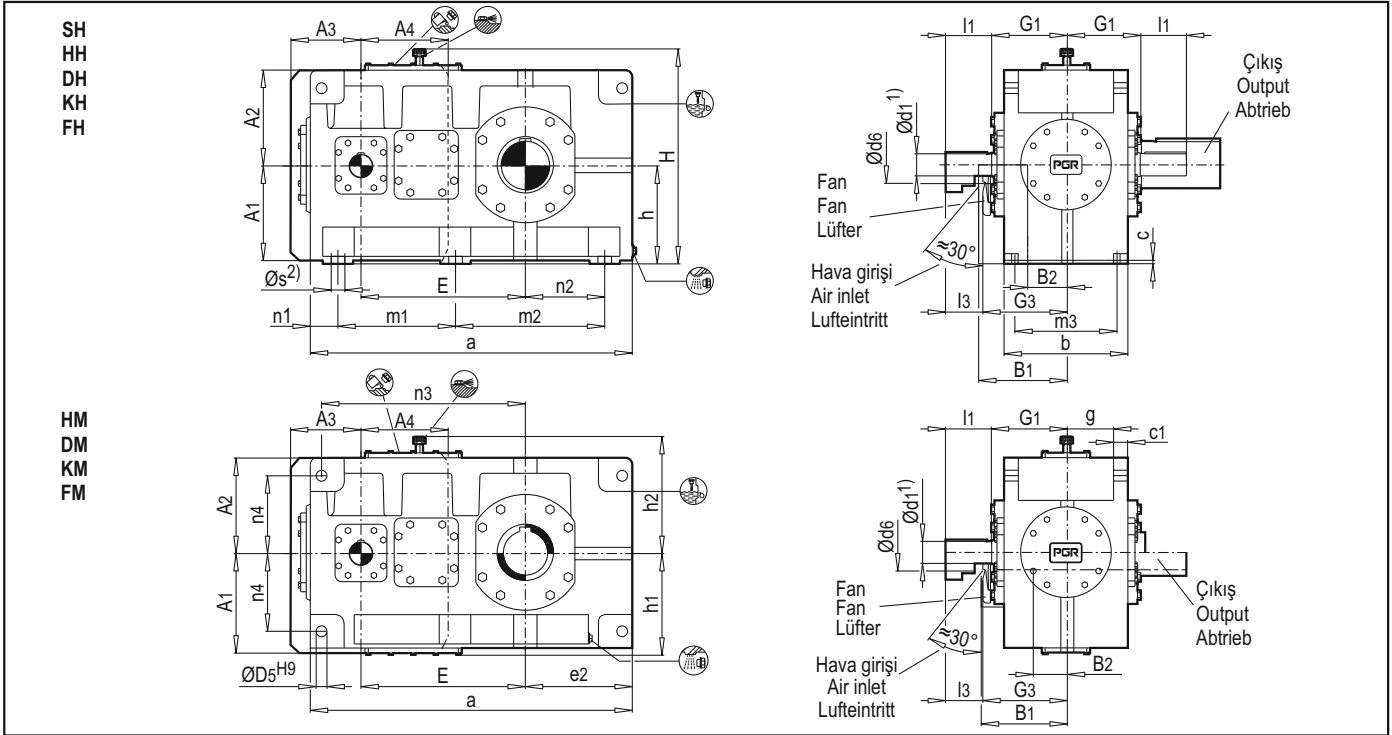

Gövde Size Größe	Giriş / Input / Antrieb															Fan / Fan / Lüfter											
	İN = 6.3 - 11.2			İN = 12.5 - 20			İN = 7.1 - 12.5			İN = 14 - 22.5			İN = 8 - 14			İN = 16 - 25			G1	G3	A1	A2	A3	A4	B1	B2	Ød6
	Ød1	l1	l3	Ød1	l1	l3	Ød1	l1	l3	Ød1	l1	l3	Ød1	l1	l3	Ød1	l1	l3									
132	100	205	170	85	170	135	-	-	-	-	-	-	-	-	-	-	-	330	365	432	462	332	367	387	137	250	
142	-	-	-	-	-	-	-	-	-	-	-	-	100	205	170	85	170	135	330	365	432	462	332	367	387	137	250
152	120	210	165	100	210	165	-	-	-	-	-	-	-	-	-	-	-	365	410	492	502	372	442	432	157	280	
162	-	-	-	-	-	-	120	210	165	100	210	165	-	-	-	-	-	365	410	492	502	372	442	432	157	280	
172	125	245	200	110	210	165	-	-	-	-	-	-	-	-	-	-	-	420	465	542	567	437	507	487	142	280	
182	-	-	-	-	-	-	125	245	200	110	210	165	-	-	-	-	-	420	465	542	567	437	507	487	142	280	
192	150	245	200	120	210	165	-	-	-	-	-	-	-	-	-	-	-	475	520	602	602	502	452	542	192	310	
202	-	-	-	-	-	-	150	245	200	120	210	165	-	-	-	-	-	475	520	602	602	502	452	542	192	310	
212	170	290	240	140	250	200	-	-	-	-	-	-	-	-	-	-	-	495	545	682	682	502	612	567	202	450	
222	-	-	-	-	-	-	170	290	240	140	250	200	-	-	-	-	-	495	545	682	682	502	612	567	202	450	

Gövde Size Größe	Redüktörler / Gear Units / Zahnradgetriebe															Kilit Backstop Rücklaufsperre						
	a	b	c	c1	ØD5	E	e2	g	H	h(-1)	h1	h2	m1	m2	m3	n1	n2	n3	n4	Øs	84	G8
132	1294	550	62	63	48	635	407	212	905	440	450	463	545	545	475	102	305	835	340	35		450
142	1434	550	62	63	48	705	477	212	905	440	450	463	545	685	475	102	375	905	340	35		450
152	1554	620	72	74	55	762	487	239	1005	500	490	503	655	655	535	122	365	1005	375	42		529
162	1644	625	72	74	55	808	532	239	1005	500	490	503	655	745	535	122	410	1050	375	42		529
172	1744	690	82	83	55	860	527	260	1115	550	555	563	735	735	600	137	390	1145	425	42		578
182	1864	690	82	83	55	920	587	260	1115	550	555	563	735	855	600	137	450	1205	425	42		578
192	2014	790	92	93	65	997	592	300	1245	620	615	623	850	850	690	157	435	1345	475	48		672
202	2134	790	92	93	65	1057	652	300	1245	620	615	623	850	970	690	157	495	1405	475	48		672
212	2144	830	102	102	75	1067	657	311	1395	700	685	693	900	900	720	172	485	1400	520	56		692
222	2254	830	102	102	75	1122	712	311	1395	700	685	693	900	1010	720	172	540	1455	520	56		692

Ölçüler mm'dir.

- Şaftlar**
m6<=Ø100; n6>Ø100
Kama kanalı DIN 6885/1.
Kama kanalı genişliği ISO JS9 a göre
Kama DIN 6885/1 form B'ye göre
Ayrıntılar için sayfa 127-136'ya bakılabilir.
- Bağlantı civatalarını takmadan önce havalandırma kapağını çıkartınız.
- Şaft montajlı redüktörlerde (PH...2-M) Labirent keçe yoktur.
- 132 ve 152 gövdelerin sadece İN= 6.3 - 18
172 ve 192 gövdelerin sadece İN= 6.3 - 16
- * Yaklaşık değerlerdir. Kesin verilere siparişte gönderilen dokümanlardan ulaşılabilir.
Mil keçesi için sayfa 159-161'e bakınız.
- ** Redüktörler yağsızdır.

Dimensions in mm

- Shafts:**
m6<=Ø100; n6>Ø100
Keyway acc.to DIN 6885/1.
Hub keyway width acc.to ISO JS9
Parallel key acc.to DIN 6885/1 form B
For details, see pages 127-136
- Remove air guide cover before fitting the foundation bolts.
- Shaft-mounted gear unit (PH...2-M) not with labyrinth seal
- Sizes 132 and 152 : only İN=6.3 - 18
Sizes 172 and 192 : only İN=6.3 - 16
- * Approximate values; exact data acc. to order related documentation.
For shaft seals, see pages 159-161
- ** Without oil filling

Abmessungen in mm

- Wellen:**
m6<=Ø100; n6>Ø100
Passfedermut nach DIN 6885/1
Nabennutbreite nach ISO JS9
Passfeder nach DIN 6885/1 Form B
Einzelheiten siehe Seiten 127-136
- Vor dem Befestigen der fußschrauben ist die Luftleithaube zu entfemen.
- Aufsteckgetriebe (PH...2-M) nicht mit Labyrinthdichtung.
- Größen 132 und 152 : nur İN= 6.3 - 18
Größen 172 und 192 : nur İN= 6.3 - 16
- * Richtwerte; genaue Angaben nach auftragsbezogener Dokumentation.
Wellenabdichtungen siehe seiten 159-161
- ** ohne Ölfüllung

TR İKİ KADEMELİ - YATAY

EN TWO STAGE - HORIZONTAL

DE ZWEISTUFIG - HORIZONTAL

	<p>PH132- SH ... PH222-SH Mil Çıkışlı Solid shaft Vollwelle</p>		Ød2	l2	G2
		132	200	350	335
		142	210	350	335
		152	230	410	380
		162	240	410	380
		172	250	410	415
		182	270	470	415
		192	290	470	465
		202	300	500	465
		212	320	500	490
222	340	550	490		

	<p>PH132-HH ... PH222-HH PH132-HM ... PH222-HM Delik millî Hollow shaft Hohlwelle</p>	3) 6)		ØD2	G2
		132	190	335	
		142	210	335	
		152	230	380	
		162	240	380	
		172	250	415	
		182	275	415	
		192	-	-	
		202	-	-	
		212	-	-	
222	-	-			

	<p>PH132-DH ... PH222-DH PH132-DM ... PH222-DM Konik Sıkırmalı Hollow shaft for shrink disk Hohlwelle für schrumpf- scheibe</p>	3) 6)		ØD2	ØD3	G4	G5
		132	190	195	335	480	
		142	210	215	335	480	
		152	230	235	380	550	
		162	240	245	380	550	
		172	250	260	415	600	
		182	280	285	415	600	
		192	285	295	465	670	
		202	310	315	465	670	
		212	330	335	490	715	
222	340	345	490	725			

	<p>PH132-KH ... PH222-KH PH132-KM ... PH222-KM Spline DIN 5480 Hollow shaft with involute splines acc. to DIN 5480 Hohlwelle mit Zahnaben- profil nach DIN 5480</p>	3) 6)		N / DIN 5480		ØD2	ØD3	G4
		132	N 190x5x30x36x9H		180	195	335	
		142	N 190x5x30x36x9H		180	215	335	
		152	N 220x5x30x42x9H		210	235	380	
		162	N 220x5x30x42x9H		210	245	380	
		172	N 250x5x30x48x9H		240	260	415	
		182	N 250x5x30x48x9H		240	285	415	
		192			İstek üzerine On request Auf Anfrage			
		202						
		212						
222								

	<p>PH132-FH ... PH222-FH PH132-FM ... PH222-FM Flanşlı shaft Flanged shaft Flanschswelle</p>		c	Ød2	ØD3	Øk2	n x Øs	t	G7
		132	48	580	310	500	20 x 33	14	480
		142	48	620	310	540	24 x 33	14	480
		152	55	710	360	630	28 x 33	17	550
		162	55	740	360	660	30 x 33	17	550
		172	60	750	410	660	24 x 39	18	600
		182	60	800	410	710	26 x 39	18	600
		192	65	860	460	770	30 x 39	18	670
		202	65	930	460	830	32 x 39	18	670
		212	75	950	520	850	28 x 45	20	710
222	75	1040	520	940	28 x 45	20	710		

Gövde Size Größe	Yağ miktar / Oil quantity / Ölmenge (l)*			Ağırlık / Weight / Gewicht (kg)***)				Soğutma serpantini Cooling coil / Kühlschlange	Gövde Size Größe	b6	e6	e7	h6	h7	l/min x)
	H Çıkış keçesi Shaft Wellen- dichtring	M labirent keçe / Labyrinth seal / Labyrinth- dichtung	M	SH HH DH KH	HM DM KM	FH	FM								
132	135	120	110	2030	1910	2190	2070	<p>Soğutma serpantini su bağlantısı G1/2" Water connection for cooling coil G1/2" Wasseranschluß für Kühlschlange G1/2"</p> <p>Çıkış Output Abtrieb</p> <p>Çıkış Output Abtrieb</p> <p>Soğutma sistemi deniz suyu ve acı su için uygundur Cooling coil suitable for fresh, sea and brackish water Kühlschlange geeignet für Süß-See- und Brackwasser</p>	252	455	335	116	300	8	
142	140	130	115	2600	2460	2770	2630		252	525	405	116	300	8	
152	210	190	160	3460	3270	3700	3510		290	535	395	119	335	8	
162	215	200	165	3700	3510	3955	3765		290	580	440	119	335	8	
172	290	260	230	4700	4470	5000	4770		340	575	425	134	380	8	
182	300	270	240	5150	4895	5525	5245		340	635	485	134	380	8	
192	320	-	300	6650	6350					İstek üzerine On request Auf Anfrage					
202	340	-	320	7550	7250										
212	320	-	350	8960	8460										
222	340	-	370	9700	9300										

x) Gereklî soğutma suyu miktarı; basıncı 8 bar
Cooling water quantity required, max. cooling water pressure: 8 bar
Erforderliche Kühlwassermenge, max. kühlwasserdruck: 8 bar

TR

ÜÇ KADEMELİ - YATAY

EN

THREE STAGE - HORIZONTAL

DE

DREISTUFIG - HORIZONTAL

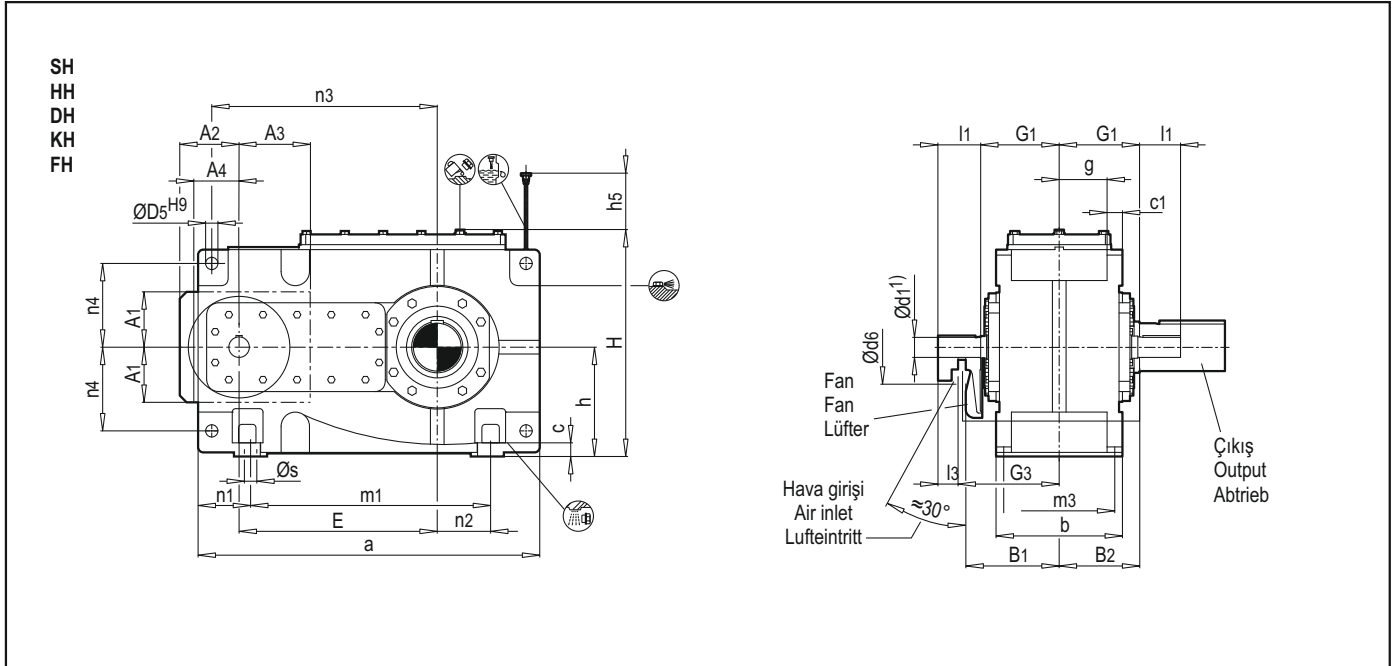

Gövde Size Größe	Giriş / Input / Antrieb												Fan / Fan / Lüfter														
	İN = 25 - 45			İN = 50 - 63			İN = 71 - 90			İN = 31.5 - 56			İN = 63 - 80			İN = 90 - 112			G1	G3	A1	A2	A3	A4	B1	B2	Ød6
	Ød1	l1	l3	Ød1	l1	l3	Ød1	l1	l3	Ød1	l1	l3	Ød1	l1	l3	Ød1	l1	l3									
53	40	70	70	30	50	50	24	40	40	-	-	-	-	-	-	-	-	-	160	220	139	137	142	82	217	177	60
63	-	-	-	-	-	-	-	-	-	40	70	70	30	50	50	24	40	40	160	220	139	137	142	82	217	177	60
73	45	80	80	35	60	60	28	50	50	-	-	-	-	-	-	-	-	-	185	250	159	162	182	102	247	207	75
83	-	-	-	-	-	-	-	-	-	45	80	80	35	60	60	28	50	50	185	250	159	162	182	102	247	207	75
93	60	125	105	45	100	80	32	80	60	-	-	-	-	-	-	-	-	-	230	300	184	192	207	122	297	242	90
103	-	-	-	-	-	-	-	-	-	60	125	105	45	100	80	32	80	60	230	300	184	192	207	122	297	242	90
113	70	120	120	50	80	80	42	70	70	-	-	-	-	-	-	-	-	-	255	330	220	222	257	152	327	282	100
123	-	-	-	-	-	-	-	-	-	70	120	120	50	80	80	42	70	70	255	330	220	222	257	152	327	282	100

Gövde Size Größe	Redüktörler / Gear Units / Zahnradgetriebe															Kilit Backstop Rücklaufsperre			
	a	b	c	c1	ØD5	E	g	H	h(-1)	h5	m1	m3	n1	n2	n3	n4	Øs	84	G8
53	694	255	30	31	24	405	98	487	230	130	480	220	107	100	455	180	19		236
63	774	255	30	31	24	440	98	487	230	130	560	220	107	145	490	180	19		236
73	849	300	37	37	28	495	115	577	280	170	605	260	122	130	560	215	24		289
83	954	300	37	37	28	540	115	587	280	160	710	260	122	190	605	215	24		289
93	1004	370	42	47	36	580	141	667	320	185	710	320	147	155	660	245	28		319
103	1104	370	42	47	36	630	141	667	320	185	810	320	147	205	710	245	28		319
113	1204	430	52	56	40	705	162	787	380	180	870	370	167	180	805	300	35		371
123	1359	430	52	56	40	775	162	797	380	170	1025	370	167	265	875	300	35		371

Ölçüler mm'dir.

1) Şaftlar

k6=Ø24; Ø28≤m6≤Ø100; n6>Ø100

Kama kanalı DIN 6885/1,

Kama kanalı genişliği ISO JS9 a göre

Kama DIN 6885/1 form B

Ayrıntılar için sayfa 127-136'ya bakılabilir

*) Yaklaşık değerlerdir. Kesin verilere siparişte gönderilen dökümanlardan ulaşılabilir.

**) Redüktörler yağsızdır.

Dimensions in mm

1) Shafts:

k6=Ø24; Ø28≤m6≤Ø100; n6>Ø100

Keyway acc.to DIN 6885/1,

Hub keyway width acc.to ISO JS9

Parallel key acc.to DIN 6885/1 form B

For details, see pages 127-136

*) Approximate values; exact data acc. to order related documentation.

**) Without oil filling

Abmessungen in mm

1) Wellen:

k6=Ø24; Ø28≤m6≤Ø100; n6>Ø100

Passfedernut nach DIN 6885/1

Nabennutbreite nach ISO JS9

Passfeder nach DIN 6885/1 Form B

Einzelheiten siehe Seiten 127-136

*) Richtwerte; genaue Angaben nach auftragsbezogener Dokumentation.

**) ohne Ölfüllung

TR ÜÇ KADEMELİ - YATAY

EN THREE STAGE - HORIZONTAL

DE DREISTUFIG - HORIZONTAL

	<p>PH53-SH ... PH123-SH Mil Çıkışı Solid shaft Vollwelle</p>		Ød2	l2	G2
		53	100	210	165
		63	110	210	165
		73	120	210	195
		83	130	250	195
		93	140	250	235
		103	160	300	235
		113	170	300	270
123	180	300	270		

	<p>PH53-HH ... PH123-HH Delik milli Hollow shaft Hohlwelle</p>		ØD2	G4
		53	95	165
		63	105	165
		73	115	195
		83	125	195
		93	135	235
		103	150	235
		113	165	270
123	180	270		

	<p>PH53-DH ... PH123-DH Konik Sıktırma Hollow shaft for shrink disk Hohlwelle für schrumpfscheibe</p>		ØD2	ØD3	G4	G5
		53	100	100	165	240
		63	110	110	165	240
		73	120	120	195	280
		83	130	130	195	285
		93	140	145	235	330
		103	150	155	235	350
		113	165	170	270	400
123	180	185	270	405		

	<p>PH53-KH ... PH123-KH Spline DIN 5480 Hollow shaft with involute splines acc. to DIN 5480 Hohlwelle mit Zahnradprofil nach DIN 5480</p>		N / DIN 5480	ØD2	ØD3	G4
		53	N 95x3x30x30x9H	89	100	165
		63	N 95x3x30x30x9H	89	110	165
		73	N 120x3x30x38x9H	114	120	195
		83	N 120x3x30x38x9H	114	130	195
		93	N 140x3x30x45x9H	134	145	235
		103	N 140x3x30x45x9H	134	155	235
		113	N 170x5x30x32x9H	160	170	270
123	N 170x5x30x32x9H	160	185	270		

	<p>PH53-FH ... PH123-FH Flanşlı şaft Flanged shaft Flanschswelle</p>		c	Ød2	ØD3	Øk2	n x Øs	t	G7
		53	25	300	150	260	16 x 22	10	255
		63	25	320	160	280	18 x 22	10	255
		73	30	370	180	320	16 x 26	10	300
		83	30	390	190	340	18 x 26	10	300
		93	38	430	220	380	20 x 26	12	350
		103	38	470	240	420	22 x 26	12	350
		113	42	510	260	450	18 x 33	12	400
123	42	540	280	480	22 x 33	12	400		

Gövde Size Größe	Yağ miktarı Oil quantity Ölmenge (l)*	Ağırlık / Weight Gewicht (kg)****)	
		SH HH DH KH	FH
53	16	325	360
63	18	370	410
73	30	550	600
83	35	635	685
93	48	890	975
103	52	1040	1130
113	85	1430	1560
123	93	1705	1845

Soğutma serpantini / Cooling coil / Kühlschlange				
Gövde Size Größe	b6	e6	h6	l/min x)
53	100	169	65	4
63	100	214	65	4
73	100	208	77	4
83	80	266	77	4
93	130	246	75	4
103	130	294	75	4
113	140	275	90	8
123	140	360	90	8

Soğutma serpantini su bağlantısı G1/2"
Water connection for cooling coil G1/2"
Wasseranschluß für Kühlschlange G1/2"

Çıkış
Output
Abtrieb

Soğutma sistemi deniz suyu ve acı su için uygundur
Cooling coil suitable for fresh, sea and brackish water
Kühlschlange geeignet für Süß-See- und Brackwasser

x) Gerekli soğutma suyu miktarı; basıncı 8 bar
Cooling water quantity required, max. cooling water pressure: 8 bar
Erforderliche Kühlwassermenge, max. kühlwasserdruck: 8 bar

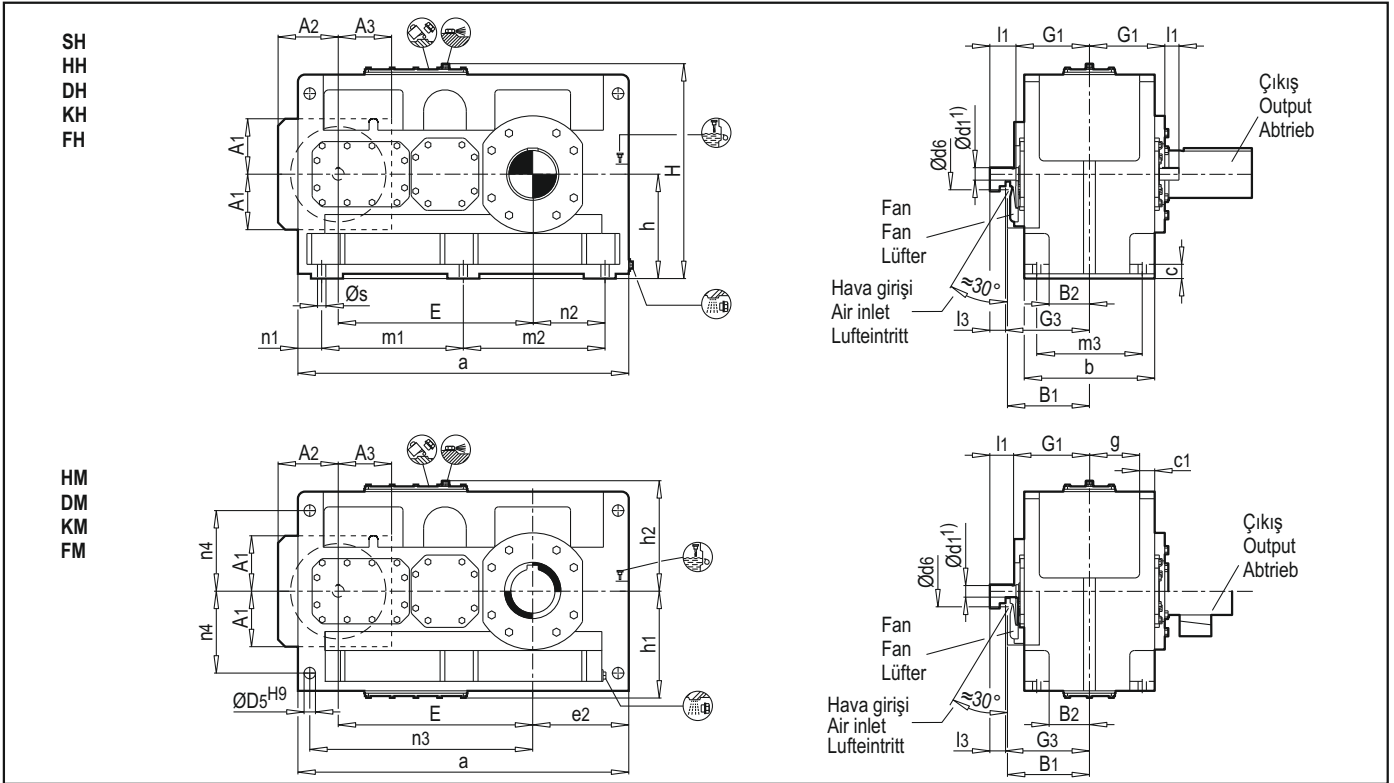

Gövde Size Größe	Giriş / Input / Antrieb															Fan / Fan / Lüfter										
	İN = 22.4 - 45			İN = 50 - 63			İN = 71 - 90			İN = 25 - 50			İN = 56 - 71			İN = 80 - 100			G1	G3	A1	A2	A3	B1	B2	Ød6
	Ød1	l1	l3	Ød1	l1	l3	Ød1	l1	l3	Ød1	l1	l3	Ød1	l1	l3	Ød1	l1	l3								
133	85	160	130	60	135	105	50	110	80	-	-	-	-	-	-	-	-	-	310	385	227	227	214	382	197	120
143	-	-	-	-	-	-	-	-	-	85	160	130	60	135	105	50	110	80	310	385	227	227	214	382	197	120
153	100	200	165	75	140	105	60	140	105	-	-	-	-	-	-	-	-	-	350	420	272	267	254	417	207	150
163	-	-	-	-	-	-	-	-	-	100	200	165	75	140	105	60	140	105	350	420	272	267	254	417	207	150
173	100	200	165	75	140	105	60	140	105	-	-	-	-	-	-	-	-	-	380	450	272	267	254	457	237	150
183	-	-	-	-	-	-	-	-	-	100	200	165	75	140	105	60	140	105	380	450	272	267	254	457	237	150
193	110	200	-	90	165	-	75	140	-	-	-	-	-	-	-	-	-	-	430	-	İstek üzerine On request Auf Anfrage					
203	-	-	-	-	-	-	-	-	110	200	-	90	165	-	75	140	-	430	-							
213	130	240	-	110	205	-	90	170	-	-	-	-	-	-	-	-	-	470	-							
223	-	-	-	-	-	-	-	-	130	240	-	110	205	-	90	170	-	470	-							

Gövde Size Größe	Redüktörler / Gear Units / Zahnradgetriebe																	Kilit Backstop Rücklaufsperre			
	a	b	c	c1	ØD5	E	e2	g	H	h(-1)	h1	h2	m1	m2	m3	n1	n2	n3	n4	Øs	84
133	1399	550	62	63	48	820	407	212	905	440	450	463	597.5	597.5	475	102	305	940	340	35	459
143	1539	550	62	63	48	890	477	212	905	440	450	463	597.5	737.5	475	102	375	1010	340	35	459
153	1684	620	72	74	55	987	487	239	1005	500	490	503	720	720	535	122	365	1135	375	42	524
163	1774	620	72	74	55	1033	532	239	1005	500	490	503	720	810	535	122	410	1180	375	42	524
173	1774	690	82	83	55	1035	527	260	1115	550	555	563	750	750	600	137	390	1175	425	42	536
183	1894	690	82	83	55	1095	587	260	1115	550	555	563	750	870	600	137	450	1235	425	42	536
193	2034	790	92	93	65	1190	592	300	1245	620	615	623	860	860	690	157	435	1365	475	48	616
203	2154	790	92	93	65	1250	652	300	1245	620	615	623	860	980	690	157	495	1425	475	48	616
213	2344	830	102	102	75	1387	657	311	1395	700	685	693	1000	1000	720	172	485	1600	520	56	637
223	2454	830	102	102	75	1442	712	311	1395	700	685	693	1000	1110	720	172	540	1655	520	56	637

+) Max ölçülerdir. Ayrıntılara siparişte gönderilen dokümanlardan ulaşılabilir.
Ölçüler mm'dir.

1) **Şaftlar:**
m6<=Ø100; n6>Ø100
Kama kanalı DIN 6885/1,
Kama kanalı genişliği ISO JS9 a göre
Kama DIN 6885/1 form B
Ayrıntılar için sayfa 127-136'ya bakılabilir.

*) Yaklaşık değerlerdir. Kesin verilere siparişte gönderilen dokümanlardan ulaşılabilir.

**) Redüktörler yağsızdır.

+) Max. dimensions; details acc. to order-related documentation

Dimensions in mm

1) **Shafts:**
m6<=Ø100; n6>Ø100
Keyway acc.to DIN 6885/1,
Hub keyway width acc.to ISO JS9
Parallel key acc.to DIN 6885/1 form B
For details, see pages 127-136

*) Approximate values; exact data acc. to order related documentation.

**) Without oil filling

+) max. Abmessungen; Einzelheiten nach auftragsbezogener Dokumentation.
Abmessungen in mm

1) **Wellen:**
m6<=Ø100; n6>Ø100
Passfedernut nach DIN 6885/1
Nabennutbreite nach ISO JS9
Passfeder nach DIN 6885/1 Form B
Einzelheiten siehe Seiten 127-136

*) Richtwerte; genaue Angaben nach auftragsbezogener Dokumentation.

**) ohne Ölfüllung

TR ÜÇ KADEMELİ - YATAY

EN THREE STAGE - HORIZONTAL

DE DREISTUFIG - HORIZONTAL

	<p>PH133-SH ... PH223-SH Mil Çıkışı Solid shaft Vollwelle</p>		Ød2	l2	G2
		133	200	350	335
		143	210	350	335
		153	230	410	380
		163	240	410	380
		173	250	410	415
		183	270	470	415
		193	290	470	465
		203	300	500	465
		213	320	500	490
223	340	550	490		

	<p>PH133-HH ... PH223-HH PH133-HM ... PH223-HM Delik millî Hollow shaft Hohlwelle</p>		ØD2	G4
		133	190	335
		143	210	335
		153	230	380
		163	240	380
		173	250	415
		183	275	415
		193	-	-
		203	-	-
		213	-	-
223	-	-		

	<p>PH133-DH ... PH223-DH PH133-DM ... PH223-DM Konik Sıktırmalı Hollow shaft for shrink disk Hohlwelle für schrumpfscheibe</p>		ØD2	ØD3	G4	G5
		133	190	195	335	480
		143	210	215	335	480
		153	230	235	380	550
		163	240	245	380	550
		173	250	260	415	600
		183	280	285	415	600
		193	285	295	465	670
		203	310	315	465	670
		213	330	335	490	715
223	340	345	490	725		

	<p>PH133-KH ... PH223-KH PH133-KM ... PH223-KM Spline DIN 5480 Hollow shaft with involute splines acc. to DIN 5480 Hohlwelle mit Zahnradprofil nach DIN 5480</p>		N / DIN 5480	ØD2	ØD3	G4
		133	N 190x5x30x36x9H	180	195	335
		143	N 190x5x30x36x9H	180	215	335
		153	N 220x5x30x42x9H	210	235	380
		163	N 220x5x30x42x9H	210	245	380
		173	N 250x5x30x48x9H	240	260	415
		183	N 250x5x30x48x9H	240	285	415
		193				
		203				İstek üzerine
		213				On request
223				Auf Anfrage		

	<p>PH133-FH ... PH223-FH PH133-FM ... PH223-FM Flanşlı şaft Flanged shaft Flanschelle</p>		c	Ød2	ØD3	Øk2	n x Øs	t	G7
		133	48	580	310	500	20 x 33	14	480
		143	48	620	310	540	24 x 33	14	480
		153	55	710	360	630	28 x 33	17	550
		163	55	740	360	660	30 x 33	17	550
		173	60	750	410	660	24 x 39	18	600
		183	60	800	410	710	26 x 39	18	600
		193	65	860	460	770	30 x 39	18	670
		203	65	930	460	830	32 x 39	18	670
		213	75	950	520	850	28 x 45	20	710
223	75	1040	520	940	28 x 45	20	710		

Gövde Size Größe	Yağ miktarı Oil quantity Ölmenge (l)*		Ağırlık / Weight / Gewicht (kg)****)				Soğutma serpantini / Cooling coil / Kühlschlange						
	H	M	SH HH DH KH	HM DM KM	FH	FM	Soğutma serpantini su bağlantısı G1/2" Water connection for cooling coil G1/2" Wasseranschluß für Kühlschlange G1/2"						
133	160	125	2320	2180	2480	2330							
143	165	130	2650	2515	2820	2685							
153	235	190	3500	3285	3740	3525							
163	245	195	3910	3660	4165	3915							
173	305	240	4595	4285	4895	4585							
183	315	250	5070	4780	5900	5130							
193	420	390	6750	6250									
203	450	415	8150	7650									
213	470	515	9200	8600									
223	490	540	9900	9400									

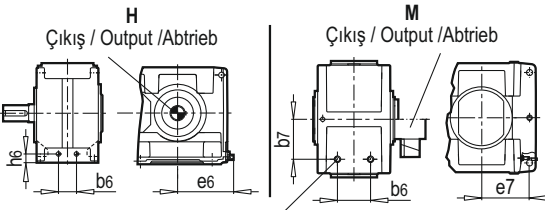

Soğutma sistemi deniz suyu ve acı su için uygundur.
Cooling coil suitable for fresh, sea and brackish water
Kühlschlange geeignet für Süß- See- und Brackwasser

x) Gerekli soğutma suyu miktarı; basıncı 8 bar
Cooling water quantity required, max. cooling water pressure: 8 bar
Erforderliche Kühlwassermenge, max. kühlwasserdruck: 8 bar

TR

DÖRT KADEMELİ - YATAY

EN

FOUR STAGE - HORIZONTAL

DE

VIERSTUFIG - HORIZONTAL

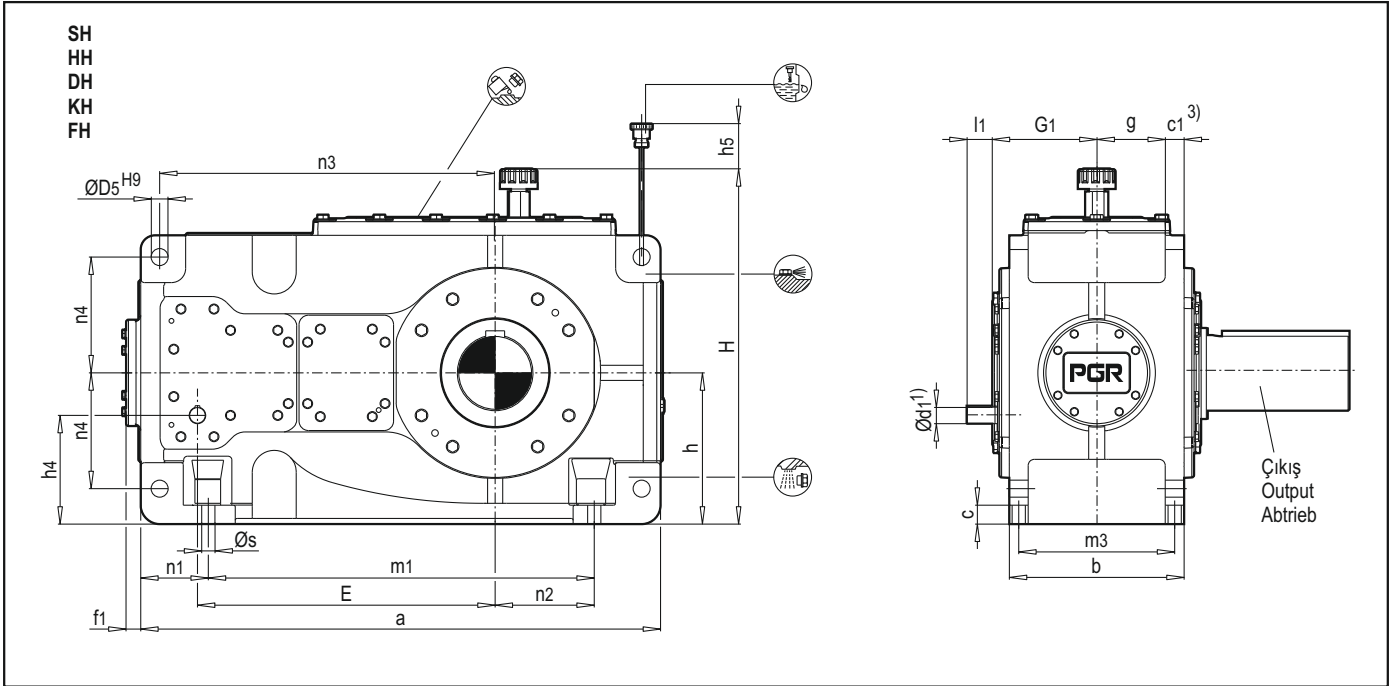

Gövde Size Größe	Giriş / Input / Antrieb									
	İN = 100 - 180		İN = 200 - 355		İN = 125 - 224		İN = 250 - 450		G1	
	Ød1	l1	Ød1	l1	Ød1	l1	Ød1	l1		
74	30	50	24	40	-	-	-	-		180
84	-	-	-	-	30	50	24	40		180
94	35	60	28	50	-	-	-	-		215
104	-	-	-	-	35	60	28	50		215
114	45	100	32	80	-	-	-	-		250
124	-	-	-	-	45	100	32	80		250

Gövde Size Größe	Redüktörler / Gear Units / Zahnradgetriebe																		Kilit Backstop Rücklaufsperre		
	a	b	c	c1	ØD5	E	f1	g	H	h(-1)	h4	h5	m1	m3	n1	n2	n3	n4	Øs	84	G8
74	849	300	37	37	28	495	37	115	577	280	200	140	605	260	122	130	560	215	24		288
84	954	300	37	37	28	540	37	115	587	280	200	140	710	260	122	190	605	215	24		288
94	1004	370	42	47	36	580	43	141	667	320	230	150	710	320	147	155	660	245	28		319
104	1104	370	42	47	36	630	43	141	667	320	230	150	810	320	147	205	710	245	28		319
114	1204	430	52	56	40	705	47	162	787	380	270	165	870	370	167	180	805	300	35		335
124	1359	430	52	56	40	775	47	162	795	380	270	165	1025	370	167	265	875	300	35		335

+) Max ölçülerdir. Ayrıntılara siparişte gönderilen dokümanlardan ulaşılabilir.
Ölçüler mm'dir.

1) Şaftlar:

k6=Ø24; Ø28≤m6≤Ø100; n6>Ø100

Kama kanalı DIN 6885/1,

Kama kanalı genişliği ISO JS9 a göre

Kama DIN 6885/1 form B

Ayrıntılar için sayfa 127-136'ya bakılabilir.

*) Yaklaşık değerlerdir. Kesin verilere siparişte gönderilen dokümanlardan ulaşılabilir.

***) Redüktörler yağsızdır.

+) Max. dimensions; details acc. to order-related documentation.

Dimensions in mm

1) Shafts:

k6=Ø24; Ø28≤m6≤Ø100; n6>Ø100

Keyway acc.to DIN 6885/1,

Hub keyway width acc.to ISO JS9

Parallel key acc.to DIN 6885/1 form B

For details, see pages 127-136.

*) Approximate values; exact data acc. to order related documentation.

***) Without oil filling

+) max. Abmessungen; Einzelheiten nach auftragsbezogener Dokumentation.
Abmessungen in mm

1) Wellen:

k6=Ø24; Ø28≤m6≤Ø100; n6>Ø100

Passfedernut nach DIN 6885/1

Nabennutbreite nach ISO JS9

Passfeder nach DIN 6885/1 Form B

Einzelheiten siehe Seiten 127-136.

*) Richtwerte; genaue Angaben nach auftragsbezogener Dokumentation.

***) ohne Öfüllung

TR DÖRT KADEMELİ - YATAY

EN FOUR STAGE - HORIZONTAL

DE VIERSTUFIG - HORIZONTAL

	<p>PH74-SH ... PH124-SH Mil Çıkışlı Solid shaft Vollwelle</p>		Ød2	l2	G2
		74	120	210	195
		84	130	250	195
		94	140	250	235
		104	160	300	235
		114	170	300	270
124	180	300	270		

	<p>PH74-HH ... PH124-HH Delik millî Hollow shaft Hohlwelle</p>		ØD2	G4
		74	115	195
		84	125	195
		94	135	235
		104	150	235
		114	165	270
124	180	270		

	<p>PH74-DH ... PH124-DH Konik Sıktırmalı Hollow shaft for shrink disk Hohlwelle für schrumpfscheibe</p>		ØD2	ØD3	G4	G5
		74	120	120	195	280
		84	130	130	195	285
		94	140	145	235	330
		104	150	155	235	350
		114	165	170	270	400
124	180	185	270	405		

	<p>PH74-KH ... PH124-KH Spline DIN 5480 Hollow shaft with involute splines acc. to DIN 5480 Hohlwelle mit Zahnablen profil nach DIN 5480</p>		N / DIN 5480	ØD2	ØD3	G4
		74	N 120x3x30x38x9H	114	120	195
		84	N 120x3x30x38x9H	114	130	195
		94	N 140x3x30x45x9H	134	145	235
		104	N 140x3x30x45x9H	134	155	235
		114	N 170x5x30x32x9H	160	170	270
124	N 170x5x30x32x9H	160	185	270		

	<p>PH74-FH ... PH124-FH Flanşlı şaft Flanged shaft Flanschswelle</p>		c	Ød2	ØD3	Øk2	n x Øs	t	G7
		74	30	370	180	320	16 x 26	10	300
		84	30	390	190	340	18 x 26	10	300
		94	38	430	220	380	20 x 26	12	350
		104	38	470	240	420	22 x 26	12	350
		114	42	510	260	450	18 x 33	12	400
124	42	540	280	480	22 x 33	12	400		

Gövde Size Größe	Yağ miktarı Oil quantity Ölmenge (l)*	Ağırlık Weight / Gewicht (kg)***)	
		SH HH DH KH	FH
74	29	560	610
84	32	655	710
94	49	890	975
104	50	1030	1130
114	85	1480	1610
124	96	1750	1890

TR DÖRT KADEMELİ - YATAY

EN FOUR STAGE - HORIZONTAL

DE VIERSTUFIG - HORIZONTAL

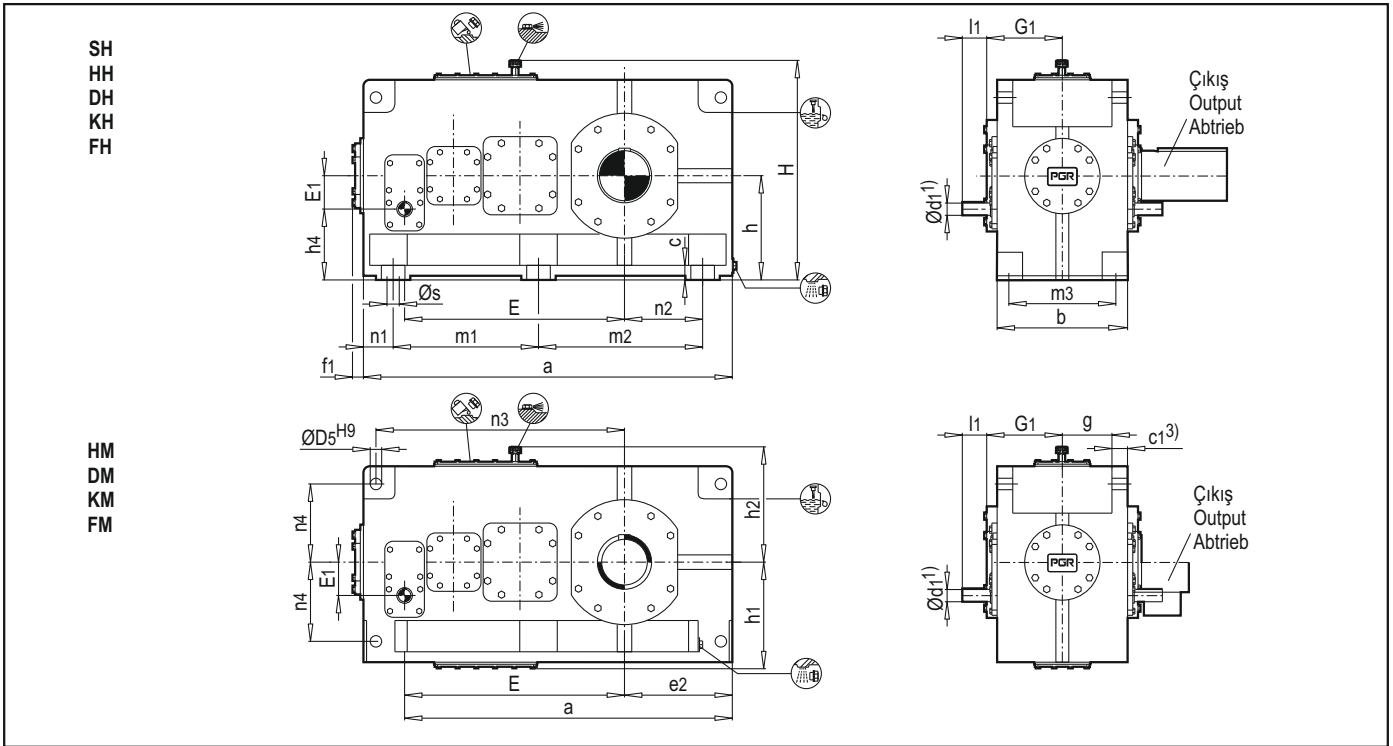

Gövde Size Größe	Giriş / Input / Antrieb												G1
	İN = 100 - 180		İN = 200 - 355		İN = 112 - 200		İN = 224 - 400		İN = 125 - 224		İN = 250 - 450		
	Ød1	l1	Ød1	l1	Ød1	l1	Ød1	l1	Ød1	l1	Ød1	l1	
134	50	100	38	80	-	-	-	-	-	-	-	-	305
144	-	-	-	-	-	-	-	-	50	100	38	80	305
154	60	135	50	110	-	-	-	-	-	-	-	-	345
164	-	-	-	-	60	135	50	110	-	-	-	-	345
174	60	105	50	80	-	-	-	-	-	-	-	-	380
184	-	-	-	-	60	105	50	80	-	-	-	-	380
194	75	105	60	105	-	-	-	-	-	-	-	-	440
204	-	-	-	-	75	105	60	105	-	-	-	-	440
214	90	165	70	140	-	-	-	-	-	-	-	-	460
224	-	-	-	-	90	165	70	140	-	-	-	-	460

Gövde Size Größe	Redüktörler / Gear Units / Zahnradgetriebe																				Kilit Backstop Rücklaufsperre			
	a	b	c	c1	ØD5	E	E1	e2	f1	g	H	h(-1)	h1	h2	h4	m1	m2	m3	n1	n2	n3	n4	Øs	84
134	1399	550	62	63	48	820	130	407	47	212	905	440	450	460	310	597.5	597.5	475	100	307	940	340	35	393
144	1539	550	62	63	48	890	130	477	47	212	905	440	450	460	310	597.5	737.5	475	100	377	1010	340	35	393
154	1684	620	72	74	55	987	160	487	56	239	1005	500	490	500	340	720	720	535	120	367	1135	375	42	489
164	1774	620	72	74	55	1033	160	532	56	239	1005	500	490	500	340	720	810	535	120	412	1180	375	42	489
174	1774	690	82	83	55	1035	160	527	53	260	1115	550	555	560	390	750	750	600	135	392	1175	425	42	489
184	1894	690	82	83	55	1095	160	587	53	260	1115	550	555	560	390	750	870	600	135	452	1235	425	42	489
194	2034	790	92	93	65	1190	185	592	53	300	1245	620	615	620	435	860	860	690	155	437	1365	475	48	592
204	2154	790	92	93	65	1250	185	652	53	300	1245	620	615	620	435	860	980	690	155	497	1425	475	48	592
214	2344	830	102	102	75	1387	225	657	62	311	1395	700	685	690	475	1000	1000	720	170	487	1600	520	56	612
224	2454	830	102	102	75	1442	225	712	62	311	1395	700	685	690	475	1000	1110	720	170	542	1655	520	56	612

+) Max ölçülerdir. Ayrıntılara siparişte gönderilen dokümanlardan ulaşılabilir.
Ölçüler mm'dir.

1) **Şaftlar:**
m6<=Ø100; n6>Ø100
Kama kanalı DIN 6885/1,
Kama kanalı genişliği ISO JS9 a göre
Kama DIN 6885/1 form B
Ayrıntılar için sayfa 127-136'ya bakılabilir.

*) Yaklaşık değerlerdir. Kesin verilere siparişte gönderilen dokümanlardan ulaşılabilir.

***) Redüktörler yağsızdır.

+) Max. dimensions; details acc.to order-related documentation.

Dimensions in mm

1) **Shafts:**
m6<=Ø100; n6>Ø100
Keyway acc.to DIN 6885/1,
Hub keyway width acc.to ISO JS9
Parallel key acc.to DIN 6885/1 form B
For details, see pages 127-136

*) Approximate values; exact data acc. to order related documentation.

***) Without oil filling

+) max. Abmessungen; Einzelheiten nach auftragsbezogener Dokumentation.

Abmessungen in mm

1) **Wellen:**
m6<=Ø100; n6>Ø100
Passfedermut nach DIN 6885/1
Nabennutbreite nach ISO JS9
Passfeder nach DIN 6885/1 Form B
Einzelheiten siehe Seiten 127-136

*) Richtwerte; genaue Angaben nach auftragsbezogener Dokumentation.

***) ohne Ölfüllung

TR DÖRT KADEMELİ - YATAY

EN FOUR STAGE - HORIZONTAL

DE VIERSTUFIG - HORIZONTAL

	<p>PH134-SH ... PH224-SH Mil Çıkışlı Solid shaft Vollwelle</p>		Ød2	l2	G2
		134	200	350	335
		144	210	350	335
		154	230	410	380
		164	240	410	380
		174	250	410	415
		184	270	470	415
		194	290	470	465
		204	300	500	465
		214	320	500	490
224	340	550	490		

	<p>PH134-HH ... PH224-HH PH134-HM ... PH224-HM Delik milli Hollow shaft Hohlwelle</p>		ØD2	G4
		134	190	335
		144	210	335
		154	230	380
		164	240	380
		174	250	415
		184	275	415
		194	-	-
		204	-	-
		214	-	-
224	-	-		

	<p>PH134-DH ... PH224-DH PH134-DM ... PH224-DM Konik Sıktırmalı Hollow shaft for shrink disk Hohlwelle für schrumpfscheibe</p>		ØD2	ØD3	G4	G5
		134	190	195	335	480
		144	210	215	335	480
		154	230	235	380	550
		164	240	245	380	550
		174	250	260	415	600
		184	280	285	415	600
		194	285	295	465	670
		204	310	315	465	670
		214	330	335	490	715
224	340	345	490	725		

	<p>PH134-KH ... PH224-KH PH134-KM ... PH224-KM Spline DIN 5480 Hollow shaft with involute splines acc. to DIN 5480 Hohlwelle mit Zahnablenprofil nach DIN 5480</p>		N / DIN 5480	ØD2	ØD3	G4
		134	N 190x5x30x36x9H	180	195	335
		144	N 190x5x30x36x9H	180	215	335
		154	N 220x5x30x42x9H	210	235	380
		164	N 220x5x30x42x9H	210	245	380
		174	N 250x5x30x48x9H	240	260	415
		184	N 250x5x30x48x9H	240	285	415
		194				
		204				
		214				
224						

	<p>PH134-FH ... PH224-FH PH134-FM ... PH224-FM Flanşlı shaft Flanged shaft Flanschelle</p>		c	Ød2	ØD3	Øk2	n x Øs	t	G7
		134	48	580	310	500	20 x 33	14	480
		144	48	620	310	540	24 x 33	14	480
		154	55	710	360	630	28 x 33	17	550
		164	55	740	360	660	30 x 33	17	550
		174	60	750	410	660	24 x 39	18	600
		184	60	800	410	710	26 x 39	18	600
		194	65	860	460	770	30 x 39	18	670
		204	65	930	460	830	32 x 39	18	670
		214	75	950	520	850	28 x 45	20	710
224	75	1040	520	940	28 x 45	20	710		

Gövde Size Größe	Yağ miktarı Oil quantity Ölmenge (l)*		Ağırlık Weight / Gewicht (kg)**			
	H	M	SH HH DH KH	HM DM KM	FH	FM
134	130	120	2400	2280	2560	2440
144	140	125	2750	2620	2920	2790
154	230	170	3655	3460	3895	3700
164	235	175	3990	3765	4245	4020
174	290	225	4710	4475	5010	4775
184	305	230	5220	5950	5570	5300
194	430	310	6850	6350		
204	380	330	8250	7750		
214	395	430	9270	8670		
224	420	450	9990	9490		

HELİSEL DİŞLİLİ REDÜKTÖRLER / HELICAL GEAR UNITS / STIRNRADGETRIEBE

İki kademe, Yatay / Double stage, Horizontal / Zweistufig, Horizontal - PH42-H ... 222-H / PH132-M ... 222-M 1)					
A	B	C	D	E	F
Üç kademe, Yatay / Three stage, Horizontal / Dreistufig, Horizontal - PH53-H ... 223-H / PH133-M ... 223-M 1)					
A	B	C	D	E	F
Dört kademe, Yatay / Four stage, Horizontal / Vierstufig, Horizontal - PH74-H ... 124-H 1)					
A	B	C	D	E	F
<p>■ Kilit: Gövde 74-104 / Backstop: Sizes 74-104 / Rücklaufsperr: Größen 74-104 <input type="checkbox"/> Kilit: Gövde 114-124 / Backstop: Sizes 114-124 / Rücklaufsperr: Größen 114-124</p>					
Dört kademe, Yatay / Four stage, Horizontal / Vierstufig, Horizontal - PH134-H ... 224-H / PH134-M ... 224-M 1)					
A	B	C	D	E	F

1) Değişkenler:

G,H ve I tasarımlar ile kilit mümkün değil.

1) Variants:

Backstop not possible with G,H and I designs.

1) Varianten:

Rücklaufsperr nicht in Verbindung mit Ausführung G,H und I

■ Kilit / Backstop / Rücklaufsperr

Ölçü Tabloları

Dimension Tables

Größe Tabellen

PB...

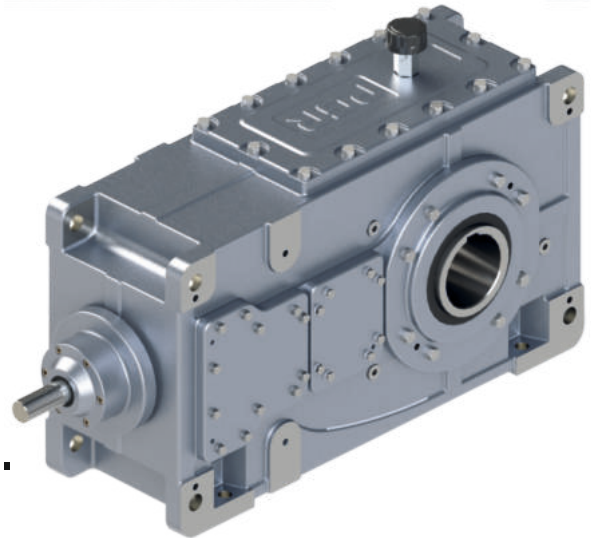

İKİ KADEME / DOUBLE STAGE / ZWEISTUFIG

ÜÇ KADEME / THREE STAGE / DREISTUFIG

DÖRT KADEME / FOUR STAGE / VIERSTUFIG

PB SERİSİ / YATAY
PB SERIES / HORIZONTAL
PB SERIE / HORIZONTAL

TR

İKİ KADEMELİ - YATAY

EN

TWO STAGE - HORIZONTAL

DE

ZWEISTUFIG - HORIZONTAL

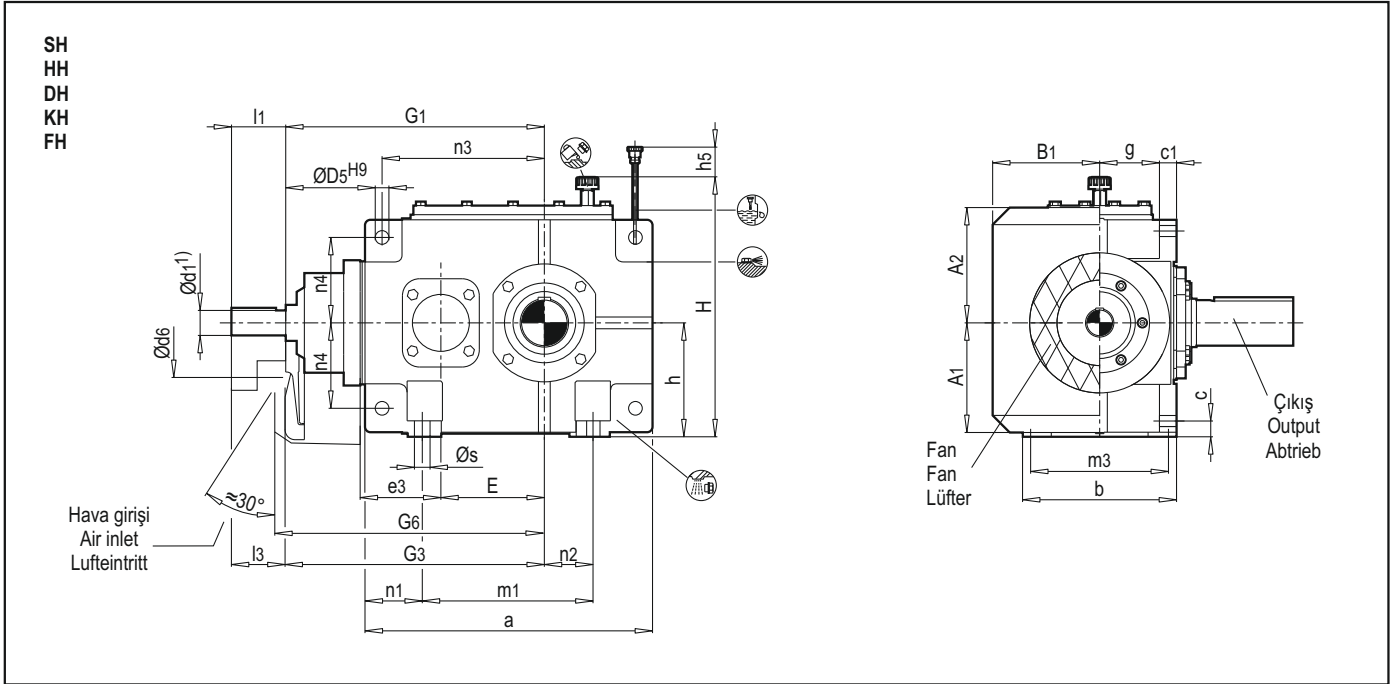

Gövde Size Größe	Giriş / Input / Antrieb						Fan / Fan / Lüfter					
	İN = 5 - 11.2			İN = 6.3 - 14			G1	G3	A1	A2	B1	Ød6
Ød1	l1	l3	Ød1	l1	l3							
42	45	100	80	-	-	-	465	485	197	202	190	150
52	55	110	80	-	-	-	535	565	222	237	217	160
62	-	-	-	55	110	80	570	600	222	237	217	160
72	70	135	105	-	-	-	640	670	272	287	252	210
82	-	-	-	70	135	105	685	715	272	287	252	210
92	80	165	130	-	-	-	755	790	312	327	272	195
102	-	-	-	80	165	130	805	840	312	327	272	195
112	90	165	130	-	-	-	925	960	372	387	330	210
122	-	-	-	90	165	130	995	1030	372	387	330	210

Gövde Size Größe	Redüktörler / Gear Units / Zahnradgetriebe																	Kilit Backstop Rücklaufsperre			
	a	b	c	c1	ØD5	E	e3	g	G6	H	h(-1)	h5	m1	m3	n1	n2	n3	n4	Øs	98	G8
42	509	270	30	31	24	160	160	106	495	420	200	80	295	235	107	85	285	150	19	286	
52	569	320	30	31	24	185	185	131	575	487	230	150	355	285	107	100	330	180	19	325	
62	649	320	30	31	24	220	185	131	610	487	230	150	435	285	107	145	365	180	19	325	
72	694	380	37	37	28	225	225	155	685	587	280	180	450	340	122	130	405	215	24	377	
82	799	380	37	37	28	270	225	155	730	587	280	190	555	340	122	190	450	215	24	377	
92	824	440	42	50	36	265	265	173	805	667	320	205	530	390	147	155	480	245	28	454	
102	924	440	42	50	36	315	265	173	855	667	320	215	630	390	147	205	530	245	28	454	
112	979	530	52	56	40	320	320	212	980	795	380	240	645	470	167	180	580	300	35	499	
122	1134	530	52	56	40	390	320	212	1050	795	380	250	800	470	167	265	650	300	35	499	

+) Max ölçülerdir. Ayrıntılara siparişte gönderilen dökümanlardan ulaşılabilir.
Ölçüler mm'dir.

1) **Şaftlar:**
m6<=Ø100; n6>Ø100
Kama kanalı DIN 6885/1,
Kama kanalı genişliği ISO JS9 a göre
Kama DIN 6885/1 form B
Ayrıntılar için sayfa 127-136'ya bakılabilir.

*) Yaklaşık değerlerdir. Kesin verilere siparişte gönderilen dökümanlardan ulaşılabilir.

**) Redüktörler yağsızdır.

+) Max. dimensions; details acc.to order-related documentation.
Dimensions in mm

1) **Shafts:**
m6<=Ø100; n6>Ø100
Keyway acc.to DIN 6885/1,
Hub keyway width acc.to ISO JS9
Parallel key acc.to DIN 6885/1 form B
For details, see pages 127-136

*) Approximate values; exact data acc. to order related documentation.

**) Without oil filling

+) max. Abmessungen; Einzelheiten nach auftragsbezogener Dokumentation.
Abmessungen in mm

1) **Wellen:**
m6<=Ø100; n6>Ø100
Passfedernut nach DIN 6885/1
Nabennutbreite nach ISO JS9
Passfeder nach DIN 6885/1 Form B
Einzelheiten siehe Seiten 127-136

*) Richtwerte; genaue Angaben nach auftragsbezogener Dokumentation.

**) ohne Ölfüllung

TR İKİ KADEMELİ - YATAY

EN TWO STAGE - HORIZONTAL

DE ZWEISTUFIG - HORIZONTAL

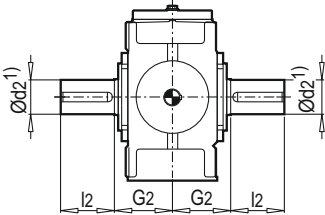
	<p>PB42-SH ... PB122-SH Mil Çıkışlı Solid shaft Vollwelle</p>		Ød2	l2	G2
		42	80	170	170
		52	100	210	200
		62	110	210	200
		72	120	210	235
		82	130	250	235
		92	140	250	270
		102	160	300	270
112	170	300	320		
122	180	300	320		

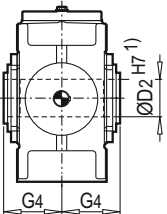
	<p>PB42-HH ... PB122-HH Delik milli Hollow shaft Hohlwelle</p>		ØD2	G4
		42	80	170
		52	95	200
		62	105	200
		72	115	235
		82	125	235
		92	135	270
		102	150	270
112	165	320		
122	180	320		

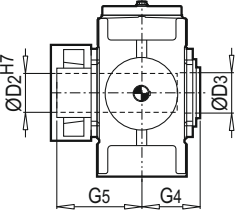
	<p>PB42-DH ... PB122-DH Konik Sıktırmalı Hollow shaft for shrink disk Hohlwelle für schrumpfscheibe</p>		ØD2	ØD3	G4	G5
		42	85	85	170	235
		52	100	100	200	275
		62	110	110	200	275
		72	120	120	235	320
		82	130	130	235	325
		92	140	145	270	365
		102	150	155	270	385
112	165	170	320	450		
122	180	185	320	455		

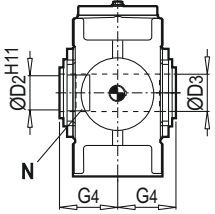
	<p>PB42-KH ... PB122-KH Spline DIN 5480 Hollow shaft with involute splines acc. to DIN 5480 Hohlwelle mit Zahnradprofil nach DIN 5480</p>		N / DIN 5480	ØD2	ØD3	G4
		42	-	-	-	
		52	N 95x3x30x30x9H	89	100	200
		62	N 95x3x30x30x9H	89	110	200
		72	N 120x3x30x38x9H	114	120	235
		82	N 120x3x30x38x9H	114	130	235
		92	N 140x3x30x45x9H	134	145	270
		102	N 140x3x30x45x9H	134	155	270
112	N 170x5x30x32x9H	160	170	320		
122	N 170x5x30x32x9H	160	185	320		

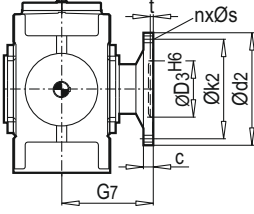
	<p>PB42-FH ... PB122-FH Flanşlı shaft Flanged shaft Flanschswelle</p>		c	Ød2	ØD3	Øk2	nxØs	t	G7
		42	-	-	-	-	-	-	
		52	25	300	150	260	16 x 22	10	290
		62	25	320	160	280	18 x 22	10	290
		72	30	370	180	320	16 x 26	10	340
		82	30	390	190	340	18 x 26	10	340
		92	38	430	220	380	20 x 26	12	385
		102	38	470	240	420	22 x 26	12	385
112	42	510	260	450	18 x 33	12	450		
122	42	540	280	480	22 x 33	12	450		

Gövde Size Größe	Yağ miktarı Oil quantity Ölmenge (l)*	Ağırlık Weight / Gewicht (kg)**	
		SH HH DH KH	FH
42	10	240	-
52	16	365	405
62	19	415	460
72	31	620	675
82	34	710	770
92	48	1010	1100
102	50	1165	1260
112	80	1655	1790
122	95	1930	2080

Soğutma serpantini / Cooling coil / Kühlschlange

Soğutma serpantini su bağlantısı G1/2"
Water connection for cooling coil G1/2"
Wasseranschlus für Kühlschlange G1/2"

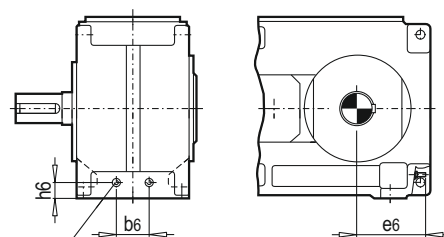

x) Gerekli soğutma suyu miktarı; basıncı 8 bar
Cooling water quantity required, max. cooling water pressure: 8 bar
Erforderliche Kühlwassermenge, max. kühlwasserdruck: 8 bar

Gövde Size Größe	b6	e6	h6	l/min x)
42	90	157	59	4
52	100	169	65	8
62	100	214	65	4
72	100	208	77	8
82	100	266	77	4
92	130	246	75	8
102	130	294	75	8
112	140	275	90	8
122	140	360	90	8

Soğutma sistemi deniz suyu
ve acı su için uygundur
Cooling coil suitable for
fresh, sea and brackish water
Kühlschlange geeignet für
Süß- See- und Brackwasser

TR İKİ KADEMELİ - YATAY

EN TWO STAGE - HORIZONTAL

DE ZWEISTUFIG - HORIZONTAL

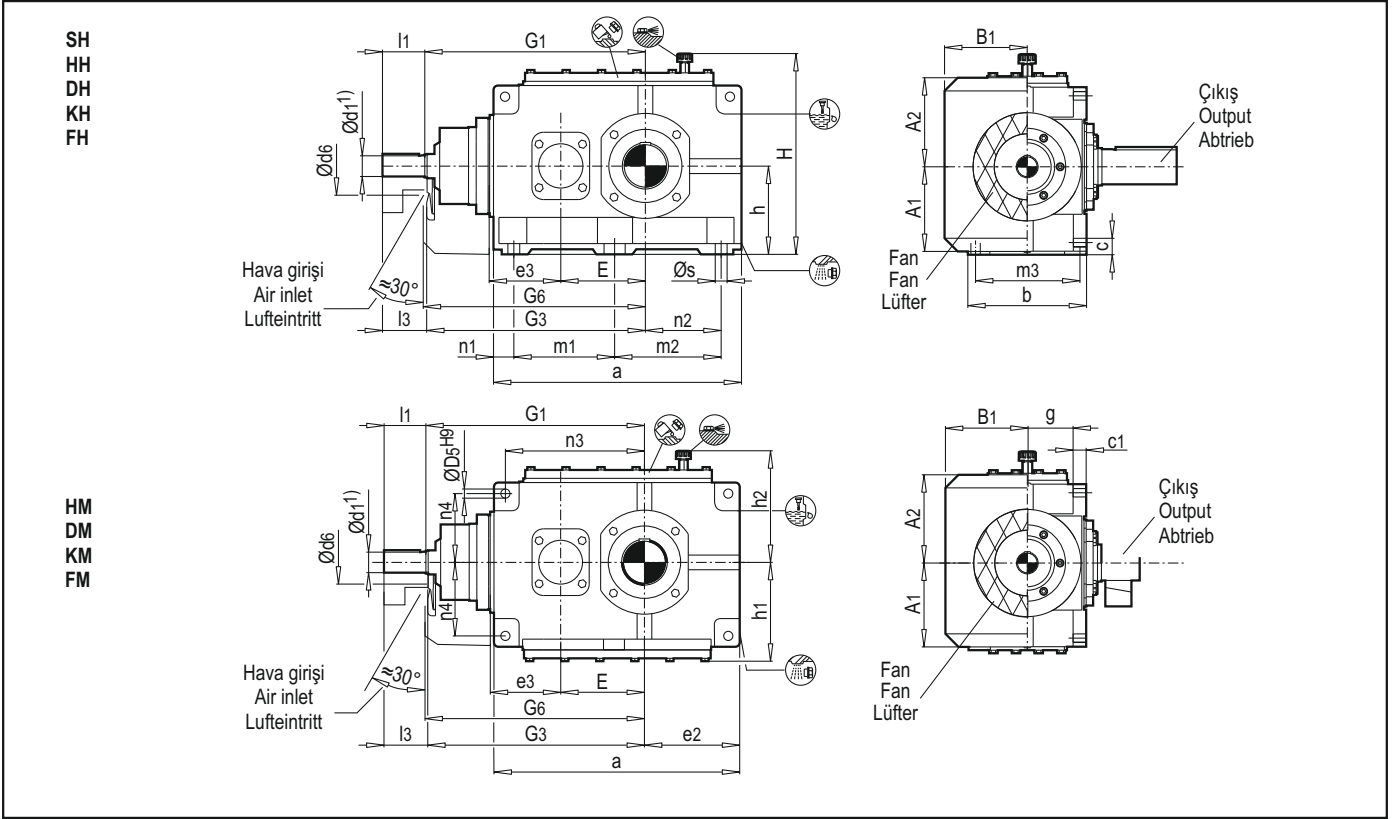

Gövde Size Größe	Giriş / Input / Antrieb															Fan / Fan / Lüfter					
	İN = 5 - 11.2			İN = 5.6 - 11.2			İN = 6.3 - 14			İN = 5.6 - 12.5			İN = 7.1 - 12.5			G1	G3	A1	A2	B1	Ød6
	Ød1	l1	l3	Ød1	l1	l3	Ød1	l1	l3	Ød1	l1	l3	Ød1	l1	l3						
132	110	205	165	-	-	-	-	-	-	-	-	-	-	-	-	1070	1110	432	452	377	245
142	-	-	-	-	-	-	110	205	165	-	-	-	-	-	-	1140	1180	432	452	377	245
152	130	245	200	-	-	-	-	-	-	-	-	-	-	-	-	1277	1322	492	497	437	280
162	-	-	-	-	-	-	-	-	-	130	245	200	-	-	-	1323	1368	492	497	437	280
172	-	-	-	150	245	200	-	-	-	-	-	-	-	-	-	1435	1480	542	557	507	380
182	-	-	-	-	-	-	-	-	-	-	-	-	150	245	200	1495	1540	542	557	507	380

Gövde Size Größe	Redüktörler / Gear Units / Zahnradgetriebe																			Kilit Backstop Rücklaufperre			
	a	b	c	c1	ØD5	E	e2	e3	g	G6	H	h(-1)	h1	h2	m1	m2	m3	n1	n2	n3	n4	Øs	98 G8
132	1134	655	62	63	48	370	407	370	265	1130	905	440	450	460	465	465	580	102	305	675	340	35	561
142	1274	655	62	63	48	440	477	370	265	1200	905	440	450	460	465	605	580	102	375	745	340	35	561
152	1354	765	72	74	55	442	487	442	309	1340	1005	500	490	500	555	555	670	122	365	805	375	42	587
162	1444	765	72	74	55	488	532	442	309	1385	1005	500	490	500	555	645	670	122	410	850	375	42	587
172	1494	885	82	83	65	490	527	490	357	1500	1115	550	555	560	610	610	780	137	390	895	420	48	705
182	1614	885	82	83	65	550	587	490	357	1560	1115	550	555	560	610	730	780	137	450	955	420	48	705

- +) Max ölçülerdir. Ayrıntılara siparişte gönderilen dokümanlardan ulaşılabilir.
Ölçüler mm'dir.
- 1) **Şaftlar:**
n6>Ø100
Kama kanalı DIN 6885/1,
Kama kanalı genişliği ISO JS9 a göre
Kama DIN 6885/1 form B
Ayrıntılar için sayfa 127-136'ya bakılabilir.
- *) Yaklaşık değerlerdir. Kesin verilere siparişte gönderilen dokümanlardan ulaşılabilir.
- **) Redüktörler yağsızdır.

- +) Max. dimensions; details acc.to order-related documentation.
Dimensions in mm
- 1) **Shafts:**
n6>Ø100
Keyway acc.to DIN 6885/1,
Hub keyway width acc.to ISO JS9
Parallel key acc.to DIN 6885/1 form B
For details, see pages 127-136
- *) Approximate values; exact data acc. to order related documentation.
- **) Without oil filling

- +) max. Abmessungen; Einzelheiten nach auftragsbezogener Dokumentation.
Abmessungen in mm
- 1) **Wellen:**
n6>Ø100
Passfedernut nach DIN 6885/1
Nabennutbreite nach ISO JS9
Passfeder nach DIN 6885/1 Form B
Einzelheiten siehe Seiten 127-136
- *) Richtwerte; genaue Angaben nach auftragsbezogener Dokumentation.
- **) ohne Ölfüllung

TR İKİ KADEMELİ - YATAY

EN TWO STAGE - HORIZONTAL

DE ZWEISTUFIG - HORIZONTAL

	<p>PB132- SH ... PB182-SH Mil Çıkışlı Solid shaft Vollwelle</p>		Ød2	l2	G2
		132	200	350	390
		142	210	350	390
		152	230	410	460
		162	240	410	460
		172	250	410	540
182	270	470	540		

	<p>PB132-HH ... PB182-HH PB132-HM ... PB182-HM Delik milli Hollow shaft Hohlwelle</p>		ØD2	G4
		132	-	-
		142	210	390
		152	-	-
		162	240	450
		172	-	-
182	275	510		

	<p>PB132-DH ... PB182-DH PB132-DM ... PB182-DM Konik Sıkırmalı Hollow shaft for shrink disk Hohlwelle für schrumpfscheibe</p>		ØD2	ØD3	G4	G5
		132	-	-	-	-
		142	210	215	390	535
		152	-	-	-	-
		162	240	245	450	620
		172	-	-	-	-
182	280	285	510	700		

	<p>PB132-KH ... PB182-KH PB132-KM ... PB182-KM Spline DIN 5480 Hollow shaft with involute splines acc. to DIN 5480 Hohlwelle mit Zahnablenprofil nach DIN 5480</p>		N / DIN 5480	ØD2	ØD3	G4
		132	-	-	-	-
		142	N 190x5x30x36x9H	180	215	390
		152	-	-	-	-
		162	N 220x5x30x42x9H	210	245	450
		172	-	-	-	-
182	N 250x5x30x48x9H	240	285	510		

	<p>PB132-FH ... PB182-FH PB132-FM ... PB182-FM Flanşlı şaft Flanged shaft Flanschswelle</p>		c	Ød2	ØD3	Øk2	nxØs	t	G7
		132	48	580	310	500	20 x 33	14	525
		142	48	620	310	540	24 x 33	14	525
		152	55	710	360	630	28 x 33	17	625
		162	55	740	360	660	30 x 33	17	625
		172	60	750	410	660	24 x 39	18	695
182	60	800	410	710	26 x 39	18	695		

Gövde Size Größe	Yağ miktarı Oil quantity Ölmenge (l)*)		Ağırlık Weight / Gewicht (kg)*)**)			
	H	M	SH HH DH KH	HM DM KM	FH	FM
132	140	120	2460	2360	2620	2520
142	155	130	2845	2745	3005	2905
152	220	180	4010	3815	4245	4050
162	230	190	4350	4175	4615	4430
172	320	260	5650	5350	5940	5640
182	335	275	6200	5910	6520	6230

Soğutma serpantini Cooling coil /Kühlschlange		Gövde Size Größe	b6	b7	e6	e7	h6	h7	l/min x)
Soğutma serpantini su bağlantısı G1/2" Water connection for cooling coil G1/2" Wasseranschluß für Kühlschlange G1/2"		132	324	324	460	335	116	300	8
		142	324	324	530	405	116	300	8
		152	396	396	540	395	119	335	8
		162	396	396	585	440	119	335	8
		172	468	324	580	425	134	380	8
		182	468	324	640	485	134	380	8

Soğutma serpantini Cooling coil /Kühlschlange		Gövde Size Größe	b6	b7	e6	e7	h6	h7	l/min x)
Soğutma serpantini su bağlantısı G1/2" Water connection for cooling coil G1/2" Wasseranschluß für Kühlschlange G1/2"		132	324	324	460	335	116	300	8
		142	324	324	530	405	116	300	8
		152	396	396	540	395	119	335	8
		162	396	396	585	440	119	335	8
		172	468	324	580	425	134	380	8
		182	468	324	640	485	134	380	8

x) Gereki soğutma suyu miktarı; basıncı 8 bar
Cooling water quantity required, max. cooling water pressure: 8 bar
Erforderliche Kühlwassermenge, max. kühlwasserdruck: 8 bar

Soğutma sistemi deniz suyu ve acı su için uygundur
Cooling coil suitable for fresh, sea and brackish water
Kühlschlange geeignet für Süß- See- und Brackwasser

TR

ÜÇ KADEMELİ - YATAY

EN

THREE STAGE - HORIZONTAL

DE

DREISTUFIG - HORIZONTAL

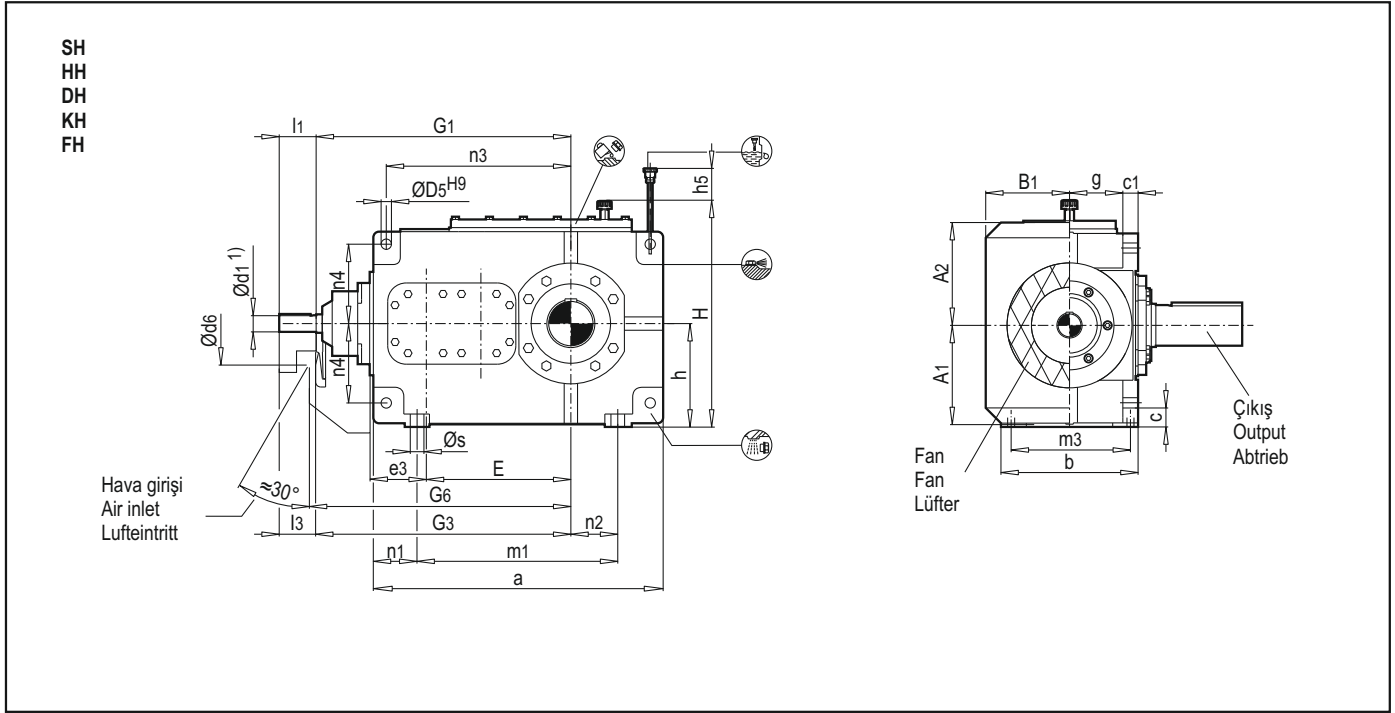

Gövde Size Größe	Giriş / Input / Antrieb												Fan / Fan / Lüfter						
	İN = 12.5 - 45			İN = 50 - 71			İN = 16 - 56			İN = 63 - 90			G1	G3	A1	A2	B1	Ød6	
	Ød1	l1	l3	Ød1	l1	l3	Ød1	l1	l3	Ød1	l1	l3	Ød1	l1	l3				
43	30	70	50	25	60	40	-	-	-	-	-	-	500	520	197	202	145	110	
53	35	80	60	28	60	40	-	-	-	-	-	-	575	595	222	237	170	130	
63	-	-	-	-	-	-	35	80	60	28	60	40	610	630	222	237	170	130	
73	45	100	80	35	80	60	-	-	-	-	-	-	690	710	277	277	195	165	
83	-	-	-	-	-	-	45	100	80	35	80	60	735	755	277	277	195	165	
93	55	110	80	40	100	70	-	-	-	-	-	-	800	830	317	327	233	175	
103	-	-	-	-	-	-	55	110	80	40	100	70	850	880	317	327	233	175	
113	70	135	105	50	110	80	-	-	-	-	-	-	960	990	372	387	265	190	
123	-	-	-	-	-	-	70	135	105	50	110	80	1030	1060	372	387	265	190	

Gövde Size Größe	Redüktörler / Gear Units / Zahnradgetriebe																Kilit Backstop Rücklaufsperre			
	a	b	c	c1	ØD5	E	e3	g	G6	H	h(-1)	h5	m1	m3	n1	n2	n3	n4	Øs	G8
43	569	215	30	31	24	270	110	78	530	420	200	100	355	180	107	85	345	150	19	206
53	644	255	30	31	24	315	130	98	605	487	230	130	430	220	107	100	405	180	19	225
63	724	255	30	31	24	350	130	98	640	487	230	130	510	220	107	145	440	180	19	225
73	789	300	37	37	28	385	160	115	720	577	280	170	545	260	122	130	500	215	24	283
83	894	300	37	37	28	430	160	115	765	587	280	160	650	260	122	190	545	215	24	283
93	929	370	42	47	36	450	185	141	845	667	320	175	635	320	147	155	585	245	28	319
103	1029	370	42	47	36	500	185	141	895	667	320	175	735	320	147	205	635	245	28	319
113	1109	430	52	56	40	545	225	162	1010	787	380	220	775	370	167	180	710	300	35	370
123	1264	430	52	56	40	615	225	162	1080	795	380	210	930	370	167	265	780	300	35	370

+) Max ölçülerdir. Ayrıntılara siparişte gönderilen dökümanlardan ulaşılabilir.

+) Max. dimensions; details acc. to orderrelated documentation.

+) Max. Abmessungen; Einzelheiten nach auftragsbezogener Dokumentation.

Ölçüler mm'dir.

Dimensions in mm

Abmessungen in mm

1) **Şaftlar:**
k6=Ø25; Ø28≤m6≤Ø100; n6>Ø100
Kama kanalı DIN 6885/1,
Kama kanalı genişliği ISO JS9 a göre
Kama DIN 6885/1 form B
Ayrıntılar için sayfa 127-136'ya bakılabilir.

1) **Shafts:**
k6=Ø25; Ø28≤m6≤Ø100; n6>Ø100
Keyway acc.to DIN 6885/1,
Hub keyway width acc.to ISO JS9
Parallel key acc.to DIN 6885/1 form B
For details, see pages 127-136

1) **Wellen:**
k6=Ø25; Ø28≤m6≤Ø100; n6>Ø100
Passfedermut nach DIN 6885/1
Nabennutbreite nach ISO JS9
Passfeder nach DIN 6885/1 Form B
Einzelheiten siehe Seiten 127-136

*) Yaklaşık değerlerdir. Kesin verilere siparişte gönderilen dökümanlardan ulaşılabilir.

*) Approximate values; exact data acc. to order related documentation.

*) Richtwerte; genaue Angaben nach auftragsbezogener Dokumentation.

**) Redüktörler yağsızdır.

**) Without oil filling

**) ohne Ölfüllung

TR ÜÇ KADEMELİ - YATAY

EN THREE STAGE - HORIZONTAL

DE DREISTUFIG - HORIZONTAL

	<p>PB43-SH ... PB123-SH Mil Çıkışlı Solid shaft Vollwelle</p>		Ød2	l2	G2
		43	80	170	140
		53	100	210	165
		63	110	210	165
		73	120	210	195
		83	130	250	195
		93	140	250	235
		103	160	300	235
113	170	300	270		
123	180	300	270		

	<p>PB43-HH ... PB123-HH Delik milli Hollow shaft Hohlwelle</p>		ØD2	G4
		43	80	140
		53	95	165
		63	105	165
		73	115	195
		83	125	195
		93	135	235
		103	150	235
113	165	270		
123	180	270		

	<p>PB43-DH ... PB123-DH Konik Sıkırmalı Hollow shaft for shrink disk Hohlwelle für schrumpfscheibe</p>		ØD2	ØD3	G4	G5
		43	85	85	140	205
		53	100	100	165	240
		63	110	110	165	240
		73	120	120	195	280
		83	130	130	195	285
		93	140	145	235	330
		103	150	155	235	350
113	165	170	270	400		
123	180	185	270	405		

	<p>PB43-KH ... PB123-KH Spline DIN 5480 Hollow shaft with involute splines acc. to DIN 5480 Hohlwelle mit Zahnradprofil nach DIN 5480</p>		N / DIN 5480	ØD2	ØD3	G4
		43	-	-	-	-
		53	N 95x3x30x30x9H	89	100	165
		63	N 95x3x30x30x9H	89	110	165
		73	N 120x3x30x38x9H	114	120	195
		83	N 120x3x30x38x9H	114	130	195
		93	N 140x3x30x45x9H	134	145	235
		103	N 140x3x30x45x9H	134	155	235
113	N 170x5x30x32x9H	160	170	270		
123	N 170x5x30x32x9H	160	185	270		

	<p>PB43-FH ... PB123-FH Flanşlı şaft Flanged shaft Flanschswelle</p>		c	Ød2	ØD3	Øk2	nxØs	t	G7
		43	-	-	-	-	-	-	-
		53	25	300	150	260	16 x 22	10	255
		63	25	320	160	280	18 x 22	10	255
		73	30	370	180	320	16 x 26	10	300
		83	30	390	190	340	18 x 26	10	300
		93	38	430	220	380	20 x 26	12	350
		103	38	470	240	420	22 x 26	12	350
113	42	510	260	450	18 x 33	12	400		
123	42	540	280	480	22 x 33	12	400		

Gövde Size Größe	Yağ miktarı Oil quantity Ölmenge (l) *	Ağırlık Weight / Gewicht (kg) **)		Soğutma serpantini / Cooling coil / Kühlschlange	Gövde Size Größe	b6	e6	h6	l/min x)
		SH HH DH KH	FH						
43	9	215	-	<p>Soğutma serpantini su bağlantısı G1/2" Water connection for cooling coil G1/2" Wasseranschluß für Kühlschlange G1/2"</p> <p>Çıkış Output Abtrieb</p>	43	90	157	59	4
53	15	330	365		53	100	169	65	4
63	16	385	425		63	100	214	65	4
73	27	555	605		73	100	208	77	4
83	30	645	700		83	100	266	77	4
93	42	900	985		93	130	246	75	8
103	46	1030	1120		103	130	294	75	8
113	73	1470	1600		113	140	275	90	8
123	84	1745	1885		123	140	360	90	8

x) Gereklİ soğutma suyu miktarı; basıncı 8 bar
Cooling water quantity required,
max. cooling water pressure: 8 bar
Erforderliche Kühlwassermenge,
max. kühlwasserdruck: 8 bar

Soğutma sistemi deniz suyu ve acı su için uygundur
Cooling coil suitable for fresh, sea and brackish water
Kühlschlange geeignet für Süß- See- und Brackwasser

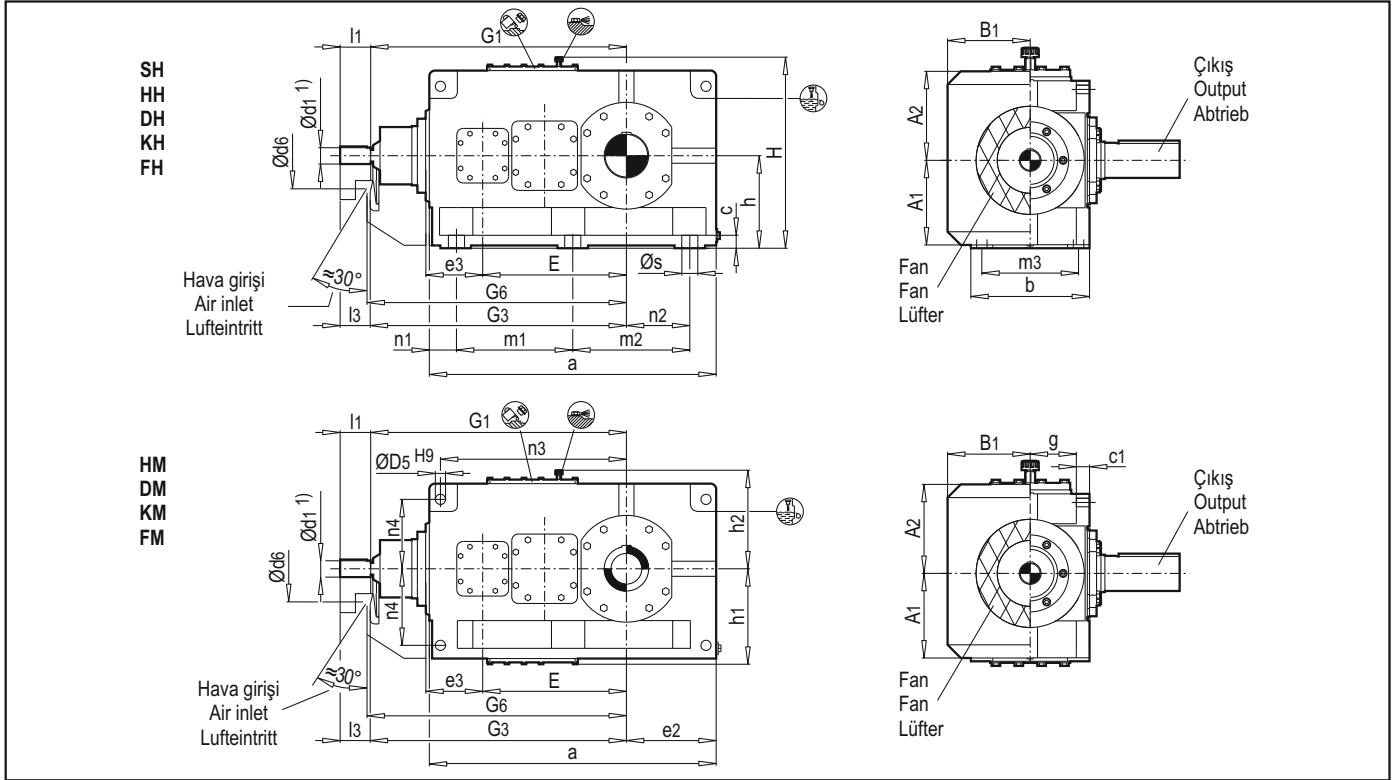

Gövde Size Größe	Giriş / Input / Antrieb																		Fan / Fan / Lüfter								
	iN = 12.5 - 45			iN = 50 - 71			iN = 14 - 50			iN = 56 - 80			iN = 16 - 56			iN = 63 - 90			G1	G3	A1	A2	B1	Ød6			
	Ød1	l1	l3	Ød1	l1	l3	Ød1	l1	l3	Ød1	l1	l3	Ød1	l1	l3	Ød1	l1	l3	Ød1	l1	l3						
133	80	165	130	60	140	105	-	-	-	-	-	-	-	-	-	-	-	-	-	-	-	1125	1160	427	437	327	210
143	-	-	-	-	-	-	-	-	-	-	-	-	-	-	-	80	165	130	60	140	105	1195	1230	427	437	327	210
153	90	165	130	70	140	105	-	-	-	-	-	-	-	-	-	-	-	-	-	-	-	1367	1402	487	522	367	210
163	-	-	-	-	-	-	90	165	130	70	140	105	-	-	-	-	-	-	-	-	-	1413	1448	487	522	367	210
173	110	205	165	80	170	130	-	-	-	-	-	-	-	-	-	-	-	-	-	-	-	1560	1600	537	572	397	230
183	-	-	-	-	-	-	110	205	165	80	170	130	-	-	-	-	-	-	-	-	-	1620	1660	537	572	397	230
193	130	245	200	100	210	165	-	-	-	-	-	-	-	-	-	-	-	-	-	-	-	1832	1877	612	632	450	245
203	-	-	-	-	-	-	130	245	200	100	210	165	-	-	-	-	-	-	-	-	-	1892	1937	612	632	450	245
213	130	245	200	100	210	165	-	-	-	-	-	-	-	-	-	-	-	-	-	-	-	1902	1947	692	692	475	280
223	-	-	-	-	-	-	130	245	200	100	210	165	-	-	-	-	-	-	-	-	-	1957	2002	692	692	475	280

Gövde Size Größe	Redüktörler / Gear Units / Zahnradgetriebe																				Kilit Backstop Rücklaufsperre			
	a	b	c	c1	ØD5	E	e2	e3	g	G6	H	h(-1)	h1	h2	m1	m2	m3	n1	n2	n3	n4	Øs	98	G8
133	1294	550	62	63	48	635	407	265	212	1180	905	440	450	460	545	545	475	102	305	835	340	35		453
143	1434	550	62	63	48	705	477	265	212	1250	905	440	450	460	545	685	475	102	375	905	340	35		453
153	1554	625	72	74	55	762	487	320	239	1420	1005	500	490	500	655	655	535	122	365	1005	375	42		499
163	1644	625	72	74	55	808	532	320	239	1470	1005	500	490	500	655	745	535	122	410	1050	375	42		499
173	1744	690	82	83	55	860	527	370	260	1620	1115	550	555	560	735	735	600	137	390	1145	425	42		566
183	1864	690	82	83	55	920	587	370	260	1680	1115	550	555	560	735	855	600	137	450	1205	425	42		566
193	2014	790	92	93	65	997	592	420	300	1900	1245	620	615	620	850	850	690	157	435	1345	475	48		623
203	2134	790	92	93	65	1057	652	420	300	1960	1245	620	615	620	850	970	690	157	495	1405	475	48		623
213	2144	830	102	102	75	1067	657	450	311	1970	1395	700	685	690	900	900	720	172	485	1400	520	56		642
223	2254	830	102	102	75	1122	712	450	311	2025	1395	700	685	690	900	1010	720	172	540	1455	520	56		642

- +) Max ölçülerdir. Ayrıntılara siparişte gönderilen dokümanlardan ulaşılabilir. Ölçüler mm'dir. +) Max.dimensions; details acc. to order-related documentation +) Max. Abmessungen; Einzelheiten nach auftragsbezogener Dokumentation. Abmessungen in mm
- 1) Şaftlar: m6<=Ø100; n6>Ø100
Kama kanalı DIN 6885/1,
Kama kanalı genişliği ISO JS9 a göre
Kama DIN 6885/1 form B
Ayrıntılar için sayfa 127-136'ya bakılabilir. 1) Wellen: m6<=Ø100; n6>Ø100
Passfedernut nach DIN 6885/1
Nabennutbreite nach ISO JS9
Passfeder nach DIN 6885/1 Form B
Einzelheiten siehe Seiten 127-136
- *) Yaklaşık değerlerdir. Kesin verilere siparişte gönderilen dokümanlardan ulaşılabilir. *) Approximate values; exact data acc. to order related documentation. *) Richtwerte; genaue Angaben nach auftragsbezogener Dokumentation.
- ***) Redüktörler yağsızdır. **) Without oil filling

TR ÜÇ KADEMELİ - YATAY

EN THREE STAGE - HORIZONTAL

DE DREISTUFIG - HORIZONTAL

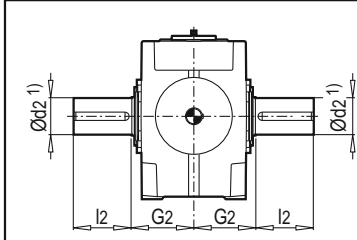

PB133-SH ... PB223-SH
Mil Çıkışı
Solid shaft
Vollwelle

	Ød2	l2	G2
133	200	350	335
143	210	350	335
153	230	410	380
163	240	410	380
173	250	410	415
183	270	470	415
193	290	470	465
203	300	500	465
213	320	500	490
223	340	550	490

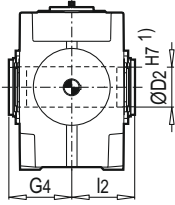

PB133-HH ... PB223-HH
PB133-HM ... PB223-HM
Delik milli
Hollow shaft
Hohlwelle

	ØD2	G4
133	190	335
143	210	335
153	230	380
163	240	380
173	250	415
183	275	415
193	-	-
203	-	-
213	-	-
223	-	-

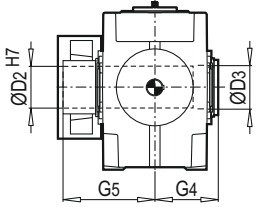

PB133-DH ... PB223-DH
PB133-DM ... PB223-DM
Konik Sıktırma
Hollow shaft for shrink disk
Hohlwelle für schrumpfscheibe

	ØD2	ØD3	G4	G5
133	190	195	335	480
143	210	215	335	480
153	230	235	380	550
163	240	245	380	550
173	250	260	415	600
183	280	285	415	600
193	285	295	465	670
203	310	315	465	670
213	330	335	490	715
223	340	345	490	725

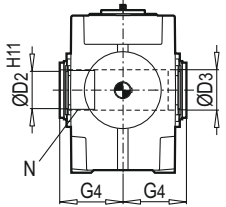

PB133-KH ... PB223-KH
PB133-KM ... PB223-KM
Spline DIN 5480
Hollow shaft with involute splines acc. to DIN 5480
Hohlwelle mit Zahnradprofil nach DIN 5480

	N / DIN 5480	ØD2	ØD3	G4
133	N 190x5x30x36x9H	180	195	335
143	N 190x5x30x36x9H	180	215	335
153	N 220x5x30x42x9H	210	235	380
163	N 220x5x30x42x9H	210	245	380
173	N 250x5x30x48x9H	240	260	415
183	N 250x5x30x48x9H	240	285	415
193				
203				
213				
223				

İstek üzerine
On request
Auf Anfrage

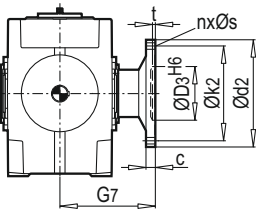

PB133-FH ... PB223-FH
PB133-FM ... PB223-FM
Flanşlı şaft
Flanged shaft
Flanschelle

	c	Ød2	ØD3	Øk2	nxØs	t	G7
133	48	580	310	500	20 x 33	14	480
143	48	620	310	540	24 x 33	14	480
153	55	710	360	630	28 x 33	17	550
163	55	740	360	660	30 x 33	17	550
173	60	750	410	660	24 x 39	18	600
183	60	800	410	710	26 x 39	18	600
193	65	860	460	770	30 x 39	18	670
203	65	930	460	830	32 x 39	18	670
213	75	950	520	850	28 x 45	20	710
223	75	1040	520	940	28 x 45	20	710

Gövde Size Größe	Yağ miktarı Oil quantity Ölmenge (l)*		Ağırlık / Weight / Gewicht (kg)**)**			
	H	M	SH HH DH KH	HM DM KM	FH	FM
133	130	110	2400	2280	2560	2440
143	140	115	2770	2635	2940	2805
153	210	160	3760	3570	4000	3810
163	220	165	4025	3795	4280	4050
173	290	230	5025	4795	5325	5095
183	300	235	5530	5275	6080	5625
193	380	360	7040	6540		
203	440	420	8150	7650		
213	370	420	9250	8650		
223	430	490	9990	9490		

Soğutma serpantini / Cooling coil / Kùhlschlange

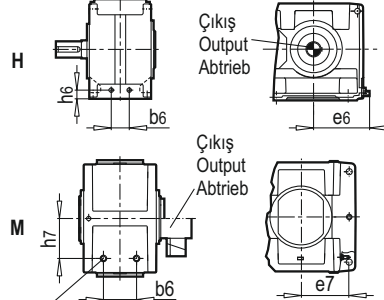

Gövde Size Größe	b6	e6	e7	h6	h7	l/min x)
133	252	455	335	116	300	8
143	252	525	405	116	300	8
153	290	535	395	119	335	8
163	290	580	440	119	335	8
173	340	575	425	134	380	8
183	340	635	485	134	380	8
193						
203						
213						
223						

x) Gereklı soğutma suyu miktarı; basıncı 8 bar
Cooling water quantity required,
max. cooling water pressure: 8 bar
Erforderliche Kühlwassermenge,
max. kühlwasserdruck: 8 bar

Soğutma serpantini su bağlantısı G1/2"
Water connection for cooling coil G1/2"
Wasseranschluß für Kùhlschlange G1/2"

Soğutma sistemi deniz suyu ve acı su için uygundur
Cooling coil suitable for fresh, sea and brackish water
Kùhlschlange geeignet für Süß- See- und Brackwasser

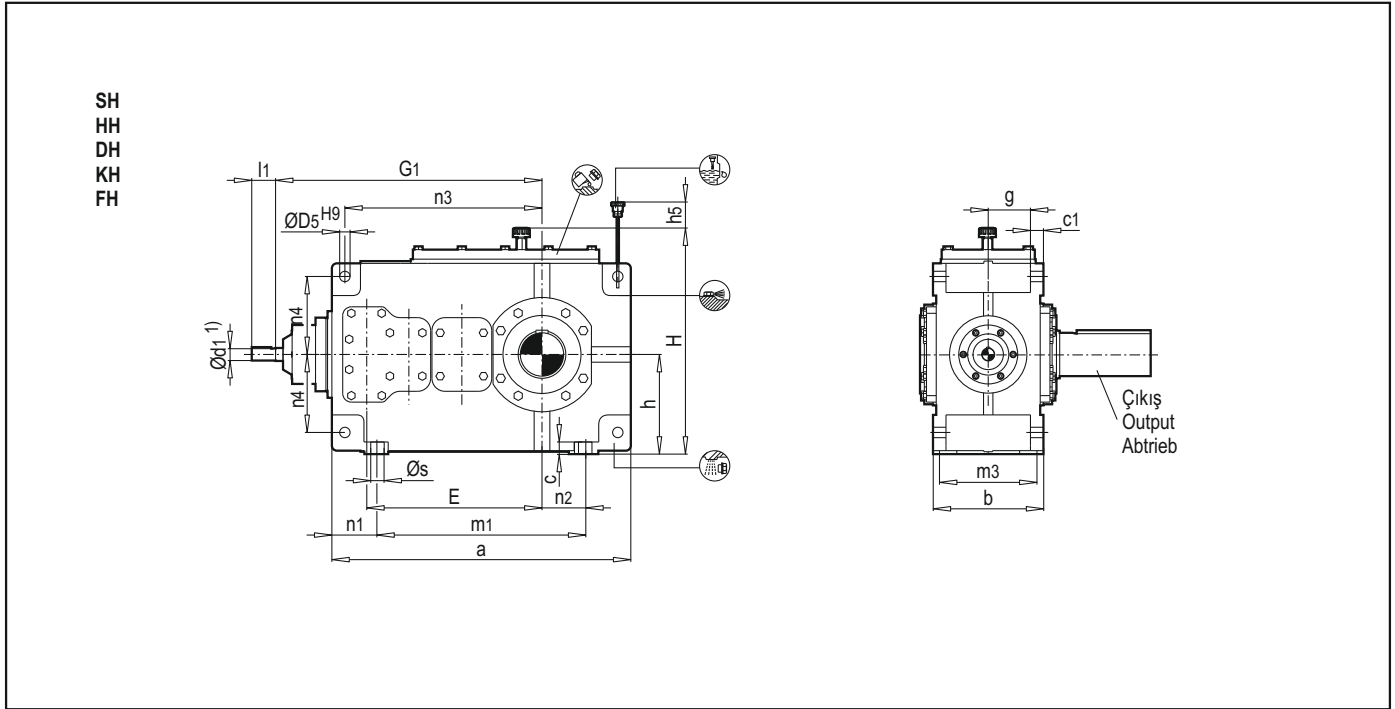

Gövde Size Größe	Giriş / Input / Antrieb								G1
	İN = 80 - 180		İN = 200 - 315		İN = 100 - 224		İN = 250 - 400		
	Ød1	l1	Ød1	l1	Ød1	l1	Ød1	l1	
54	28	55	20	50	-	-	-	-	615
64	-	-	-	-	28	55	20	50	650
74	30	70	25	60	-	-	-	-	725
84	-	-	-	-	30	70	25	60	770
94	35	80	28	60	-	-	-	-	840
104	-	-	-	-	35	80	28	60	890
114	45	100	35	80	-	-	-	-	1010
124	-	-	-	-	45	100	35	80	1080

Gövde Size Größe	Redüktörler / Gear Units / Zahnradgetriebe															Kilit Backstop Rücklaufsperre 98 G8		
	a	b	c	c1	ØD5	E	g	H	h(-1)	h5	m1	m3	n1	n2	n3		n4	Øs
54	694	255	30	31	24	405	98	487	230	100	480	220	107	100	455	180	19	238
64	774	255	30	31	24	440	98	487	230	100	560	220	107	145	490	180	19	238
74	849	300	37	37	28	495	115	577	280	140	605	260	122	130	560	215	24	288
84	954	300	37	37	28	540	115	587	280	130	710	260	122	190	605	215	24	288
94	1004	370	42	47	36	580	141	667	320	135	710	320	147	155	660	245	28	319
104	1104	370	42	47	36	630	141	667	320	135	810	320	147	205	710	245	28	319
114	1204	430	52	56	40	705	162	787	380	170	870	370	167	180	805	300	35	335
124	1359	430	52	56	40	775	162	795	380	160	1025	370	167	265	875	300	35	335

+) Max ölçülerdir. Ayrıntılara siparişte gönderilen dokümanlardan ulaşılabilir.

Ölçüler mm'dir.

1) Şaftlar:

k6=Ø25; Ø28≤m6≤Ø100; n6>Ø100

Kama kanalı DIN 6885/1,

Kama kanalı genişliği ISO JS9 a göre

Kama DIN 6885/1 form B

Ayrıntılar için sayfa 127-136'ya bakılabilir.

*) Yaklaşık değerlerdir. Kesin verilere siparişte gönderilen dokümanlardan ulaşılabilir.

***) Redüktörler yağsızdır.

+) Max. dimensions; details acc. to orderrelated documentation

Dimensions in mm

1) Shafts:

k6=Ø25; Ø28≤m6≤Ø100; n6>Ø100

Keyway acc.to DIN 6885/1,

Hub keyway width acc.to ISO JS9

Parallel key acc.to DIN 6885/1 form B

For details, see pages 127-136

*) Approximate values; exact data acc. to order related documentation.

***) Without oil filling

+) Max. Abmessungen; Einzelheiten nach auftragsbezogener Dokumentation.

Abmessungen in mm

1) Wellen:

k6=Ø25; Ø28≤m6≤Ø100; n6>Ø100

Passfedernut nach DIN 6885/1

Nabennutbreite nach ISO JS9

Passfeder nach DIN 6885/1 Form B

Einzelheiten siehe Seiten 127-136

*) Richtwerte; genaue Angaben nach auftragsbezogener Dokumentation.

***) ohne Ölfüllung

TR DÖRT KADEMELİ - YATAY

EN FOUR STAGE - HORIZONTAL

DE VIERSTUFIG - HORIZONTAL

	<p>PB54-SH ... PB124-SH Mil Çıkışlı Solid shaft Vollwelle</p>		Ød2	l2	G2
		54	100	210	165
		64	110	210	165
		74	120	210	195
		84	130	250	195
		94	140	250	235
		104	160	300	235
		114	170	300	270
124	180	300	270		

	<p>PB54-HH ... PB124-HH Delik milli Hollow shaft Hohlwelle</p>		ØD2	G4
		54	95	165
		64	105	165
		74	115	195
		84	125	195
		94	135	235
		104	150	235
		114	165	270
124	180	270		

	<p>PB54-DH ... PB124-DH Konik Sıkırmalı Hollow shaft for shrink disk Hohlwelle für schrumpfscheibe</p>		ØD2	ØD3	G4	G5
		54	100	100	165	240
		64	110	110	165	240
		74	120	120	195	280
		84	130	130	195	285
		94	140	145	235	330
		104	150	155	235	350
		114	165	170	270	400
124	180	185	270	405		

	<p>PB54-KH ... PB124-KH Spline DIN 5480 Hollow shaft with involute splines acc. to DIN 5480 Hohlwelle mit Zahnablenprofil nach DIN 5480</p>		N / DIN 5480		ØD2	ØD3	G4
		54	N 95x3x30x30x9H		89	100	165
		64	N 95x3x30x30x9H		89	110	165
		74	N 120x3x30x38x9H		114	120	195
		84	N 120x3x30x38x9H		114	130	195
		94	N 140x3x30x45x9H		134	145	235
		104	N 140x3x30x45x9H		134	155	235
		114	N 170x5x30x32x9H		160	170	270
124	N 170x5x30x32x9H		160	185	270		

	<p>PB54-FH ... PB124-FH Flanşlı shaft Flanged shaft Flanschelle</p>		c	Ød2	ØD3	Øk2	nxØs	t	G7
		54	25	300	150	260	16 x 22	10	255
		64	25	320	160	280	18 x 22	10	255
		74	30	370	180	320	16 x 26	10	300
		84	30	390	190	340	18 x 26	10	300
		94	38	430	220	380	20 x 26	12	350
		104	38	470	240	420	22 x 26	12	350
		114	42	510	260	450	18 x 33	12	400
124	42	540	280	480	22 x 33	12	400		

Gövde Size Größe	Yağ miktarı Oil quantity Ölmenge (l)*	Ağırlık / Weight Gewicht (kg)****)	
		SH HH DH KH	FH
54	16	340	375
64	18	390	430
74	30	560	610
84	33	670	725
94	48	905	990
104	50	1040	1130
114	80	1505	1640
124	90	1770	1910

TR DÖRT KADEMELİ - YATAY

EN FOUR STAGE - HORIZONTAL

DE VIERSTUFIG - HORIZONTAL

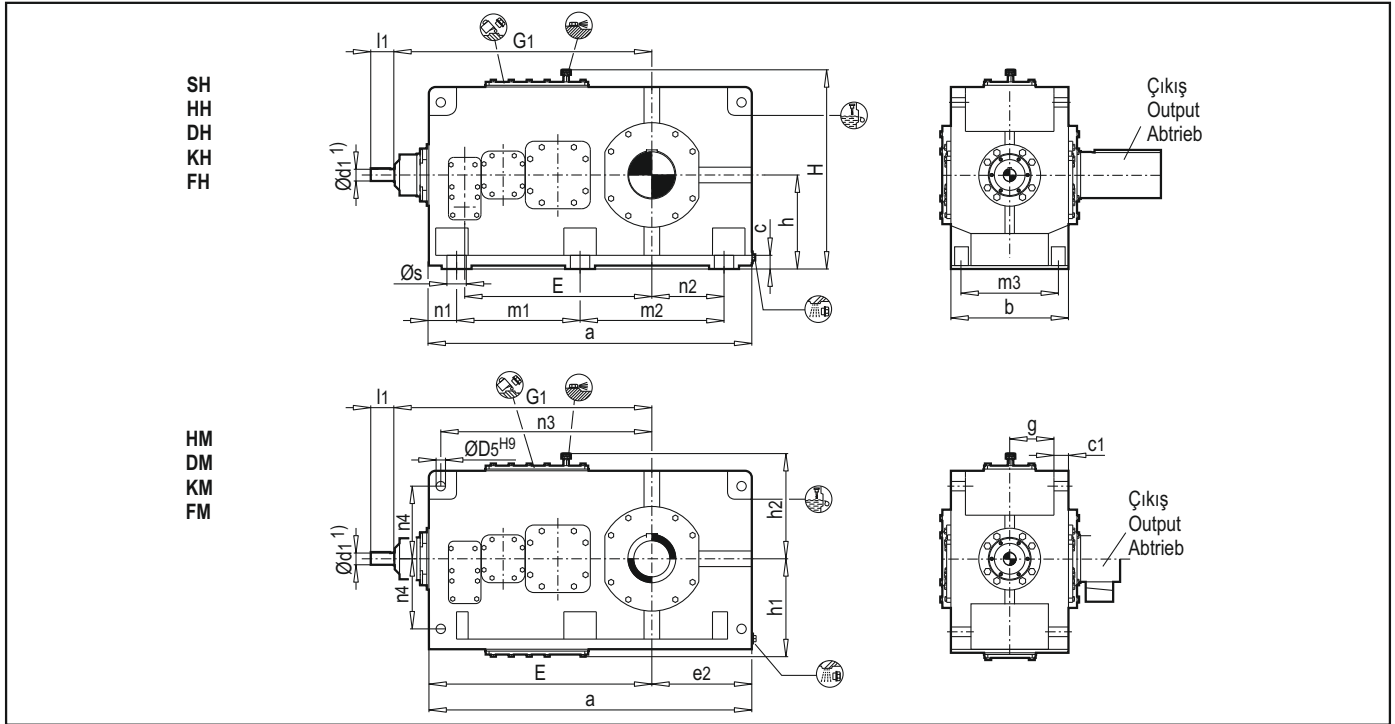

Gövde Size Größe	Giriş / Input / Antrieb												G1
	İN = 80 - 180		İN = 200 - 315		İN = 90 - 200		İN = 224 - 355		İN = 100 - 224		İN = 250 - 400		
	Ød1	l1	Ød1	l1	Ød1	l1	Ød1	l1	Ød1	l1	Ød1	l1	
134	55	110	40	100	-	-	-	-	-	-	-	-	1170
144	-	-	-	-	-	-	-	-	55	110	40	100	1240
154	70	135	50	110	-	-	-	-	-	-	-	-	1402
164	-	-	-	-	70	135	50	110	-	-	-	-	1448
174	70	135	50	110	-	-	-	-	-	-	-	-	1450
184	-	-	-	-	70	135	50	110	-	-	-	-	1510
194	80	165	60	140	-	-	-	-	-	-	-	-	1680
204	-	-	-	-	80	165	60	140	-	-	-	-	1740
214	90	165	70	140	-	-	-	-	-	-	-	-	1992
224	-	-	-	-	90	165	70	140	-	-	-	-	2047

Gövde Size Größe	Redüktörler / Gear Units / Zahnradgetriebe																Kilit Backstop Rücklaufsperre					
	a	b	c	c1	ØD5	E	e2	g	H	h(-1)	h1	h2	m1	m2	m3	n1	n2	n3	n4	Øs	98	G8
134	1399	550	62	63	48	820	407	212	905	440	450	460	597.5	597.5	475	102	305	940	340	35		393
144	1539	550	62	63	48	890	477	212	905	440	450	460	597.5	737.5	475	102	375	1010	340	35		393
154	1684	625	72	74	55	987	487	239	1005	500	490	500	720	720	535	122	365	1135	375	42		489
164	1774	625	72	74	55	1033	532	239	1005	500	490	500	720	810	535	122	410	1180	375	42		489
174	1774	690	82	83	55	1035	527	260	1115	550	555	560	750	750	600	137	390	1175	425	42		489
184	1894	690	82	83	55	1095	587	260	1115	550	555	560	750	870	600	137	450	1235	425	42		489
194	2034	790	92	93	65	1190	592	300	1245	620	615	620	860	860	690	157	435	1365	475	48		563
204	2154	790	92	93	65	1250	652	300	1245	620	615	620	860	980	690	157	495	1425	475	48		563
214	2344	830	102	102	75	1387	657	311	1395	700	685	690	1000	1000	720	172	485	1600	520	56		582
224	2454	830	102	102	75	1442	712	311	1395	700	685	690	1000	1110	720	172	540	1655	520	56		582

+) Max ölçülerdir. Ayrıntılara siparişte gönderilen dökümanlardan ulaşılabilir.
Ölçüler mm'dir.

1) **Şaftlar:**
k6=Ø25; Ø28≤m6≤Ø100; n6>Ø100
Kama kanalı DIN 6885/1,
Kama kanalı genişliği ISO JS9 a göre
Kama DIN 6885/1 form B
Ayrıntılar için sayfa 127-136'ya bakılabilir.

*) Yaklaşık değerlerdir. Kesin verilere siparişte gönderilen dökümanlardan ulaşılabilir.

**) Redüktörler yağsızdır.

+) Max. dimensions; details acc. to order-related documentation

Dimensions in mm

1) **Shafts:**
m6<=Ø100; n6>Ø100
Keyway acc.to DIN 6885/1,
Hub keyway width acc.to ISO JS9
Parallel key acc.to DIN 6885/1 form B
For details, see pages 127-136

*) Approximate values; exact data acc. to order related documentation.

**) Without oil filling

+) Max. Abmessungen; Einzelheiten nach auftragsbezogener Dokumentation.

Abmessungen in mm

1) **Wellen:**
m6<=Ø100; n6>Ø100
Passfedernut nach DIN 6885/1
Nabennutbreite nach ISO JS9
Passfeder nach DIN 6885/1 Form B
Einzelheiten siehe Seiten 127-136

*) Richtwerte; genaue Angaben nach auftragsbezogener Dokumentation.

**) ohne Ölfüllung

TR DÖRT KADEMELİ - YATAY

EN FOUR STAGE - HORIZONTAL

DE VIERSTUFIG - HORIZONTAL

	<p>PB134-SH ... PB224-SH Mil Çıkışlı Solid shaft Vollwelle</p>		Ød2	l2	G2
		134	200	350	335
		144	210	350	335
		154	230	410	380
		164	240	410	380
		174	250	410	415
		184	270	470	415
		194	290	470	465
		204	300	500	465
		214	320	500	490
224	340	550	490		

	<p>PB134-HH ... PB224-HH Delik milli Hollow shaft Hohlwelle</p>		ØD2	G4
		134	190	335
		144	210	335
		154	230	380
		164	240	380
		174	250	415
		184	275	415
		194	-	-
		204	-	-
		214	-	-
224	-	-		

	<p>PB134-DH ... PB224-DH PB134-DM ... PB224-DM Konik Sıkırmalı Hollow shaft for shrink disk Hohlwelle für schrumpfscheibe</p>		ØD2	ØD3	G4	G5
		134	190	195	335	480
		144	210	215	335	480
		154	230	235	380	550
		164	240	245	380	550
		174	250	260	415	600
		184	280	285	415	600
		194	285	295	465	670
		204	310	315	465	670
		214	330	335	490	715
224	340	345	490	725		

	<p>PB134-KH ... PB224-KH PB134-KM ... PB224-KM Spline DIN 5480 Hollow shaft with involute splines acc. to DIN 5480 Hohlwelle mit Zahnradprofil nach DIN 5480</p>		N / DIN 5480	ØD2	ØD3	G4
		134	N 190x5x30x36x9H	180	195	335
		144	N 190x5x30x36x9H	180	215	335
		154	N 220x5x30x42x9H	210	235	380
		164	N 220x5x30x42x9H	210	245	380
		174	N 250x5x30x48x9H	240	260	415
		184	N 250x5x30x48x9H	240	285	415
		194				
		204				
		214				
224						

	<p>PB134-FH ... PB224-FH PB134-FM ... PB224-FM Flanşlı şaft Flanged shaft Flanschelle</p>		c	Ød2	ØD3	Øk2	nxØs	t	G7
		134	48	580	310	500	20 x 33	14	480
		144	48	620	310	540	24 x 33	14	480
		154	55	710	360	630	28 x 33	17	550
		164	55	740	360	660	30 x 33	17	550
		174	60	750	410	660	24 x 39	18	600
		184	60	800	410	710	26 x 39	18	600
		194	65	860	460	770	30 x 39	18	670
		204	65	930	460	830	32 x 39	18	670
		214	75	950	520	850	28 x 45	20	710
224	75	1040	520	940	28 x 45	20	710		

Gövde Size Größe	Yağ miktarı Oil quantity Ölmenge (l *)		Ağırlık Weight / Gewicht (kg)**)			
	H	M	SH HH DH KH	HM DM KM	FH	FM
134	145	120	2410	2295	2570	2455
144	150	125	2750	2620	2920	2790
154	230	170	3650	3455	3890	3695
164	235	175	4005	3785	4260	4040
174	295	230	4720	4485	5020	4785
184	305	235	5030	4960	5580	5310
194	480	440	6850	6350		
204	550	510	8250	7750		
214	540	590	9260	8660		
224	620	680	9990	9490		

İstek üzerine
On request
Auf Anfrage

KONİK - HELİSEL DİŞLİLİ REDÜKTÖRLER / BEVEL - HELICAL GEAR UNITS / KEGELSTIRNRADGETRIEBE

İki kademe, Yatay / Double stage, Horizontal / Zweistufig, Horizontal - PB42-H ... 122-H																				
						<p>Kilit uygulaması mümkün değildir Backstop not possible for Rücklaufsperrenanbau nicht möglich für SH Dizayn / Design / Ausführung A,C,E+F FH Dizayn / Design / Ausführung A+C DH Dizayn / Design / Ausführung B+D</p>														
İki kademe, Yatay / Double stage, Horizontal / Zweistufig, Horizontal - PB132-H ... 182-H / PB132-M ... 182-M																				
						<p>Kilit uygulaması mümkün değildir Backstop not possible for Rücklaufsperrenanbau nicht möglich für</p> <table border="0"> <thead> <tr> <th>Dizayn / Design Ausführung</th> <th>Boyutlar / Sizes Größen</th> </tr> </thead> <tbody> <tr> <td>SH A-C-E-F</td> <td>→ 132 - 142</td> </tr> <tr> <td>SH B-D-E-F</td> <td>→ 152 - 182</td> </tr> <tr> <td>FH A-C</td> <td>→ 132 - 142</td> </tr> <tr> <td>FH B-D</td> <td>→ 152 - 182</td> </tr> <tr> <td>DH B-D</td> <td>→ 142</td> </tr> <tr> <td>DH A-C</td> <td>→ 162 - 182</td> </tr> </tbody> </table> <p> <input checked="" type="checkbox"/> Kilit: Gövde 132-142 Backstop: Sizes 132-142 Rücklaufsperrre: Größen 132-142 <input type="checkbox"/> Kilit: Gövde 152-182 Backstop: Sizes 152-182 Rücklaufsperrre: Größen 152-182 </p>	Dizayn / Design Ausführung	Boyutlar / Sizes Größen	SH A-C-E-F	→ 132 - 142	SH B-D-E-F	→ 152 - 182	FH A-C	→ 132 - 142	FH B-D	→ 152 - 182	DH B-D	→ 142	DH A-C	→ 162 - 182
Dizayn / Design Ausführung	Boyutlar / Sizes Größen																			
SH A-C-E-F	→ 132 - 142																			
SH B-D-E-F	→ 152 - 182																			
FH A-C	→ 132 - 142																			
FH B-D	→ 152 - 182																			
DH B-D	→ 142																			
DH A-C	→ 162 - 182																			
Üç kademe, Yatay / Three stage, Horizontal / Dreistufig, Horizontal - PB43-H ... 123-H																				
Üç kademe, Yatay / Three stage, Horizontal / Dreistufig, Horizontal - PB133-H ... 223-H / PB133-M ... 223-M																				
						<p> <input checked="" type="checkbox"/> Kilit: Gövde 133-183 Backstop: Sizes 133-183 Rücklaufsperrre: Größen 133-183 <input type="checkbox"/> Kilit: Gövde 193-223 Backstop: Sizes 193-223 Rücklaufsperrre: Größen 193-223 </p>														
Dört kademe, Yatay / Four stage, Horizontal / Vierstufig, Horizontal - PB54-H ... 124-H																				
						<p> <input checked="" type="checkbox"/> Kilit: Gövde 54-104 Backstop: Sizes 54-104 Rücklaufsperrre: Größen 54-104 <input type="checkbox"/> Kilit: Gövde 114-124 Backstop: Sizes 114-124 Rücklaufsperrre: Größen 114-124 </p>														
Dört kademe, Yatay / Four stage, Horizontal / Vierstufig, Horizontal - PB134-H ... 224-H / PB134-M ... 224-H																				
<p><input checked="" type="checkbox"/> Kilit / Backstop / Rücklaufsperrre</p>																				

Ölçü Tabloları

Dimension Tables

Größe Tabellen

PH...

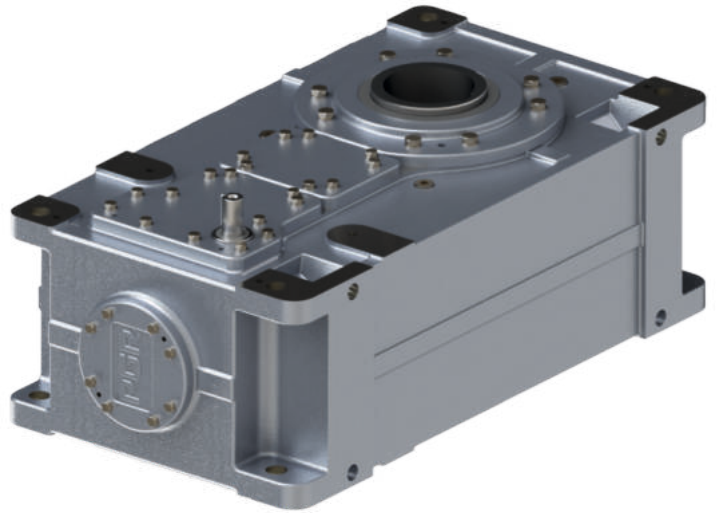

İKİ KADEME / DOUBLE STAGE / ZWEISTUFIG

ÜÇ KADEME / THREE STAGE / DREISTUFIG

DÖRT KADEME / FOUR STAGE / VIERSTUFIG

PH SERİSİ / DİKEY
PH SERIES / VERTICAL
PH SERIE / VERTIKAL

TR

İKİ KADEMELİ - DİKEY

EN

TWO STAGE - VERTICAL

DE

ZWEISTUFIG - VERTIKAL

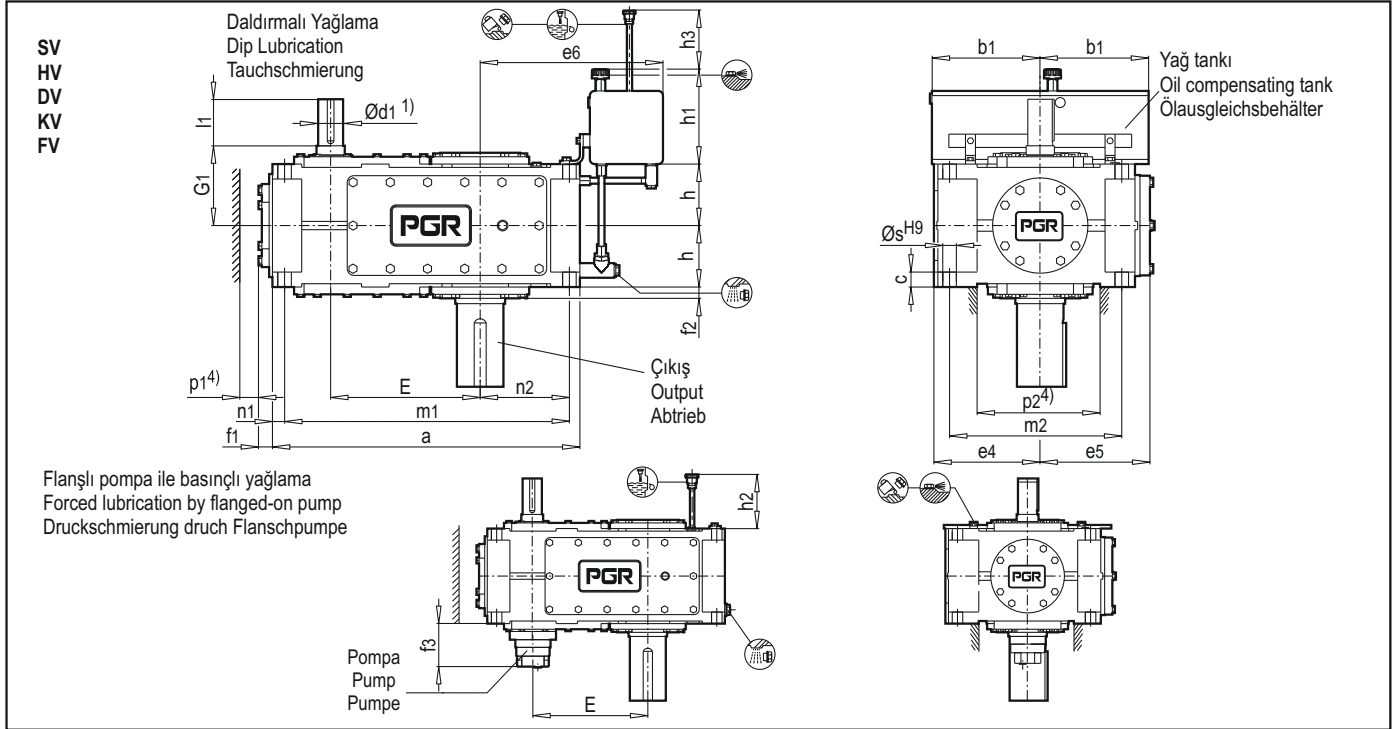

Gövde Size Größe	Giriş / Input / Antrieb												Sadece G,H,I dizaynı için; I_N Design G,H,I only for; I_N Ausführung G,H,I nur für I_N	
	$I_N = 6.3 - 11.2$			$I_N = 12.5 - 22.4$			$I_N = 8 - 14$			$I_N = 16 - 28$				G1
	$\varnothing d1$	$l1$	$l3$	$\varnothing d1$	$l1$	$l3$	$\varnothing d1$	$l1$	$l3$	$\varnothing d1$	$l1$	$l3$		
42	45	100	80	32	80	60	-	-	-	-	-	-	170	6.3 - 18
52	50	100	80	38	80	60	-	-	-	-	-	-	195	6.3 - 18
62	-	-	-	-	-	-	50	100	80	38	80	60	195	8 - 22.4
72	60	135	105	50	110	80	-	-	-	-	-	-	210	6.3 - 16
82	-	-	-	-	-	-	60	135	105	50	110	80	210	8 - 20
92	75	140	110	60	140	110	-	-	-	-	-	-	240	6.3 - 16
102	-	-	-	-	-	-	75	140	110	60	140	110	240	8 - 20
112	90	165	130	70	140	105	-	-	-	-	-	-	275	6.3 - 18
122	-	-	-	-	-	-	90	165	130	70	140	105	275	8 - 22.4

Gövde Size Größe	Redüktörler / Gear Units / Zahnradgetriebe																				
	a	b1	c	E	e4	e5	e6	f1	f2	Pompa Pump Pumpe $f3$ 2)	h	h1	h2	h3	m1	m2	n1	n2	p1	p2	$\varnothing s$
42	569	151	31	270	200	215	325	28	22	-	107.5	170	-	180	505	300	32	160	36	222	24
52	644	241	31	315	230	252	390	38	28	155	127.5	210	190	240	580	360	32	175	36	272	24
62	724	241	31	350	230	252	430	38	28	155	127.5	210	190	240	660	360	32	220	36	272	24
72	789	241	37	385	280	292	430	42	30	150	150	210	165	250	715	430	37	215	36	332	28
82	894	241	37	430	280	302	490	42	32	150	150	210	165	250	820	430	37	275	36	332	28
92	929	331	47	450	320	342	565	42	32	140	185	280	205	330	845	490	42	260	41	372	36
102	1029	331	47	500	320	342	615	42	32	140	185	280	205	330	945	490	42	310	41	372	36
112	1109	331	56	545	380	402	600	48	35	150	215	280	240	340	1005	600	52	295	51	442	40
122	1264	331	56	615	380	410	685	48	35	150	215	280	240	340	1160	600	52	380	51	442	40

Ölçüler mm'dir.

1) Şaftlar:

$m6 \leq \varnothing 100$; $n6 > \varnothing 100$
Kama kanalı DIN 6885/1,
Kama kanalı genişliği ISO JS9 a göre
Kama DIN 6885/1 form B
Ayrıntılar için sayfa 127-136'ya bakılabilir.

2) Değişkenler: G,H ve I tasarımları ile flanşlı pompa mümkün değildir.

3) Soğutma serpantini:

A,C ve E dizaynları için Flanşlı pompa ile basınçlı yağlama mümkün değildir.

4) Pompa borusu ve koruyucusunun gerçek ölçülerinin boşluğu için lütfen PGR'ye danışınız.

5) Şaft montajlı redüktörler için A,D ve G montajı istendiğinde *) Yaklaşık değerlerdir. Kesin verilere siparişte gönderilen dokümanlardan ulaşılabilir.

**) Redüktörler yağsızdır.

Dimensions in mm

1) Shafts:

$m6 \leq \varnothing 100$; $n6 > \varnothing 100$
Keyway acc.to DIN 6885/1,
Hub keyway width acc.to ISO JS9
Parallel key acc.to DIN 6885/1 form B
For details, see pages 127-136

2) Variants:

Flanged - on pump not possible with G,H and I designs

3) Cooling coil:

For A,C and E designs, forced lubrication by flanged-on pump not possible.

4) Space for pump pipes and cover; for exact dimensions, please refer to us.

5) For shaft-mounted gear units, designs A,D and G on request.

*) Approximate values; exact data acc. to order related documentation.

**) Without oil filling

Abmessungen in mm

1) Wellen:

$m6 \leq \varnothing 100$; $n6 > \varnothing 100$
Passfedermut nach DIN 6885/1
Nabennutbreite nach ISO JS9
Passfeder nach DIN 6885/1 Form B
Einzelheiten siehe Seiten 127-136

2) Varianten:

Flanschpumpe nicht in Verbindung mit Ausführung G, H und I

3) Kühlschlange:

Ausführungen A,C und E mit Druckschmierung durch Flanschpumpe nicht möglich.

4) Freiraum für Pumpe, Rohre und Deckel genaue Maße ggf. anfragen.

5) Ausführungen A,D und G bei Aufsteckausführungen auf anfrage.

*) Richtwerte; genaue Angaben nach auftragsbezogener Dokumentation.

**) ohne Ölfüllung

TR İKİ KADEMELİ - DİKEY

EN TWO STAGE - VERTICAL

DE ZWEISTUFIG - VERTIKAL

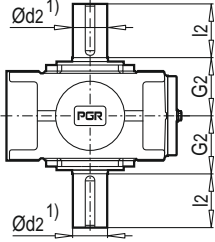
	<p>PH42-SV ... PH122-SV Mil Çıkışlı Solid shaft Vollwelle</p>		Ød2	l2	G2
		42	80	170	140
		52	100	210	165
		62	110	210	165
		72	120	210	195
		82	130	250	195
		92	140	250	235
		102	160	300	235
112	170	300	270		
122	180	300	270		

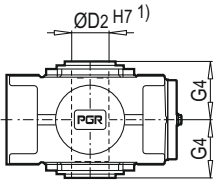
	<p>PH42-HV ... PH122-HV Delik milli Hollow shaft Hohlwelle</p>		ØD2	G4
		42	80	140
		52	95	165
		62	105	165
		72	115	195
		82	125	195
		92	135	235
		102	150	235
112	165	270		
122	180	270		

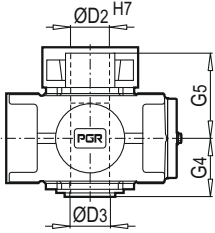
	<p>5) PH42-DV ... PH122-DV Konik Sıktırmalı Hollow shaft for shrink disk Hohlwelle für schrumpfscheibe</p>		ØD2	ØD3	G4	G5
		42	85	85	140	205
		52	100	100	165	240
		62	110	110	165	240
		72	120	120	195	280
		82	130	130	195	285
		92	140	145	235	330
		102	150	155	235	350
112	165	170	270	400		
122	180	185	270	405		

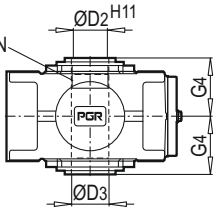
	<p>PH42-KV ... PH122-KV Spline DIN 5480 Hollow shaft with involute splines acc. to DIN 5480 Hohlwelle mit Zahnradprofil nach DIN 5480</p>		N / DIN 5480	ØD2	ØD3	G4
		42	-	-	-	-
		52	N 95x3x30x30x9H	89	100	165
		62	N 95x3x30x30x9H	89	110	165
		72	N 120x3x30x38x9H	114	120	195
		82	N 120x3x30x38x9H	114	130	195
		92	N 140x3x30x45x9H	134	145	235
		102	N 140x3x30x45x9H	134	155	235
112	N 170x5x30x32x9H	160	170	270		
122	N 170x5x30x32x9H	160	185	270		

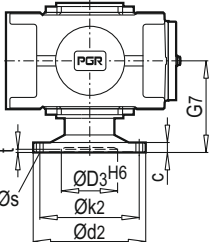
	<p>PH42-FV ... PH122-FV Flanşlı shaft Flanged shaft Flanschswelle</p>		c	Ød2	ØD3	Øk2	nxØs	t	G7
		42	-	-	-	-	-	-	-
		52	25	300	150	260	16 x 22	10	255
		62	25	320	160	280	18 x 22	10	255
		72	30	370	180	320	16 x 26	10	300
		82	30	390	190	340	18 x 26	10	300
		92	38	430	220	380	20 x 26	12	350
		102	38	470	240	420	22 x 26	12	350
112	42	510	260	450	18 x 33	12	400		
122	42	540	280	480	22 x 33	12	400		

Gövde Size Größe	Yağ miktarı / Oil quantity Ölmenge / (l)*)		Ağırlık / Weight / Gewicht (kg)*)**)	
	Daldırmalı yağlama Dip lubrication Tauch- schmierung	Basınçlı yağlama Forced lubrication Druck- schmierung	SV HV DV KV	FV
42	23	11.5	195	-
52	35	17.5	305	340
62	40	20	360	400
72	62	31	515	565
82	70	35	600	655
92	100	50	840	925
102	106	53	975	1065
112	166	83	1350	1480
122	180	90	1630	1770

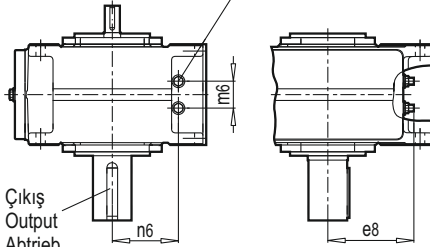
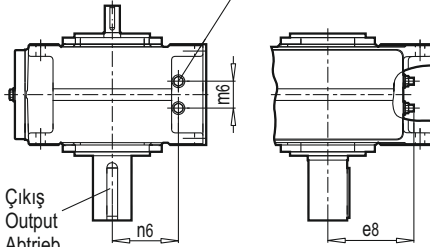
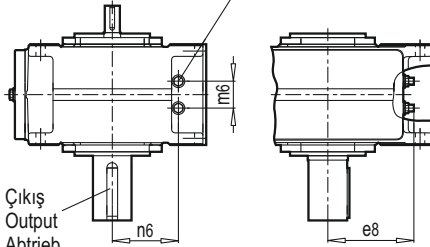
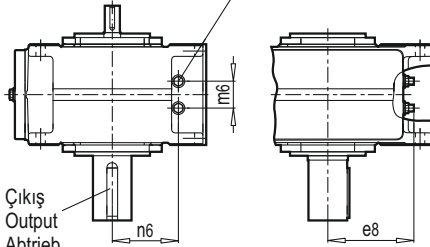
Soğutma serpantini / Cooling coil / Kühlschlange 3)					Gövde Size Größe	m6	n6	e8	l/min x)
Soğutma serpantini su bağlantısı G1/2" Water connection for cooling coil G1/2" Wasseranschluß für Kühlschlange G1/2"					42	90	144	157	4
					52	100	165	169	4
					62	100	165	214	4
					72	100	203	208	4
					82	100	203	266	4
					92	130	245	246	8
					102	130	245	294	8
					112	140	290	275	8
					122	140	290	360	8

Çıkış
Output
Abtrieb

x) Gerekli soğutma suyu miktarı;
basıncı 8 bar
Cooling water quantity required;
max. cooling water pressure: 8 bar
Erforderliche Kühlwassermenge,
max. Kühlwasserdruck: 8 bar

Soğutma sistemi deniz suyu ve acı su için uygundur
Cooling coil suitable for fresh, sea and brackish water
Kühlschlange geeignet für Süß-, See- und Brackwasser

SV
HV
DV
KV
FV

Flanşlı pompa ile basınçlı yağlama
Forced lubrication by flanged-on pump
Druckschmierung durch Flanshpumpe

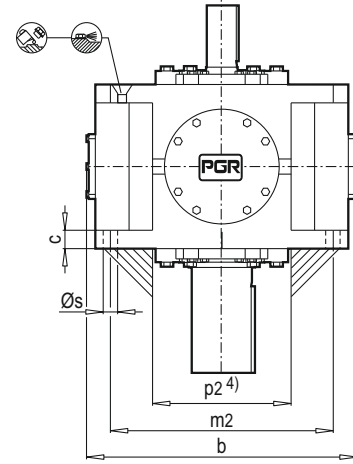
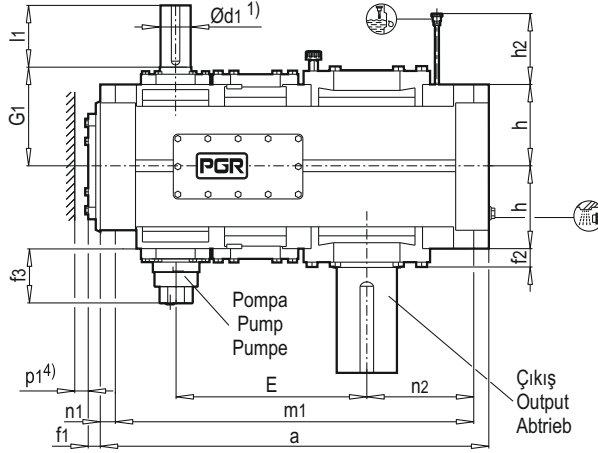

Gövde Size Größe	Giriş / Input / Antrieb												G1	2) Sadece G,H,I dizaynı için; IN Design G,H,I only for; IN Ausführung G,H,I nur für IN
	İN = 6.3 - 11.2		İN = 12.5 - 20		İN = 7.1 - 12.5		İN = 14 - 22.4		İN = 8 - 14		İN = 16 - 25			
	Ød1	l1	Ød1	l1	Ød1	l1	Ød1	l1	Ød1	l1	Ød1	l1		
132	100	205	85	170	-	-	-	-	-	-	-	-	330	6.3 - 16
142	-	-	-	-	-	-	-	-	100	205	85	170	330	8 - 20
152	120	210	100	210	-	-	-	-	-	-	-	-	365	6.3 - 16
162	-	-	-	-	120	210	100	210	-	-	-	-	365	7.1 - 18
172	125	245	110	210	-	-	-	-	-	-	-	-	420	6.3 - 16
182	-	-	-	-	125	245	110	210	-	-	-	-	420	7.1 - 18
192...222	Talep edildiğinde / On request / Auf Anfrage													

Gövde Size Größe	Redüktörler / Gear Units / Zahnradgetriebe															
	a	b	c	E	f1	f2	Pompa Pump Pumpe f3 2)	h	h2	m1	m2	n1	n2	p1	p2	Øs
132	1294	901	63	635	53	35	135	272.5	300	1195	680	52	360	51	502	48
142	1434	901	63	705	53	35	135	272.5	300	1335	680	52	430	51	502	48
152	1554	981	74	762	63	42	135	310	340	1435	750	62	430	51	572	55
162	1644	981	74	808	63	42	135	310	340	1525	750	62	475	51	572	55
172	1744	1111	83	860	60	42	175	340	374	1610	850	72	465	71	632	55
182	1864	1111	83	920	60	42	175	340	374	1730	850	72	525	71	632	55
192...222	Talep edildiğinde / On request / Auf Anfrage															

Ölçüler mm'dir.

1) Şaftlar:

m6<=Ø100; n6>Ø100
Kama kanalı DIN 6885/1,
Kama kanalı genişliği ISO JS9 a göre
Kama DIN 6885/1 form B
Ayrıntılar için sayfa 127-136'ya bakılabilir.

2) Değişkenler:

G,H ve I dizaynları ile flanşlı pompa mümkün değildir.

3) Soğutma serpantini:

A,C ve E dizaynları için Flanşlı pompa ile basınçlı yağlama mümkün değildir.

4) Pompa borusu ve koruyucusunun gerçek ölçülerinin boşluğu için lütfen PGR'ye danışınız

5) Şaft montajlı redüktörler için A,D ve G montajı istendiğinde.

6) 132 ve 152 gövdelerin sadece İN= 6.3 -18

172 ve 192 gövdelerin sadece İN= 6.3 -16

*) Yaklaşık değerlerdir. Kesin verilere siparişte gönderilen dokümanlardan ulaşılabilir.

**) Redüktörler yağsızdır.

Dimensions in mm

1) Shafts:

m6<=Ø100; n6>Ø100
Keyway acc.to DIN 6885/1,
Hub keyway width acc.to ISO JS9
Parallel key acc.to DIN6885/1 form B
For details, see pages 127-136

2) Variants:

Flanged-on pump not possible with G,H and I design

3) Cooling coil:

For A,C and E designs, forced lubrication by flanged-on pump not possible

4) Space for pump pipes and cover; for exact dimensions, please refer to us.

5) For shaft-mounted gear units, designs A,D and G on request.

6) Sizes 132 and 152 : only İN= 6.3 - 18

Sizes 172 and 192 : only İN= 6.3 - 16

*) Approximate values; exact data acc. to order related documentation.

**) Without oil filling

Abmessungen in mm

1) Wellen:

m6<=Ø100; n6>Ø100
Passfedernut nach DIN 6885/1
Nabennutbreite nach ISO JS9
Passfeder nach DIN 6885/1 Form B
Einzelheiten siehe Seiten 127-136

2) Varianten:

Flanshpumpe nicht in Verbindung mit Ausführung G,H und I

3) Kühlschlange:

Ausführungen A,C und E mit Druckschmierung durch Flanshpumpe nicht möglich.

4) Freiraum für Pumpe, Rohre und Deckel genaue Maße ggf. anfragen.

5) Ausführungen A,D und G bei Aufsteckausführungen auf Anfrage.

6) Größen 132 und 152: nur İN= 6.3 - 18

Größen 172 und 192: nur İN= 6.3 - 16

*) Richtwerte; genaue Angaben nach auftragsbezogener Dokumentation.

**) ohne Ölfüllung

TR İKİ KADEMELİ - DİKEY

EN TWO STAGE - VERTICAL

DE ZWEISTUFIG - VERTIKAL

	<p>PH132-SV ... PH222-SV Mil Çıkışı Solid shaft Vollwelle</p>		Ød2	l2	G2
		132	200	350	335
		142	210	350	335
		152	230	410	380
		162	240	410	380
		172	250	410	415
		182	270	470	415
		192	Talep edildiğinde		
202	On request				
212	Auf Anfrage				
222					

	<p>PH132-HV ... PH222-HV Delik millî Hollow shaft Hohlwelle</p>	6)		ØD2	G4
		132	190	335	
		142	210	335	
		152	230	380	
		162	240	380	
		172	250	415	
		182	275	415	
		192	Talep edildiğinde		
202	On request				
212	Auf Anfrage				
222					

	<p>PH132-DV ... PH222-DV Konik Sıktırmalı Hollow shaft for shrink disk Hohlwelle für schrumpfscheibe</p>	5) 6)		ØD2	ØD3	G4	G5
		132	190	195	335	480	
		142	210	215	335	480	
		152	230	235	380	550	
		162	240	245	380	550	
		172	250	260	415	600	
		182	280	285	415	600	
		192	Talep edildiğinde				
202	On request						
212	Auf Anfrage						
222							

	<p>PH132-KV ... PH222-KV Spline DIN 5480 Hollow shaft with involute splines acc. to DIN 5480 Hohlwelle mit Zahnablenprofil nach DIN 5480</p>	6)		N / DIN 5480	ØD2	ØD3	G4
		132	N 190x5x30x36x9H	180	195	335	
		142	N 190x5x30x36x9H	180	215	335	
		152	N 220x5x30x42x9H	210	235	380	
		162	N 220x5x30x42x9H	210	245	380	
		172	N 250x5x30x48x9H	240	260	415	
		182	N 250x5x30x48x9H	240	285	415	
		192	Talep edildiğinde				
202	On request						
212	Auf Anfrage						
222							

	<p>PH134-FV ... PH224-FV Flanşlı shaft Flanged shaft Flanschswelle</p>		c	Ød2	ØD3	Øk2	nxØs	t	G7
		132	48	580	310	500	20 x 33	14	480
		142	48	620	310	540	24 x 33	14	480
		152	55	710	360	630	28 x 33	17	550
		162	55	740	360	660	30 x 33	17	550
		172	60	750	410	660	24 x 39	18	600
		182	60	800	410	710	26 x 39	18	600
		192	Talep edildiğinde						
202	On request								
212	Auf Anfrage								
222									

Gövde Size GröÙe	Yağ miktarı Oil quantity Ölmenge (l *)	Ağırlık / Weight / Gewicht (kg)***)		Soğutma serpantini / Cooling coil / Kùhlschlange	3)	Gövde Size GröÙe	m6	n6	e8	l/min x)
		SV HV DV KV	FV							
132	120	1890	2050	<p>Soğutma serpantini su bağlantısı G1/2" Water connection for cooling coil G1/2" WasseranschlulÙ für Kùhlschlange G1/2"</p>	<p>Soğutma sistemi deniz suyu ve acı su için uygundur Cooling coil suitable for fresh, sea and brackish water Kùhlschlange geeignet für SüÙ-, See- und Brackwasser</p>	132	252	300	335	8
142	135	2440	2610			142	252	300	405	8
152	185	3255	3495			152	290	335	395	8
162	200	3470	3735			162	290	335	440	8
172	265	4440	4740			172	340	380	425	8
182	285	4900	5250			182	340	380	485	8
192	Talep edildiğinde		<p>x) Gereki soğutma suyu miktarı; basıncı 8 bar Cooling water quantity required; max. cooling water pressure: 8 bar Erforderliche Kùhlwassermenge; max. Kùhlwasserdruck: 8 bar</p>			192	Talep edildiğinde			
202	On request					202	On request			
212	Auf Anfrage			212	Auf Anfrage					
222				222						

TR

ÜÇ KADEMELİ - DİKEY

EN

THREE STAGE - VERTICAL

DE

DREISTUFIG - VERTIKAL

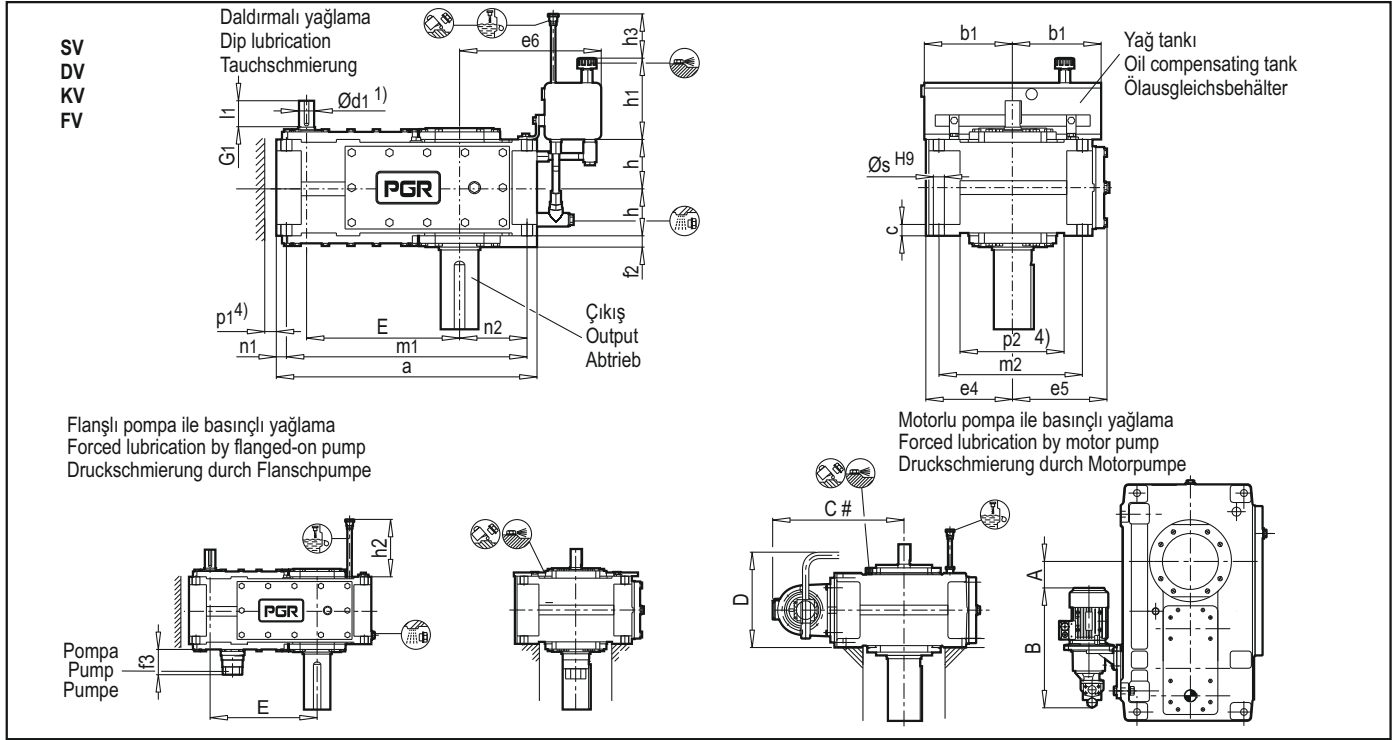

Gövde Size Größe	Giriş / Input / Antrieb												G1
	İN = 25 - 45		İN = 50 - 63		İN = 71 - 90		İN = 31.5 - 56		İN = 63 - 80		İN = 90 - 112		
	Ød1	l1	Ød1	l1	Ød1	l1	Ød1	l1	Ød1	l1	Ød1	l1	
53	40	70	30	50	24	40	-	-	-	-	-	-	160
63	-	-	-	-	-	-	40	70	30	50	24	40	160
73	45	80	35	60	28	50	-	-	-	-	-	-	185
83	-	-	-	-	-	-	45	80	35	60	28	50	185
93	60	125	45	100	32	80	-	-	-	-	-	-	230
103	-	-	-	-	-	-	60	125	45	100	32	80	230
113	70	120	50	80	42	70	-	-	-	-	-	-	255
123	-	-	-	-	-	-	70	120	50	80	42	70	255

Gövde Size Größe	Redüktörler / Gear Units / Zahnradgetriebe																		Motor Pompası Motor pump Motorpumpe					
	a	b1	c	E	e4	e5	e6	f2	Pompa Pump Pumpe f3 2)	h	h1	h2	h3	m1	m2	n1	n2	p1	p2	Øs	A #)	B #)	C #)	D #)
53	694	241	31	405	230	252	390	28	195	127.5	205	190	240	630	360	32	175	36	272	24	Talep edildiğinde On request Auf Anfrage			
63	774	241	31	440	230	252	430	28	195	127.5	205	190	240	710	360	32	220	36	272	24				
73	849	241	37	495	280	292	430	30	190	150	205	165	250	775	430	37	215	36	332	28				
83	954	241	37	540	280	302	490	32	190	150	205	165	250	880	430	37	275	36	332	28				
93	1004	331	47	580	320	342	565	32	175	185	275	205	330	920	490	42	260	41	372	36				
103	1104	331	47	630	320	342	615	32	175	185	275	205	330	1020	490	42	310	41	372	36				
113	1204	331	56	705	380	402	600	35	175	215	275	240	340	1100	600	52	295	51	442	40				
123	1359	331	56	775	380	410	685	35	175	215	275	240	340	1255	600	52	380	51	442	40				

Ölçüler mm'dir.

1) Şaftlar:

k6=Ø24; Ø28≤m6≤Ø100; n6>Ø100

Kama kanalı DIN 6885/1,

Kama kanalı genişliği ISO JS9 a göre

Kama DIN 6885/1 form B

Ayrıntılar için sayfa 127-136'ya bakılabilir.

2) Değişkenler:

G,H ve I dizaynları ile flanşlı pompa mümkün değildir.

3) Soğutma serpantini:

A,C ve E dizaynları için Flanşlı pompa ile basınçlı yağlama mümkün değildir.

Motorlu pompa ile basınçlı yağlama istek üzerine yapılmaktadır.

4) Pompa borusu ve koruyucusunun gerçek ölçülerinin boşluğu için Lütfen PGR'ye danışınız.

5) Şaft montajlı redüktörler için A, D ve G montajı istendiğinde

*) Yaklaşık değerlerdir. Kesin verilere siparişte gönderilen dokümanlardan ulaşılabilir.

**) Redüktörler yağsızdır.

Dimensions in mm

1) Shafts:

k6=Ø24; Ø28≤m6≤Ø100; n6>Ø100

Keyway acc.to DIN 6885/1,

Hub keyway width acc.to ISO JS9

Parallel key acc.to DIN 6885/1 form B

For details, see pages 127-136

2) Variants:

Flanged-on pump not possible with G,H and I design

3) Cooling coil:

For A,C and E designs, forced lubrication by flanged-on pump not possible

Combination with forced lubrication by motor pump on request

4) Space for pump pipes and cover; for exact dimensions, please refer to us.

5) For shaft-mounted gear units, designs A,D and G on request.

*) Approximate values; exact data acc. to order related documentation.

**) Without oil filling

Abmessungen in mm

1) Wellen:

k6=Ø24; Ø28≤m6≤Ø100; n6>Ø100

Passfedermut nach DIN 6885/1

Nabennutbreite nach ISO JS9

Passfeder nach DIN 6885/1 Form B

Einzelheiten siehe Seiten 127-136

2) Varianten:

Flanscpumpe nicht in Verbindung mit Ausführung G,H und I

3) Kühlschlange:

Ausführungen A, C und E mit Druckschmierung durch Flanscpumpe nicht möglich.

Kombination mit Druckschmierung durch Motorpumpe auf Anfrage.

4) Freiraum für Pumpe, Rohre und Deckel genaue Maße ggf. anfragen.

5) Ausführungen A, D und G bei Aufsteckausführungen auf Anfrage.

*) Richtwerte; genaue Angaben nach auftragsbezogener Dokumentation.

**) ohne Ölfüllung

TR ÜÇ KADEMELİ - DİKEY

EN THREE STAGE - VERTICAL

DE DREISTUFIG - VERTIKAL

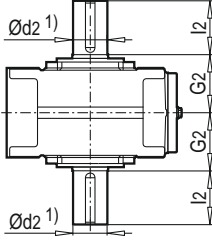
	<p>PH53-SV ... PH123-SV Mil Çıkışlı Solid shaft Vollwelle</p>		Ød2	l2	G2
		53	100	210	165
		63	110	210	165
		73	120	210	195
		83	130	250	195
		93	140	250	235
		103	160	300	235
		113	170	300	270
123	180	300	270		

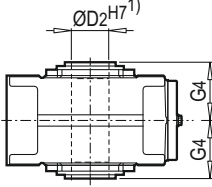
	<p>PH53-HV ... PH123-HV Delik millî Hollow shaft Hohlwelle</p>		ØD2	G4
		53	95	165
		63	105	165
		73	115	195
		83	125	195
		93	135	235
		103	150	235
		113	165	270
123	180	270		

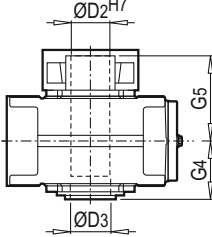
	<p>5) PH53-DV ... PH123-DV Konik Sıktırmalı Hollow shaft for shrink disk Hohlwelle für schrumpfscheibe</p>		ØD2	ØD3	G4	G5
		53	100	100	165	240
		63	110	110	165	240
		73	120	120	195	280
		83	130	130	195	285
		93	140	145	235	330
		103	150	155	235	350
		113	165	170	270	400
123	180	185	270	405		

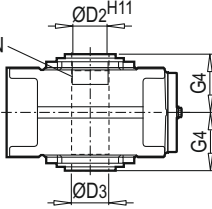
	<p>PH53-KV ... PH123-KV Spline DIN 5480 Hollow shaft with involute splines acc. to DIN 5480 Hohlwelle mit Zahnabprofil nach DIN 5480</p>		N / DIN 5480	ØD2	ØD2	G4
		53	N 95x3x30x30x9H	89	100	165
		63	N 95x3x30x30x9H	89	110	165
		73	N 120x3x30x38x9H	114	120	195
		83	N 120x3x30x38x9H	114	130	195
		93	N 140x3x30x45x9H	134	145	235
		103	N 140x3x30x45x9H	134	155	235
		113	N 170x5x30x32x9H	160	170	270
123	N 170x5x30x32x9H	160	185	270		

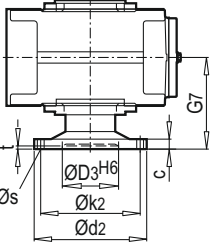
	<p>PH53-FV ... PH123-FV Flanşlı shaft Flanged shaft Flanschswelle</p>		c	Ød2	ØD3	Øk2	nxØs	t	G7
		53	25	300	150	260	16 x 22	10	255
		63	25	320	160	280	18 x 22	10	255
		73	30	370	180	320	16 x 26	10	300
		83	30	390	190	340	18 x 26	10	300
		93	38	430	220	380	20 x 26	12	350
		103	38	470	240	420	22 x 26	12	350
		113	42	510	260	450	18 x 33	12	400
123	42	540	280	480	22 x 33	12	400		

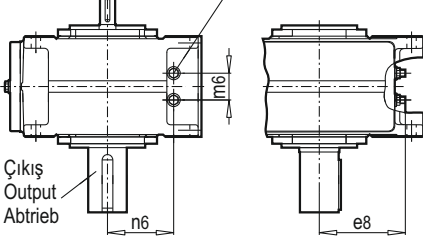
Gövde Size Größe	Yağ miktarı / Oil quantity Ölmenge (l) *)		Ağırlık / Weight Gewicht (kg) **)***)		Soğutma serpantini / Cooling coil / Kùhlschlange 3)	Gövde Size Größe	m6	n6	e8	l/min x)
	Daldırma yağlama Dip lubrication Tauchschmierung	Basıncılı yağlama Forced lubrication Druck- schmierung	SV HV DV KV	FV						
53	37	24.5	325	360	 <p>Soğutma sistemi deniz suyu ve acı su için uygundur Cooling coil suitable for fresh, sea and brackish water Kùhlschlange geeignet für Süß-, See- und Brackwasser</p>	53	100	165	169	4
63	40	27	370	410		63	100	165	214	4
73	64	42	550	600		73	100	203	208	4
83	76	50	635	690		83	100	203	266	4
93	106	71	885	970		93	130	245	246	4
103	116	77	1035	1125		103	130	245	294	4
113	185	109	1415	1545		113	140	290	275	8
123	200	118	1690	1830		123	140	290	360	8

x) Gereklî soğutma suyu miktarı;
basıncı 8 bar
Cooling water quantity required;
max. cooling water pressure: 8 bar
Erforderliche Kùhlwassermenge,
max. Kùhlwasserdruck: 8 bar

TR

ÜÇ KADEMELİ - DİKEY

EN

THREE STAGE - VERTICAL

DE

DREISTUFIG - VERTIKAL

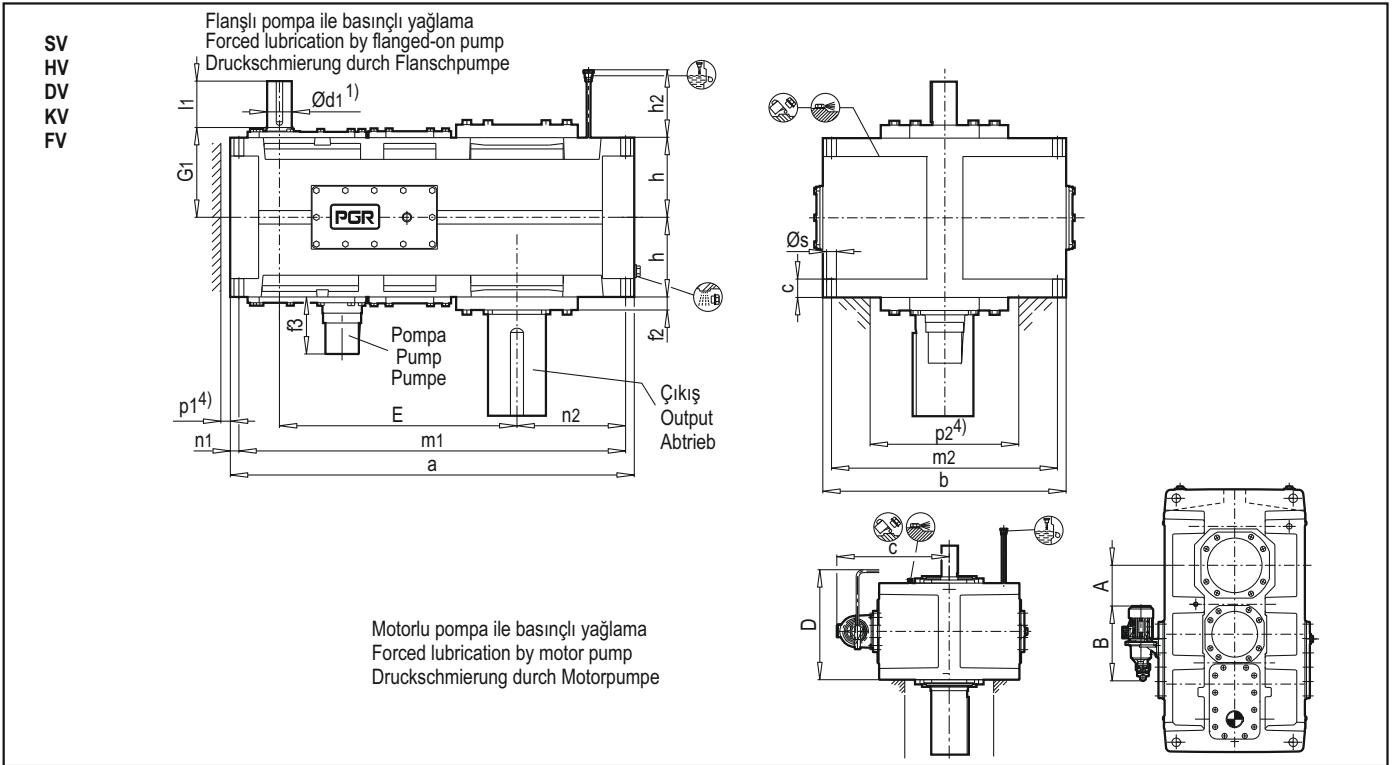

Gövde Size Größe	Giriş / Input / Antrieb																		G1
	İN = 22.4 - 45		İN = 50 - 63		İN = 71 - 90		İN = 25 - 50		İN = 56 - 71		İN = 80 - 100		İN = 28 - 56		İN = 63 - 80		İN = 90 - 112		
	Ød1	l1	Ød1	l1	Ød1	l1	Ød1	l1	Ød1	l1	Ød1	l1	Ød1	l1	Ød1	l1	Ød1	l1	
133	85	160	60	135	50	110	-	-	-	-	-	-	-	-	-	-	-	-	310
143	-	-	-	-	-	-	-	-	-	-	-	-	85	160	60	135	50	110	310
153	100	200	75	140	60	140	-	-	-	-	-	-	-	-	-	-	-	-	350
163	-	-	-	-	-	-	100	200	75	140	60	140	-	-	-	-	-	-	350
173	100	200	75	140	60	140	-	-	-	-	-	-	-	-	-	-	-	-	380
183	-	-	-	-	-	-	100	200	75	140	60	140	-	-	-	-	-	-	380
193...223	Talep edildiğinde / On request / Auf Anfrage																		

Gövde Size Größe	Redüktörler / Gear Units / Zahnradgetriebe															Motor Pompası Motor pump / Motorpumpe			
	a	b	c	E	f2	Pompa Pump Pumpe f3 2)	h	h2	m1	m2	n1	n2	p1	p2	Øs	A #)	B #)	C #)	D #)
133	1399	901	63	820	35	175	272.5	300	1300	680	52	360	51	502	48	Talep edildiğinde On request Auf Anfrage			
143	1539	901	63	890	35	175	272.5	300	1440	680	52	430	51	502	48				
153	1684	981	74	987	42	175	310	340	1565	750	62	430	51	572	55				
163	1774	981	74	1033	42	175	310	340	1655	750	62	475	51	572	55				
173	1774	1111	83	1035	42	215	340	374	1640	850	72	465	71	632	55				
183	1894	1111	83	1095	42	215	340	374	1760	850	72	525	71	632	55				
193...223	Talep edildiğinde / On request / Auf Anfrage																		

#) Max ölçülerdir. Ayrıntılara siparişte gönderilen dökümanlardan ulaşılabilir. Ölçüler mm'dir.

1) **Şaftlar:**
m6<=Ø100; n6>Ø100
Kama kanalı DIN 6885/1,
Kama kanalı genişliği ISO JS9 a göre
Kama DIN 6885/1 form B
Ayrıntılar için sayfa 127-136'ya bakılabilir.

2) **Değişkenler:**
G,H ve I dizaynları ile flanşlı pompa mümkün değildir.

3) **Soğutma serpantini:**
A,C ve E dizaynları için Flanşlı pompa ile basınçlı yağlama mümkün değildir.
Motorlu pompa ile basınçlı yağlama istek üzerine yapılmaktadır.

4) Pompa borusu ve koruyucusunun gerçek ölçülerinin boşluğu için Lütfen PGR'ye danışınız.

5) Şaft montajlı redüktörler için A,D ve G montajı istendiğinde
*) Yaklaşık değerlerdir. Kesin verilere siparişte gönderilen dökümanlardan ulaşılabilir.

**) Redüktörler yağsızdır.

#) Max dimensions; details acc. to order-related documentation. Dimensions in mm

1) **Shafts:**
m6<=Ø100; n6>Ø100
Keyway acc.to DIN 6885/1,
Hub keyway width acc.to ISO JS9
Parallel key acc.to DIN 6885/1 form B
For details, see pages 127-136

2) **Variants:**
Flanged-on pump not possible with G,H and I designs

3) **Cooling coil:**
For A,C and E designs, forced lubrication by flanged-on pump not possible
Combination with forced lubrication by motor pump on request

4) Space for pump pipes and cover; for exact dimensions, please refer to us.

5) For shaft-mounted gear units, designs A,D and G on request.

*) Approximate values; exact data acc. to order related documentation.

**) Without oil filling

#) Max. Abmessungen; Einzelheiten nach auftragsbezogener Dokumentation. Abmessungen in mm

1) **Wellen:**
m6<=Ø100; n6>Ø100
Passfedernut nach DIN 6885/1
Nabennutbreite nach ISO JS9
Passfeder nach DIN 6885/1 Form B
Einzelheiten siehe Seiten 127-136

2) **Varianten:**
Flanschpumpe nicht in Verbindung mit Ausführung G,H and I

3) **Kühlschlange:**
Ausführungen A, C und E mit Druckschmierung durch Flanschpumpe nicht möglich.
Kombination mit Druckschmierung durch Motorpumpe Auf Anfrage.

4) Freiraum für Pumpe, Rohre und Deckel genaue Maße ggf. anfragen.

5) Ausführungen A,D und G bei Aufsteckausführungen auf Anfrage.

*) Richtwerte; genaue Angaben nach auftragsbezogener Dokumentation.

**) ohne Ölfüllung

TR ÜÇ KADEMELİ - DİKEY

EN THREE STAGE - VERTICAL

DE DREISTUFIG - VERTIKAL

	<p>PH133-SV ... PH223-SV Mil Çıkışlı Solid shaft Vollwelle</p>		Ød2	l2	G2
		133	200	350	335
		143	210	350	335
		153	230	410	380
		163	240	410	380
		173	250	410	415
		183	270	470	415
		193	Talep edildiğinde		
		203	On request		
		213	Auf Anfrage		
223	Auf Anfrage				

	<p>PH133-HV ... PH223-HV Delik millî Hollow shaft Hohlwelle</p>		ØD2	G4
		133	190	335
		143	210	335
		153	230	380
		163	240	380
		173	250	415
		183	275	415
		193	Talep edildiğinde	
		203	On request	
		213	Auf Anfrage	
223	Auf Anfrage			

	<p>5) PH133-DV ... PH223-DV Konik Sıktırmalı Hollow shaft for shrink disk Hohlwelle für schrumpfscheibe</p>		ØD2	ØD3	G4	G5
		133	190	195	335	480
		143	210	215	335	480
		153	230	235	380	550
		163	240	245	380	550
		173	250	260	415	600
		183	280	285	415	600
		193	Talep edildiğinde			
		203	On request			
		213	Auf Anfrage			
223	Auf Anfrage					

	<p>PH133-KV ... PH223-KV Spline DIN 5480 Hollow shaft with involute splines acc. to DIN 5480 Hohlwelle mit Zahnradprofil nach DIN 5480</p>		N / DIN 5480		ØD2	ØD3	G4
		133	N 190x5x30x36x9H		180	195	335
		143	N 190x5x30x36x9H		180	215	335
		153	N 220x5x30x42x9H		210	235	380
		163	N 220x5x30x42x9H		210	245	380
		173	N 250x5x30x48x9H		240	260	415
		183	N 250x5x30x48x9H		240	285	415
		193	Talep edildiğinde				
		203	On request				
		213	Auf Anfrage				
223	Auf Anfrage						

	<p>PH133-FV ... PH223-FV Flanşlı shaft Flanged shaft Flanschswelle</p>		c	Ød2	ØD3	Øk2	nxØs	t	G7
		133	48	580	310	500	20 x 33	14	480
		143	48	620	310	540	24 x 33	14	480
		153	55	710	360	630	28 x 33	17	550
		163	55	740	360	660	30 x 33	17	550
		173	60	750	410	660	24 x 39	18	600
		183	60	800	410	710	26 x 39	18	600
		193	Talep edildiğinde						
		203	On request						
		213	Auf Anfrage						
223	Auf Anfrage								

Gövde Size Größe	Yağ miktarı Oil quantity Ölmenge (l *)	Ağırlık / Weight Gewicht (kg) (**)	
		SV HV DV KV	FV
133	160	2175	2335
143	180	2510	2680
153	255	3280	3520
163	260	3650	3905
173	325	4280	4580
183	335	4775	5125
193	Talep edildiğinde		
203	On request		
213	Auf Anfrage		
223	Auf Anfrage		

Soğutma serpantini / Cooling coil / Kühlschlange 3)

Soğutma serpantini su bağlantısı G1/2"
Water connection for cooling coil G1/2"
Wasseranschluß für Kühlschlange G1/2"

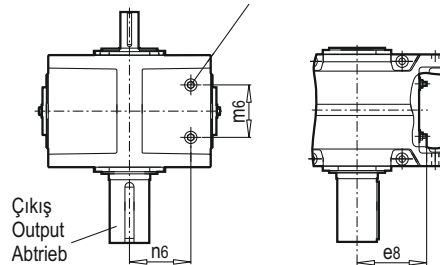

Soğutma sistemi deniz suyu ve acı su için uygundur
Cooling coil suitable for fresh, sea and brackish water
Kühlschlange geeignet für Süß-, See- und Brackwasser

Gövde Size Größe	m6	n6	e8	l/min x)
133	252	300	335	8
143	252	300	405	8
153	290	340	395	8
163	290	340	440	8
173	300	380	425	8
183	300	380	485	8
193...223	Talep edildiğinde			
				On request
				Auf Anfrage

x) Gereki soğutma suyu miktarı;
basıncı 8 bar
Cooling water quantity required;
max. cooling water pressure: 8 bar
Erforderliche Kühlwassermenge,
max. Kühlwasserdruck: 8 bar

TR

DÖRT KADEMELİ - DİKEY

EN

FOUR STAGE - VERTICAL

DE

VIERSTUFIG - VERTIKAL

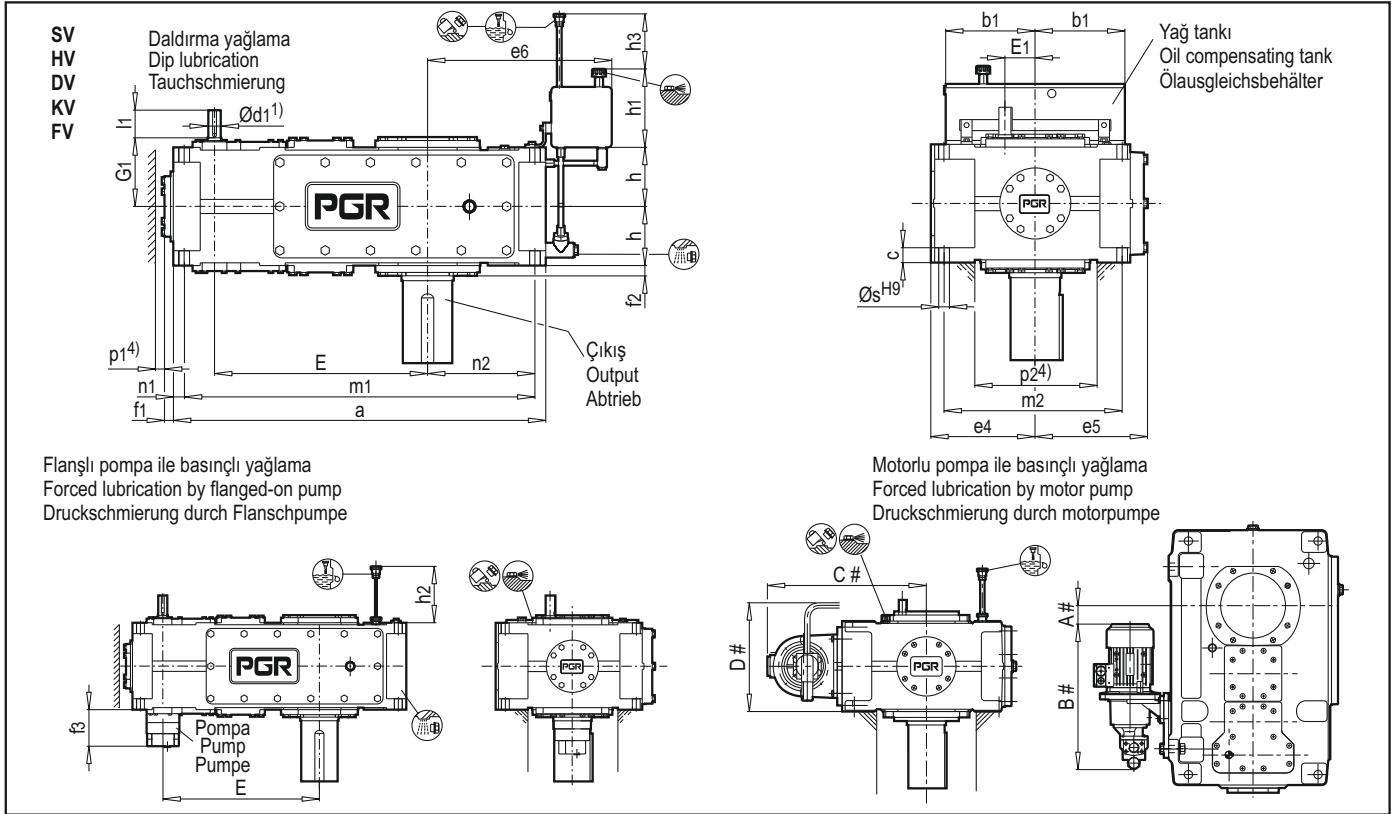

Gövde Size Größe	Giriş / Input / Antrieb								G1	2) Sadece G,H,I dizaynı için; IN Design G,H,I only for; IN Ausführung G,H,I nur für IN
	İN = 100 - 180		İN = 200 - 355		İN = 125 - 224		İN = 250 - 450			
	Ød1	l1	Ød1	l1	Ød1	l1	Ød1	l1		
74	30	50	24	40	-	-	-	-	180	100 - 224
84	-	-	-	-	30	50	24	40	180	125 - 280
94	35	60	28	50	-	-	-	-	215	100 - 250
104	-	-	-	-	35	60	28	50	215	125 - 315
114	45	100	32	80	-	-	-	-	250	100 - 250
124	-	-	-	-	45	100	32	80	250	125 - 315

Gövde Size Größe	Redüktörler / Gear Units / Zahnradgetriebe																			Motor Pompası Motor pump Motorpumpe						
	a	b1	c	E	E1	e4	e5	e6	f1	f2	Pompa Pump Pumpe f3 2)	h	h1	h2	h3	m1	m2	n1	n2	p1	p2	Øs	A #)	B #)	C #)	D #)
74	849	241	37	495	80	280	292	430	37	30	165	150	205	165	250	775	430	37	215	36	332	28	Talep edildiğinde On request Auf Anfrage			
84	954	241	37	540	80	280	302	490	37	32	165	150	205	165	250	880	430	37	275	36	332	28				
94	1004	331	47	580	90	320	342	565	43	32	175	185	275	205	330	920	490	42	260	41	372	36				
104	1104	331	47	630	90	320	342	615	43	32	175	185	275	205	330	1020	490	42	310	41	372	36				
114	1204	331	56	705	110	380	402	600	47	35	175	215	275	240	340	1100	600	52	295	51	442	40				
124	1359	331	56	775	110	380	410	685	47	35	175	215	275	240	340	1255	600	52	380	51	442	40				

#) Max ölçülerdir. Ayrıntılara siparişte gönderilen dökümanlardan ulaşılabilir.
Ölçüler mm'dir.

- 1) **Şaftlar:**
k6=Ø24; Ø28≤m6≤Ø100; n6>Ø100
Kama kanalı DIN 6885/1,
Kama kanalı genişliği ISO JS9 a göre
Kama DIN 6885/1 form B
Ayrıntılar için sayfa 127-136'ya bakılabilir.

2) **Değişkenler:**

- G,H ve I dizaynları ile flanşlı pompa mümkün değildir.
4) Pompa borusu ve koruyucusunun gerçek ölçülerinin boşluğu için Lütfen PGR'ye danışınız
5) Şaft montajlı redüktörler için A, D ve G montajı istendiğinde
*) Yaklaşık değerlerdir. Kesin verilere siparişte gönderilen dökümanlardan ulaşılabilir.
**) Redüktörler yağsızdır.

#) Max.dimensions; details acc. to order-related documentation.

Dimensions in mm

- 1) **Shafts:**
k6=Ø24; Ø28≤m6≤Ø100; n6>Ø100
Keyway acc.to DIN 6885/1,
Hub keyway width acc.to ISO JS9
Parallel key acc.to DIN 6885/1 form B
For details, see pages 127-136

2) **Variants:**

- Flanged-on pump not possible with G,H and I designs
4) Space for pump pipes and cover; for exact dimensions, please refer to us.
5) For shaft-mounted gear units, designs A,D and G on request.
*) Approximate values; exact data acc. to order related documentation.
**) Without oil filling

#) Max. Abmessungen; Einzelheiten nach auftragsbezogener Dokumentation.
Abmessungen in mm

- 1) **Wellen:**
k6=Ø24; Ø28≤m6≤Ø100; n6>Ø100
Passfedernut nach DIN 6885/1
Nabennutbreite nach ISO JS9
Passfeder nach DIN 6885/1 Form B
Einzelheiten siehe Seiten 127-136

2) **Varianten:**

- Flanschpumpe nicht in Verbindung mit Ausführung G,H and I
4) Freiraum für Pumpe, Rohre und Deckel genaue Maße ggf. anfragen.
5) Ausführungen A, D und G bei Aufsteckausführungen auf Anfrage.
*) Richtwerte; genaue Angaben nach auftragsbezogener Dokumentation.
**) ohne Ölfüllung

TR DÖRT KADEMELİ - DİKEY

EN FOUR STAGE - VERTICAL

DE VIERSTUFIG - VERTIKAL

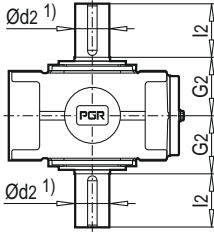
	<p>PH74-SV ... PH124-SV Mil Çıkışlı Solid shaft Vollwelle</p>		Ød2	l2	G2
		74	120	210	195
		84	130	250	195
		94	140	250	235
		104	160	300	235
		114	170	300	270
		124	180	300	270

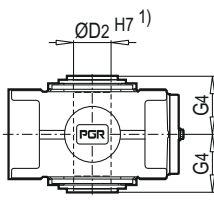
	<p>PH74-HV ... PH124-HV Delik milli Hollow shaft Hohlwelle</p>		ØD2	G4
		74	115	195
		84	125	195
		94	135	235
		104	150	235
		114	165	270
		124	180	270

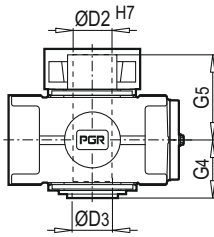
	<p>5) PH74-DV ... PH124-DV Konik Sıktırmalı Hollow shaft for shrink disk Hohlwelle für schrumpfscheibe</p>		ØD2	ØD3	G4	G5
		74	120	120	195	280
		84	130	130	195	285
		94	140	145	235	330
		104	150	155	235	350
		114	165	170	270	400
		124	180	185	270	405

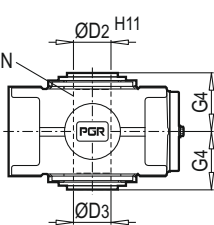
	<p>PH74-KV ... PH124-KV Spline DIN 5480 Hollow shaft with involute splines acc. to DIN 5480 Hohlwelle mit Zahnradprofil nach DIN 5480</p>		N / DIN 5480		ØD2	ØD3	G4
		74	N 120x3x30x38x9H		114	120	195
		84	N 120x3x30x38x9H		114	130	195
		94	N 140x3x30x45x9H		134	145	235
		104	N 140x3x30x45x9H		134	155	235
		114	N 170x5x30x32x9H		160	170	270
		124	N 170x5x30x32x9H		160	185	270

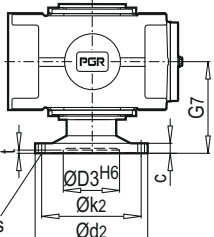
	<p>PH74-FV ... PH124-FV Flanşlı şaft Flanged shaft Flanschswelle</p>		c	Ød2	ØD3	Øk2	nxØs	t	G7
		74	30	370	180	320	16 x 26	10	300
		84	30	390	190	340	18 x 26	10	300
		94	38	430	220	380	20 x 26	12	350
		104	38	470	240	420	22 x 26	12	350
		114	42	510	260	450	18 x 33	12	400
		124	42	540	280	480	22 x 33	12	400

Gövde Size Größe	Yağ miktarı / Oil quantity Ölmenge (l) *)		Ağırlık / Weight Gewicht (kg) **)	
	Daldırmalı yağlama Dip lubrication Tauch- schmierung	Basınçlı yağlama Forced lubrication Druck- schmierung	SV HV DV KV	FV
74	62	46	555	605
84	70	52	650	705
94	108	80	885	970
104	110	81	1020	1110
114	180	120	1475	1605
124	210	135	1740	1880

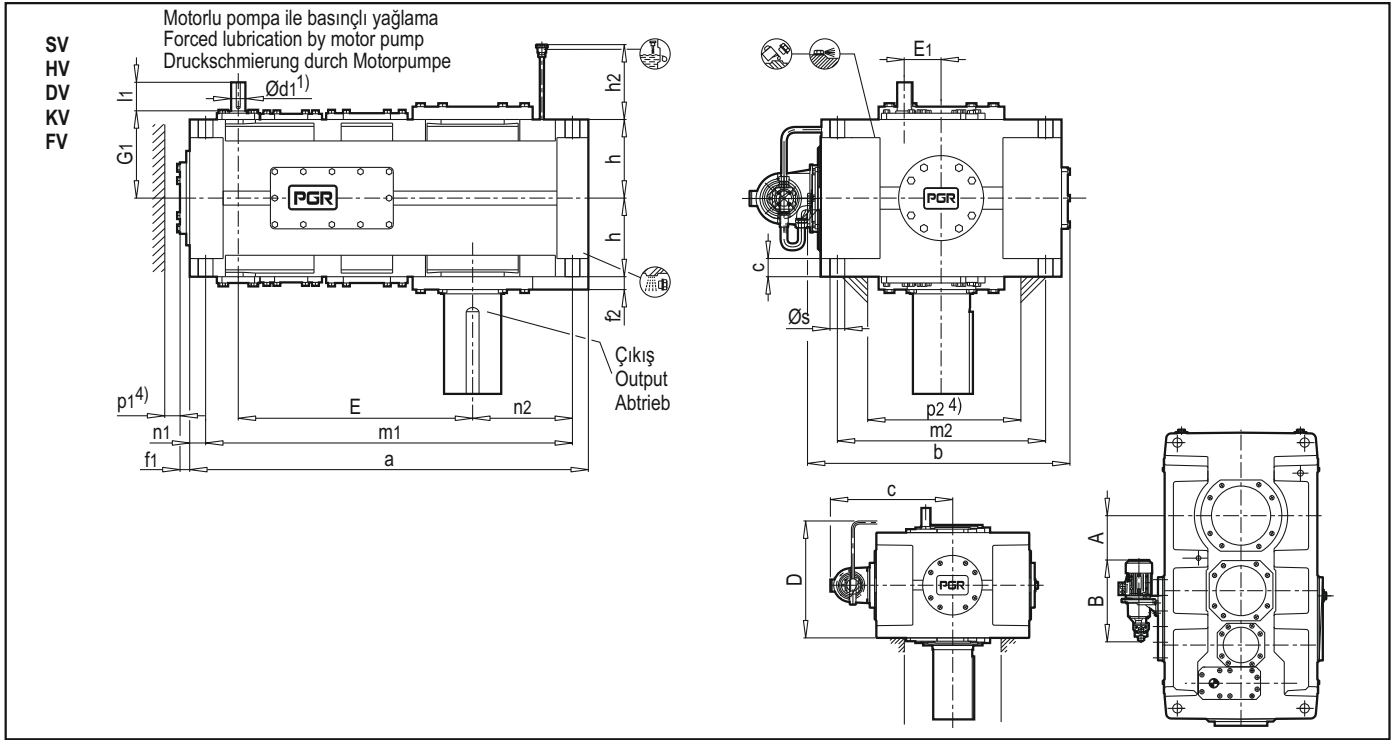

Gövde Size Größe	Giriş / Input / Antrieb												G1	2) Sadece G,H,I dizaynı için; İN Design G,H,I only for; İN Ausführung G,H,I nur für İN
	İN = 100 - 180		İN = 200 - 355		İN = 112 - 200		İN = 224 - 400		İN = 125 - 224		İN = 250 - 450			
	Ød1	l1	Ød1	l1	Ød1	l1	Ød1	l1	Ød1	l1	Ød1	l1		
134	50	100	38	80	-	-	-	-	-	-	-	-	305	100 - 250
144	-	-	-	-	-	-	-	-	50	100	38	80	305	125 - 315
154	60	135	50	110	-	-	-	-	-	-	-	-	345	100 - 250
164	-	-	-	-	60	135	50	110	-	-	-	-	345	112 - 280
174	60	105	50	80	-	-	-	-	-	-	-	-	380	-
184	-	-	-	-	60	105	50	80	-	-	-	-	380	-
194...224	Talep edildiğinde / On request / Auf Anfrage													

Gövde Size Größe	Redüktörler / Gear Units / Zahnradgetriebe																Motor Pompası Motor pump / Motorpumpe			
	a	b	c	E	E1	f1	f2	h	h2	m1	m2	n1	n2	p1	p2	Øs	A#)	B#)	C#)	D#)
134	1400	901	63	820	130	47	35	272.5	300	1300	680	52	360	51	502	48	Talep edildiğinde On request Auf Anfrage			
144	1540	901	63	890	130	47	35	272.5	300	1440	680	52	430	51	502	48				
154	1685	981	74	987	160	56	42	310	340	1565	750	62	430	61	572	55				
164	1775	981	74	1033	160	56	42	310	340	1655	750	62	475	61	572	55				
174	1775	1111	83	1035	160	53	42	340	374	1640	850	72	465	71	632	55				
184	1895	1111	83	1095	160	53	42	340	374	1760	850	72	525	71	632	55				
194...224	Talep edildiğinde / On request / Auf Anfrage																			

#) Max ölçülerdir. Ayrıntılara siparişte gönderilen dokümanlardan ulaşılabilir.

Ölçüler mm'dir.

1) Şaftlar:

m6 ≤ Ø100; n6 > Ø100

Kama kanalı DIN 6885/1,

Kama kanalı genişliği ISO JS9 a göre

Kama DIN 6885/1 form B

Ayrıntılar için sayfa 127-136'ya bakılabilir.

4) Pompa borusu ve koruyucusunun gerçek ölçülerinin boşluğu için Lütfen PGR'ye danışınız

5) Şaft montajlı redüktörler için A, D ve G montajı istendiğinde

*) Yaklaşık değerlerdir. Kesin verilere siparişte gönderilen dokümanlardan ulaşılabilir.

***) Redüktörler yağsızdır.

#) Max. dimensions; details acc. to order-related documentation.

Dimensions in mm

1) Shafts:

m6 ≤ Ø100; n6 > Ø100

Keyway acc. to DIN 6885/1,

Hub keyway width acc. to ISO JS9

Parallel key acc. to DIN 6885/1 form B

For details, see pages 127-136

4) Space for pump pipes and cover; for exact dimensions, please refer to us.

5) For shaft-mounted gear units, designs A, D and G on request.

*) Approximate values; exact data acc. to order related documentation.

***) Without oil filling

#) Max. Abmessungen; Einzelheiten nach auftragsbezogener

Dokumentation.

Abmessungen in mm

1) Wellen:

m6 ≤ Ø100; n6 > Ø100

Passfedermut nach DIN 6885/1

Nabennutbreite nach ISO JS9

Passfeder nach DIN 6885/1 Form B

Einzelheiten siehe Seiten 127-136

4) Freiraum für Pumpe, Rohre und Deckel genaue Maße ggf. anfragen.

5) Ausführungen A, D und G bei Aufsteckausführungen auf Anfrage.

*) Richtwerte; genaue Angaben nach auftragsbezogener

Dokumentation.

***) ohne Ölfüllung

TR DÖRT KADEMELİ - DİKEY

EN FOUR STAGE - VERTICAL

DE VIERSTUFIG - VERTIKAL

	<p>PH134-SV ... PH224-SV Mil Çıkışlı Solid shaft Vollwelle</p>		Ød2	l2	G2
		134	200	350	335
		144	210	350	335
		154	230	410	380
		164	240	410	380
		174	250	410	415
		184	270	470	415
		194 204 214 224	Talep edildiğinde On request Auf Anfrage		

	<p>PH134-HV ... PH224-HV Delik millî Hollow shaft Hohlwelle</p>		ØD2	G4
		134	190	335
		144	210	335
		154	230	380
		164	240	380
		174	250	415
		184	275	415
		194 204 214 224	Talep edildiğinde On request Auf Anfrage	

	<p>5) PH134-DV ... PH224-DV Konik Sıktırmalı Hollow shaft for shrink disk Hohlwelle für schrumpfscheibe</p>		ØD2	D3	G4	G5
		134	190	195	335	480
		144	210	215	335	480
		154	230	235	380	550
		164	240	245	380	550
		174	250	260	415	600
		184	280	285	415	600
		194 204 214 224	Talep edildiğinde On request Auf Anfrage			

	<p>PH134-KV ... PH224-KV Spline DIN 5480 Hollow shaft with involute splines acc. to DIN 5480 Hohlwelle mit Zahnradprofil nach DIN 5480</p>		N / DIN 5480		ØD2	ØD3	G4
		134	N 190x5x30x36x9H		180	195	335
		144	N 190x5x30x36x9H		180	215	335
		154	N 220x5x30x42x9H		210	235	380
		164	N 220x5x30x42x9H		210	245	380
		174	N 250x5x30x48x9H		240	260	415
		184	N 250x5x30x48x9H		240	285	415
		194 204 214 224	Talep edildiğinde On request Auf Anfrage				

	<p>PH134-FV ... PH224-FV Flanşlı şaft Flanged shaft Flanschelle</p>		c	Ød2	ØD3	Øk2	nxØs	t	G7
		134	48	580	310	500	20 x 33	14	480
		144	48	620	310	540	24 x 33	14	480
		154	55	710	360	630	28 x 33	17	550
		164	55	740	360	660	30 x 33	17	550
		174	60	750	410	660	24 x 39	18	600
		184	60	800	410	710	26 x 39	18	600
		194 204 214 224	Talep edildiğinde On request Auf Anfrage						

Gövde Size Größe	Yağ miktarı Oil quantity Ölmenge (l) *)	Ağırlık / Weight Gewicht (kg) *)**)		
		SV HV DV KV	FV	
134	140	2280	2440	
144	160	2615	2785	
154	220	3460	3700	
164	230	3760	4015	
174	280	4475	4775	
184	300	4950	5300	
194...224	Talep edildiğinde On request / Auf Anfrage			

HELİSEL DİŞLİLİ REDÜKTÖRLER / HELICAL GEAR UNITS / STIRNRADGETRIEBE

İki kademe, Dikey / Double stage, Vertical / Zweistufig, Vertikal - PH42-V ... 122-V									(1),(2)
A	B	C	D	E	F	G	H	I	
İki kademe, Dikey / Double stage, Vertical / Zweistufig, Vertikal - PH132-V ... 222-V									(1),(2)
A	B	C	D	E	F	G	H	I	
Üç kademe, Dikey / Three stage, Vertical / Dreistufig, Vertikal - PH53-V ... 123-V									(1),(2)
A	B	C	D	E	F	G	H	I	
Üç kademe, Dikey / Three stage, Vertical / Dreistufig, Vertikal - PH133-V ... 223-V									(1),(2)
A	B	C	D	E	F	G	H	I	
Dört kademe, Dikey / Four stage, Vertical / Vierstufig, Vertikal - PH74-H ... 124-H									(1)
A	B	C	D	E	F	G	H	I	
Dört kademe, Dikey / Four stage, Vertical / Vierstufig, Vertikal - PH134-H ... 224-H									(1)
A	B	C	D	E	F	G	H	I	

1) Değişkenler:

G,H ve I dizaynları için flanşlı pompa uygulaması yapılamaz.

2) Soğutma serpantini

A,C ve E dizaynları için basınçlı yağlama ile flanşlı pompa birlikte uygulanamaz.

Motor pompası ile basınçlı yağlama istek üzerine yapılmaktadır.

1) Varianten:

Flanged-on pump not possible with G,H and I designs.

2) Cooling coil:

For A,C and E designs, forced lubrication by flanged-on pump not possible
Combination with forced lubrication by motor pump on request.

1) Varianten:

Flanschpumpe nicht in Verbindung mit Ausführung G,H und I

2) Kühlschlange:

Ausführungen A,C und E mit Druckschmierung durch Flanschpumpe nicht möglich.
Kombination mit Druckschmierung durch Motorpumpe auf Anfrage



Motorlu pompa
Motor pump
Motorpumpe

PH53-V ... 223-V
PH74-V ... 224-V

Yağ tankı
Oil compensating tank
Ölausgleichsbehälter

PH42-V ... 122-V
PH53-V ... 123-V
PH74-V ... 124-V

Flanşlı pompa
Flanged-on pump
Flanschpumpe

PH42-V ... 222-V
PH53-V ... 223-V
PH74-V ... 124-V

Ölçü Tabloları

Dimension Tables

Größe Tabellen

PB...

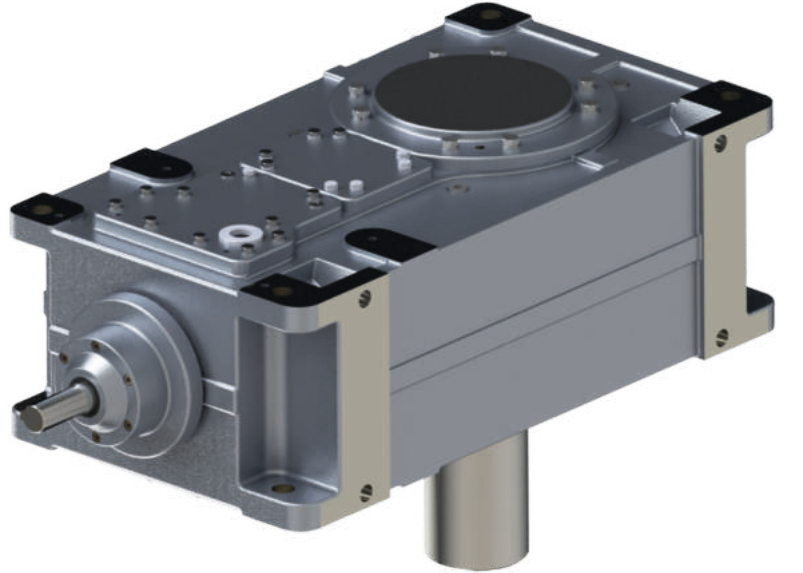

İKİ KADEME / DOUBLE STAGE / ZWEISTUFIG

ÜÇ KADEME / THREE STAGE / DREISTUFIG

DÖRT KADEME / FOUR STAGE / VIERSTUFIG

PB SERİSİ / DIKEY
PB SERIES / VERTICAL
PB SERIE / VERTIKAL

TR

İKİ KADEMELİ - DİKEY

EN

TWO STAGE - VERTICAL

DE

ZWEISTUFIG - VERTIKAL

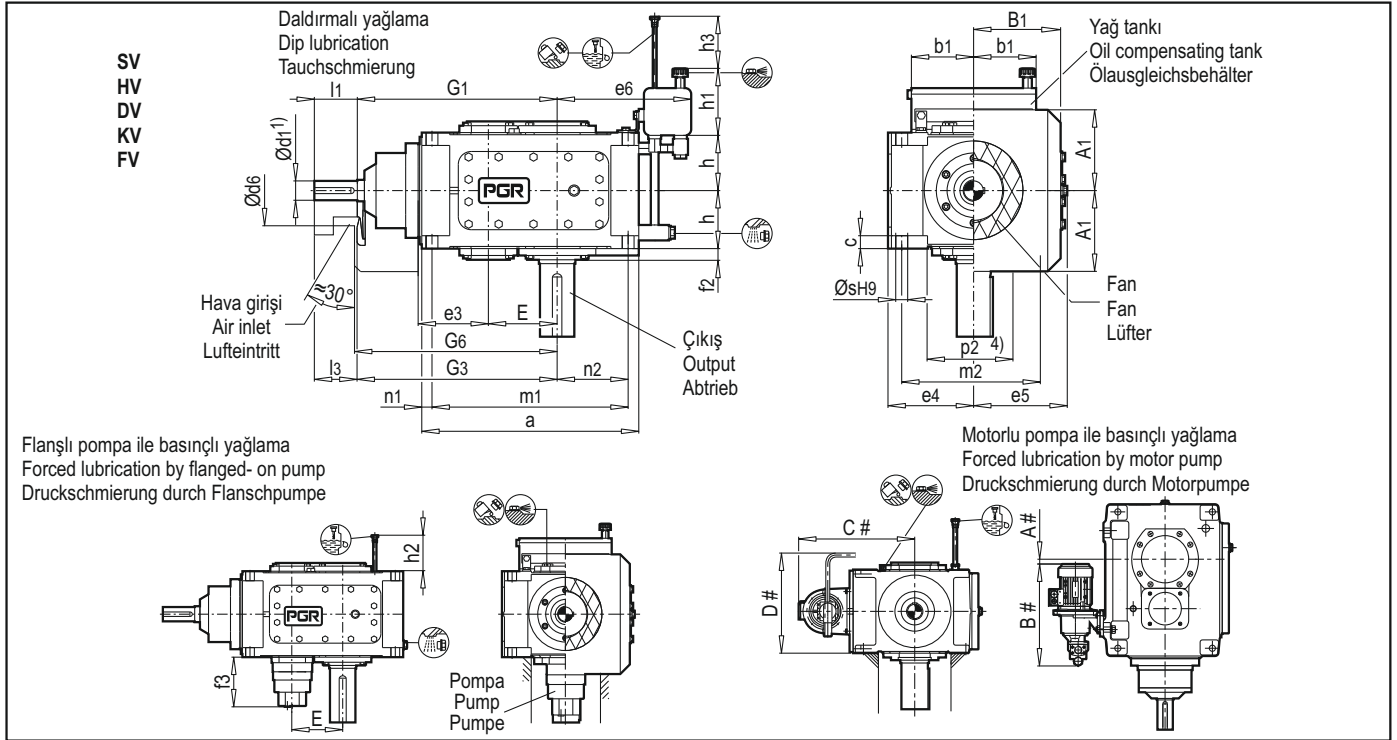

Gövde Size Größe	Giriş / Input / Antrieb						Fan / Fan / Lüfter				
	Ød1	İN = 5 - 11.2		İN = 6.3 - 14			G1	G3	A1	B1	Ød6
		l1	l3	Ød1	l1	l3					
42	45	100	80	-	-	-	465	485	190	202	150
52	55	110	80	-	-	-	535	565	217	237	160
62	-	-	-	55	110	80	570	600	217	237	160
72	70	135	105	-	-	-	640	670	252	287	210
82	-	-	-	70	135	105	685	715	252	287	210
92	80	165	130	-	-	-	755	790	272	327	195
102	-	-	-	80	165	130	805	840	272	327	195
112	90	165	130	-	-	-	925	960	330	387	210
122	-	-	-	90	165	130	995	1030	330	387	210

Gövde Size Größe	Redüktörler / Gear Units / Zahnradgetriebe																			Motor pompası Motor pump Motorpumpe					
	a	b1	c	E	e3	e4	e5	e6	f2	Pompa Pump Pumpe f3	G6	h	h1	h2	h3	m1	m2	n1	n2	p2	Øs	A #	B #	C #	D #
42	509	151	31	160	100	200	215	325	26	-	495	135	165	-	180	445	300	32	160	222	24	Talep edildiğinde On request Auf Anfrage			
52	569	241	31	185	185	230	252	390	30	195	575	160	205	245	240	505	360	32	175	272	24				
62	649	241	31	220	185	230	252	430	30	195	610	160	205	245	240	585	360	32	220	272	24				
72	694	241	37	225	225	280	302	430	32	205	685	190	205	220	250	620	430	37	215	332	28				
82	799	241	37	270	225	280	302	490	32	205	730	190	205	220	250	725	430	37	275	332	28				
92	824	331	47	265	265	320	342	565	45	205	805	220	275	250	330	740	490	42	260	372	36				
102	924	331	47	315	265	320	342	615	45	205	855	220	275	250	330	840	490	42	310	372	36				
112	979	331	56	320	320	380	410	600	47	205	980	265	275	300	340	875	600	52	295	442	40				
122	1134	331	56	390	320	380	410	685	47	205	1050	265	275	300	340	1030	600	52	380	442	40				

#) Max ölçülerdir. Ayrıntılara siparişte gönderilen dokümanlardan ulaşılabilir.
Ölçüler mm'dir.

- 1) **Şaftlar:**
m6≤Ø100; n6>Ø100
Kama kanalı DIN 6885/1,
Kama kanalı genişliği ISO JS9 a göre
Kama DIN 6885/1 form B
Ayrıntılar için sayfa 127-136'ya bakılabilir.

3) **Soğutma serpantini:**
A,C ve E dizaynları için Flanşlı pompa ile basınçlı yağlama mümkün değildir.
Motor pompası ile basınçlı yağlama istek üzerine yapılmaktadır.

4) Pompa borusu ve koruyucusunun gerçek ölçülerinin boşluğu için lütfen PGR'ye danışınız.

5) Şaft montajlı redüktörler için A, D ve G montajı istek üzerine yapılmaktadır.

*) Yaklaşık değerlerdir. Kesin verilere siparişte gönderilen dokümanlardan ulaşılabilir.

** Redüktörler yağsızdır.

#) Max. dimensions; details acc. to order-related documentation.
Dimensions in mm

- 1) **Shafts:**
m6≤Ø100; n6>Ø100
Keyway acc.to DIN 6885/1,
Hub keyway width acc.to ISO JS9
Parallel key acc.to DIN 6885/1 form B
For details, see pages 127-136

3) **Cooling coil:**
For A,C and E designs, forced lubrication by flanged-on pump not possible
Combination with forced lubrication by motor pump on request

4) Space for pump pipes and cover; for exact dimensions, please refer to us.

5) For shaft-mounted gear units, designs A,D and G on request.

*) Approximate values; exact data acc. to order related documentation.

** Without oil filling

#) Max. Abmessungen; Einzelheiten nach auftragsbezogener Dokumentation.
Abmessungen in mm

- 1) **Wellen:**
m6≤Ø100; n6>Ø100
Passfedernut nach DIN 6885/1
Nabennutbreite nach ISO JS9
Passfeder nach DIN 6885/1 Form B
Einzelheiten siehe Seiten 127-136

3) **Kühlschlange:**
Ausführungen A, C und E mit Druckschmierung durch Flanschpumpe nicht möglich.
Kombination mit Druckschmierung durch Motorpumpe auf Anfrage.

4) Freiraum für Pumpe, Rohre und Deckel genaue Maße ggf. anfragen.

5) Ausführungen A, D und G bei Aufsteckausführungen auf Anfrage.

*) Richtwerte; genaue Angaben nach auftragsbezogener Dokumentation.

** ohne Ölfüllung

TR

İKİ KADEMELİ - DİKEY

EN

TWO STAGE - VERTICAL

DE

ZWEISTUFIG - VERTIKAL

	<p>PB42-SV ... PB122-SV Mil Çıkışlı Solid shaft Vollwelle</p>		Ød2	l2	G2
		42	80	170	170
		52	100	210	200
		62	110	210	200
		72	120	210	235
		82	130	250	235
		92	140	250	270
		102	160	300	270
112	170	300	320		
122	180	300	320		

	<p>PB42-HV ... PB122-HV Delik milli Hollow shaft Hohlwelle</p>		ØD2	G2
		42	80	170
		52	95	200
		62	105	200
		72	115	235
		82	125	235
		92	135	270
		102	150	270
112	165	320		
122	180	320		

	<p>PB42-DV ... PB122-DV Konik Sıkırtmalı Hollow shaft for shrink disk Hohlwelle für schrumpfscheibe</p>	5)		ØD2	ØD3	G4	G5
		42	85	85	170	235	
		52	100	100	200	275	
		62	110	110	200	275	
		72	120	120	235	320	
		82	130	130	235	325	
		92	140	145	270	365	
		102	150	155	270	385	
112	165	170	320	450			
122	180	185	320	455			

	<p>PB42-KV ... PB122-KV Spline DIN 5480 Hollow shaft with involute splines acc. to DIN 5480 Hohlwelle mit Zahnradprofil nach DIN 5480</p>		N / DIN 5480	ØD2	ØD3	G4
		42	-	-	-	
		52	N 95x3x30x30x9H	89	100	200
		62	N 95x3x30x30x9H	89	110	200
		72	N 120x3x30x38x9H	114	120	235
		82	N 120x3x30x38x9H	114	130	235
		92	N 140x3x30x45x9H	134	145	270
		102	N 140x3x30x45x9H	134	155	270
112	N 170x5x30x32x9H	160	170	320		
122	N 170x5x30x32x9H	160	185	320		

	<p>PB42-FV ... PB122-FV Flanşlı şaft Flanged shaft Flanschswelle</p>		c	Ød2	ØD3	Øk2	nxØs	t	G7
		42	-	-	-	-	-	-	
		52	25	300	150	260	16 x 22	10	290
		62	25	320	160	280	18 x 22	10	290
		72	30	370	180	320	16 x 26	10	340
		82	30	390	190	340	18 x 26	10	340
		92	38	430	220	380	20 x 26	12	385
		102	38	470	240	420	22 x 26	12	385
112	42	510	260	450	18 x 33	12	450		
122	42	540	280	480	22 x 33	12	450		

Gövde Size Größe	Yağ miktarı Oil quantity / Ölmenge (l)*)		Ağırlık / Weight Gewicht (kg) **)**)		Soğutma serpantini / Cooling coil / Kühlschlange 3) Soğutma serpantini su bağlantısı G1/2" Water connection for cooling coil G1/2" Wasseranschluß für Kühlschlange G1/2"	Gövde Size Größe	m6	n6	e8	l/(min x)
	Daldırmalı yağlama Dip lubrication Tauch- schmierung	Basınçlı yağlama Forced lubrication Druck- schmierung	SV HV DV KV	FV						
42	23.5	-	240	-		42	90	141	157	4
52	38	19	365	405		52	100	165	169	8
62	46	23	415	460		62	100	165	214	4
72	74	37	620	675		72	100	203	208	8
82	81	40	710	770		82	100	203	266	4
92	115	57	1015	1105		92	130	245	246	8
102	120	60	1170	1265		102	130	245	294	8
112	190	95	1660	1795		112	140	290	275	8
122	225	114	1930	2080		122	140	290	360	8

x) Gereki soğutma suyu miktarı;
basıncı 8 bar
Cooling water quantity required;
max. cooling water pressure: 8 bar
Erforderliche Kühlwassermenge,
max. Kühlwasserdruck: 8 bar

TR

İKİ KADEMELİ - DİKEY

EN

TWO STAGE - VERTICAL

DE

ZWEISTUFIG - VERTIKAL

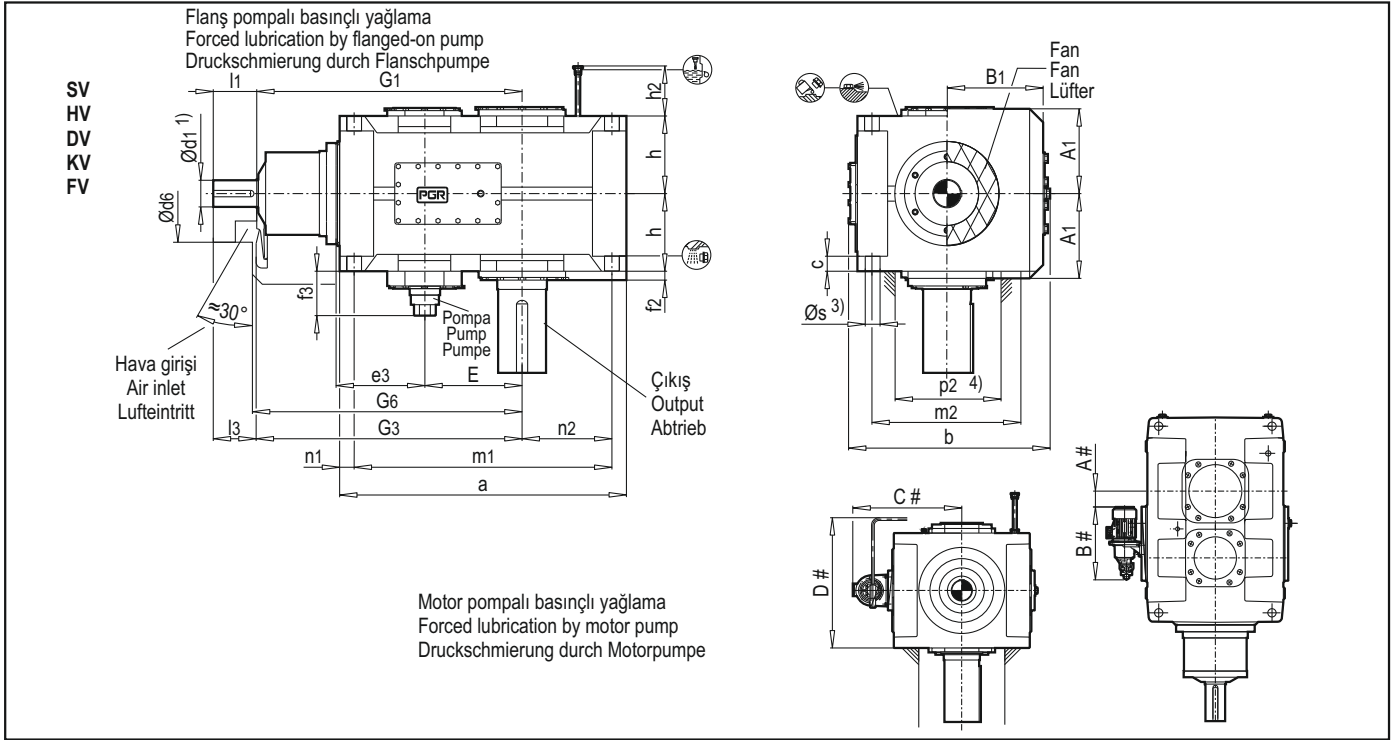

Gövde Size Größe	Giriş / Input / Antrieb															Fan / Fan / Lüfter				
	İN = 5 - 11.2			İN = 5.6 - 11.2			İN = 6.3 - 14			İN = 5.6 - 12.5			İN = 7.1 - 12.5			G1	G3	A1	B1	Ød6
	Ød1	l1	l3	Ød1	l1	l3	Ød1	l1	l3	Ød1	l1	l3	Ød1	l1	l3					
132	110	205	165	-	-	-	-	-	-	-	-	-	-	-	-	1070	1110	377	452	245
142	-	-	-	-	-	-	110	205	165	-	-	-	-	-	-	1140	1180	377	452	245
152	130	245	200	-	-	-	-	-	-	-	-	-	-	-	-	1277	1322	437	497	280
162	-	-	-	-	-	-	-	-	-	130	245	200	-	-	-	1323	1368	437	497	280
172	-	-	-	150	245	200	-	-	-	-	-	-	-	-	-	1435	1480	507	557	380
182	-	-	-	-	-	-	-	-	-	-	-	-	150	245	200	1495	1540	507	557	380

Gövde Size Größe	Redüktörler / Gear Units / Zahnradgetriebe															Motor Pompası Motor pump / Motorpumpe					
	a	b	c	E	e3	f2	Pompa Pump Pumpe f3	G6	h	h2	m1	m2	n1	n2	p2	Øs	A #	B #	C #	D #	
132	1134	901	63	370	370	38	205	1130	325	350	1035	680	52	360	502	48	Talep edildiğinde On request Auf Anfrage				
142	1274	901	63	440	370	45	205	1200	325	350	1175	680	52	430	502	48					
152	1354	981	74	442	442	75	205	1340	380	430	1235	750	62	430	572	55					
162	1444	981	74	488	442	75	205	1385	380	430	1325	750	62	475	572	55					
172	1494	1111	83	490	490	98	205	1500	437.5	480	1360	840	72	465	632	65					
182	1614	1111	83	550	490	98	205	1560	437.5	480	1480	840	72	525	632	65					

#) Max ölçülerdir. Ayrıntılara siparişte gönderilen dökümanlardan ulaşılabilir.
Ölçüler mm'dir.

1) **Şaftlar:**
n6>Ø100

Kama kanalı DIN 6885/1,
Kama kanalı genişliği ISO JS9 a göre
Kama DIN 6885/1 form B
Ayrıntılar için sayfa 127-136'ya bakılabilir.

3) **Soğutma serpantini:**

C, D ve F dizaynları için Flanşlı pompa ile basınçlı yağlama mümkün değildir.
Motor pompası ile basınçlı yağlama istek üzerine yapılmaktadır.

4) Pompa borusu ve koruyucusunun gerçek ölçülerinin boşluğu için lütfen PGR'ye danışınız.

5) Şaft montajı redüktörler için A ve D montajı istek üzerine yapılmaktadır.

*) Yaklaşık değerlerdir. Kesin verilere siparişte gönderilen dökümanlardan ulaşılabilir.

** Redüktörler yağsızdır.

#) Max. dimensions; details acc. to order-related documentation.
Dimensions in mm

1) **Shafts:**
n6>Ø100

Keyway acc.to DIN 6885/1,
Hub keyway width acc.to ISO JS9
Parallel key acc.to DIN 6885/1 form B
For details, see pages 127-136

3) **Cooling coil:**

For C, D and F designs, forced lubrication by flanged-on pump not possible
Combination with forced lubrication by motor pump on request

4) Space for pump pipes and cover; for exact dimensions, please refer to us.

5) For shaft-mounted gear units, designs A, and D on request.

*) Approximate values; exact data acc. to order related documentation.

** Without oil filling

#) Max. Abmessungen; Einzelheiten nach auftragsbezogener Dokumentation.

Abmessungen in mm

1) **Wellen:**
n6>Ø100

Passfedernut nach DIN 6885/1
Nabennutbreite nach ISO JS9
Passfeder nach DIN 6885/1 Form B
Einzelheiten siehe Seiten 127-136

3) **Kühlschlange:**

Ausführungen C, D und F mit Druckschmierung durch Flanschpumpe nicht möglich.
Kombination mit Druckschmierung durch Motorpumpe auf Anfrage.

4) Freiraum für Pumpe, Rohre und Deckel genaue Maße ggf. anfragen.

5) Ausführungen A und D bei Aufsteckausführungen auf Anfrage.

*) Richtwerte; genaue Angaben nach auftragsbezogener Dokumentation.

** ohne Ölfüllung

TR İKİ KADEMELİ - DİKEY

EN TWO STAGE - VERTICAL

DE ZWEISTUFIG - VERTIKAL

	<p>PB132-SV ... PB182-SV Mil Çıkışlı Solid shaft Vollwelle</p>		Ød2	l2	G2
		132	200	350	390
		142	210	350	390
		152	230	410	460
		162	240	410	460
		172	250	410	540
182	270	470	540		

	<p>PB132-HV ... PB182-HV Delik milli Hollow shaft Hohlwelle</p>		ØD2	G4
		132	-	-
		142	210	390
		152	-	-
		162	240	450
		172	-	-
182	275	510		

	<p>5) PB132-DV ... PB182-DV Konik Sıkırmalı Hollow shaft for shrink disk Hohlwelle für schrumpfscheibe</p>		ØD2	ØD3	G4	G5
		132	-	-	-	-
		142	210	215	390	535
		152	-	-	-	-
		162	240	245	450	620
		172	-	-	-	-
182	280	285	510	700		

	<p>PB132-KV ... PB182-KV Spline DIN 5480 Hollow shaft with involute splines acc. to DIN 5480 Hohlwelle mit Zahnradprofil nach DIN 5480</p>		N / DIN 5480		ØD2	ØD3	G4
		132	-	-	-	-	
		142	N 190x5x30x36x9H		180	215	390
		152	-	-	-	-	
		162	N 220x5x30x42x9H		210	245	450
		172	-	-	-	-	
182	N 250x5x30 x48x9H		240	285	510		

	<p>PB132-FV ... PB182-FV Flanşlı şaft Flanged shaft Flanschelle</p>		c	Ød2	ØD3	Øk2	nxØs	t	G7
		132	48	580	310	500	20 x 33	14	525
		142	48	620	310	540	24 x 33	14	525
		152	55	710	360	630	28 x 33	17	625
		162	55	740	360	660	30 x 33	17	625
		172	60	750	410	660	24 x 39	18	695
182	60	800	410	710	26 x 39	18	695		

Gövde Size GröÙe	Yağ miktarı Oil quantity Ölmenge (l)*	Ağırlık / Weight Gewicht (kg)***)		Soğutma serpantini / Cooling coil / Kùhlschlange 3)	Gövde Size GröÙe	m6	n6	e8	l/min x)
		SV HV DV KV	FV						
132	125	2360	2530	<p>Soğutma serpantini su bağlantısı G1/2" Water connection for cooling coil G1/2" Wasseranschluß für Kùhlschlange G1/2"</p> <p>Çıkış Output Abtrieb</p> <p>Soğutma sistemi deniz suyu ve acı su için uygundur Cooling coil suitable for fresh, sea and brackish water Kùhlschlange geeignet für SüÙ-, See- und Brackwasser</p>	132	324	300	335	8
142	140	2740	2920		142	324	300	405	8
152	190	3820	4075		152	396	345	390	8
162	200	4185	4455		162	396	345	435	8
172	270	5360	5680		172	324	395	425	8
182	295	5900	6270		182	324	395	485	8

x) Gereklì soğutma suyu miktarı; basıncı 8 bar
Cooling water quantity required; max. cooling water pressure: 8 bar
Erforderliche Kùhlwassermenge; max. Kùhlwasserdruck: 8 bar

TR

ÜÇ KADEMELİ - DİKEY

EN

THREE STAGE - VERTICAL

DE

DREISTUFIG - VERTIKAL

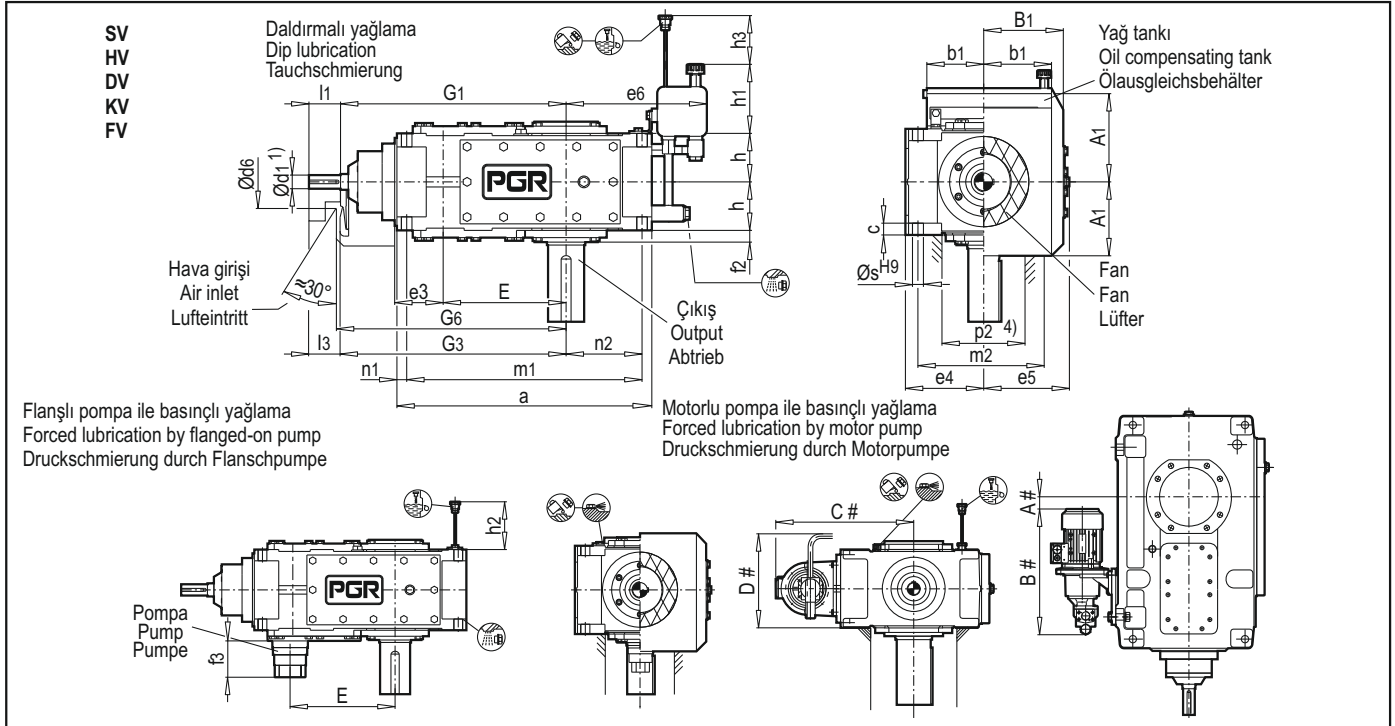

Gövde Size Größe	Giriş / Input / Antrieb												Fan / Fan / Lüfter			
	İN = 12.5 - 45			İN = 50 - 71			İN = 16 - 56			İN = 63 - 90			G1	G3	A1	B1
Ød1	l1	l3	Ød1	l1	l3	Ød1	l1	l3	Ød1	l1	l3	G1	G3	A1	B1	Ød6
43	30	70	50	25	60	40	-	-	-	-	-	500	520	145	202	110
53	35	80	60	28	60	40	-	-	-	-	-	575	595	170	237	130
63	-	-	-	-	-	-	35	80	60	28	60	610	630	170	237	130
73	45	100	80	35	80	60	-	-	-	-	-	690	710	195	277	165
83	-	-	-	-	-	-	45	100	80	35	80	735	755	195	277	165
93	55	110	80	40	100	70	-	-	-	-	-	800	830	233	327	175
103	-	-	-	-	-	-	55	110	80	40	100	850	880	233	327	175
113	70	135	105	50	110	80	-	-	-	-	-	960	990	265	387	190
123	-	-	-	-	-	-	70	135	105	50	110	1030	1060	265	387	190

Gövde Size Größe	Redüktörler / Gear Units / Zahnradgetriebe																		Motor pompa / Motor Pump / Motor pumpe						
	a	b1	c	E	e3	e4	e5	e6	f2	Pompa Pump Pumpe f3	G6	h	h1	h2	h3	m1	m2	n1	n2	p2	Øs	A #)	B #)	C #)	D #)
43	569	151	31	270	110	200	215	325	22	-	530	107.5	165	-	180	505	300	32	160	222	24	Talep edildiğinde On request Auf Anfrage			
53	644	241	31	315	130	230	252	390	28	195	605	127.5	205	180	240	580	360	32	175	272	24				
63	724	241	31	350	130	230	252	430	28	195	640	127.5	205	180	240	660	360	32	220	272	24				
73	789	241	37	385	160	280	292	430	30	195	720	150	205	165	250	715	430	37	215	332	28				
83	894	241	37	430	160	280	302	490	32	195	765	150	205	165	250	820	430	37	275	332	28				
93	929	331	47	450	185	320	342	565	32	185	845	185	275	205	330	845	490	42	260	372	36				
103	1029	331	47	500	185	320	342	615	32	185	895	185	275	205	330	945	490	42	310	372	36				
113	1109	331	56	545	225	380	402	600	35	185	1010	215	275	240	340	1005	600	52	295	442	40				
123	1264	331	56	615	225	380	410	685	35	185	1080	215	275	240	340	1160	600	52	380	442	40				

#) Max ölçülerdir. Ayrıntılara siparişte gönderilen dökümanlardan ulaşılabilir. Ölçüler mm'dir.

1) Şaftlar:

k6=Ø25; Ø28≤m6≤Ø100; n6>Ø100

Kama kanalı DIN 6885/1.

Kama kanalı genişliği ISO JS9'a göre

Kama DIN 6885/1 form B

Ayrıntılar için sayfa 127-136'ya bakılabilir.

3) Soğutma serpantini:

A, B ve E dizaynları için Flanşlı pompa ile basınçlı yağlama mümkün değildir.

Motor pompası ile basınçlı yağlama istek üzerine yapılmaktadır.

4) Pompa borusu ve koruyucusunun gerçek ölçülerinin boşluğu için lütfen PGR'ye danışınız.

5) Şaft montajlı redüktörler için A ve D montajı istek üzerine yapılmaktadır.

*) Yaklaşık değerlerdir. Kesin verilere siparişte gönderilen dökümanlardan ulaşılabilir.

** Redüktörler yağsızdır.

#) Max. dimensions; details acc. to order-related documentation. Dimensions in mm

1) Shafts:

k6=Ø25; Ø28≤m6≤Ø100; n6>Ø100

Keyway acc.to DIN 6885/1,

Hub keyway width acc.to ISO JS9

Parallel key acc.to DIN 6885/1 form B

For details, see pages 127-136.

3) Cooling coil:

For A, B and E designs, forced lubrication by flanged-on pump not possible

Combination with forced lubrication by motor pump on request

4) Space for pump pipes and cover; for exact dimensions, please refer to us.

5) For shaft-mounted gear units, designs A and D on request.

*) Approximate values; exact data acc. to order related documentation.

** Without oil filling

#) Max. Abmessungen; Einzelheiten nach auftragsbezogener Dokumentation.

Abmessungen in mm

1) Wellen:

k6=Ø25; Ø28≤m6≤Ø100; n6>Ø100

Passfedernach DIN 6885/1

Nabennutbreite nach ISO JS9

Passfeder nach DIN 6885/1 Form B

Einzelheiten siehe Seiten 127-136

3) Kühlschlange:

Ausführungen A, B und E mit Druckschmierung durch Flanschpumpe nicht möglich.

Kombination mit Druckschmierung durch Motorpumpe auf Anfrage.

4) Freiraum für Pumpe, Rohre und Deckel genaue Maße ggf. anfragen.

5) Ausführungen A und D bei Aufsteckausführungen auf Anfrage.

*) Richtwerte; genaue Angaben nach auftragsbezogener Dokumentation.

** ohne Ölfüllung

TR

ÜÇ KADEMELİ - DİKEY

EN

THREE STAGE - VERTICAL

DE

DREISTUFIG - VERTIKAL

	<p>PB43-SV ... PB123-SV Mil Çıkışlı Solid shaft Vollwelle</p>		Ød2	l2	G2
		43	80	170	140
		53	100	210	165
		63	110	210	165
		73	120	210	195
		83	130	250	195
		93	140	250	235
		103	160	300	235
		113	170	300	270
123	180	300	270		

	<p>PB43-HV ... PB123-HV Delik milli Hollow shaft Hohlwelle</p>		ØD2	G4
		43	80	140
		53	95	165
		63	105	165
		73	115	195
		83	125	195
		93	135	235
		103	150	235
		113	165	270
123	180	270		

	<p>PB43-DV ... PB123-DV Konik Sıktırmalı Hollow shaft for shrink disk Hohlwelle für schrumpfscheibe</p>	5)	ØD2	ØD3	G4	G5
		43	85	85	140	205
		53	100	100	165	240
		63	110	110	165	240
		73	120	120	195	280
		83	130	130	195	285
		93	140	145	235	330
		103	150	155	235	350
		113	165	170	270	400
123	180	185	270	405		

	<p>PB43-KV ... PB123-KV Spline DIN 5480 Hollow shaft with involute splines acc. to DIN 5480 Hohlwelle mit Zahnradprofil nach DIN 5480</p>		N / DIN 5480	ØD2	ØD3	G4
		43	-	-	-	-
		53	N 95x3x30x30x9H	89	100	165
		63	N 95x3x30x30x9H	89	110	165
		73	N 120x3x30x38x9H	114	120	195
		83	N 120x3x30x38x9H	114	130	195
		93	N 140x3x30x45x9H	134	145	235
		103	N 140x3x30x45x9H	134	155	235
		113	N 170x5x30x32x9H	160	170	270
123	N 170x5x30x32x9H	160	185	270		

	<p>PB43-FV ... PB123-FV Flanşlı şaft Flanged shaft Flanschswelle</p>		c	Ød2	ØD3	Øk2	nxØs	t	G7
		43	-	-	-	-	-	-	-
		53	25	300	150	260	16 x 22	10	255
		63	25	320	160	280	18 x 22	10	255
		73	30	370	180	320	16 x 26	10	300
		83	30	390	190	340	18 x 26	10	300
		93	38	430	220	380	20 x 26	12	350
		103	38	470	240	420	22 x 26	12	350
		113	42	510	260	450	18 x 33	12	400
123	42	540	280	480	22 x 33	12	400		

Gövde Size Größe	Yağ miktarı / Oil quantity Ölmenge (l)*		Ağırlık / Weight Gewicht (kg)***)		Soğutma serpantini / Cooling coil / Kühlschlange				
	Daldırmalı yağlama Dip Lubrication Tauch- schmierung	Basınçlı yağlama Forced Lubrication Druck- schmierung	SV HV DV KV	FV	Gövde Size Größe	m6	n6	e8	l/min x)
43	20	10	215	-	43	90	141	157	4
53	34	17	330	365	53	100	165	169	4
63	36	18	385	425	63	100	165	214	4
73	58	29	560	610	73	100	203	208	4
83	68	34	645	700	83	100	203	266	4
93	100	50	910	995	93	130	245	246	8
103	105	52	1040	1130	103	130	245	294	8
113	160	80	1480	1610	113	140	290	275	8
123	184	92	1760	1900	123	140	290	360	8

Soğutma serpantini su bağlantısı G1/2"
Water connection for cooling coil G1/2"
Wasseranschluß für Kühlschlange G1/2"

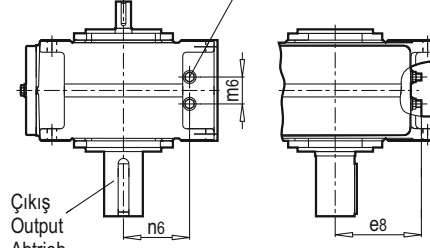

Soğutma sistemi deniz suyu ve acı su için uygundur
Cooling coil suitable for fresh, sea and brackish water
Kühlschlange geeignet für Süß-, See- und Brackwasser

x) Gerekli soğutma suyu miktarı;
basıncı 8 bar
Cooling water quantity required;
max. cooling water pressure: 8 bar
Erforderliche Kühlwassermenge,
max. Kühlwasserdruck: 8 bar

TR

ÜÇ KADEMELİ - DİKEY

EN

THREE STAGE - VERTICAL

DE

DREISTUFIG - VERTIKAL

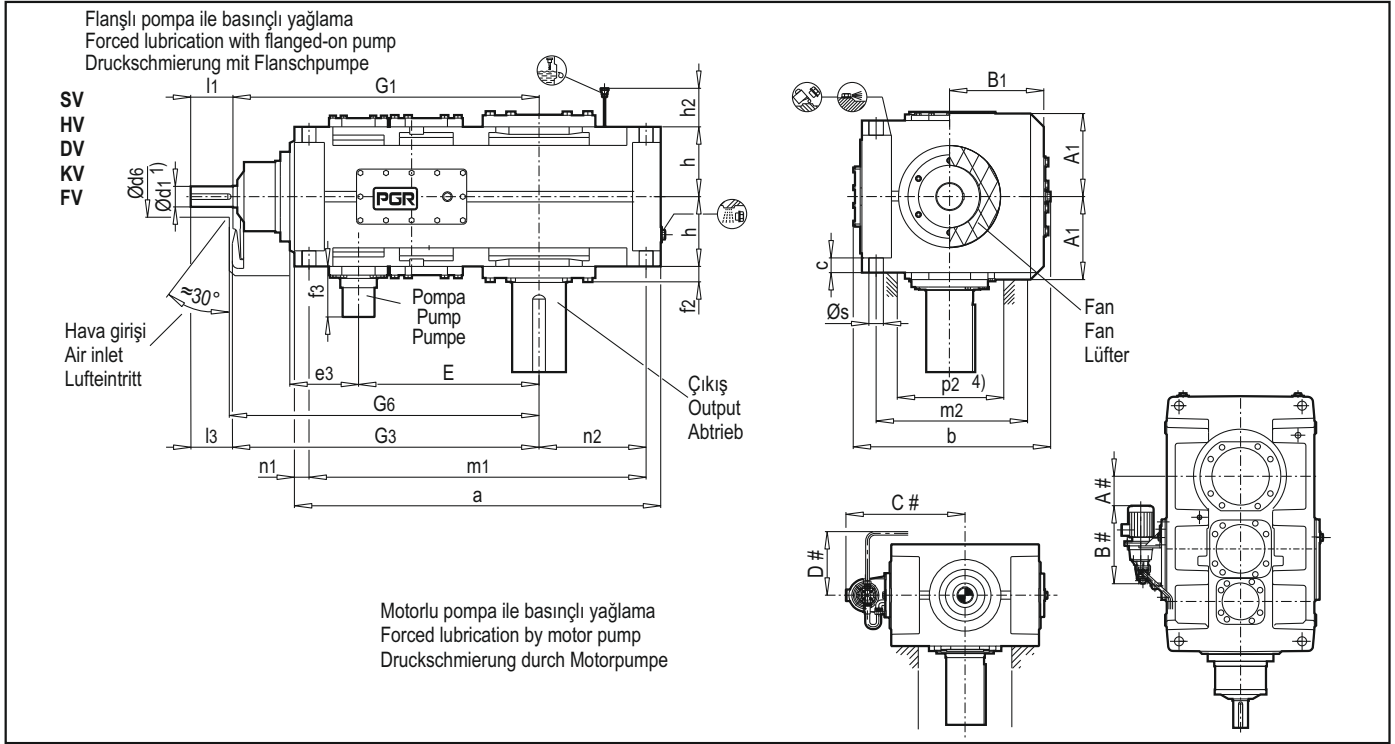

Gövde Size Größe	Giriş / Input / Antrieb															Fan / Fan / Lüfter							
	İN=12.5 - 45			İN = 50 - 71			İN =14 - 50			İN =56 - 80			İN =16 - 56			İN =63 - 90			G1	G3	A1	B1	Ød6
	Ød1	l1	l3	Ød1	l1	l3	Ød1	l1	l3	Ød1	l1	l3	Ød1	l1	l3	Ød1	l1	l3					
133	80	165	130	60	140	105	-	-	-	-	-	-	-	-	-	-	-	-	1125	1160	327	477	210
143	-	-	-	-	-	-	-	-	-	-	-	-	80	165	130	60	140	105	1195	1230	327	477	210
153	90	165	130	70	140	105	-	-	-	-	-	-	-	-	-	-	-	-	1367	1402	367	522	210
163	-	-	-	-	-	-	90	165	130	70	140	105	-	-	-	-	-	-	1413	1448	367	522	210
173	110	205	165	80	170	130	-	-	-	-	-	-	-	-	-	-	-	-	1560	1600	397	572	230
183	-	-	-	-	-	-	110	205	165	80	170	130	-	-	-	-	-	-	1620	1660	397	572	230
193...223	İstek üzerine / On request / Auf Anfrage																						

Gövde Size Größe	Redüktörler / Gear Units / Zahnradgetriebe															Motor Pompası Motor pump / Motorpumpe				
	a	b	c	E	e3	f2	Pompa Pump Pumpe f3	G6	h	h2	m1	m2	n1	n2	p2	Øs	A #	B #	C #	D #
133	1294	901	63	635	265	35	175	1180	272.5	300	1195	680	52	360	502	48	Talep edildiğinde On request Auf Anfrage			
143	1434	901	63	705	265	35	175	1250	272.5	300	1335	680	52	430	502	48				
153	1554	981	74	762	320	42	175	1420	310	340	1435	750	62	430	572	55				
163	1644	981	74	808	320	42	175	1470	310	340	1525	750	62	475	572	55				
173	1744	1111	83	860	370	42	175	1620	340	380	1610	850	72	465	632	55				
183	1864	1111	83	920	370	42	175	1680	340	380	1730	850	72	525	632	55				
193...223	Talep edildiğinde / On request / Auf Anfrage																			

#) Max ölçülerdir. Ayrıntılara siparişte gönderilen dokümanlardan ulaşılabilir.
Ölçüler mm'dir.

1) Şaftlar:

m6<=Ø100; n6>Ø100
Kama kanalı DIN 6885/1,
Kama kanalı genişliği ISO JS9 a göre
Kama DIN 6885/1 form B
Ayrıntılar için sayfa 127-136'ya bakılabilir.

3) Soğutma serpantini:

A, B ve E dizaynları için Flanşlı pompa ile basınçlı yağlama mümkün değildir.
Motor pompası ile basınçlı yağlama istek üzerine yapılmaktadır.

4) Pompa borusu ve koruyucusunun gerçek ölçülerinin boşluğu için lütfen PGR'ye danışınız.

5) Şaft montajlı redüktörler için A ve D montajı istek üzerine yapılmaktadır.

*) Yaklaşık değerlerdir. Kesin verilere siparişte gönderilen dokümanlardan ulaşılabilir.

** Redüktörler yağsızdır.

#) Max.dimensions; details acc. to order-related documentation.

Dimensions in mm

1) Shafts:

m6<=Ø100; n6>Ø100
Keyway acc.to DIN 6885/1,
Hub keyway width acc.to ISO JS9
Parallel key acc.to DIN 6885/1 form B
For details, see pages 127-136

3) Cooling coil:

For A, B and E designs, forced lubrication by flanged-on pump not possible
Combination with forced lubrication by motor pump on request

4) Space for pump pipes and cover; for exact dimensions, please refer to us.

5) For shaft-mounted gear units, designs A, and D on request.

*) Approximate values; exact data acc. to order related documentation.

** Without oil filling

#) Max. Abmessungen; Einzelheiten nach auftragsbezogener Dokumentation.

Abmessungen in mm

1) Wellen:

m6<=Ø100; n6>Ø100
Passfedernut nach DIN 6885/1
Nabennutbreite nach ISO JS9
Passfeder nach DIN 6885/1 Form B
Einzelheiten siehe Seiten 127-136

3) Kühlschlange:

Ausführungen A, B und E mit Druckschmierung durch Flanshpumpe nicht möglich.
Kombination mit Druckschmierung durch Motorpumpe auf Anfrage.

4) Freiraum für Pumpe, Rohre und Deckel genaue Maße ggf. anfragen.

5) Ausführungen A und D bei Aufsteckausführungen auf Anfrage.

*) Richtwerte; genaue Angaben nach auftragsbezogener Dokumentation.

** ohne Ölfüllung

TR

ÜÇ KADEMELİ - DİKEY

EN

THREE STAGE - VERTICAL

DE

DREISTUFIG - VERTIKAL

	<p>PB133-SV ... PB223-SV Mil Çıkışlı Solid shaft Vollwelle</p>		Ød2	l2	G2
		133	200	350	335
		143	210	350	335
		153	230	410	380
		163	240	410	380
		173	250	410	415
		183	270	470	415
		193	Talep edildiğinde		
203	On request				
213	Auf Anfrage				
223					

	<p>PB133-HV ... PB223-HV Delik millî Hollow shaft Hohlwelle</p>		ØD2	G4
		133	190	335
		143	210	335
		153	230	380
		163	240	380
		173	250	415
		183	275	415
		193	Talep edildiğinde	
203	On request			
213	Auf Anfrage			
223				

	<p>5) PB133-DV ... PB223-DV Konik Sıktırmalı Hollow shaft for shrink disk Hohlwelle für schrumpfscheibe</p>		ØD2	ØD3	G4	G5
		133	190	195	335	480
		143	210	215	335	480
		153	230	235	380	550
		163	240	245	380	550
		173	250	260	415	600
		183	280	285	415	600
		193	Talep edildiğinde			
203	On request					
213	Auf Anfrage					
223						

	<p>PB133-KV ... PB223-KV Spline DIN 5480 Hollow shaft with involute splines acc. to DIN 5480 Hohlwelle mit Zahnradprofil nach DIN 5480</p>		N / DIN 5480		ØD2	ØD3	G4
		133	N 190x5x30x36x9H		180	195	335
		143	N 190x5x30x36x9H		180	215	335
		153	N 220x5x30x42x9H		210	235	380
		163	N 220x5x30x42x9H		210	245	380
		173	N 250x5x30x48x9H		240	260	415
		183	N 250x5x30x48x9H		240	285	415
		193	Talep edildiğinde				
203	On request						
213	Auf Anfrage						
223							

	<p>PB133-FV ... PB223-FV Flanşlı shaft Flanged shaft Flanschswelle</p>		c	Ød2	ØD3	Øk2	nxØs	t	G7
		133	48	580	310	500	20 x 33	14	480
		143	48	620	310	540	24 x 33	14	480
		153	55	710	360	630	28 x 33	17	550
		163	55	740	360	660	30 x 33	17	550
		173	60	750	410	660	24 x 39	18	600
		183	60	800	410	710	26 x 39	18	600
		193	Talep edildiğinde						
203	On request								
213	Auf Anfrage								
223									

Gövde Size Größe	Yağ miktarı Oil quantity Ölmenge (l)*	Ağırlık Weight / Gewicht (kg)***)		Soğutma Serpantini / Cooling coil / Kühlschlange 3)	Gövde Size Größe	m6	n6	e8	l/(min x)
		SV HV DV KV	FV						
133	115	2275	2435		133	252	300	335	8
143	130	2630	2800		143	252	300	405	8
153	180	3560	3800		153	290	335	395	8
163	190	3785	4040		163	290	335	440	8
173	260	4790	5090		173	340	380	425	8
183	275	5275	5625		183	340	380	485	8
193	Talep edildiğinde On request / Auf Anfrage				193	Talep edildiğinde On request Auf Anfrage			
203									
213									
223									

x) Gerekli soğutma suyu miktarı; basıncı 8 bar
Cooling water quantity required; max. cooling water pressure: 8 bar
Erforderliche Kühlwassermenge, max. Kühlwasserdruck: 8 bar

TR

DÖRT KADEMELİ - DİKEY

EN

FOUR STAGE - VERTICAL

DE

VIERSTUFIG - VERTIKAL

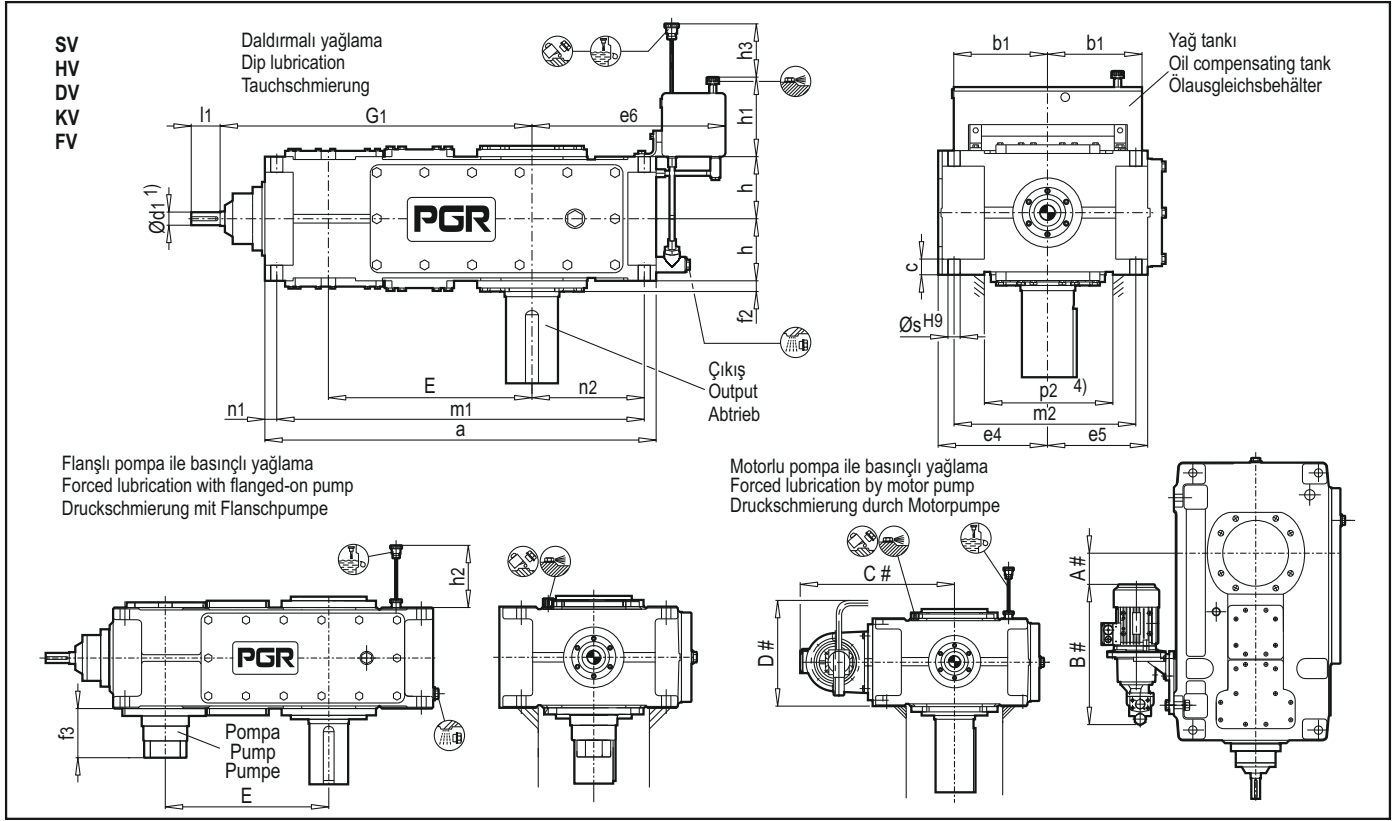

Gövde Size Größe	Giriş / Input / Antrieb								G1
	İN = 80 - 180		İN = 200 - 315		İN = 100 - 224		İN = 250 - 400		
	Ød1	l1	Ød1	l1	Ød1	l1	Ød1	l1	
54	28	55	20	50	-	-	-	-	615
64	-	-	-	-	28	55	20	50	650
74	30	70	25	60	-	-	-	-	725
84	-	-	-	-	30	70	25	60	770
94	35	80	28	60	-	-	-	-	840
104	-	-	-	-	35	80	28	60	890
114	45	100	35	80	-	-	-	-	1010
124	-	-	-	-	45	100	35	80	1080

Gövde Size Größe	a	b1	c	E	e4	e5	e6	f2	Pompa Pump Pumpe f3	h	h1	h2	h3	m1	m2	n1	n2	p2	Øs	Motor Pompası Motor pump / Motorpumpe			
																				A #)	B #)	C #)	D #)
54	694	241	31	405	230	252	390	28	205	127.5	205	190	240	630	360	32	175	272	24	Talep edildiğinde On request Auf Anfrage			
64	774	241	31	440	230	252	430	28	205	127.5	205	190	240	710	360	32	220	272	24				
74	849	241	37	495	280	292	430	30	125	150	205	165	250	775	430	37	215	332	28				
84	954	241	37	540	280	302	490	32	125	150	205	165	250	880	430	37	275	332	28				
94	1004	331	47	580	320	342	565	32	125	185	275	205	330	920	490	42	260	372	36				
104	1104	331	47	630	320	342	615	32	125	185	275	205	330	1020	490	42	310	372	36				
114	1204	331	56	705	380	402	600	35	135	215	275	240	340	1100	600	52	295	442	40				
124	1359	331	56	775	380	410	685	35	135	215	275	240	340	1255	600	52	380	442	40				

#) Max ölçülerdir. Ayrıntılara siparişte gönderilen dökümanlardan ulaşılabilir.
Ölçüler mm'dir.

1) Şaftlar:

k6=Ø25; Ø28≤m6≤Ø100; n6>Ø100

Kama kanalı DIN 6885/1,

Kama kanalı genişliği ISO JS9 a göre

Kama DIN 6885/1 form B

Ayrıntılar için sayfa 127-136'ya bakılabilir.

4) Pompa borusu ve koruyucusunun gerçek ölçülerinin boşluğu için lütfen PGR'ye danışınız.

5) Şaft montajlı redüktörler için A ve D montajı istek üzerine yapılmaktadır

*) Yaklaşık değerlerdir. Kesin verilere siparişte gönderilen dökümanlardan ulaşılabilir.

**) Redüktörler yağsızdır.

#) Max.dimensions; details acc. to order-related documentation.

Dimensions in mm

1) Shafts:

k6=Ø25; Ø28≤m6≤Ø100; n6>Ø100

Keyway acc.to DIN 6885/1,

Hub keyway width acc.to ISO JS9

Parallel key acc.to DIN 6885/1 form B

For details, see pages 127-136

4) Space for pump pipes and cover; for exact dimensions, please refer to us.

5) For shaft-mounted gear units, designs A, and D on request.

*) Approximate values; exact data acc. to order related documentation.

**) Without oil filling

#) Max. Abmessungen; Einzelheiten nach auftragsbezogener Dokumentation.
Abmessungen in mm

1) Wellen:

k6=Ø25; Ø28≤m6≤Ø100; n6>Ø100

Passfedernut nach DIN 6885/1

Nabennutbreite nach ISO JS9

Passfeder nach DIN 6885/1 Form B

Einzelheiten siehe Seiten 127-136

4) Freiraum für Pumpe, Rohre und Deckel genaue Maße ggf. anfragen.

5) Ausführungen A und D bei Aufsteckausführungen auf anfrage.

*) Richtwerte; genaue Angaben nach auftragsbezogener Dokumentation.

**) ohne Ölfüllung

TR DÖRT KADEMELİ - DİKEY

EN FOUR STAGE - VERTICAL

DE VIERSTUFIG - VERTIKAL

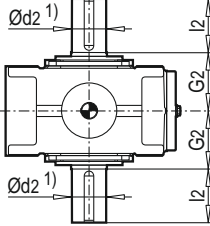
	<p>PB54-SV ... PB124-SV Mil Çıkışlı Solid shaft Vollwelle</p>		Ød2	l2	G2
		54	100	210	165
		64	110	210	165
		74	120	210	195
		84	130	250	195
		94	140	250	235
		104	160	300	235
		114	170	300	270
124	180	300	270		

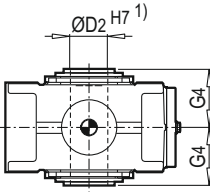
	<p>PB54-HV ... PB124-HV Delik millî Hollow shaft Hohlwelle</p>		ØD2	G4
		54	95	165
		64	105	165
		74	115	195
		84	125	195
		94	135	235
		104	150	235
		114	165	270
124	180	270		

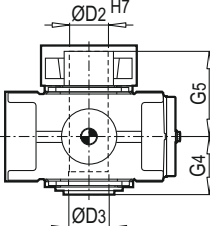
	<p>5) PB54-DV ... PB124-DV Konik Sıktırmalı Hollow shaft for shrink disk Hohlwelle für schrumpfscheibe</p>		ØD2	ØD3	G4	G5
		54	100	100	165	240
		64	110	110	165	240
		74	120	120	195	280
		84	130	130	195	285
		94	140	145	235	330
		104	150	155	235	350
		114	165	170	270	400
124	180	185	270	405		

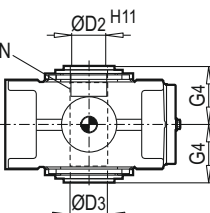
	<p>PB54-KV ... PB124-KV Spline DIN 5480 Hollow shaft with involute splines acc. to DIN 5480 Hohlwelle mit Zahnablenprofil nach DIN 5480</p>		N / DIN 5480	ØD2	ØD3	G4
		54	N 95x3x30x30x9H	89	100	165
		64	N 95x3x30x30x9H	89	110	165
		74	N 120x3x30x38x9H	114	120	195
		84	N 120x3x30x38x9H	114	130	195
		94	N 140x3x30x45x9H	134	145	235
		104	N 140x3x30x45x9H	134	155	235
		114	N 170x5x30x32x9H	160	170	270
124	N 170x5x30x32x9H	160	185	270		

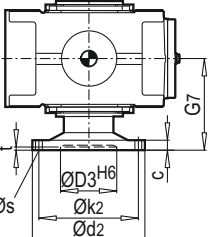
	<p>PB54-FV ... PB124-FV Flanşlı şaft Flanged shaft Flanschswelle</p>		c	Ød2	ØD3	Øk2	nxØs	t	G7
		54	25	300	150	260	16 x 22	10	255
		64	25	320	160	280	18 x 22	10	255
		74	30	370	180	320	16 x 26	10	300
		84	30	390	190	340	18 x 26	10	300
		94	38	430	220	380	20 x 26	12	350
		104	38	470	240	420	22 x 26	12	350
		114	42	510	260	450	18 x 33	12	400
124	42	540	280	480	22 x 33	12	400		

Gövde Size Größe	Yağ miktarı Oil quantity / Ölmenge (l)*		Ağırlık Weight / Gewicht (kg)**)	
	Daldırmalı yağlama Dip Lubrication Tauch- schmierung	Basınçlı yağlama Forced Lubrication Druck- schmierung	SV HV DV KV	FV
54	36	18	340	375
64	40	20	390	430
74	65	32	565	615
84	73	36	665	720
94	105	52	910	995
104	110	55	1045	1135
114	175	87	1510	1640
124	200	100	1775	1915

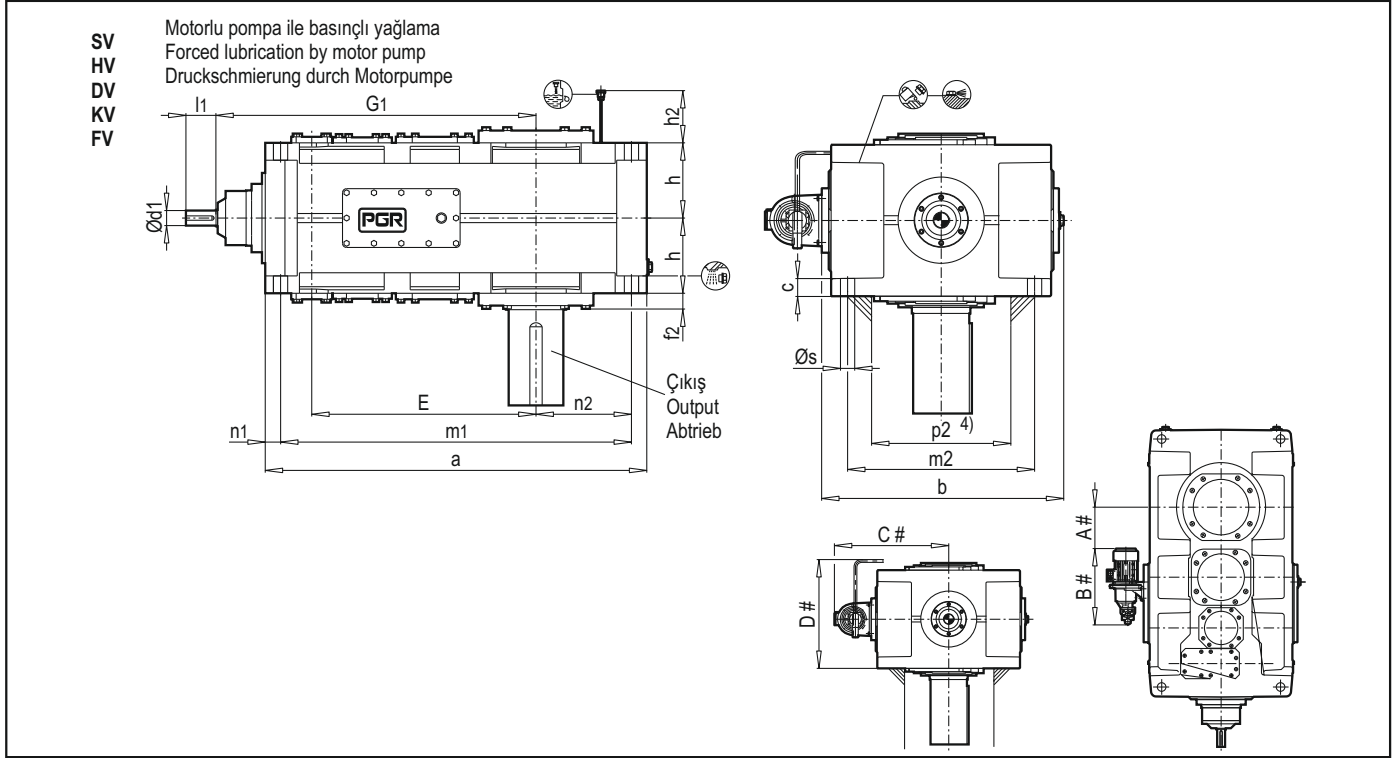

Gövde Size Größe	Giriş / Input / Antrieb												G1
	İN = 80 - 180		İN = 200 - 315		İN = 90 - 200		İN = 224 - 355		İN = 100 - 224		İN = 250 - 400		
	Ød1	l1	Ød1	l1	Ød1	l1	Ød1	l1	Ød1	l1	Ød1	l1	
134	55	110	40	100	-	-	-	-	-	-	-	-	1170
144	-	-	-	-	-	-	-	-	55	110	40	100	1240
154	70	135	50	110	-	-	-	-	-	-	-	-	1402
164	-	-	-	-	70	135	50	110	-	-	-	-	1448
174	70	135	50	110	-	-	-	-	-	-	-	-	1450
184	-	-	-	-	70	135	50	110	-	-	-	-	1510
194...224	Talep edildiğinde / On request / Auf Anfrage												

Gövde Size Größe	Redüktörler / Gear Units / Zahnradgetriebe													Motor Pompası Motor pump / Motorpumpe			
	a	b	c	E	f2	h	h2	m1	m2	n1	n2	p2	Øs	A#)	B#)	C#)	D#)
134	1399	901	63	820	35	272.5	300	1300	680	52	360	502	48	Talep edildiğinde On request Auf Anfrage			
144	1539	901	63	890	35	272.5	300	1440	680	52	430	502	48				
154	1684	981	74	987	42	310	340	1565	750	62	430	572	55				
164	1774	981	74	1033	42	310	340	1655	750	62	475	572	55				
174	1774	1111	83	1035	42	340	374	1640	850	72	465	632	55				
184	1894	1111	83	1095	42	340	374	1760	850	72	525	632	55				
194 ... 224	Talep edildiğinde / On request / Auf Anfrage																

#) Max ölçülerdir. Ayrıntılara siparişte gönderilen dökümanlardan ulaşılabilir.
Ölçüler mm'dir.

1) Şaftlar:

m6≤Ø100; n6>Ø100
Kama kanalı DIN 6885/1,
Kama kanalı genişliği ISO JS9 a göre
Kama DIN 6885/1 form B
Ayrıntılar için sayfa 127-136'ya bakılabilir.

4) Pompa borusu ve koruyucusunun gerçek ölçülerinin boşluğu için lütfen PGR'ye danışınız.

5) Şaft montajlı redüktörler için A, D ve G montajı istek üzerine yapılmaktadır.

*) Yaklaşık değerlerdir. Kesin verilere siparişte gönderilen dökümanlardan ulaşılabilir.

***) Redüktörler yağsızdır.

#) Max.dimensions; details acc. to order-related documentation.
Dimensions in mm

1) Shafts:

m6≤Ø100; n6>Ø100
Keyway acc.to DIN 6885/1,
Hub keyway width acc.to ISO JS9
Parallel key acc.to DIN 6885/1 form B
For details, see pages 127-136

4) Space for pump pipes and cover; for exact dimensions, please refer to us.

5) For shaft-mounted gear units, designs A, and D on request.

*) Approximate values; exact data acc. to order related documentation.

***) Without oil filling

#) Max. Abmessungen; Einzelheiten nach auftragsbezogener Dokumentation.
Abmessungen in mm

1) Wellen:

m6≤Ø100; n6>Ø100
Passfedernut nach DIN 6885/1
Nabennutbreite nach ISO JS9
Passfeder nach DIN 6885/1 Form B
Einzelheiten siehe Seiten 127-136

4) Freiraum für Pumpe, Rohr und Deckel genaue Maße ggf. anfragen.

5) Ausführungen A und D bei Aufsteckausführungen auf Anfrage.

*) Richtwerte; genaue Angaben nach auftragsbezogener Dokumentation.

***) ohne Ölfüllung

TR DÖRT KADEMELİ - DİKEY

EN FOUR STAGE - VERTICAL

DE VIERSTUFIG - VERTIKAL

	<p>PB134-SV ... PB224-SV Mil Çıkışlı Solid shaft Vollwelle</p>		Ød2	l2	G2
		134	200	350	335
		144	210	350	335
		154	230	410	380
		164	240	410	380
		174	250	410	415
		184	270	470	415
		194 204 214 224	Talep edildiğinde On request Auf Anfrage		

	<p>PB134-HV ... PB224-HV Delik millî Hollow shaft Hohlwelle</p>		ØD2	G4
		134	190	335
		144	210	335
		154	230	380
		164	240	380
		174	250	415
		184	275	415
		194 204 214 224	Talep edildiğinde On request Auf Anfrage	

	<p>5) PB134-DV ... PB224-DV Konik Sıktırmalı Hollow shaft for shrink disk Hohlwelle für schrumpfscheibe</p>		ØD2	ØD3	G4	G5
		134	190	195	335	480
		144	210	215	335	480
		154	230	235	380	550
		164	240	245	380	550
		174	250	260	415	600
		184	280	285	415	600
		194 204 214 224	Talep edildiğinde On request Auf Anfrage			

	<p>PB134-KV ... PB224-KV Spline DIN 5480 Hollow shaft with involute splines acc. to DIN 5480 Hohlwelle mit Zahnradprofil nach DIN 5480</p>		N / DIN 5480		ØD2	ØD3	G4
		134	N 190x5x30x36x9H	180	195	335	
		144	N 190x5x30x36x9H	180	215	335	
		154	N 220x5x30x42x9H	210	235	380	
		164	N 220x5x30x42x9H	210	245	380	
		174	N 250x5x30x48x9H	240	260	415	
		184	N 250x5x30x48x9H	240	285	415	
		194 204 214 224	Talep edildiğinde On request Auf Anfrage				

	<p>PB134-FV ... PB224-FV Flanşlı şaft Flanged shaft Flanschelle</p>		c	Ød2	ØD3	Øk2	nxØs	t	G7
		134	48	580	310	500	20 x 33	14	480
		144	48	620	310	540	24 x 33	14	480
		154	55	710	360	630	28 x 33	17	550
		164	55	740	360	660	30 x 33	17	550
		174	60	750	410	660	24 x 39	18	600
		184	60	800	410	710	26 x 39	18	600
		194 204 214 224	Talep edildiğinde On request Auf Anfrage						

Gövde Size Größe	Yağ miktarı Oil quantity Ölmenge (l)*	Ağırlık Weight / Gewicht (kg) ***)	
		SV HV DV KV	FV
134	135	2300	2460
144	150	2625	2795
154	210	3465	3705
164	220	3795	4050
174	270	4500	4800
184	285	4970	5320
194 - 224	Talep edildiğinde On request / Auf Anfrage		

KONİK - HELİSEL DİŞLİLİ REDÜKTÖRLER / BEVEL - HELICAL GEAR UNITS / KEGELSTIRNRADGETRIEBE

İki kademe, Dikey / Double stage, Vertical / Zweistufig, Vertikal - PB42-V ... 122-V						(1-A)
İki kademe, Dikey / Double stage, Vertical / Zweistufig, Vertikal - PB132-V ... 182-V						(1-A)
Üç kademe, Dikey / Three stage, Vertical / Dreistufig, Vertikal - PB43-V ... 123-V						(1-B)
Üç kademe, Dikey / Three stage, Vertical / Dreistufig, Vertikal - PB133-V ... 223-V						(1-B)
Dört kademe, Yatay / Four stage, Vertical / Vierstufig, Vertikal - PB54-V ... 124-V						
Dört kademe, Yatay / Four stage, Vertical / Vierstufig, Vertikal - PB134-V ... 224-V						

1) Soğutma serpantini

- A) C, D ve F dizaynları için basınçlı yağlama ile flanşlı pompa birlikte uygulanamaz.
 B) A, B ve E dizaynları için basınçlı yağlama ile flanşlı pompa birlikte uygulanamaz.
 • Motor pompası ile basınçlı yağlama istek üzerine yapılmaktadır.

1) Cooling coil:

- A) For C, D and F designs, forced lubrication by flanged-on pump not possible.
 B) For A, B and E designs, forced lubrication by flanged-on pump not possible.
 • Combination with forced lubrication by motor pump on request

1) Kühlschlange:

- A) Ausführungen C, D und F mit Druckschmierung durch Flanscpumpe nicht möglich.
 B) Ausführungen A, B und E mit Druckschmierung durch Flanscpumpe nicht möglich.
 • Kombination mit Druckschmierung durch motorpumpe auf anfrage

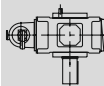

Motorlu pompa
 Motor pump
 Motorpumpe

PB42-V ... PB182-V
 PB43-V ... PB223-V
 PB54-V ... PB224-V



Yağ tankı
 Oil compensating tank
 Ölausgleichsbehälter

PB42-V ... PB122-V
 PB43-V ... PB123-V
 PB54-V ... PB124-V



Flanşlı pompa
 Flanged-on pump
 Flanscpumpe

PB42-V ... PB182-V
 PB43-V ... PB223-V
 PB54-V ... PB124-V

TR MİL UCU MERKEZİ DELİKLERİ FORMU
DS DIN332/2

EN CENTER HOLES, FORM DS IN SHAFT
ENDS DIN 332/2

DE ZENTRIERBOHRUNGEN FORM DS IN
WELLENENDEN DIN 332/2

DS Formu
Klavuz deliği ile
düz yüzeydeki düzeltme

X Detayı
Detail "X"
Einzelheit "X"

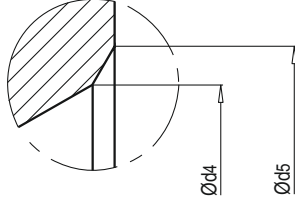

Forms DS
Tapped hole, with straight running
face and counterbore

Kama kanalı
Keyway
Passfedernut

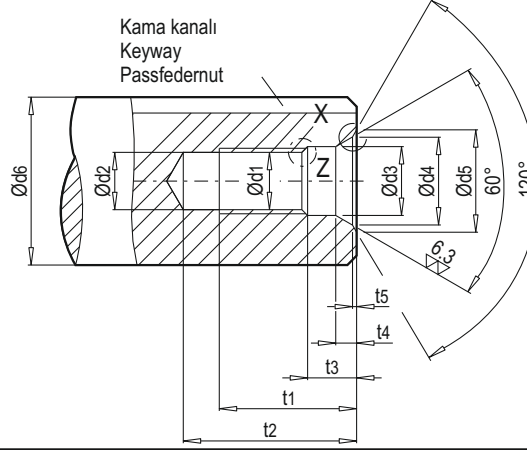

Forms DS
mit Gewinde, gerader Lauffläche
und Schutzsenkung

Z Detayı
Detail "Z"
Einzelheit "Z"

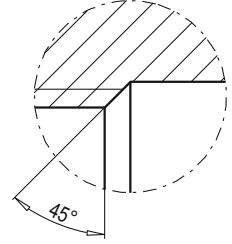

Önerilen çaplar Recommended diameters Empfohlene Durchmesserbereiche Ød6 1)		DS Formu / Form DS / Form DS														
Üstünde above über	kadar to bis	DS- Merkez Centering Zentrierung	Ød1	Ød2 2)	Ød3	Ød4	Ød5	t1		t2		t3	t4	t5		
								+2	min.	max.	+1				≈	≈
mm	mm							mm								
16	21	DS 6	M 6	5.0	6.4	9.6	10.5	16.0	21	23	5.0	2.8	0.4			
21	24	DS 8	M 8	6.8	8.4	12.2	13.2	19.0	25	28	6.0	3.3	0.4			
24	30	DS 10	M 10	8.5	10.5	14.9	16.3	22.0	30	34	7.5	3.8	0.6			
30	38	DS 12	M 12	10.2	13.0	18.1	19.8	28.0	37	42	9.5	4.4	0.7			
38	50	DS 16	M 16	14.0	17.0	23.0	25.3	36.0	45	50	12.0	5.2	1.0			
50	85	DS 20	M 20	17.5	21.0	28.4	31.3	42.0	53	59	15.0	6.4	1.3			
85	130	DS 24	M 24	21.0	25.0	34.2	38.0	50.0	63	68	18.0	8.0	1.6			
130	225	DS 30 *	M 30	26.5	31.0	40.2	44.6	60.0	77	83	17.0	8.0	1.9			
225	320	DS 36 *	M 36	32.0	37.0	49.7	55.0	74.0	93	99	22.0	11.0	2.3			
320	500	DS 42 *	M 42	37.5	43.0	60.3	66.6	84.0	105	111	26.0	15.0	2.7			

- 1) Bitmiş iş parçası çapı
2) DIN 336-1 e göre klavuzların matkap çapları
* Ölçü, DIN 332'e göre değildir.

- 1) Diameter of the finished work piece
2) Drill diameters for tapping- size holes acc.to DIN 336 Pt.1
* Dimensions not acc. to DIN 332

- 1) Durchmesser gilt für das fertige Werkstück
2) Kernloch-bohrerdurchmesser nach DIN 336 Teil1
* Abmessungen nicht nach DIN 332

Koruma / Muhafaza

Guards

Schutzhauben

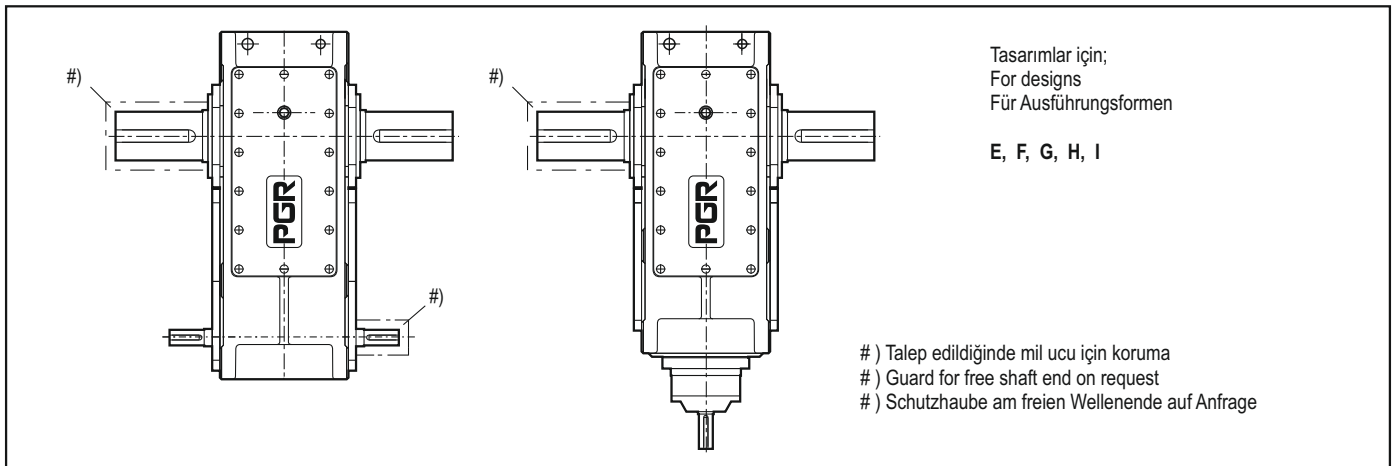

Tasarımlar için;
For designs
Für Ausführungsformen

E, F, G, H, I

- #) Talep edildiğinde mil ucu için koruma
#) Guard for free shaft end on request
#) Schutzhaube am freien Wellenende auf Anfrage

Uygunluk Belirlemede Dikkate Alınması Gereken Özellikleri / Selection of ISO fits / Passungsauswahl				
Uygun ISO seçimi Selection of ISO fits Passungsauswahl	Şaft / Shaft / Welle Ød		Mil toleransı Shaft tolerance Wellentoleranz	Çap toleransı Bore tolerance Bohrungstoleranz
	üstünde above über mm	kadar to bis mm		
PGR standartlarına göre mil toleransı Shaft tolerance acc. to PGR Standard Wellentoleranz nach PGR Norm		25	k6	H7
	25	100	m6	
	100		n6	

Ağır çalışma koşulları, örneğin; Yük altında geri çevrilmesi, burada sıkı bir uyum tavsiye edilir ve göbek kama genişliği için ISO P9 tolerans seçilir

For heavy-duty operating conditions, e.g. reversing under load, it is recommended that a tighter fit and for the hub keyway width the ISO P9 tolerance is selected.

Für außergewöhnliche Betriebsverhältnisse, z.B. Reversierbetrieb unter Last, ist ein festerer Sitz und für die Nabennutbreite das ISO- Toleranzfeld P9 vorzusehen.

Bu durumda, müşteri ilgili bilgileri vermelidir.

In this case, the customer should give the relevant information.

Seitens des Kunden sind hierzu entsprechende Vorgaben notwendig.

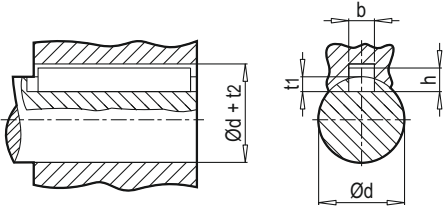
Paralel kamalar / Parallel keys / Passfedern						
Bağlantı, incelmeyen tipte tahrik civatalarıyla yapılır. Drive type fastening without taper action Mitnehmerverbindung ohne Anzug	Çap Diameter Durchmesser Ød		Genişlik Width Breite b 1)	Yükseklik Height Höhe h	Şafttaki kama kanalı derinliği Depth of key- way in shaft Wellennuttiefe t ₁	Delikten kama kanalı derinliği Depth of key- way in hub Nabennuttiefe Ød + t ₂ DIN 6885/1 mm
	Üstünde above über mm	kadar to bis mm				
	mm	mm				
Kama ve kama kanalı DIN 6885/1 'e göre	17	22	6	6	3.5	d + 2.8
	22	30	8	7	4	d + 3.3
Paralel key and keyway acc. to DIN 6885/1	30	38	10	8	5	d + 3.3
	38	44	12	8	5	d + 3.3
Passfeder und Nut nach DIN 6885/1	44	50	14	9	5.5	d + 3.8
	50	58	16	10	6	d + 4.3
	58	65	18	11	7	d + 4.4
	65	75	20	12	7.5	d + 4.9
	75	85	22	14	9	d + 5.4
1) Kamalar için, göbek kaması yuva genişliği (b) tolerans aralığı ISO JS9'dur ve çalışma şartlarının ağır olması durumunda ise, ISO P9'dur. 1) The tolerance zone for the hub keyway width b for parallel keys is ISO JS9 , or ISO P9 for heavy-duty operating conditions. 1) Das Toleranzfeld der Nabennutbreite b für Passfedern ist ISO JS9, bzw. ISO P9 bei erschwerten Betriebsbedingungen.	85	95	25	14	9	d + 5.4
	95	110	28	16	10	d + 6.4
	110	130	32	18	11	d + 7.4
	130	150	36	20	12	d + 8.4
	150	170	40	22	13	d + 9.4
	170	200	45	25	15	d + 10.4
	200	230	50	28	17	d + 11.4
	230	260	56	32	20	d + 12.4
	260	290	63	32	20	d + 12.4
	290	330	70	36	22	d + 14.4
	330	380	80	40	25	d + 15.4
	380	440	90	45	28	d + 17.4

TR KONİK SIKTIRMALI ŞAFTLAR

EN HOLLOW SHAFTS FOR SHRINK DISKS

DE HOHLWELLEN FÜR SCHRUMPFSCHEIBEN

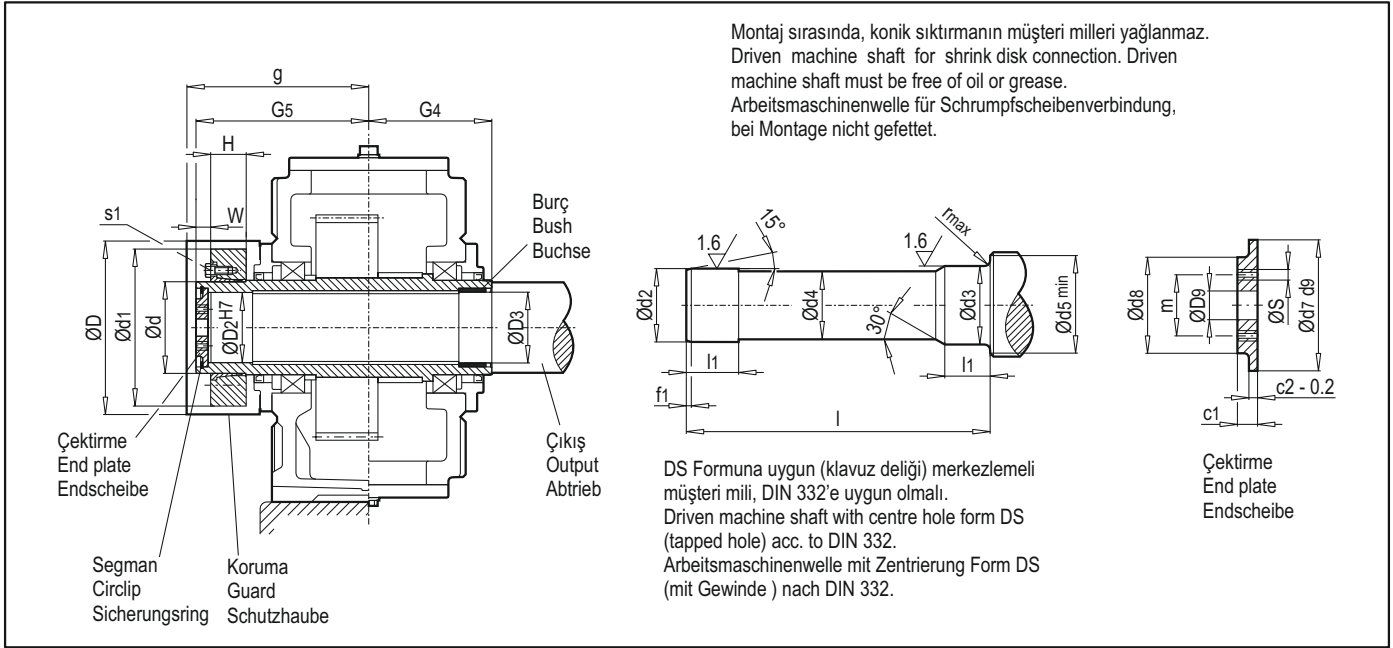

Tipler / Types / Bauarten PH...2-D, PH...3-D, PH...4-D, PB...3-D, PB...4-D

Redüktör gövdeleri Gear unit size Getriebe- größe	Sürücü makinesi mili Driven machine shaft Arbeitsmaschinenwelle 2)														Segman Circlip Sicher- ungsring	Delik Mili shaft Hollow shaft Hohlwelle				Konik sıkırtma Shrink disk Schrumpfscheibe				Civata Screw Schra- be	Koruma Guard Schutz- haube			
	Ød2	Ød3	Ød4	Ød5	f1	l	l1	r	c1	c2	Ød7	Ød8	Ød9	m		Øs	Adt. Qty An- zahl	DIN 472	ØD2	ØD3	G4	G5	Ød			Ød1	H	W
mm														mm														
PH/PB4...	85 g6	85 h6	84.5	95	4	326	48	2	17	7	90	70	22	50	M8	2	90 x 3	85	85	140	205	110	185	51	20	M 12	237	226
PH/PB5...	100 g6	100 h6	99.5	114	5	383	53	2	20	8	105	80	26	55	M10	2	105 x 4	100	100	165	240	125	215	55	20	M 12	277	261
PH/PB6...	110 g6	110 h6	109.5	124	5	383	58	3	20	8	115	85	26	60	M10	2	115 x 4	110	110	165	240	140	230	61	20	M 14	287	256
PH/PB7...	120 g6	120 h6	119.5	134	5	453	68	3	20	8	125	90	26	65	M12	2	125 x 4	120	120	195	280	155	265	64	23	M 14	332	306
PH/PB8...	130 g6	130 h6	129.5	145	6	458	73	3	20	8	135	100	26	70	M12	2	135 x 4	130	130	195	285	165	290	70	23	M 16	342	306
PH/PB9...	140 g6	145 m6	139.5	160	6	539	82	4	23	10	150	110	33	80	M12	2	150 x 4	140	145	235	330	175	300	71	28	M 16	362	356
PH/PB10...	150 g6	155 m6	149.5	170	6	559	92	4	23	10	160	120	33	90	M12	2	160 x 4	150	155	235	350	185	330	87	28	M 16	397	366
PH/PB11...	165 f6	170 m6	164.5	185	7	644	112	4	23	10	175	130	33	90	M12	2	175 x 4	165	170	270	400	220	370	103	30	M 20	437	421
PH/PB12...	180 f6	185 m6	179.5	200	7	649	122	4	23	10	190	140	33	100	M16	2	190 x 4	180	185	270	405	240	405	107	30	M 20	452	421
PH/PB13...	190 f6	195 m6	189.5	213	7	789	137	5	23	10	200	150	33	110	M16	2	200 x 4	190	195	335	480	260	430	119	30	M 20	502	506
PH/PB14...	210 f6	215 m6	209.5	233	8	784	147	5	28	14	220	170	33	130	M16	2	220 x 5	210	215	335	480	280	460	132	30	M 20	527	506
PH/PB15...	230 f6	235 m6	229.5	253	8	899	157	5	28	14	240	180	39	140	M16	2	240 x 5	230	235	380	550	300	485	140	35	M 24	577	576
PH/PB16...	240 f6	245 m6	239.5	263	8	899	157	5	28	14	250	190	39	150	M20	2	250 x 5	240	245	380	550	320	520	140	35	M 24	597	576
PH/PB17...	250 f6	260 m6	249.5	278	8	982	177	5	30	14	265	200	39	150	M20	2	265 x 5	250	260	415	600	340	570	155	35	M 24	617	631
PH/PB18...	280 f6	285 m6	279.5	306	9	982	177	5	30	14	290	210	39	160	M20	2	290 x 5	280	285	415	600	360	590	162	35	M 24	637	626
PH/PB19...	285 f6	295 m6	284.5	316	9	1100	187	5	32	15	300	220	39	170	M24	2	300 x 5	285	295	465	670	380	640	166	40	M 27	-	-
PH/PB20...	310 f6	315 m6	309.5	336	9	1100	187	5	32	15	320	230	39	180	M24	2	320 x 6	310	315	465	670	390	650	166	40	M 27	-	-
PH/PB21...	330 f6	335 m6	329	358	9	1160	205	5	40	20	340	250	45	190	M24	2	340 x 6	330	335	490	715	420	670	186	45	M 27	-	-
PH/PB22...	340 f6	345 m6	339	368	9	1170	215	5	40	20	350	260	45	200	M24	2	350 x 6	340	345	490	725	440	720	194	45	M 27	-	-

- 1) Konik sıkırtma, teslimat kapsamına dahil değildir. İhtiyaç olması durumunda, ayrıca sipariş edilmelidir. Konik sıkırtmanın sipariş edilmesi durumunda, siparişle birlikte ayrı olarak teslim edilir.
- 2) Müşteri milinin malzeme mukavemet değeri, C60N veya üstü olmalıdır. Konik sıkırtma talep edildiğinde, makineyle birlikte teslim edilir.

- 1) Shrink disk does not belong to our scope of supply. Please order separately, if required. In case of order, shrink disk will be supplied as loose item.
- 2) Material of driven machine shaft: C60N or higher strength. Shrink disk on machine side on request.

- 1) Schrumpfscheibe gehört nicht zum Lieferumfang. Bei Bedarf gesondert bestellen. Schrumpfscheibe wird bei Bestellung lose mitgeliefert.
- 2) Werkstoff Arbeitsmaschinenwelle C60N oder höhere Festigkeit. Schrumpfscheibe an Maschinenseite auf Anfrage.

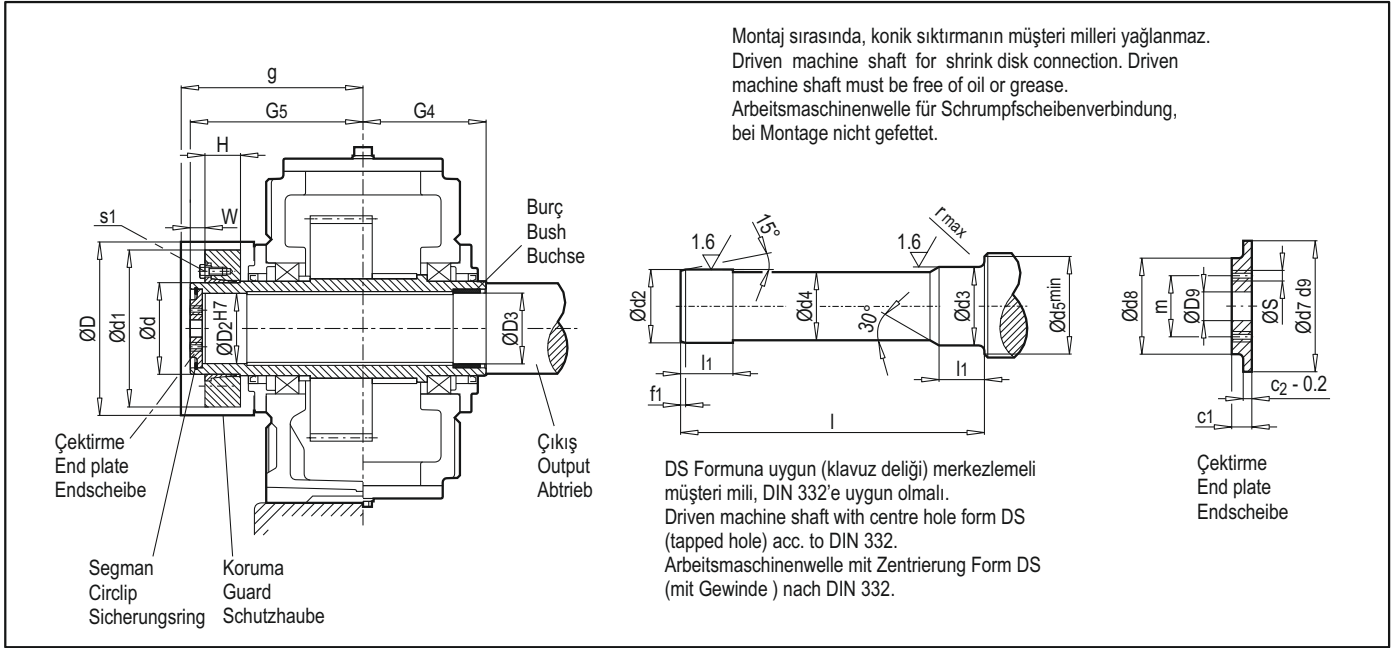

Tip / Type / Bauart B...2-D																														
Redüktör gövdesi Gear unit size Getriebe- größe	Müşteri makinesi mili Driven machine shaft Arbeitsmaschinenwelle														Çıktırma End plate Endscheibe				Segman Circlip Sicherungsring	Delik Mil Hollow shaft Hohlwelle				Konik sıkırtma Shrink disk Schrumpfscheibe				Cıvata Screw Schraube	Koruma Guard Schutz- haube	
	Ød2	Ød3	Ød4	Ød5	f1	l	l1	r	c1	c2	Ød7	Ød8	ØD9	m	Øs	DIN 472	ØD2	ØD3		G4	G5	Ød	Ød1	H	W	Øs1	ØD		g	
	mm														mm															
42	85 g6	85 h6	84.5	95	4	386	48	2	17	7	90	70	22	50	M8	2	90 x 3	85	85	170	235	110	185	51	20	M12	237	256		
52	100 g6	100 h6	99.5	114	5	453	53	2	20	8	105	80	26	55	M10	2	105 x 4	100	100	200	275	125	215	55	20	M12	277	291		
62	110 g6	110 h6	109.5	124	5	453	58	3	20	8	115	85	26	60	M10	2	115 x 4	110	110	200	275	140	230	61	20	M14	287	286		
72	120 g6	120 h6	119.5	134	5	533	68	3	20	8	125	90	26	65	M12	2	125 x 4	120	120	235	320	155	265	64	23	M14	332	346		
82	130 g6	130 h6	129.5	145	6	538	73	3	20	8	135	100	26	70	M12	2	135 x 4	130	130	235	325	165	290	70	23	M16	342	346		
92	140 g6	145 m6	139.5	160	6	609	82	4	23	10	150	110	33	80	M12	2	150 x 4	140	145	270	365	175	300	71	28	M16	362	391		
102	150 g6	155 m6	149.5	170	6	629	92	4	23	10	160	120	33	90	M12	2	160 x 4	150	155	270	385	185	330	87	28	M16	397	401		
112	165 f6	170 m6	164.5	185	7	744	112	4	23	10	175	130	33	90	M12	2	175 x 4	165	170	320	450	220	370	103	30	M20	437	471		
122	180 f6	185 m6	179.5	200	7	749	122	4	23	10	190	140	33	100	M16	2	190 x 4	180	185	320	455	240	405	107	30	M20	452	471		
142	210 f6	215 m6	209.5	233	8	894	147	5	28	14	220	170	33	130	M16	2	220 x 5	210	215	390	535	280	460	132	30	M20	527	556		
162	240 f6	245 m6	239.5	263	8	1039	157	5	28	14	250	190	39	150	M20	2	250 x 5	240	245	450	620	320	520	140	35	M24	597	646		
182	280 f6	285 m6	279.5	306	9	1177	177	5	30	14	290	210	39	160	M20	2	290 x 5	280	285	510	700	360	590	162	35	M24	637	726		

- 1) Konik sıkırtma, teslimat kapsamına dahil değildir. İhtiyaç olması durumunda, ayrıca sipariş edilmelidir. Konik sıkırtmanın sipariş edilmesi durumunda, siparişe birlikte ayrı olarak teslim edilir.
- 2) İş makinesi milinin malzeme mukavemet değeri, C60N veya üstü olmalıdır. Konik sıkırtma talep edildiğinde, makineyle birlikte teslim edilir.

- 1) Shrink disk does not belong to our scope of supply. Please order separately, if required. In case of order, shrink disk will be supplied as loose item.
- 2) Material of driven machine shaft: C60N or higher strength. Shrink disk on machine side on request.

- 1) Schrumpfscheibe gehört nicht zum Lieferumfang. Bei Bedarf gesondert bestellen. Schrumpfscheibe wird bei Bestellung lose mitgeliefert.
- 2) Werkstoff Arbeitsmaschinenwelle C60N oder höhere Festigkeit. Schrumpfscheibe an Maschinenseite auf Anfrage.

TR KAMA KANALLI ŞAFTLAR

EN HOLLOW SHAFTS FOR PARALLEL KEY CONNECTIONS

DE HOHLWELLEN FÜR PASSFEDER VERBINDUNGEN

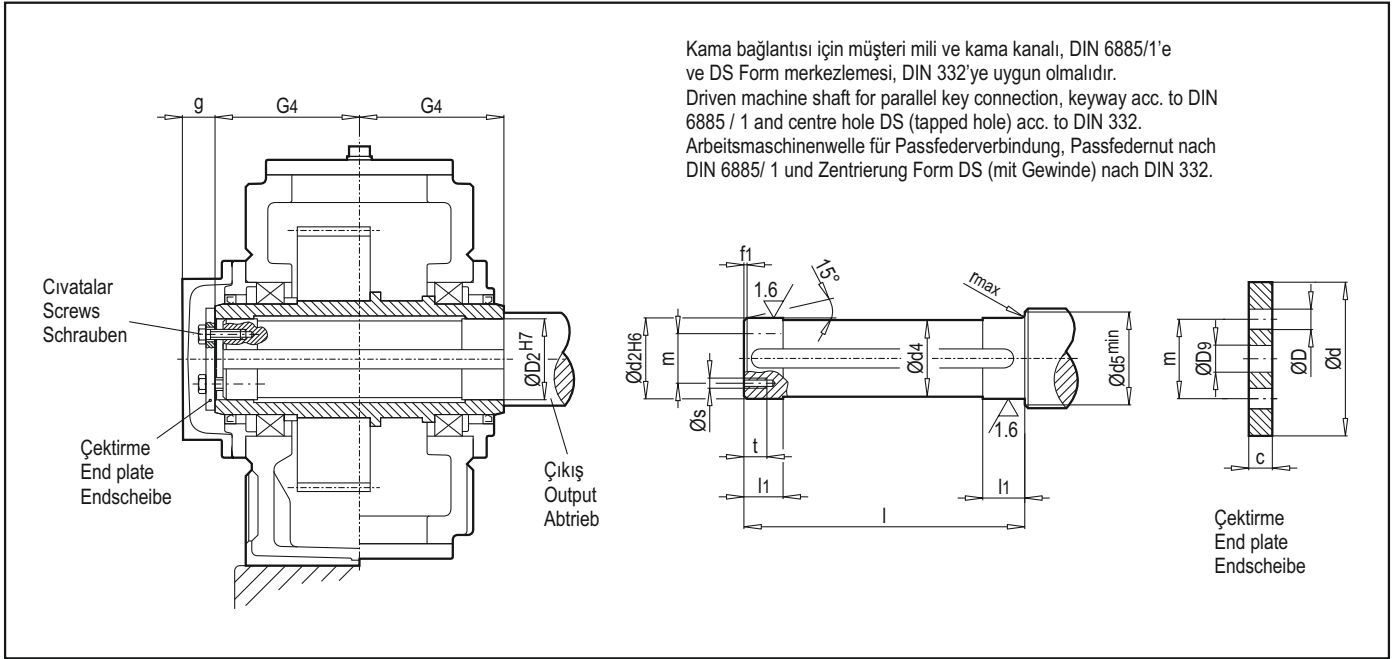

Tipler / Types / Bauarten PH...2-H, PH...3-H, PH...4-H, PB...3-H, PB...4-H.																			
Redüktör gövdeleri Gear unit size Getriebe- größe	Müşteri makinesi mili Driven machine shaft Arbeitsmaschinenwelle									Çektirme End plate Endscheibe				Cıvata Screw Schraube		Delik milli shaft Hollow shaft Hohlwelle			
	Ød2	Ød4	Ød5	f1	l	l1	r	Øs	t	c	ØD	ØD9	Ød	m	Boyut Size Größe	Adet Qty. Anzahl	ØD2	G4	g
mm																			
PH/PB4...	80	79.5	88	4	278	35	1.2	M10	18	10	11	22	100	60	M10 x 25	2	80	140	36
PH/PB5...	95	94.5	105	5	328	40	1.6	M10	18	10	11	26	120	70	M10 x 25	2	95	165	41
PH/PB6...	105	104.5	116	5	328	45	1.6	M10	18	10	11	26	120	70	M10 x 25	2	105	165	41
PH/PB7...	115	114.5	126	5	388	50	1.6	M12	20	12	13.5	26	140	80	M12 x 30	2	115	195	41
PH/PB8...	125	124.5	136	6	388	55	2.5	M12	20	12	13.5	26	150	85	M12 x 30	2	125	195	41
PH/PB9...	135	134.5	147	6	467	60	2.5	M12	20	12	13.5	33	160	90	M12 x 30	2	135	235	46
PH/PB10...	150	149.5	162	6	467	65	2.5	M12	20	12	13.5	33	185	110	M12 x 30	2	150	235	46
PH/PB11...	165	164.5	177	7	537	70	2.5	M16	28	15	17.5	33	195	120	M16 x 40	2	165	270	46
PH/PB12...	180	179.5	192	7	537	75	2.5	M16	28	15	17.5	33	220	130	M16 x 40	2	180	270	46
PH/PB13...	190	189.5	206	7	667	80	3	M16	28	18	17.5	33	230	140	M16 x 40	2	190	335	46
PH/PB14...	210	209.5	226	8	667	85	3	M16	28	18	17.5	33	250	160	M16 x 40	2	210	335	46
PH/PB15...	230	229.5	248	8	756	100	3	M20	38	25	22	39	270	180	M20 x 55	4	230	380	61
PH/PB16...	240	239.5	258	8	756	100	3	M20	38	25	22	39	280	180	M20 x 55	4	240	380	61
PH/PB17...	250	249.5	270	8	826	110	4	M20	38	25	22	39	300	190	M20 x 55	4	250	415	61
PH/PB18...	275	274.5	295	9	826	120	4	M20	38	25	22	39	330	210	M20 x 55	4	275	415	61

1) Müşteri milinin malzeme mukavemet değeri, C60N veya üstü olmalıdır.

1) Material of driven machine shaft: C60N or higher strength.

1) Werkstoff Arbeitsmaschinenwelle C60N oder höhere Festigkeit.

Kama, teslimat kapsamına dahil değildir. İhtiyaç olması durumunda, ayrıca sipariş edilmelidir.

Parallel key does not belong to our scope of supply. Please order separately, if required.

Passfeder gehört nicht zum Lieferumfang. Bei Bedarf gesondert bestellen.

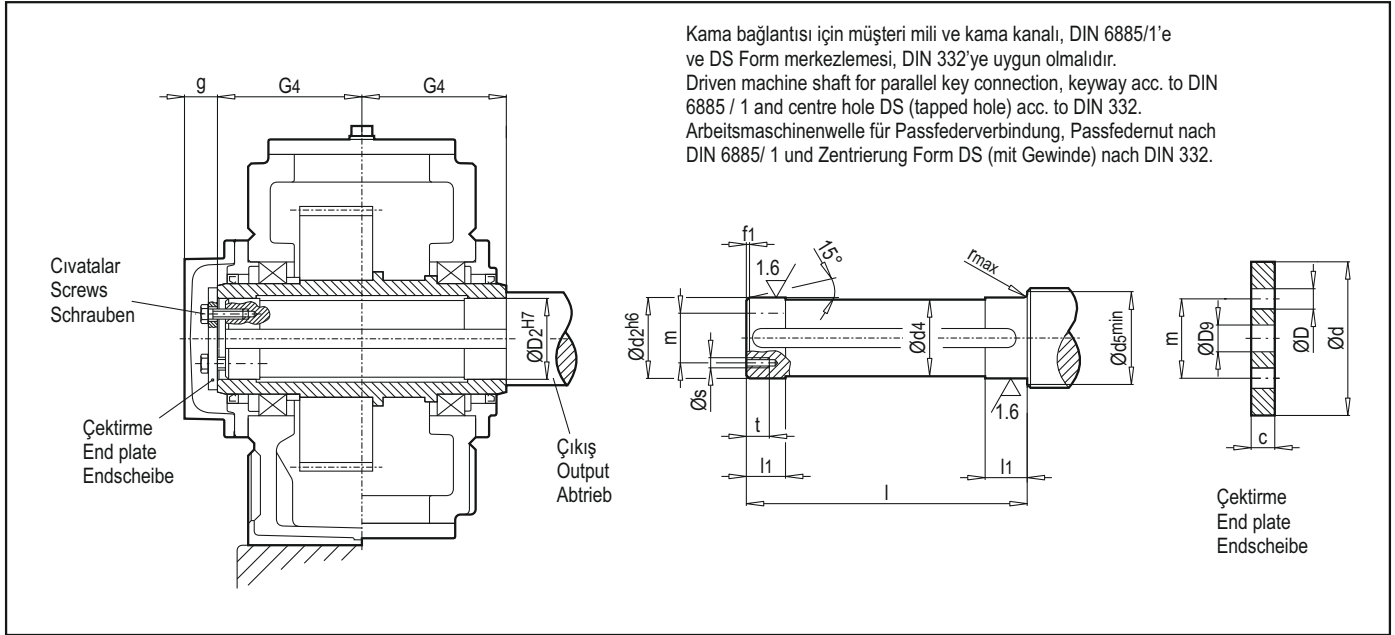
TR KAMA KANALLI ŞAFTLAR
EN HOLLOW SHAFTS FOR PARALLEL KEY CONNECTIONS
DE HOHLWELLEN FÜR PASSFEDERVERBINDUNGEN

Tip / Type / Bauart PB...2-H

Redüktör Gövdeleri Gear unit size Getriebe-größe	Müşteri makine mili 1) Driven machine shaft Arbeitsmaschinenwelle									Çektirme End plate Endscheibe				Civata Screw Schraube		Delik milli şaft Hollow shaft Hohlwelle			
	Ød2	Ød4	Ød5	f1	l	l1	r	Øs	t	c	ØD	ØD9	Ød	m	Boyut Size Größe	Adet Qty Anzahl	ØD2	G4	g
	mm																		
42	80	79.5	88	4	338	35	1.2	M10	18	10	11	22	100	60	M10 x 25	2	80	170	36
52	95	94.5	105	5	398	40	1.6	M10	18	10	11	26	120	70	M10 x 25	2	95	200	41
62	105	104.5	116	5	398	45	1.6	M10	18	10	11	26	120	70	M10 x 25	2	105	200	41
72	115	114.5	126	5	468	50	1.6	M12	20	12	13.5	26	140	80	M12 x 30	2	115	235	41
82	125	124.5	136	6	468	55	2.5	M12	20	12	13.5	26	150	85	M12 x 30	2	125	235	41
92	135	134.5	147	6	537	60	2.5	M12	20	12	13.5	33	160	90	M12 x 30	2	135	270	46
102	150	149.5	162	6	537	65	2.5	M12	20	12	13.5	33	185	110	M12 x 30	2	150	270	46
112	165	164.5	177	7	637	70	2.5	M16	28	15	17.5	33	195	120	M16 x 40	2	165	320	46
122	180	179.5	192	7	637	75	2.5	M16	28	15	17.5	33	220	130	M16 x 40	2	180	320	46
142	210	209.5	226	8	777	85	3	M16	28	18	17.5	33	250	160	M16 x 40	2	210	390	46
162	240	239.5	258	8	896	100	3	M20	38	25	22	39	280	180	M20 x 55	4	240	450	61
182	275	274.5	295	9	1016	120	4	M20	38	25	22	39	330	210	M20 x 55	4	275	510	61

1) Müşteri milinin malzeme mukavemet değeri, C60N veya üstü olmalıdır.

1) Material of driven machine shaft: C60N or higher strength.

1) Werkstoff Arbeitsmaschinenwelle C60N oder höhere Festigkeit.

Kama, teslimat kapsamına dahil değildir. İhtiyaç olması durumunda, ayrıca sipariş edilmelidir.

Parallel key does not belong to our scope of supply. Please order separately, if required.

Passfeder gehört nicht zum Lieferumfang. Bei Bedarf gesondert bestellen

TR DELİK MİLLİ SPLİNE ŞAFTLAR DIN 5480

EN HOLLOW SHAFT WITH INVOLUTE SPLINES ACC. TO DIN 5480

DE HOHLWELLEN MIT ZAHNNABENPROFIL NACH DIN 5480

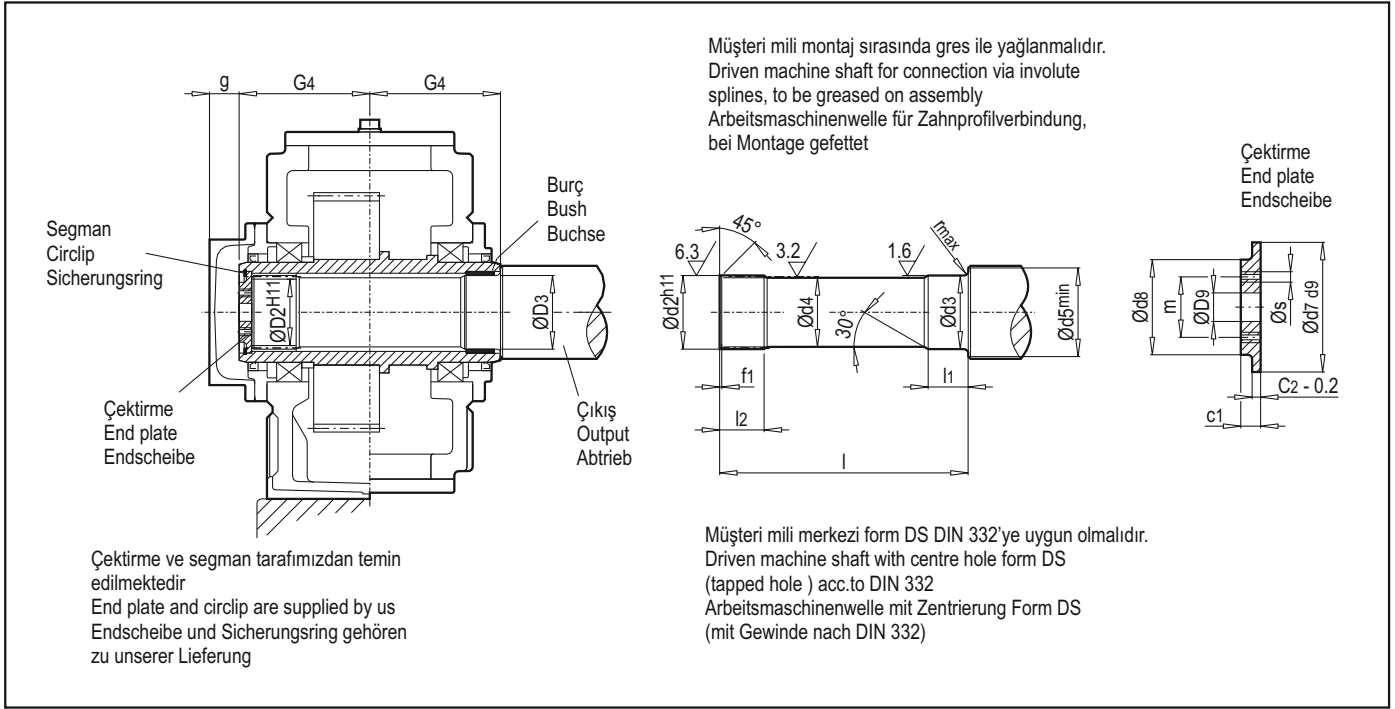

Tipler / Types / Bauarten PH...2-K, PH...3-K, PH...4-K, PB...3-K, PB...4-K																								
Redüktör Gövdeleri Gear unit size Getriebe- größe	Evolverte spline Involute splines Zahnwellenprofil DIN 5480	Müşteri makine mili 1) Driven machine shaft Arbeitsmaschinenwelle										Çektirme End plate Endscheibe						Segman Circlip Sicherungsring DIN 472	Delik milli shaft Hollow shaft Hohlwelle				Cıvata Screw Schraube	
		Ød2	Ød3	Ød4	Ød5	f1	l	l1	l2	r	c1	c2	Ød7	Ød8	Ød9	m	Øs		Adet Qty Anzahl	ØD2	ØD3	G4		g
		mm										mm												
PH/PB5...	W 95x3x30x30x8f	94.4	100 h6	93	114	3	308	53	90	2	20	8	105	80	26	55	M10	2	105 x 4	89	100	165	41	M24
PH/PB6...	W 95x3x30x30x8f	94.4	110 h6	93	124	3	308	58	90	3	20	8	105	80	26	55	M10	2	105 x 4	89	110	165	41	M24
PH/PB7...	W120x3x30x38x8f	119.4	120 h6	118	134	3	368	68	105	3	20	8	125	90	26	65	M12	2	125 x 4	114	120	195	41	M24
PH/PB8...	W120x3x30x38x8f	119.4	130 h6	118	145	3	368	73	105	3	20	8	125	90	26	65	M12	2	125 x 4	114	130	195	41	M24
PH/PB9...	W140x3x30x45x8f	139.4	145 m6	138	160	3	444	82	125	4	23	10	150	110	33	80	M12	2	150 x 4	134	145	235	46	M30
PH/PB10...	W140x3x30x45x8f	139.4	155 m6	138	170	3	444	92	125	4	23	10	150	110	33	80	M12	2	150 x 4	134	155	235	46	M30
PH/PB11...	W170x5x30x32x8f	169	170 m6	168	185	5	514	112	150	4	23	10	175	130	33	90	M12	2	175 x 4	160	170	270	46	M30
PH/PB12...	W170x5x30x32x8f	169	185 m6	168	200	5	514	122	150	4	23	10	175	130	33	90	M12	2	175 x 4	160	185	270	46	M30
PH/PB13...	W190x5x30x36x8f	189	195 m6	188	213	5	644	137	180	5	23	10	200	150	33	110	M16	2	200 x 4	180	195	335	46	M30
PH/PB14...	W190x5x30x36x8f	189	215 m6	188	233	5	644	147	180	5	23	10	200	150	33	110	M16	2	200 x 4	180	215	335	46	M30
PH/PB15...	W220x5x30x42x8f	219	235 m6	218	253	5	728	157	200	5	28	14	240	180	39	140	M16	2	240 x 5	210	235	380	61	M36
PH/PB16...	W220x5x30x42x8f	219	245 m6	218	263	5	728	157	200	5	28	14	240	180	39	140	M16	2	240 x 5	210	245	380	61	M36
PH/PB17...	W250x5x30x48x8f	249	260 m6	248	278	5	796	177	215	5	30	14	265	200	39	150	M20	2	265 x 5	240	260	415	61	M36
PH/PB18...	W250x5x30x48x8f	249	285 m6	248	306	5	796	177	215	5	30	14	265	200	39	150	M20	2	265 x 5	240	285	415	61	M36
PH/PB19... PH/PB20... PH/PB21... PH/PB22...	Talep edildiğinde / On request / Auf Anfrage																							

1) Müşteri milinin malzemesi: C60N veya daha yüksek dayanım.

1) Material of driven machine shaft: C60N or higher strength.

1) Werkstoff Arbeitsmaschinenwelle C60N oder höhere Festigkeit.

TR DELİK MİLLİ SPLİNE ŞAFTLAR DIN 5480

EN HOLLOW SHAFT WITH INVOLUTE SPLINES ACC. TO DIN 5480

DE HOHLWELLEN MIT ZAHNNABENPROFIL NACH DIN 5480

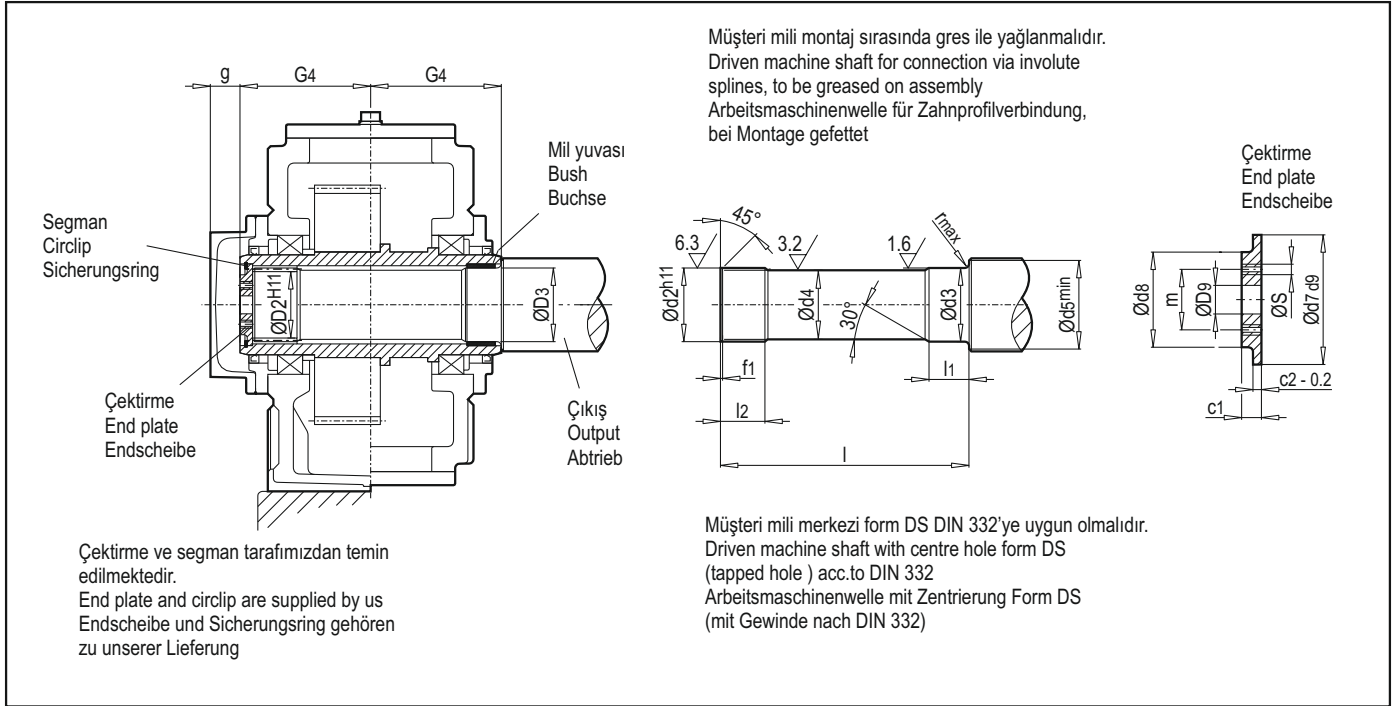

Tip / Type / Bauart PB...2-K

Redüktör Gövdesi Gear unit size Getriebe- größen	Müşteri makinesi mili Driven machine shaft Arbeitsmaschinenwelle 1)	Çektirme End plate Endscheibe										Segman Cırcılp Sicherungsring DIN 472	Delik milli shaft Hohlwelle				Cıvata Screw Schraube							
		Evolvent spline Involute splines Zahnwellenprofil DIN 5480											Adet Qty. Anzahl	ØD2	ØD3	G4		g						
		Ød2	Ød3	Ød4	Ød5	f1	l	l1	l2	r	c1								c2	Ød7	Ød8	ØD9	m	Øs
52	W95x3x30x30x8f	94.4	100 h6	93	114	3	378	53	90	2	20	8	105	80	26	55	M10	2	105 x 4	89	100	200	41	M24
62	W95x3x30x30x8f	94.4	110 h6	93	124	3	378	58	90	3	20	8	105	80	26	55	M10	2	105 x 4	89	110	200	41	M24
72	W120x3x30x38x8f	119.4	120 h6	118	134	3	448	68	105	3	20	8	125	90	26	65	M12	2	125 x 4	114	120	235	41	M24
82	W120x3x30x38x8f	119.4	130 h6	118	145	3	448	73	105	3	20	8	125	90	26	65	M12	2	125 x 4	114	130	235	41	M24
92	W140x3x30x45x8f	139.4	145 m6	138	160	3	514	82	125	4	23	10	150	110	33	80	M12	2	150 x 4	134	145	270	46	M30
102	W140x3x30x45x8f	139.4	155 m6	138	170	3	514	92	125	4	23	10	150	110	33	80	M12	2	150 x 4	134	155	270	46	M30
112	W170x5x30x32x8f	169	170 m6	168	185	5	614	112	150	4	23	10	175	130	33	90	M12	2	175 x 4	160	170	320	46	M30
122	W170x5x30x32x8f	169	185 m6	168	200	5	614	122	150	4	23	10	175	130	33	90	M12	2	175 x 4	160	185	320	46	M30
142	W190x5x30x36x8f	189	215 m6	188	233	5	754	147	180	5	23	10	200	150	33	110	M16	2	200 x 4	180	215	390	46	M30
162	W220x5x30x42x8f	219	245 m6	218	263	5	868	157	200	5	28	14	240	180	39	140	M16	2	240 x 5	210	245	450	61	M36
182	W250x5x30x48x8f	249	285 m6	248	306	5	986	177	215	5	30	14	265	200	39	150	M20	2	265 x 5	240	285	510	61	M36

1) Müşteri milinin malzemesi : C60N veya daha yüksek dayanım.

1) Material of driven machine shaft: C60N or higher strength.

1) Werkstoff Arbeitsmaschinenwelle C60N oder höhere Festigkeit.

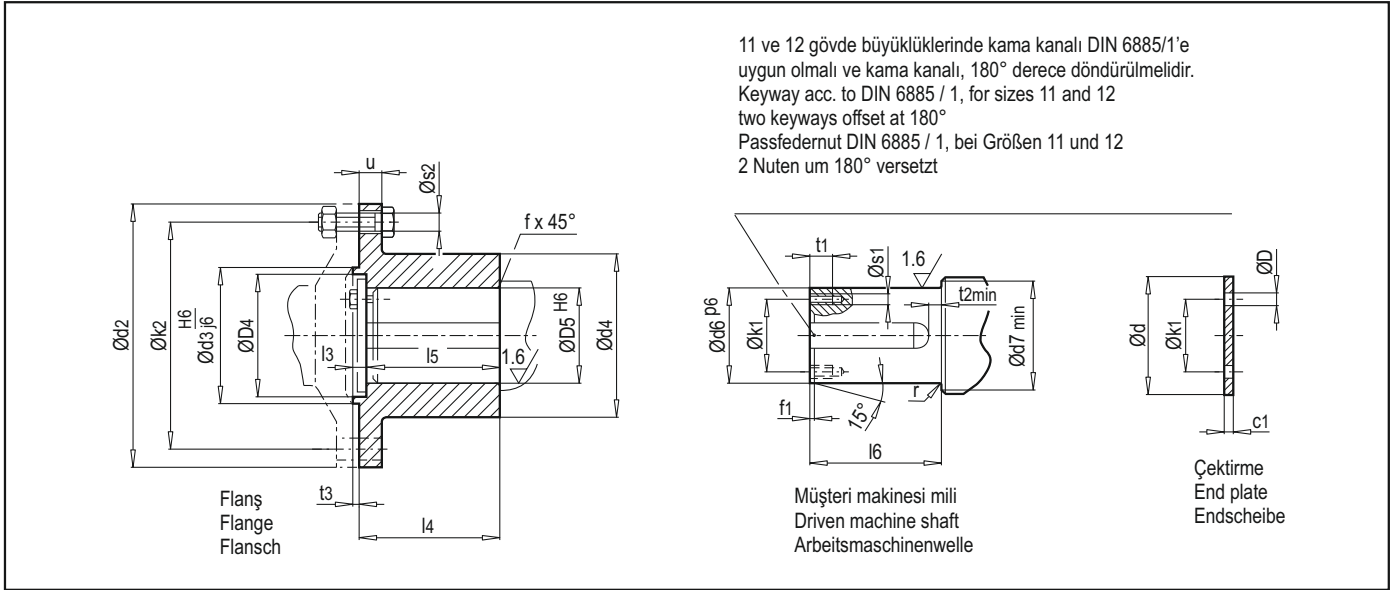

Tipler / Types / Bauarten PH...2-F, PH...3-F, PH...4-F, PB...2-F, PB...3-F, PB...4-F

Redüktör Gövdesi Gear unit size Getriebe- größe	Flanş / Flange / Flansch												Cıvata 1) Bolt Schraube			
	Ød2	Ød3	Ød4	ØD4	ØD5	f	k2	l3	l4	l5	Øs2	t3	u	Boyut Size Größe	Adet Qty Anzahl	TA 2) Nm
	mm															
PH/PB5...	300	150	191	135	110	2.5	260	16	175	167	M20	8	26	M20x70	16	610
PH/PB6...	320	160	211	145	120	2.5	280	22	185	171	M20	8	26	M20x70	18	610
PH/PB7...	370	180	231	160	135	2.5	320	21	220	207	M24	8	31	M24x90	16	1050
PH/PB8...	390	190	271	175	150	2.5	340	22	220	206	M24	8	31	M24x90	18	1050
PH/PB9...	430	220	291	195	160	4.0	380	22	250	238	M24	10	39	M24x100	20	1050
PH/PB10...	470	240	311	220	180	4.0	420	22	250	238	M24	10	39	M24x100	22	1050
PH/PB11...	510	260	341	235	200	4.0	450	22	290	278	M30	10	43	M30x120	18	2100
PH/PB12...	540	280	361	255	210	4.0	480	22	290	278	M30	10	43	M30x120	22	2100

Redüktör Gövdesi Gear unit size Getriebe- größe	Müşteri makinesi mili Driven machine shaft Arbeitsmaschinenwelle									Çektirme End plate Endscheibe				Cıvata Bolt Schraube		Ağırlık Weight Gewicht
	Ød6	Ød7	f1	k1	l6	r	Øs1	t1	t2	c1	Ød	ØD	k1	Boyut Size Größe	Adet Qty Anzahl	
	mm									mm						
PH/PB5...	110	122	2.5	80	165	2	M12	28	7.5	10	130	13.5	80	M12x35	4	35
PH/PB6...	120	132	2.5	95	169	2	M16	32	7.5	14	140	17.5	95	M16x45	4	45
PH/PB7...	135	147	2.5	95	205	2	M16	32	16	14	155	17.5	95	M16x45	4	65
PH/PB8...	150	162	2.5	110	204	2	M16	32	16	16	170	17.5	110	M16x45	4	85
PH/PB9...	160	176	4.0	110	235	3	M16	32	16	16	190	17.5	110	M16x45	4	115
PH/PB10...	180	196	4.0	145	235	3	M20	38	16	18	215	22	145	M20x55	4	130
PH/PB11...	200	216	4.0	145	275	3	M20	38	16	18	230	22	145	M20x55	4	175
PH/PB12...	210	230	4.0	160	275	3	M20	38	16	18	250	22	160	M20x55	4	200

Kama, teslimat kapsamına dahil değildir. İhtiyaç olması durumunda, ayrıca sipariş edilmelidir

- 1) Cıvatalar, DIN 931'e uygun ve malzemesi 10.9 olmalıdır; somunlar, DIN 934'e uygun ve malzemesi 10.9 olmalıdır.
- 2) Flanş bağlantı civatasının sıkma torku Flanş ve müşteri millerinin malzeme mukavemet değeri, C60N veya üstü olmalıdır.

Parallel key does not belong to our scope of supply. Please order separately, if required.

- 1) Bolts acc. to DIN 931, material 10.9; Nuts acc. to DIN 934, material 10.9
- 2) Tightening torque of flange connection bolts Material of flanges and driven machine shafts: C60N or higher strength

Passfeder gehört nicht zum Lieferumfang. Bei Bedarf gesondert bestellen.

- 1) Schrauben nach DIN 931, Werkstoff 10.9; Muttern nach DIN 934, Werkstoff 10.9
- 2) Anzugsmoment der Flanschverbindungsschraube Werkstoffe der Flansche und Arbeitsmaschinenwellen C60N oder höhere Festigkeit.

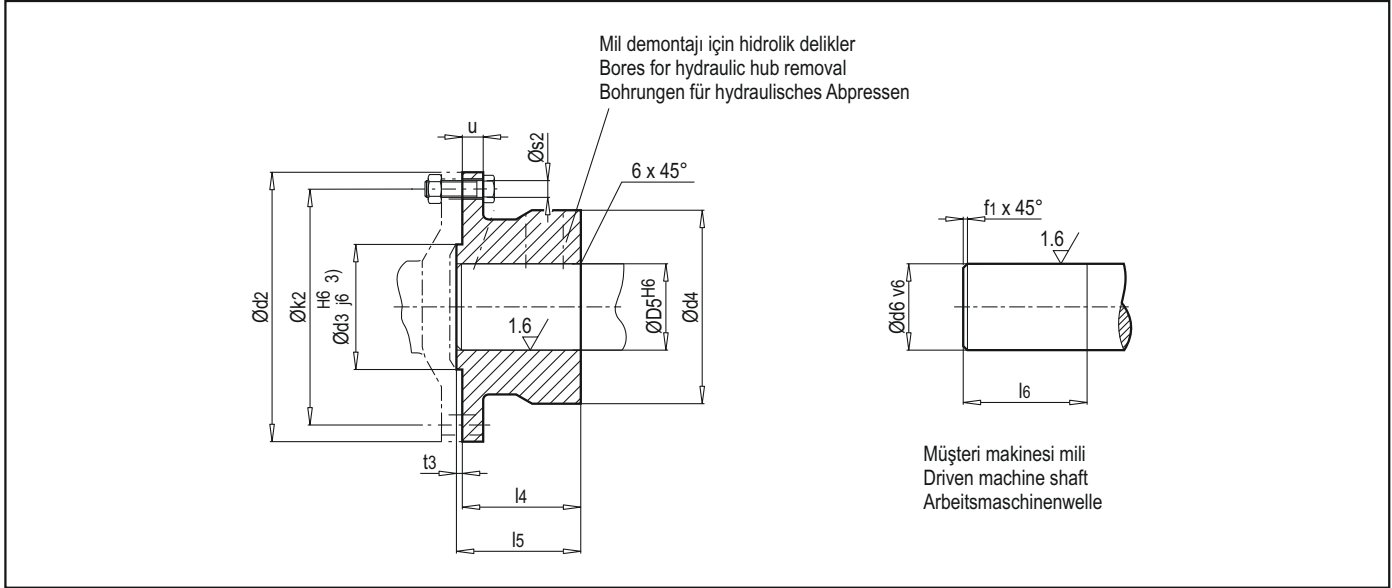

Tipler / Types / Bauarten PH...2F, PH...3F, PH...4F, PB...2F, PB...3F, PB...4F

Redüktör Gövdesi Gear unit size Getriebe- größen	Flanş / Flange / Flansch 2)										Cıvata 1) Bolt Schraube			Müşteri makinesi mili Driven machine shaft Arbeitsmaschinenwelle			Ağırlık Weight Gewicht kg
	Ød2	Ød3	Ød4	ØD5	Øk2	l4	l5	Øs2	t3	u	Boyut Size Größe	Adet Qty Anzahl	Ta Nm	Ød6	f1	l6	
	mm													mm			
PH/PB13...	580	310	391	240	500	310	322	M30	12	48	M30x130	20	2100	240	3	322	235
PH/PB14...	620	310	426	260	540	345	357	M30	12	48	M30x130	24	2100	260	3	357	300
PH/PB15...	710	360	461	280	630	365	380	M30	15	55	M30x140	28	2100	280	3	380	400
PH/PB16...	740	360	481	300	660	395	410	M30	15	55	M30x140	30	2100	300	4	410	450
PH/PB17...	750	410	521	320	660	420	436	M36	16	60	M36x160	24	3560	320	4	436	540
PH/PB18...	800	410	551	340	710	450	466	M36	16	60	M36x160	26	3560	340	4	466	650
PH/PB19... PH/PB20... PH/PB21... PH/PB22...	Talep edildiğinde / On request / Auf Anfrage																

- 1) Cıvatalar, DIN 931'e uygun ve malzemesi 10.9 olmalıdır; somunlar, DIN 934'e uygun ve malzemesi 10.9 olmalıdır.
- 2) Diğer çaplar, talep üzerine temin edilir. (Taban/ayak için, daha küçük D5 deliklerin uygulanması da mümkündür).
- 3) Sıkıştırmadan sonraki ölçü d3 j6'dır.
Kama kanallı flanş bağlantısı, talep edildiğinde temin edilir. Flanş ve müşteri millerinin malzeme mukavemet değeri, C60N veya üstü olmalıdır. Kontra flanş 190°C'ye ve müşteri mili 20°C'ye ısıtılarak yerleştirilir.

- 1) Bolts acc.to DIN 931, material 10.9; Nuts acc. to DIN 934, material 10.9
- 2) Other diameters on request. (for footmounted design, smaller bores D5 are possible)
- 3) Dimension d3 j6 after shrink fitting.
Counterflange with keyway on request. Material of flanges and driven machine shafts: C60N or higher strengths. For assembly, heat counterflange to 190°C, and driven machine shaft to 20°C.

- 1) Schrauben nach DIN 931, Werkstoff 10.9; Muttern nach DIN 934, Werkstoff 10.9
- 2) Andere Durchmesser auf Anfrage. (Bei Fußausführung sind kleinere Bohrungen D5 möglich).
- 3) Maß d3 j6 nach dem Aufschrumpfen.
Flanschverbindung mit passfedernut auf Anfrage. Werkstoffe der Flansche und Arbeitsmaschinenwellen C60N oder höhere Festigkeiten. Gegenflansch beim Aufsetzen auf 190°C erwärmen, Arbeitsmaschinenwelle auf 20°C.

TR YAĞ SEÇİMİ VE MUHAFAZA

EN SELECTION OF OIL AND PRESERVATION

DE ÖLAUSWAHL UND KONSERVIERUNG

PGR dişli redüktörleri, PGR tarafından önerilen yağ firmalarının önerilen yağları kullanılarak doldurulur, işbu kapsamda ilgili yağ tipi ve yağ viskozitesine ilişkin yağ firmaları ve benzer şekilde yağ tedarikçisi firmalar, Tablo 1’de belirtilen uygulama sınırlamalarına dikkat etmelidir.

Tablo 2’de, ilgili redüktör tipi ve boyutuna göre uygulanması mümkün olan yağlama şekillerine ilişkin genel bilgiler yer almaktadır.

25 cSt’lik asgari çalışma viskozitesi, mutlaka sağlanmalıdır.

PGR gear units may be filled with oils from producer authorized by PGR, the oil producer or supplier being responsible for the quality of his product. For the selection of oil grade and viscosity, the limits of application given in table 1 are to be taken into consideration.

In table 2 a survey of the possible oil supply variants is given for the respective types and sizes.

A minimum operating viscosity of 25 cSt must be ensured.

PGR Zahnratgetriebe können mit Ölen von PGR zugelassener Hersteller befüllt werden, wobei der Ölhersteller bzw. Öllieferant für die Qualität seines Produktes verantwortlich ist. Bei der Auswahl von Ölart und Ölviskosität sind die in der Tabelle 1 genannten Einsatzgrenzen zu beachten.

Die Tabelle 2 gibt einen Überblick über die möglichen Ölversorgungsvarianten für die entsprechenden Bauarten und Größen.

Eine Mindest - Betriebsviskosität von 25 cSt muss gewährleistet sein.

Tablo 1 / Table 1 / Tabelle 1				
40°C’deki viskozitesi mm ² /s (cSt) Viscosity ISO - VG at 40 °C in mm ² /s (cSt) Viskosität ISO- VG bei 40 °C in mm ² /s (cSt)	Minimum sıcaklık sınırı °C Minimum temperature limit in °C for Miniale Grenztemperaturen in °C für			
	Daldırma yağlama Dip lubrication Tauchschnierung		Basıncılı yağlama Forced lubrication Druckschnierung	
	Mineral yağ Mineral oil Mineralöl	Sentetik yağ *) Synthetic oil Synthetisches Öl	Mineral yağ Mineral oil Mineralöl	Sentetik yağ *) Synthetic oil Synthetisches Öl
VG 220	- 15	- 25	10	0
VG 320	- 12	- 25	15	5
VG 460	- 10	- 25	-	-

*) PG bazlı sentetik yağ kullanmadan önce, mutlaka PGR ile görüşün!

*) If synthetic oil on PG basis is used, please consult PGR !

*) Bei Einsatz von synthetischem Öl Auf PG Basis bitte Rücksprache mit PGR!

Daldırma yağlama:

Daldırma yöntemiyle yağlamada, yağlanacak tüm parçalar yağ içerisinde konur.

Yağ genişemesi için, bir yağ tankı vidalanarak bağlanır.

Seçim kriterleri için, sayfa 139’a bakın.

Mutlaka tabloda belirtilen sıcaklıklara göre, ısıtılmalıdır.

Daldırma yöntemiyle yağlamada, yağ sıcaklığı seçilen yağ tipinin akma noktasının altında olmamalıdır.

Basıncılı yağlama:

Basıncılı yağlamada, yağ içerisinde olmayan tüm parçalar, bağlanacak bir flanş pompası veya ayrı bir motor pompası vasıtasıyla, püskürtme yağlama yöntemiyle yağlanır. Seçim kriterleri için, 140-143 arasındaki sayfalara bakın.

Basıncılı yağlama uygulandığında, hareket sırasında 1800cSt’lik çalışma viskozitesi değeri aşılmamalıdır.

Daldırma yöntemiyle yağlamada, Tablo 1’de listelenen sıcaklık sınırlarına, mutlaka uyulmalıdır veya ısıtılmalıdır.

Dip lubrication:

In case of dip lubrication, all parts to be lubricated are lying in the oil.

An oil expansion tank has been fitted for oil expansion.

For criteria for selection, see pages 139.

If the temperatures are below the values as listed in the table, the oil must be heated.

In case of dip lubrication, the oil temperature must not drop below the pour point of the selected oil.

Forced Lubrication:

In case of forced lubrication, all parts not lying in oil are splash lubricated by means of a flanged-on-pump or by a separate motor pump.

For criteria for selection, see pages 140-143.

In case of forced lubrication, the operating viscosity 1800 cSt must not be exceeded during start-up.

If the temperatures are below the values as listed in table 1, dip lubrication has to be provided or the oil must be heated.

Tauchschnierung:

Bei Tauchschnierung liegen alle zu schmierenden Elemente in Öl.

Ein Ölausgleichsbehälter ist für die Ölausdehnung angeschraubt.

Auswahlkriterien siehe Seite 139

Unterhalb der in der Tabelle angegebenen Temperaturen muss beheizt werden.

Bei Tauchschnierung darf die Öltemperatur nicht unterhalb des Pourpoints des gewählten Öles liegen.

Druckschnierung:

Bei Druckschnierung werden alle nicht in Öl liegenden Elemente durch eine angebaute Flanscpumpe oder durch eine separate Motorpumpe mit Spritzöl versorgt.

Auswahlkriterien siehe Seiten 140-143.

Bei Druckschnierung darf die Betriebsviskosität 1800 cSt beim Anfahren nicht überschritten werden.

Unterhalb der in Tabelle 1 aufgeführten Grenztemperaturen ist tauchschnierung vorzusehen oder es muss beheizt werden.

Muhafaza:

PGR redüktörlerinin iç kısımlarının korozyona karşı muhafazası, kullanılan yağ tipine bağlıdır.

Korozyona karşı korunmuş redüktörlerin, aşağıda belirtilen sürelerde depolanması mümkündür:

Standart Muhafaza	Uzun süreli Muhafaza ¹⁾
6 aya kadar	24 aya kadar ²⁾ 36 aya kadar ³⁾

1) Yukarıda belirtilen süreler, labirent veya diyafram keçeli redüktörler için geçerli değildir.

2) Sadece mineral yağ veya PAO bazlı sentetik yağ kullanıldığında geçerlidir.

3) Sadece PG bazlı sentetik yağ kullanıldığında geçerlidir.

Yukarıda belirtilen depolama süreleri aşıldığında, redüktörle yeniden korozyona karşı muhafaza uygulanır.

Preservation:

The internal preservation of PGR gear units is dependent on the oil used.

For gear units with corrosion prevention, the following storage times are possible:

Standard preservation	Long-term preservation ¹⁾
up to 6 months	up to 24 months ²⁾ up to 36 months ³⁾

1) Not for gear units with labyrinth seals or diaphragm glands.

2) Only if mineral oil or Synthetic oil on PAO basis is used.

3) Only if synthetic oil on PG basis is used.

If the storage periods mentioned are exceeded, the anticorrosive agent in the gear unit is to be renewed.

Konservierung:

Die Innenkonservierung von PGR -Zahnradgetrieben ist abhängig von dem zum Einsatz kommenden Öl.

Für konverzierte Getriebe sind folgende Lagerzeiten möglich:

Standard-Konservierung	Langzeit-Konservierung ¹⁾
bis 6 Monate	bis 24 Monate ²⁾ bis 36 Monate ³⁾

1) nicht für Getriebe mit Labyrinth- oder Spaltdichtung.

2) nur bei Einsatz von Mineralöl oder synthetischem Öl auf PAO-Basis.

3) nur bei Einsatz von synthetischem Öl auf PG-Basis.

Bei Überschreitung der genannten Lagerzeiten ist das Getriebe erneut zu konservieren.

Tablo 2 / Table 2 / Tabelle 2				
Tip Type Bauart	Gövde Size Größe	Daldırma yağlama Dip lubrication Tauchschmierung	Flanşlı pompa ile basınçlı yağlama Forced lubrication, flanged-on pump Druckschmierung Flanschpumpe	Motorlu pompa ile basınçlı yağlama Forced lubrication, motor pump Druckschmierung Motorpumpe
PH...1-SH	31 - 171	H	H	-
PH...2	42	H V	V	-
	52 - 122	H V	H V SR 1) 3)	-
	132 - 182	H M	H M V SR 1) 3)	-
	192 - 222	H M	V	-
PH...3	53 - 123	H V	V SR 1)	V SR 1)
	133 - 183	H M	V SR 1)	V SR 1)
	193 - 223	H M	V	-
PH...4	74 - 124	H V	V	V
	134 - 184	H M	V	V
	194 - 224	H M	V	-
PB...2	42	H V	V	-
	52 - 122	H V	H V SR 2)	V SR 2)
	132 - 182	H M	H M V SR 2)	V SR 2)
	192 - 222	H M	V	-
PB...3	43	H V	V	-
	53 - 123	H V	V SR 2)	V SR 2)
	133 - 183	H M	V SR 2)	V SR 2)
	193 - 223	H M	V	-
PB...4	54 - 124	H V	V SR 2)	V SR 2)
	134 - 184	H M	V SR 2)	V SR 2)
	194 - 224	H M	V	-

H = Yatay redüktör
M = Şaft montajlı yatay redüktörler
V = Dikey redüktör
SR = Çıkış mili ve yağ tüplü dikey redüktör

H = Horizontal gear unit
M = Shaft-mounted horizontal gear unit
V = Vertical gear unit
SR = Vertical gear unit with solid output shaft and oil retaining tube

H = Horizontalgetriebe
M = Horizontalgetriebe in Aufsteckausführung
V = Vertikalgetriebe
SR = Vertikalgetriebe mit Abtriebsvollwelle und Ölstaurohr

- 1) Sadece B tasarımı için mümkün
2) Sadece C tasarımı için mümkün
3) Gövde 5 için mümkün olan $i \leq 16$
Gövde 7 için mümkün olan $i \leq 16$
Gövde 11 için mümkün olan $i \leq 18$
Gövde 13 için mümkün olan $i \leq 18$
Gövde 17 için mümkün olan $i \leq 18$

- 1) Design B possible only
2) Design C possible only
3) For size 5 only possible up to $i \leq 16$
For size 7 only possible up to $i \leq 16$
For size 11 only possible up to $i \leq 18$
For size 13 only possible up to $i \leq 18$
For size 17 only possible up to $i \leq 16$

- 1) Nur Ausführung B möglich
2) Nur Ausführung C möglich
3) Größe 5 nur bis $i \leq 16$ möglich
Größe 7 nur bis $i \leq 16$ möglich
Größe 11 nur bis $i \leq 18$ möglich
Größe 13 nur bis $i \leq 18$ möglich
Größe 17 nur bis $i \leq 16$ möglich

TR DALDIRMA YÖNTEMİYLE YAĞLAMA - DİKEY

EN DIP LUBRICATION - VERTICAL

DE TAUCHSCHMIERUNG - VERTIKAL

Daldırma yöntemiyle yağlama uygulandığında, aşağıda belirtilen kriterlere dikkat edilmelidir:

- a) Maksimum giriş devir sayıları için, tablo 3'e bakın.
b) İzin verilen yağ sıcaklıkları için, tablo 1'e bakın.

Tablo 3'te belirtilmemiş n_1 ve $\dot{I}N$ değerlerine sahip redüktörlerin termal değerleri, bu katalogta belirtilen parametre ve değerlerden farklı olabilir.

Gerekirse, bu tip redüktörlere basınçlı yağlama uygulanmalıdır.

Lütfen PGR ile görüşünüz!

For the design with dip lubrication the following criteria are to be taken into account:

- a) For maximum input speed n_1 , see table 3.
b) For permissible oil temperatures, see table 1.

For gear units with n_1 and $\dot{I}N$ not listed in table 3, the parameters for the calculation of the thermal capacity can deviate from those given in this brochure.

If necessary, such gear units are to be designed with forced lubrication.

Please consult PGR!

Bei der Auslegung der Tauchschmierung sind folgende Kriterien zu berücksichtigen:

- a) maximale Eingangsdrehzahl n_1 siehe Tabelle 3.
b) zulässige Öltemperaturen siehe Tabelle 1.

Bei Getrieben mit n_1 und $\dot{I}N$, die nicht in der Tabelle 3 aufgeführt sind, kann die thermische Auslegung von den in diesem Katalog genannten Parametern abweichen.

Gegebenenfalls sind diese Getriebe mit einer Druckschmierung auszuführen.

Hier ist Rücksprache mit PGR notwendig!

Tablo 3 / Table 3 / Tabelle 3

Gövde Size Größe	Tipler / Types / Bauarten											
	PH..2-V		PH..3-V		PH..4-V		PB..2-V		PB..3-V		PB..4-V	
	$\dot{I}N$	n_{1max} min ⁻¹	$\dot{I}N$	n_{1max} min ⁻¹	$\dot{I}N$	n_{1max} min ⁻¹	$\dot{I}N$	n_{1max} min ⁻¹	$\dot{I}N$	n_{1max} min ⁻¹	$\dot{I}N$	n_{1max} min ⁻¹
PH/PB4...	6.3 - 10 11.2 - 12.5 14 - 22.4	1200 1500 1800	-	-	-	-	5 - 5.6 6.3 - 7.1 8 - 9 10 - 11.2	750 900 1000 1200	12.5 - 71	1800	-	-
PH/PB5...	6.3 - 9 10 - 12.5 14 - 16 18 - 22.4	1000 1200 1500 1800	25 - 90	1800	-	-	6.3 - 7.1 8 - 9 10 - 11.2	750 900 1000	12.5 - 71	1800	80 - 315	1800
PH/PB6...	8 - 11.2 12.5 - 16 18 - 20 22.4 - 28	1000 1200 1500 1800	31.5 - 112	1800	-	-	9 10 - 11.2 12.5 - 14	750 900 1000	16 - 90	1800	100 - 400	1800
PH/PB7...	6.3 - 7.1 8 - 9 10 - 11.2 12.5 - 16 18 - 22.4	750 900 1000 1200 1500	25 - 90	1800	100 - 355	1800	9 - 10 11.2	750 900	12.5 - 25 28 - 71	1500 1800	80 - 315	1800
PH/PB8...	8 - 9 10 - 11.2 12.5 - 14 16 - 20 22.4 - 28	750 900 1000 1200 1500	31.5 - 112	1800	125 - 450	1800	11.2 - 12.5 14	750 900	16 - 31.5 35.5 - 90	1500 1800	100 - 400	1800
PH/PB9...	6.3 - 7.1 8 - 10 11.2 - 22.4	1200 1500 1800	25 - 90	1800	100 - 355	1800	5 - 5.6 6.3 - 7.1 8 - 10 11.2	900 1000 1200 1500	12.5 - 71	1800	80 - 315	1800
PH/PB10...	8 - 9 10 - 12.5 14 - 28	1200 1500 1800	31.5 - 112	1800	125 - 450	1800	6.3 - 7.1 8 - 9 10 - 12.5 14	900 1000 1200 1500	16 - 90	1800	100 - 400	1800
PH/PB11...	6.3 - 7.1 8 - 10 11.2 - 12.5 14 - 22.4	1000 1200 1500 1800	25 - 90	1800	100 - 355	1800	5.6 - 6.3 7.1 - 8 9 - 10 11.2	750 900 1000 1200	12.5 - 22.4 25 - 71	1500 1800	80 - 315	1800
PH/PB12...	8 - 9 10 - 12.5 14 - 16 18 - 28	1000 1200 1500 1800	31.5 - 112	1800	125 - 450	1800	7.1 - 8 9 - 10 11.2 - 12.5 14	750 900 1000 1200	16 - 28 31.5 - 90	1500 1800	100 - 400	1800

TR BASINÇLI YAĞLAMA FLANŞLI POMPA

EN FORCED LUBRICATION - FLANGED ON PUMP

DE DRUCKSCHMIERUNG - FLANSCHPUMPE

Tablo 4 / Table 4 / Tabelle 4

Helisel dişli dikey redüktörde flanş pompası uygulaması
Assignment of flanged-on pumps to vertical helical gear units / Flanshpumpenzuordnung für Stirnrad - Vertikalgetriebe

Tip Type Bauart	n1 min ⁻¹	Redüktör boyutları Gear unit size Getriebegröße		Flanşlı pompa boyutu Flanged-on pump size Flansch- Pumpengröße	Redüktör boyutları Gear unit size Getriebegröße			Flanşlı pompa boyutu Flanged-on pump size Flansch- Pumpengröße
		5,7,9,11	6,8,10,12		13,15,17	14	16,18	
		Tahvil / Ratio / Übersetzung iN			Tahvil / Ratio / Übersetzung iN			
PH...2-V A,C	750 - 1800	6.3 - 22.4	8 - 28	KSW 1	6.3 - 22.4	8 - 28	7.1 - 25	KSW 2
PH...3-V A,C	1201 - 1800	25 - 40	31.5 - 50	KSW 2	22.4 - 50	28 - 63	25 - 56	KSW 3
		45 - 90	56 - 112	KSW 3	56 - 90	71 - 112	63 - 90	KSW 4
							100	*
	901 - 1200	25 - 56	31.5 - 71	KSW 3	22.4 - 31.5	28 - 40	25 - 35.5	KSW 3
		63 - 90	80 - 112	*	35.5 - 56	45 - 71	40 - 63	KSW 4
					63 - 90	80 - 112	71 - 100	*
750 - 900	25 - 45	31.5 - 56	KSW 3	22.4 - 25	28 - 31.5	25 - 28	KSW 3	
	50 - 90	63 - 112	*	28 - 45	35.5 - 56	31.5 - 50	KSW 4	
				50 - 90	63 - 112	56 - 100	*	
PH...4-V A,C	1201 - 1800	100 - 224	125 - 280	KSW 3	100 - 355	125 - 450	112 - 400	*
		250 - 355	315 - 450	*				
	901 - 1200	100 - 140	125 - 180	KSW 3				
		160 - 355	200 - 450	*				
		750 - 900	100 - 112	125 - 140				
125 - 355	160 - 450		*					
PH...2-V B,D	750 - 1800	6.3 - 22.4	8 - 28	KSW 1	6.3 - 22.4	8 - 28	7.1 - 25	KSW 2
PH...3-V B,D	1201 - 1800	25 - 35.5	31.5 - 45	KSW 2	22.4 - 35.5	28 - 45	25 - 40	KSW 3
		40 - 71	50 - 90	KSW 3	40 - 71	50 - 90	45 - 80	KSW 4
		80 - 90	100 - 112	*	80 - 90	100 - 112	90 - 100	*
	901 - 1200	25 - 50	31.5 - 63	KSW 3	22.4 - 25	28 - 31,5	25 - 28	KSW 3
		56 - 90	71 - 112	*	28 - 45	35.5 - 56	31.5 - 50	KSW 4
					50 - 90	63 - 112	56 - 100	*
750 - 900	25 - 35.5	31.5 - 45	KSW 3	22.4 - 35.5	28 - 45	25 - 40	KSW 4	
	40 - 90	50 - 112	*	40 - 90	50 - 112	45 - 100	*	
PH...4-V B,D	1201 - 1800	100 - 180	125 - 224	KSW 3	100 - 355	125 - 450	112 - 400	*
		200 - 355	250 - 450	*				
	901 - 1200	100 - 125	125 - 160	KSW 3				
		140 - 355	180 - 450	*				
		750 - 900	100 - 355	125 - 450				

* Motor pompası büyüklüğü için, Tablo 6'ya bakın. / Motor pump required, see table 6 / Motorpumpe erforderlich siehe Tabelle 6

TR BASINÇLI YAĞLAMA FLANŞLI POMPA

EN FORCED LUBRICATION - FLANGED ON PUMP

DE DRUCKSCHMIERUNG - FLANSCHPUMPE

Tablo 5 / Table 5 / Tabelle 5

Helisel-konik dişli dikey redüktörde flanşlı pompası uygulaması
Assignment of flanged-on pumps to vertical bevel - helical gear units / Flanshpumpenzuordnung für Kegelmotorrad - Vertikalgetriebe

Tip Type Bauart	n1 min ⁻¹	Redüktör boyutları Gear unit size Getriebegröße		Flanşlı pompa boyutu Flanged-on pump size Flansch- pumpengröße	Redüktör boyutları Gear unit size Getriebegröße			Flanşlı pompa boyutu Flanged-on pump size Flansch- pumpengröße
		5,7,9,11	6,8,10,12		13,15,17	14	16,18	
		Tahvil / Ratio / Übersetzung iN			Tahvil / Ratio / Übersetzung iN			
PB...2-V A,B	1201 - 1800	5 - 6.3	6.3 - 8	KSW 1	5 - 8	6.3 - 10	5.6 - 9	KSW 2
		7.1 - 11.2	9 - 14	KSW 2	9 - 11.2	11.2 - 14	10 - 12.5	KSW 3
	901 - 1200	5 - 8	6.3 - 10	KSW 2	5	6.3	5.6	KSW 2
		9 - 11.2	11.2 - 14	KSW 3	5.6 - 11.2	7.1 - 14	6.3 - 12.5	KSW 3
	750 - 900	5 - 6.3	6.3 - 8	KSW 2	5 - 10	6.3 - 12.5	5.6 - 11.2	KSW 3
		7.1 - 10	9 - 12.5	KSW 3	11.2	14	12.5	*
		11.2	14	*				
PB...2-V C,D	1201 - 1800	5 - 6.3	6.3 - 8	KSW 1	5 - 6.3	6.3 - 8	5.6 - 7.1	KSW 2
		7.1 - 11.2	9 - 14	KSW 2	7.1 - 11.2	9 - 14	8 - 12.5	KSW 3
	901 - 1200	5 - 8	6.3 - 10	KSW 2	5 - 10	6.3 - 12.5	5.6 - 11.2	KSW 3
		9 - 11.2	11.2 - 14	KSW 3	11.2	14	12.5	*
	750 - 900	5 - 6.3	6.3 - 8	KSW 2	5 - 7.1	6.3 - 9	5.6 - 8	KSW 3
		7.1 - 10	9 - 12.5	KSW 3	8 - 11.2	10 - 14	9 - 12.5	*
		11.2	14	*				
PB...3-V A,B	1201 - 1800	12.5 - 35.5	16 - 45	KSW 2	12.5 - 22.4	16 - 28	14 - 25	KSW 2
		40 - 71	50 - 90	KSW 3	25 - 50	31.5 - 63	28 - 56	KSW 3
					56 - 71	71 - 90	63 - 80	KSW 4
	901 - 1200	12.5 - 25	16 - 31.5	KSW 2	12.5 - 35.5	16 - 45	14 - 40	KSW 3
		28 - 50	35.5 - 63	KSW 3	40 - 56	50 - 71	45 - 63	KSW 4
	750 - 900	56 - 71	71 - 90	*	63 - 71	80 - 90	71 - 80	*
12.5 - 35.5		16 - 45	KSW 3	12.5 - 25	16 - 31.5	14 - 28	KSW 3	
		40 - 71	50 - 90	*	28 - 40	35.5 - 50	31.5 - 45	KSW 4
					45 - 71	56 - 90	50 - 80	*
PB...3-V C,D	1201 - 1800	12.5 - 35.5	16 - 45	KSW 2	12.5 - 35.5	16 - 45	14 - 40	KSW 3
		40 - 71	50 - 90	KSW 3	40 - 71	50 - 90	45 - 80	KSW 4
	901 - 1200	12.5 - 25	16 - 31.5	KSW 2	12.5 - 25	16 - 31.5	14 - 28	KSW 3
		28 - 50	35.5 - 63	KSW 3	28 - 50	35.5 - 63	31.5 - 56	KSW 4
	750 - 900	56 - 71	71 - 90	*	56 - 71	71 - 90	63 - 80	*
		12.5 - 35.5	16 - 45	KSW 3	12.5 - 35.5	16 - 45	14 - 40	KSW 4
		40 - 71	50 - 90	*	40 - 71	50 - 90	45 - 80	*
PB...4-V A,B	1201 - 1800	80 - 125	100 - 160	KSW 2	80 - 315	100 - 400	90 - 355	*
		140 - 250	180 - 315	KSW 3				
		280 - 315	355 - 400	*				
	901 - 1200	80 - 180	100 - 224	KSW 3				
		200 - 315	250 - 400	*				
	750 - 900	80 - 125	100 - 160	KSW 3				
140 - 315		180 - 400	*					
PB...4-V C,D	1201 - 1800	80 - 180	100 - 224	KSW 3	80 - 315	100 - 400	90 - 355	*
		200 - 315	250 - 400	*				
	901 - 1200	80 - 125	100 - 160	KSW 3				
		140 - 315	180 - 400	*				
	750 - 900	80 - 90	100 - 112	KSW 3				
		100 - 315	125 - 400	*				

* Motorlu pompa gerekli, tablo 7'ye bakınız / Motor pump required, see table 7 / Motorpumpe erforderlich siehe Tabelle 7

TR BASINÇLI YAĞLAMA MOTORLU POMPA

EN FORCED LUBRICATION - MOTOR PUMP

DE DRUCKSCHMIERUNG - MOTORPUMPE

Tablo 6 / Table 6 / Tabelle 6			
Helisel dişli dikey redüktörde motor pompası uygulaması Assignment of motor pumps to vertical helical gear units / Motorpumpenzuordnung für Stirnrad - Vertikalgetriebe			
Tip / Type / Bauart	Gövde / Size / Größe	Dizayn / Design / Ausführung	Pompa / Pump / Pumpe
PH...2-V	52 - 182	A / B / C / D	1)
PH...3-V	53 - 183	A / C	SF 2/8
	53 - 123	B / D	SF 2/8
	133 - 183		SF 2/13
PH...4-V	74 - 124	A / C	SF 2/8
	134 - 184		SF 2/13
	74 - 184	B / D	SF 2/13

1) Sadece flanşlı pompa

1) Flanged-on pump only

1) nur Flanscpumpe

Tablo 7 / Table 7 / Tabelle 7			
Helisel - konik dişli dikey redüktörde motor pompası uygulaması Assignment of motor pumps to vertical bevel- helical gear units / Motorpumpenzuordnung für Kegelstirnrad - Vertikalgetriebe			
Tip / Type / Bauart	Gövde / Size / Größe	Dizayn / Design / Ausführung	Pompa / Pump / Pumpe
PB...2-V	52 - 122	A / B	SF 2/5
	132 - 182		SF 2/8
	52 - 182	C / D	SF 2/8
PB...3-V	53 - 123	A / B	SF 2/8
	133 - 183		SF 2/13
	53 - 123	C / D	SF 2/8
	133 - 183		SF 2/13
PB...4-V	54 - 124	A / B	SF 2/8
	134 - 184		SF 2/13
	54 - 124	C / D	SF 2/8
	134 - 184		SF 2/13

TR

**BASINÇLI YAĞLAMA -
KONTROL CİHAZLARI**

Motor veya flanş pompasıyla basınçlı yağlama uygulandığında kullanılan kontrol cihazları.

EN

**FORCED LUBRICATION -
MONITORING INSTRUMENTS**

Monitoring instruments for forced lubrication by means of flanged-on or motor pump.

DE

**DRUCKSCHMIERUNG -
ÜBERWACHUNGSGERÄTE**

Überwachungsgeräte bei Druckschmierung durch Flansch oder Motorpumpe

Redüktör Gövdeleri Gear Unit Size Getriebegröße 5 - 12	Redüktör Gövdeleri Gear Unit Size Getriebegröße 5 - 12
a) Kaba filtre Coarse filter Grobfilter	a) Çifte filtre Double change- over filter Doppelschaltfilter
b) Basınç göstergesi Pressure monitor Druckwächer	a) Basınç göstergesi Pressure monitor Druckwächer
	c) Basınç göstergesi için bağlantı G 1/2 Connection for pressure gauge G 1/2 Anschluß Manometer G 1/2

a) **Kaba filtre:** Akışla birlikte gelen kir ve pisliklerin tutulmasını sağlar.

Çift geçiş filtresi yerleştirilmiş uygulamanın, elektrikli optik kirlilik göstergesi vardır.
Basınç farkı "Δp" = 2 bar, 1 çevirme anahtarlı.

Maximum elektrik değerleri:
Çalışma Gerilimi: U ≤ 250 V DC + AC
Çalışma Akım Şiddeti I ≤ 1A
Kumanda kapasitesi: P ≤ 30W veya ≤ 60 VA
Koruma Sınıfı: IP 65

b) Yağ basıncı, < 0,5 barın altına düşmesi halinde optik veya sesli bir alarm verecek veya makineyi kapatacak bir sisteme bağlanabilir

Teknik Bilgiler:
Maks. çalışma kapasitesi
2 A/250 V, AC/250 VA (alternatif akım)
4 A/200 V, DC/20 W (doğru akım)
Koruma sınıfı tipi IP 65 tipi

a) **Coarse filters** serve to protect downstream units by catching and collecting dirt particles.

Double change - over filters with opposed cylinders have an opto-electrical contamination indicator.
Differential pressure Δp = 2 bar, 1 changeover contact.

Electrical maximum ratings:
Switching voltage U ≤ 250 V DC + AC
Switching current I ≤ 1A
Switching capability P ≤ 30W or ≤ 60 VA
Type of protection IP 65

b) when the oil pressure drops below 0.5 bar, the **pressure monitor** in combination with a warning system can give an optical or acoustical warning, or switch off the system.

Technical Data:
Max. switching capacity
2 A/250 V, AC/250 VA (alternating current)
4 A/200 V, DC/20 W (direct current)
Type of protection IP 65

a) **Grobfilter** dienen dem Schutz von nachgeschalteten Aggregaten durch Auffangen und Sammeln von Schmutzpartikeln.

Doppelschaltfilter in Boxer - Ausführung haben eine optisch / elektrische Verschmutzungsanzeige.
Differenzdruck Δp= 2 bar, 1 Umschaltkontakt.

Elektrische Grenzdaten:
Schaltspannung U ≤ 250 V DC + AC
Schaltstrom I ≤ 1A
Schaltvermögen P ≤ 30W bzw. ≤ 60 VA
Schutzart IP 65

b) Der **Druckwächer** kann in Verbindung mit einer Warnanlage das Absinken des Öldruckes ≤ 0,5 bar optisch oder akustisch anzeigen oder die Anlage ausschalten.

Technische Daten:
Max. Schaltleistungen
2 A/250 V, AC/250 VA (Wechselspannung)
4 A/200 V, DC/20 W Gleichspannung)
Schutzart IP 65

Gövdeler / Sizes / Größen
51 - 121

Basıncın 0.5 barın altında
Pressure monitor, below 0.5 bar
Druckwächter 0.5 bar fallend

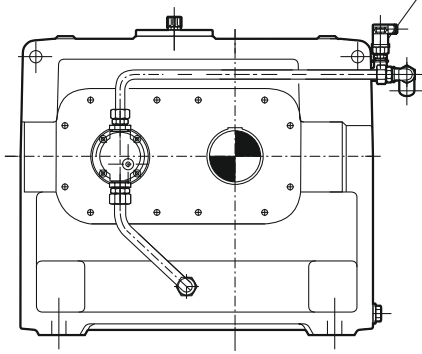

Gövdeler / Sizes / Größen
131 - 171

Basıncın 0.5 barın altında
Pressure monitor, below 0.5 bar
Druckwächter 0.5 bar fallend

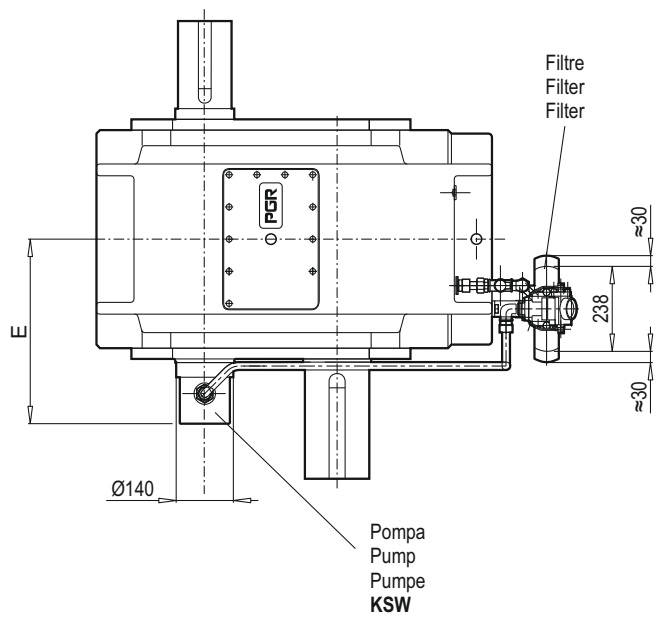
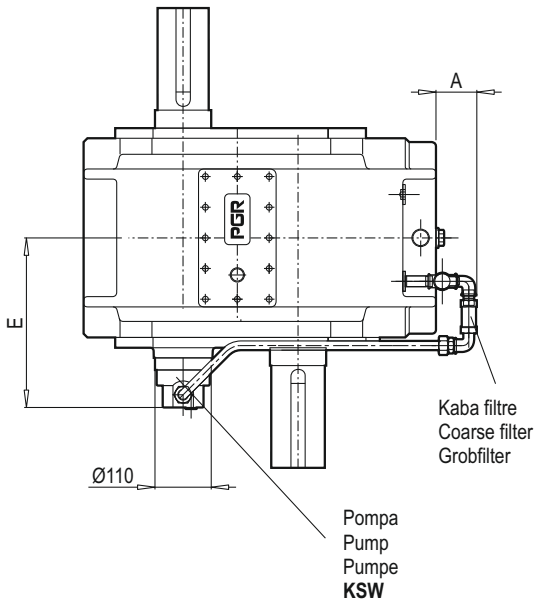
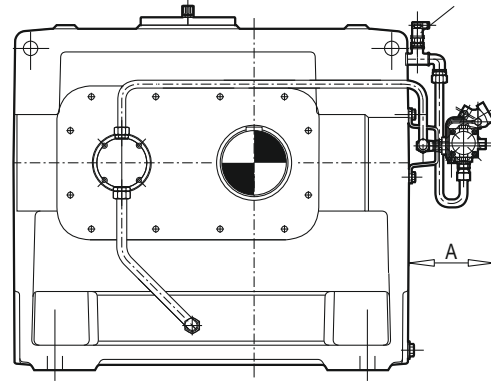

Zemin düz ve yatay olmalıdır.
Talep edildiğinde eğik pozisyon.

The foundation must be flat and horizontal.
Inclined position on request.

Fundament muss waagrecht und eben sein,
Schräglage auf Anfrage.

Tablo 9 / Table 9 / Tabelle 9

Redüktör boyutu Gear unit size Getriebe Größen	51	71	91	111	131	151	171		
Pompa* Pump / Pumpe KSW	1	2	2	2	3	3	3	3	3
A mm	≈ 115	≈ 105	≈ 105	≈ 125	≈ 240	≈ 240	≈ 240	≈ 240	≈ 240
E mm	285	340	405	435	480	485	$i_N = 3.15 - 4$ 525	$i_N = 4.5 - 5.6$ 525	$i_N = 2 - 2.8$ 525

*) Geçerli olan devir sayıları:
 $n_1 > 1500$ ile 1800 d/d arası

*) Applies to speeds:
 $n_1 \geq 900$ up to 1800 min⁻¹

*) Gültig für Drehzahlen:
 $n_1 \geq 900$ bis 1800 min⁻¹

Gövdeler / Sizes / Größen
52 - 122

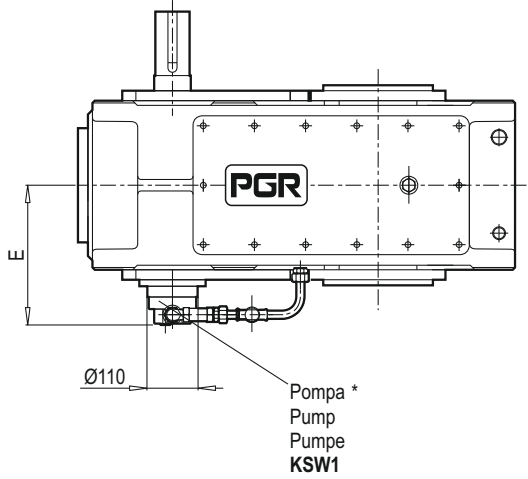
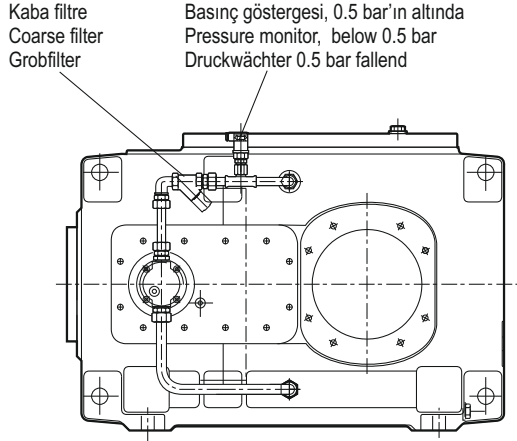

Gövdeler / Sizes / Größen
132 - 182

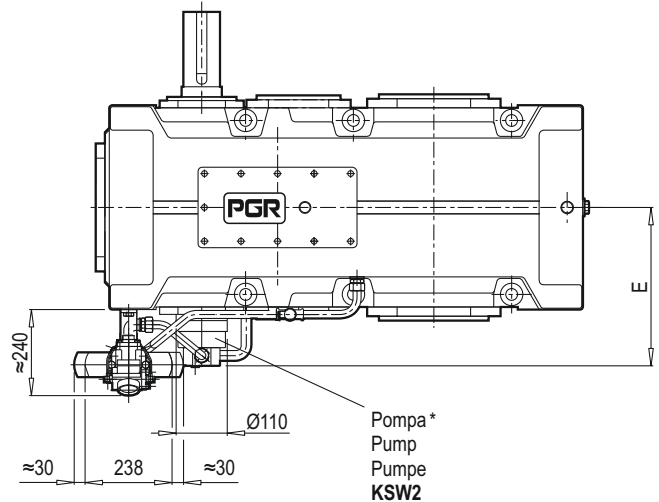
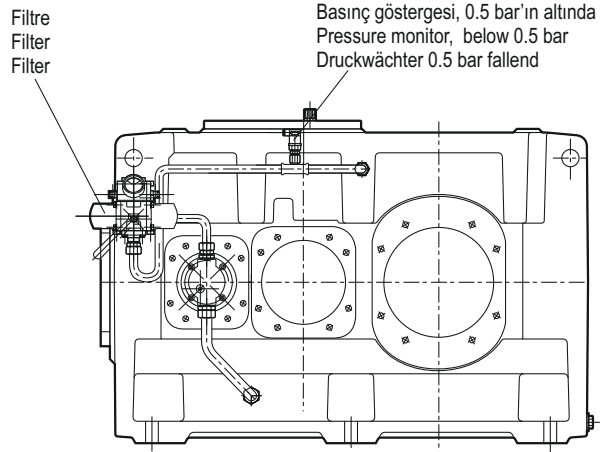

Zemin düz ve yatay olmalıdır.
Talep edildiğinde eğik pozisyon.

The foundation must be flat and horizontal.
Inclined position on request.

Fundament muss waagrecht und eben
sein, Schräglage auf Anfrage.

Tablo 10 / Table 10 / Tabelle 10

Redüktör boyutu Gear unit size Getriebegröße	52	62	72	82	92	102	112	122	132	142	152	162	172	182
E mm	270	290	290	315	315	315	350	350	445	445	480	480	505	505

*) Aşağıdaki hızlar için geçerlidir:
n1 ≥ 900' den 1800 d/d'ya kadar

*) Applies to speeds:
n1 ≥ 1500 up to 1800 min⁻¹

*) Gültig für Drehzahlen:
n1 ≥ 1500 bis 1800 min⁻¹

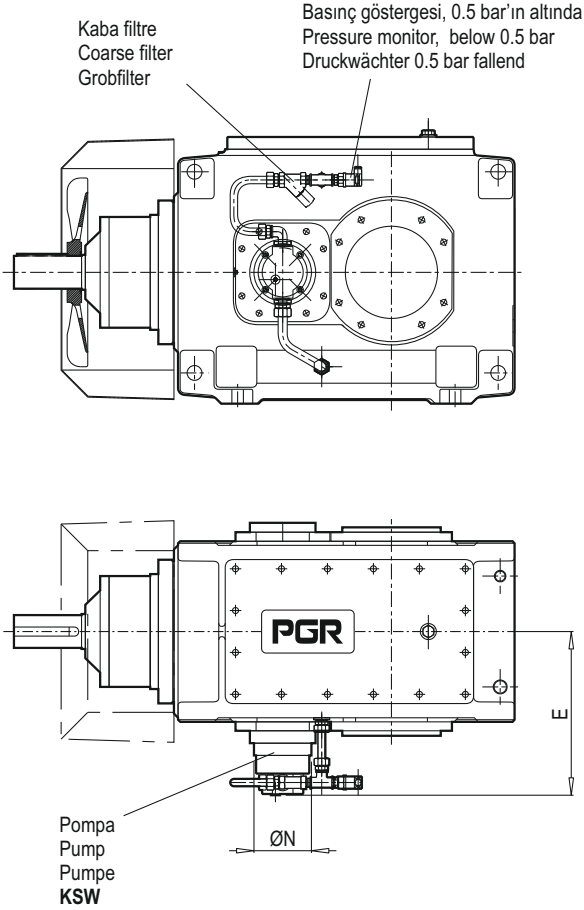
Gövdeler / Sizes / Größen
52 - 122

Zemin düz ve yatay olmalıdır.
Talep edildiğinde eğik pozisyon

The foundation must be flat and horizontal.
Inclined position on request.

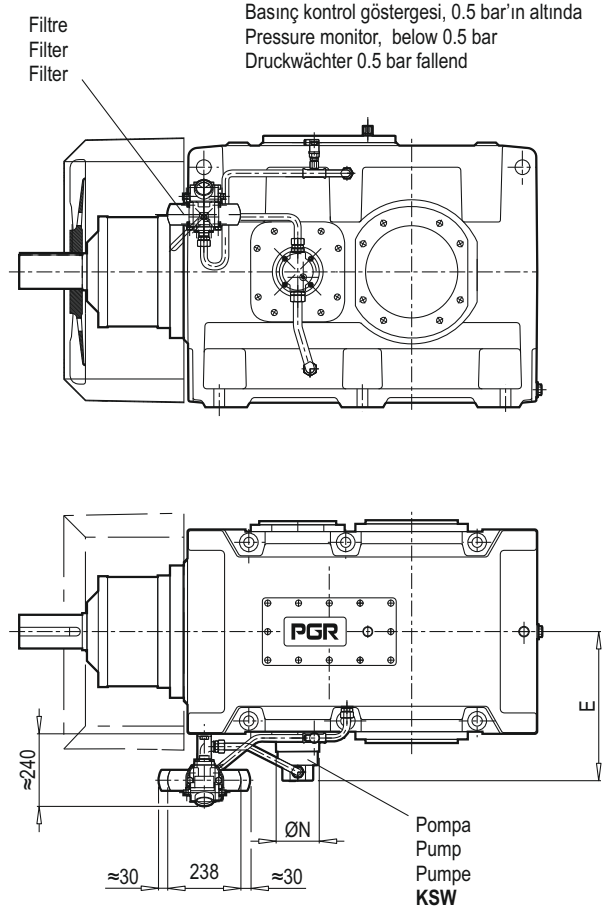
Gövdeler / Sizes / Größen
132 - 182

Fundament muss waagrecht und eben sein,
Schräglage auf Anfrage.

Tablo 11 / Table 11 / Tabelle 11

Redüktör boyutu Gear unit size Getriebegröße	52 / 62			72 / 82			92 / 102			112 / 122			132 / 142		152 / 162		172 / 182	
Pompa* Pump / Pumpe KSW	1	2	3	1	2	3	1	2	3	1	2	3	2	3	2	3	2	3
ØN	110	110	140	110	110	140	110	110	140	110	110	140	110	140	110	140	110	140
E	345	345	345	375	375	375	405	405	405	445	445	445	495	495	550	550	610	610

*) Aşağıdaki hızlar için geçerlidir:
1 ve 2 Boyutu $n_1 \geq 1500$ 'den 1800 d/d'ya
3 Boyutlu $n_1 \geq 1200$ ' den 1800 d/d ya kadar

*) Applies to the following speeds:
Sizes 1 and 2 $n_1 \geq 1500$ up to 1800 min⁻¹
Size 3 $n_1 \geq 1200$ up to 1800 min⁻¹

*) Gültig für Folgende Drehzahlen:
Größen 1 und 2 $n_1 \geq 1500$ bis 1800 min⁻¹
Größe 3 $n_1 \geq 1200$ bis 1800 min⁻¹

TR SULU YAĞ SOĞUTUCUSU - YATAY

EN WATER - OIL COOLER - HORIZONTAL

DE WASSER - ÖLKÜHLER - HORIZONTAL

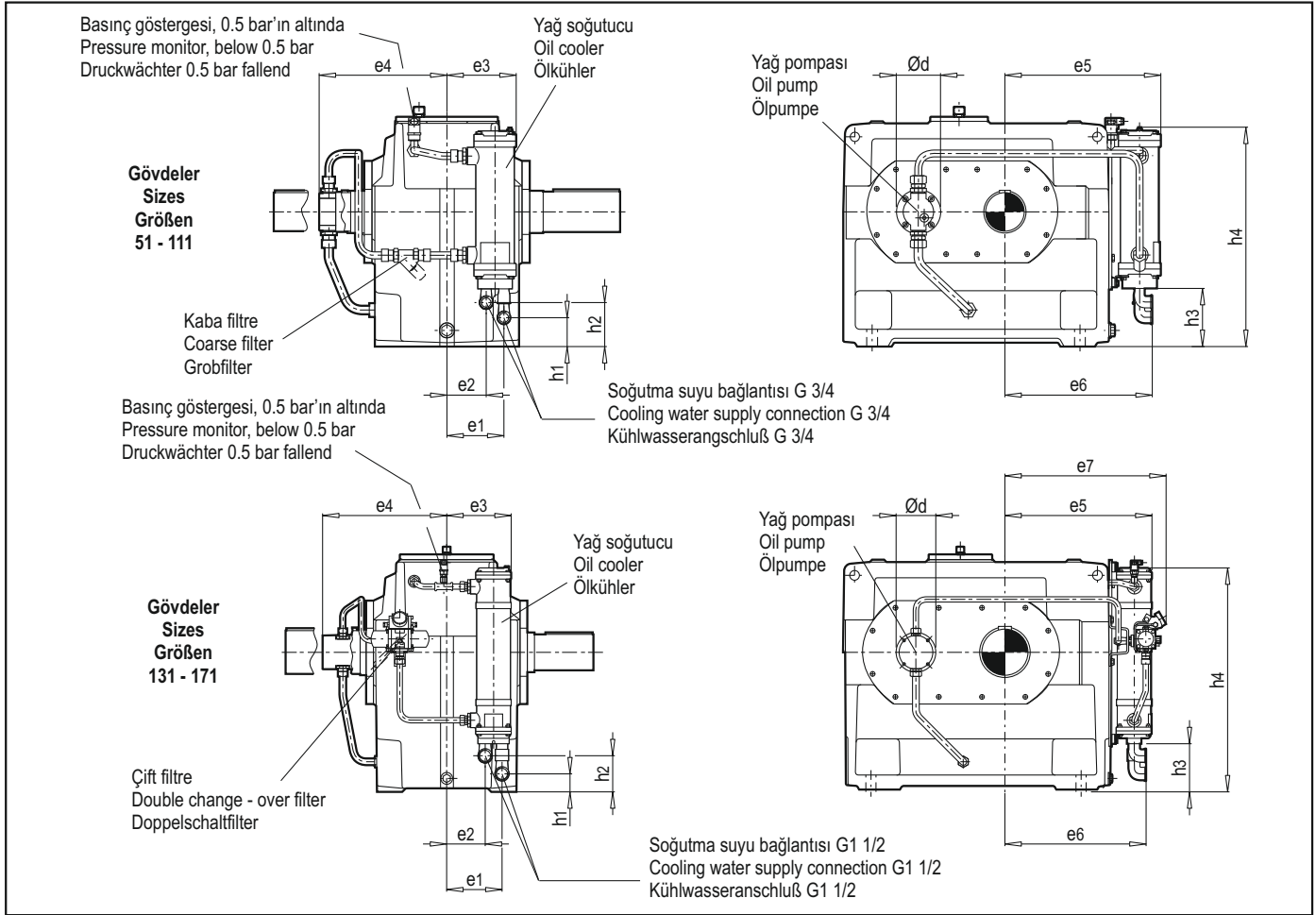

Tablo 12 / Table 12 / Tabelle 12

Redüktör boyutu Gear unit size Getriebe-größe	Yağ soğutucu / Oil cooler / Ölkühler												Yağ Pompası * Oil pump / Ölpumpe		
	Boyut Size Größe	e1	e2	e3	e4	e5	e6	e7	h1	h2	h3	h4	KSW Boyut / Size Größe	Ød mm	Tahvil / Ratio Übersetzung İges
51	01	138	92	170	283	370	347	-	55	95	130	550	1	110	1.25 ... 5.6
71	01	148	102	180	336	410	388	-	90	130	165	570	2	110	1.25 ... 4
					321								1	110	4.5 ... 5.6
91	01	160	114	195	374	455	433	-	140	180	215	620	2	110	1.25 ... 2.8
					374								2	110	3.15 ... 4
					359								1	110	4.5 ... 5.6
111	01	193	147	225	434	515	493	-	185	225	260	665	3	140	1.6 ... 2.8
					434								3	140	3.15 ... 4
					407								2	110	4.5 ... 5.6
131	03	230	160	270	470	615	593	675	75	150	200	938	3	140	1.6 ... 2.8
					470								3	140	3.15 ... 4
					443								2	110	4.5 ... 5.6
151	03	210	140	250	473	690	669	750	95	170	220	958	3	140	2 ... 2.8
					475								3	140	3.15 ... 4
					448								2	110	4.5 ... 5.6
171	03	235	165	275	492	730	709	790	155	230	280	1018	3	140	2 ... 2.8
					492								3	140	3.15 ... 4
					456								2	110	4.5 ... 5.6

Thermal kapasitenin, Pt4 sınırlarının aşması durumunda, yağ soğutucu veya yağ pompası kullanılmalıdır. (Tercihen fan ile birlikte kullanın)

Dikey redüktörler, talep edildiğinde temin edilir.

Thermal kapasite sınır değerleri, talep edildiğinde temin edilir. Soğutucu tatlı su ve deniz suyu için uygundur.

*) n1 = 900 - 1800 d/d arasında

If the thermal capacities Pt4 are exceeded, oil cooler and oil pump have to be provided, possibly together with a fan.

Vertical gear units on request.

Thermal capacities on request.

Cooler suitable for fresh and sea water

*) Applies to speeds n1 = 900 - 1800 min⁻¹

Beim Überschreiten der Wärmegrenzleistungen Pt4 sind Ölkühler und Ölpumpe vorzusehen, (evtl. zusammen mit Lüfterbetrieb).

Vertikalgetriebe auf Anfrage

Wärmegrenzleistungen auf Anfrage

Kühler geeignet für Süß- und Seewasser

*) Gültig für Drehzahlen n1 = 900 - 1800 min⁻¹

TR SULU - YAĞ SOĞUTUCUSU - YATAY

EN WATER-OIL COOLER - HORIZONTAL

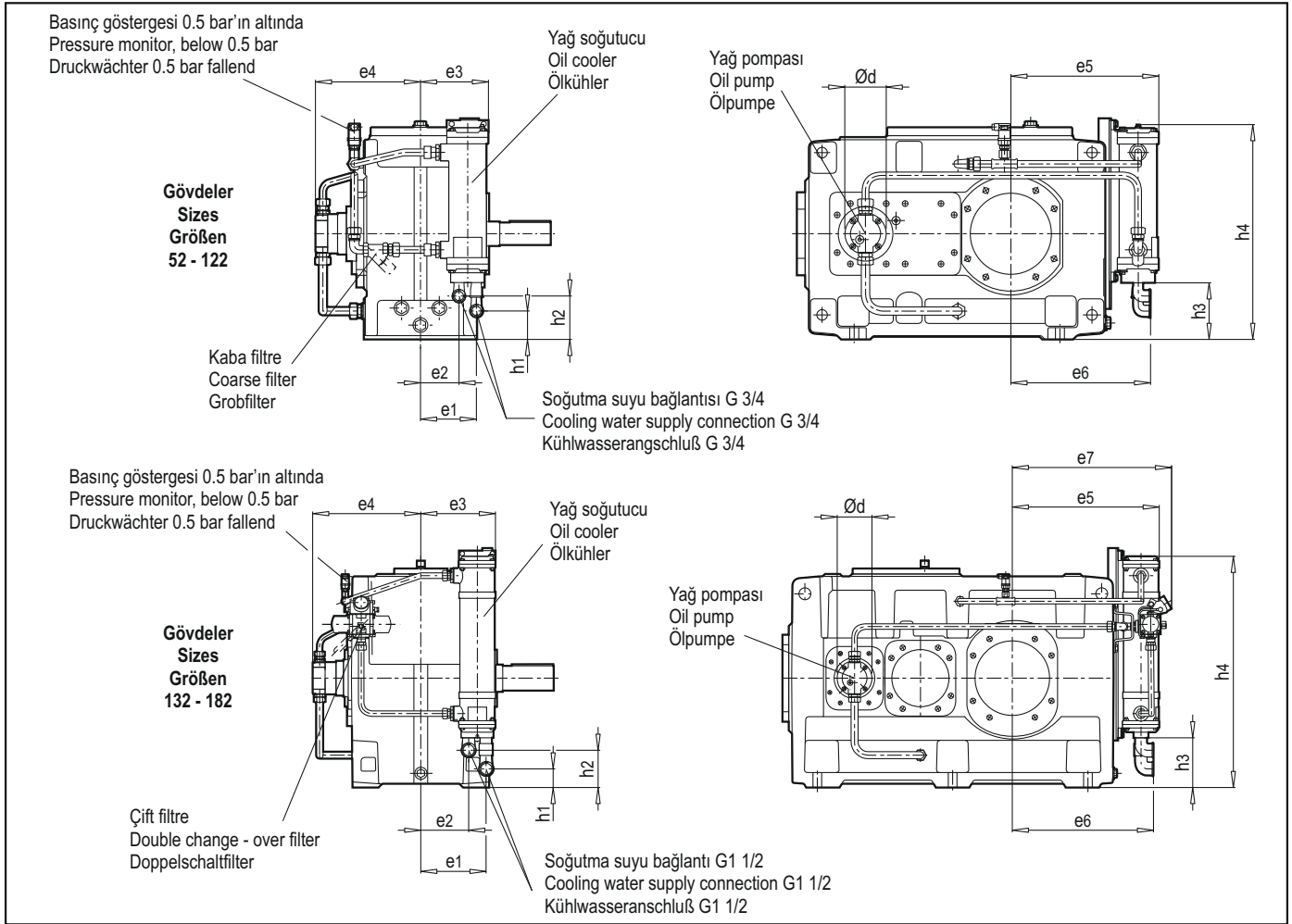
DE WASSER - ÖLKÜHLER - HORIZONTAL

Tablo 13 / Table 13 / Tabelle 13

Redüktör gövdesi Gear unit size Getriebe-größe	Yağ soğutucu / Oil cooler / Ölkühler												Yağ Pompası * Oil pump / Ölpumpe	
	Gövde Size Größe	e1	e2	e3	e4	e5	e6	e7	h1	h2	h3	h4	KSW Gövde Size/Größe	Ød mm
52	01	123	77	155	264	355	323	-	55	95	130	550	1	110
62		123	77	155	264	400	368	-	55	95	130	550		
72		148	102	180	284	400	368	-	75	115	150	570		
82	01	148	102	180	284	460	428	-	75	115	150	570	1	110
92		173	127	205	307	460	418	-	150	190	225	645		
102		173	127	205	307	500	468	-	150	190	225	645		
112	01	203	157	235	343	500	463	-	225	265	300	720	1	110
122	01	203	157	235	343	585	548	-	225	265	300	720	2	
132	03	260	190	300	411	595	568	650	75	150	200	938	2	
142	03	260	190	300	411	675	638	730	75	150	200	938	2	110
152		300	230	340	446	675	648	730	105	180	230	968		
162		300	230	340	446	720	693	775	105	180	230	968		
172	03	330	260	370	476	720	688	775	145	220	270	1008	2	110
182						775	748	830						

 *) Tüm tahvil oranları için
(n1 = 750 - 1800 d/d)

Termal kapasitenin Pt4 sınırlarının aşması durumunda, yağ soğutucu veya yağ pompası kullanılmalıdır. (Tercih fan ile birlikte kullanılır).

Dikey redüktörler için, talep edildiğinde temin edilir.

Termal kapasite sınır değerleri, talep edildiğinde temin edilir. Soğutucu, tatlı su ve deniz suyu için uygundur.

 *) For all transmission ratios
(n1 = 750 - 1800 min⁻¹)

If the thermal capacities Pt4 are exceeded, oil cooler and oil pump have to be provided, possibly together with a fan.

Vertical gear units on request

Thermal capacities on request

Cooler suitable for fresh and sea water

 *) Für alle Übersetzungen
(n1 = 750 - 1800 min⁻¹)

Beim Überschreiten der Wärmegrenzleistungen Pt4 sind Ölkühler und Ölpumpe vorzusehen, (evtl. zusammen mit Lüfterbetrieb).

Vertikalgetriebe auf Anfrage

Wärmegrenzleistungen auf Anfrage

Kühler geeignet für Süß- und Seewasser

TR SULU - YAĞ SOĞUTUCUSU - YATAY

EN WATER - OIL COOLER - HORIZONTAL

DE WASSER - ÖLKÜHLER - HORIZONTAL

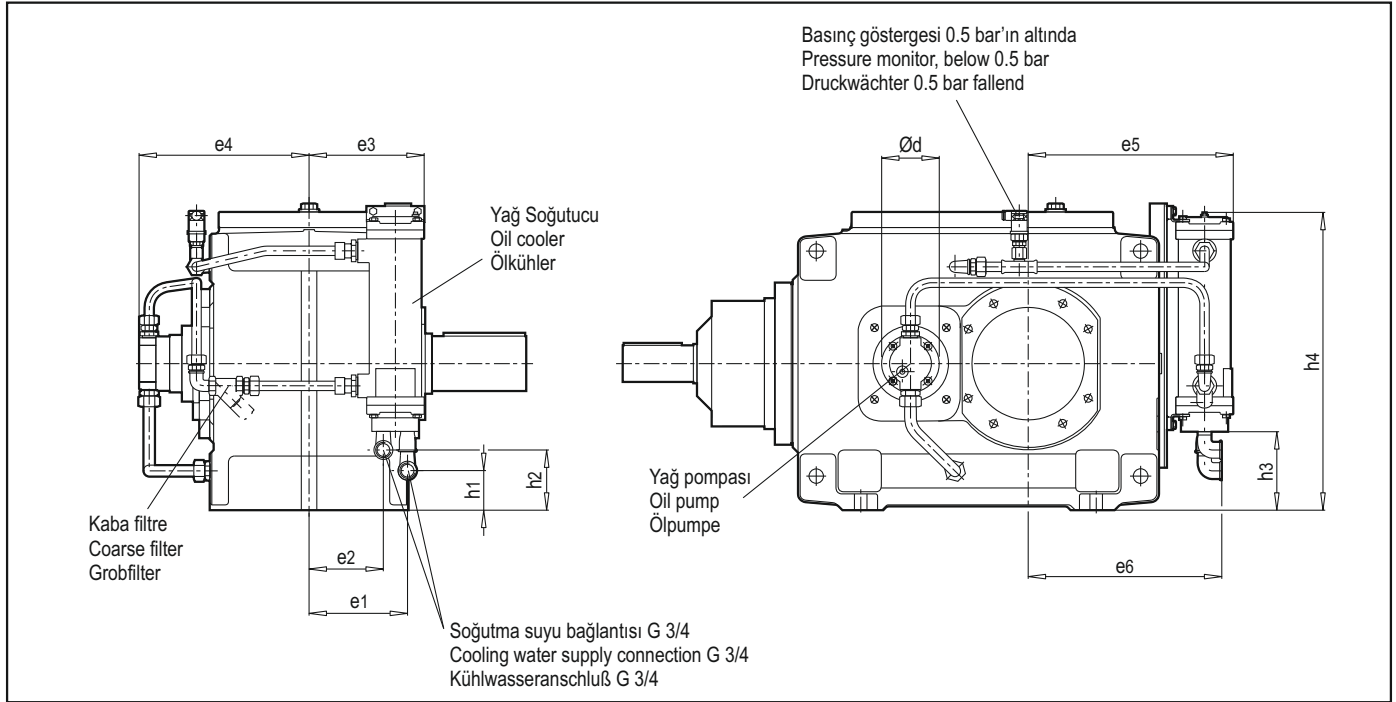

Tablo 14 / Table 14 / Tabelle 14

Redüktör Gövdesi Gear unit size Getriebegröße	Yağ soğutucu / Oil cooler / Ölkühler											Yağ Pompası Oil pump / Ölpumpe *	
	Boyut Size Größe	e1	e2	e3	e4	e5	e6	h1	h2	h2	h4	KSW Boyut /Size Größe	Ød mm
52	01	158	112	190	341	360	328	55	95	130	550	3	140
					314							2	110
					299							1	110
62	01	158	112	190	341	405	373	55	95	130	550	3	140
					314							2	110
					299							1	110
72	01	188	142	220	371	405	373	75	115	150	570	3	140
					344							2	110
					329							1	110
82	01	188	142	220	371	465	433	75	115	150	570	3	140
					344							2	110
					329							1	110
92	01	218	172	250	400	465	423	150	190	225	645	3	140
					373							2	110
					358							1	110
102	01	218	172	250	400	505	473	150	190	225	645	3	140
					373							2	110
					358							1	110
112	01	263	217	295	441	505	468	225	265	300	720	3	140
					414							2	110
					399							1	110
122	01	263	217	295	441	585	553	225	265	300	720	3	140
					414							2	110
					399							1	110

Termal kapasitenin Pt4 sınırlarının aşması durumunda, yağ soğutucu veya yağ pompası kullanılmalıdır (Tercih fan ile birlikte kullanın).

Dikey redüktörler, talep edildiğinde temin edilir.

Termal kapasite sınır değerleri, talep edildiğinde temin edilir.

If the thermal capacities Pt4 are exceeded, oil cooler and oil pump have to be provided, possibly together with a fan.

Vertical gear units on request

Thermal capacities on request

Cooler suitable for fresh and sea water

Beim Überschreiten der Wärmegrenzleistungen Pt4 sind Ölkühler und Ölpumpe vorzusehen, (evtl. zusammen mit Lüfterbetrieb).

Vertikalgetriebe auf Anfrage

Wärmegrenzleistungen auf Anfrage

Geeignet für Süß- und Seewasser

*) Soğutucu, tatlı su ve deniz suyu için uygundur. Farklı pompa büyüklükleri için, dikey redüktörler belirtilen çevrim oranları ve n₁ devir sayıları için geçerlidir. Sayfa 141'e bakınız.

*) For different pump sizes the transmission ratio assignments will apply as determined for vertical gear units and speeds n₁, see page 141.

*) Bei unterschiedlichen Pumpengrößen gelten die für Vertikalgetriebe festgelegten Übersetzungszuordnungen und Drehzahlen n₁, siehe Seite 141.

TR SULU - YAĞ SOĞUTUCUSU - YATAY

EN WATER - OIL COOLER - HORIZONTAL

DE WASSER - ÖLKÜHLER - HORIZONTAL

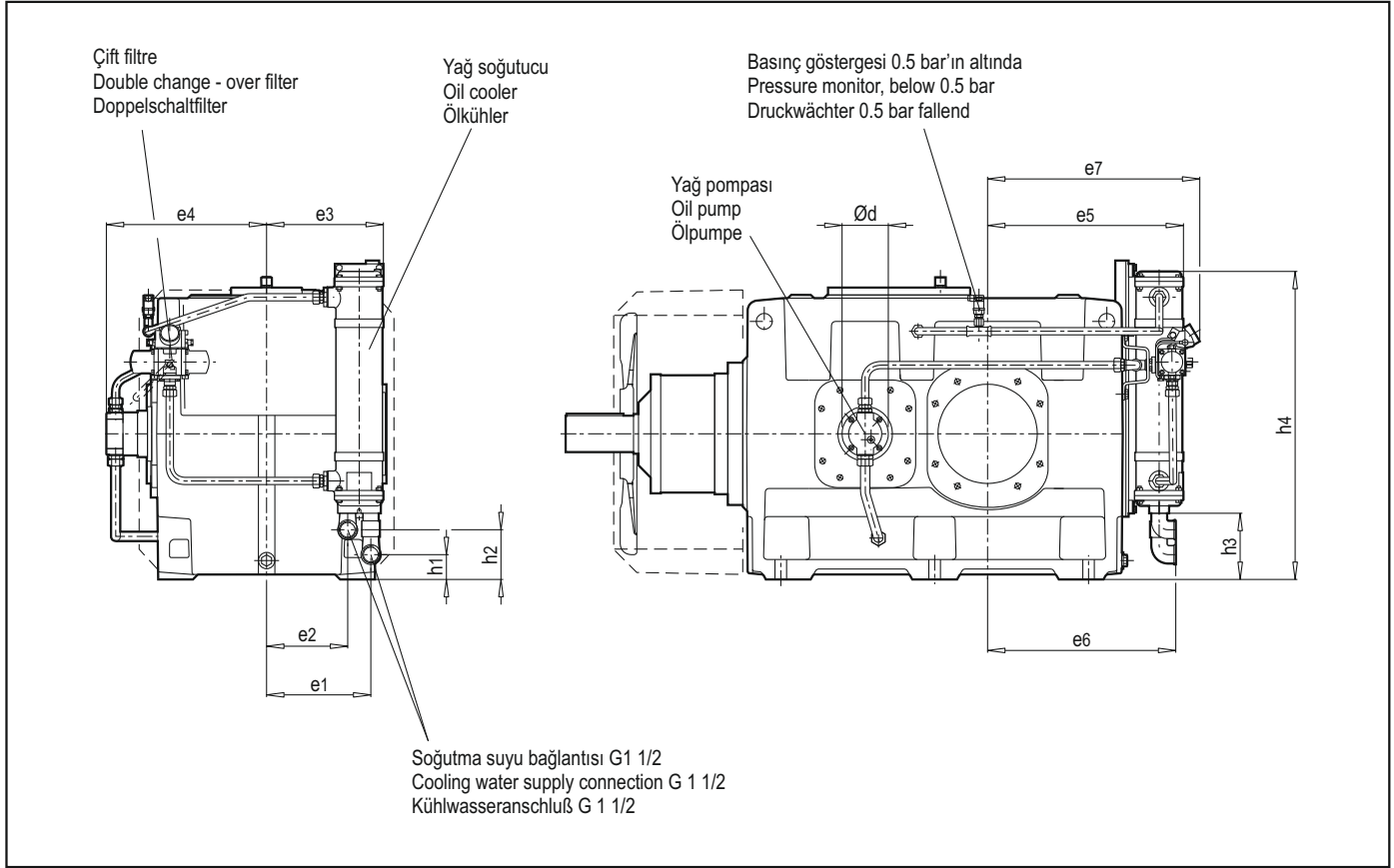

Tablo 15 / Table 15 / Tabelle 15

Redüktör boyutu Gear unit size Getriebegröße	Yağ soğutucu / Oil cooler / Ölkühler												Yağ Pompası * Oil pump / Ölpumpe	
	Boyut Size Größe	e1	e2	e3	e4	e5	e6	e7	h1	h2	h3	h4	KSW Boyut/Size Größe	Ød mm
132	03	320	250	355	488 461	600	578	650	75	150	200	938	3 2	140 110
142	03	320	250	355	488 461	670	648	720	75	150	200	938	3 2	140 110
152	03	375	305	410	544 517	680	658	730	105	180	230	968	3 2	140 110
162	03	375	305	410	544 517	725	703	775	105	180	230	968	3 2	140 110
172	03	435	365	470	606 579	725	698	775	145	220	270	1008	3 2	140 110
182	03	435	365	470	606 579	780	758	830	145	220	270	1008	3 2	140 110

Termal kapasitenin Pt4 sınırlarının aşması durumunda, yağ soğutucu veya yağ pompası kullanılmalıdır (Tercih fan ile birlikte kullanın).

Dikey redüktörler için, talep edildiğinde temin edilir.
Termal kapasite sınır değerleri, talep edildiğinde temin edilir.

If the thermal capacities Pt4 are exceeded, oil cooler and oil pump have to be provided, possibly together with a fan.

Vertical gear units on request
Thermal capacities on request
Cooler suitable for fresh and sea water

Beim Überschreiten der Wärmegrenzleistungen Pt4 sind Ölkühler und Ölpumpe vorzusehen (evtl. zusammen mit Lüfterbetrieb).

Vertikalgetriebe auf Anfrage
Wärmegrenzleistungen auf Anfrage
Geeignet für Süß- und Seewasser

*) Soğutucu, tatlı su ve deniz suyu için uygundur. Farklı pompa büyüklükleri için, dikey redüktörler belirtilen çevrim oranları ve n₁ devir sayıları için geçerlidir. Sayfa 141'e bakınız.

*) For different pump sizes the transmission ratio assignments will apply as determined for vertical gear units and speeds n₁, see page 141.

*) Bei unterschiedlichen Pumpengrößen gelten die für Vertikalgetriebe festgelegten Übersetzungszuordnungen und Drehzahlen n₁, siehe Seite 141.

TR HAVALI - YAĞ SOĞUTUCUSU - YATAY

EN AIR - OIL COOLER - HORIZONTAL

DE LUFT - ÖLKÜHLER - HORIZONTAL

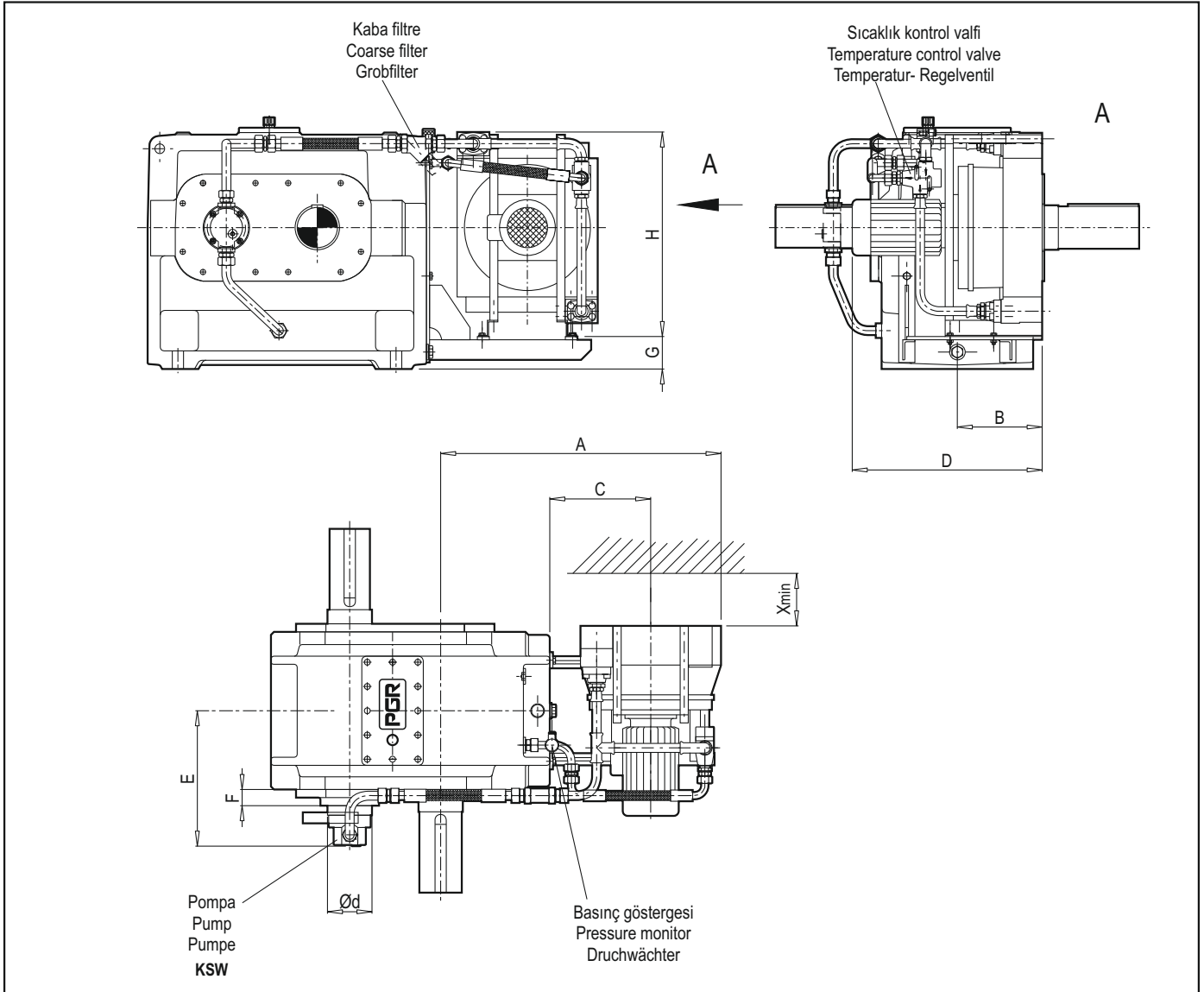

Tablo 16 / Table 16 / Tabelle 16

Redüktör boyutu Gear unit size Getriebegröße	A	B	C	D	E	F	G	H	Xmin	Boyut / Size / Größe		
										Pompa / Pump / Pumpe *		
										KSW	Ød	Tahvil / Ratio Übersetzung İges
51	655	240	250	470	282	46.5	75	440	130	1	110	1.25 ... 5.6
71	695	210	250	470	335	40	80	510		2	110	1.25 ... 4
					1					110	4.5 ... 5.6	
91	865	240	320	540	373	50	100	615		2	110	1.25 ... 2.8
					2					110	3.15 ... 4	
					1					110	4.5 ... 5.6	
111	925	240	320	540	433	38	130	715		3	140	1.6 ... 2.8
					3					140	3.15 ... 4	
					2					110	4.5 ... 5.6	

*) Tüm tahvil oranları için;
n1 = 900 - 1800 d/d
Dikey redüktörler için, talep edildiğinde temin edilir.
Thermal kapasite sınır değerleri, talep edildiğinde temin edilir.

*) Applies to speeds n1 = 900 - 1800 min⁻¹
Vertical gear units on request
Thermal capacities on request

*) Gültig für drehzahlen n1 = 900 - 1800 min⁻¹
Vertikalgetriebe auf Anfrage
Wärmegrenzleistungen auf Anfrage

TR HAVALI - YAĞ SOĞUTUCUSU - YATAY

EN AIR-OIL COOLER - HORIZONTAL

DE LUFT - ÖLKÜHLER - HORIZONTAL

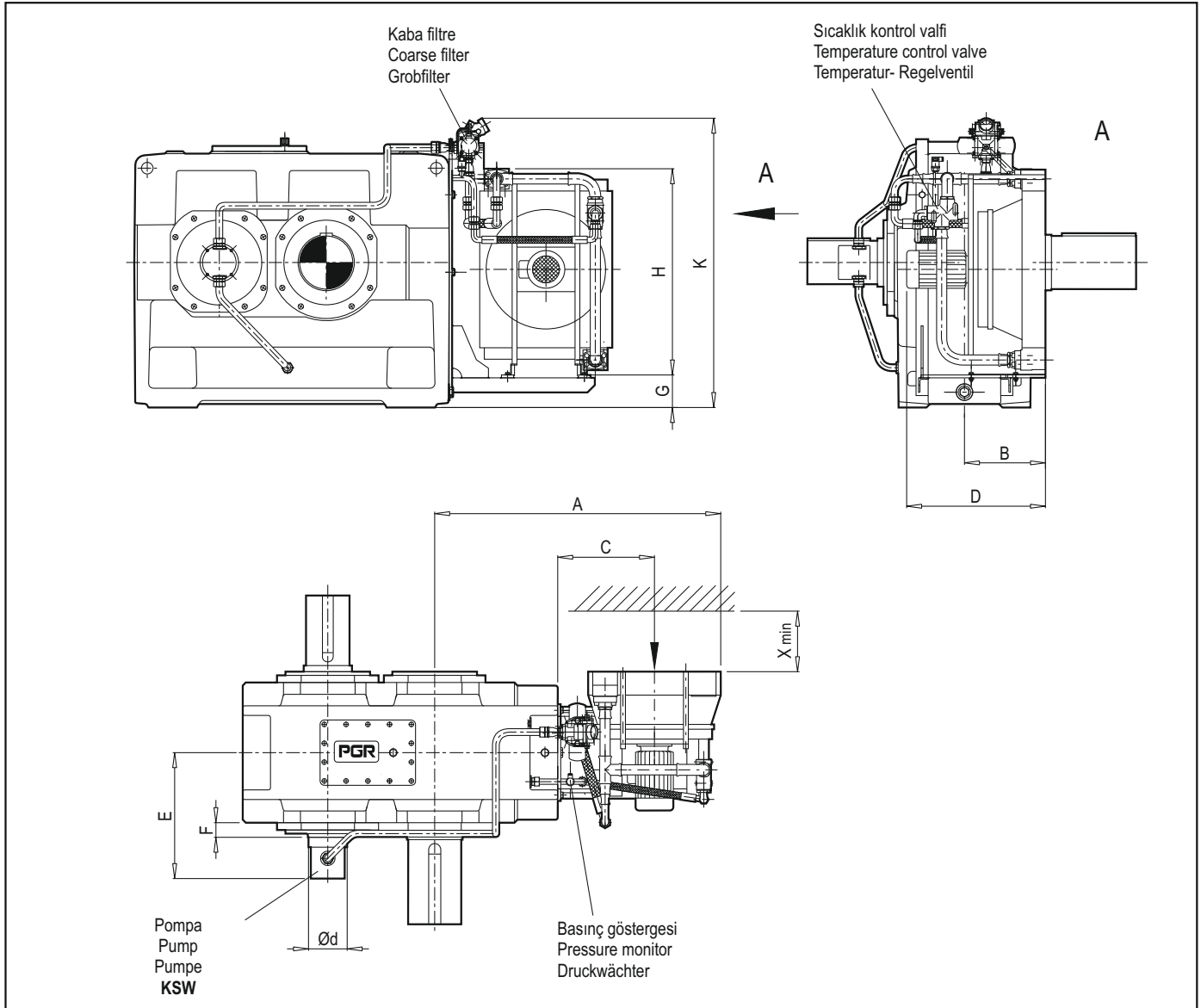

Tablo 17 / Table 17 / Tabelle 17

Redüktör boyutu Gear unit size Getriebegröße	A	B	C	D	E	F	G	H	K	Xmin	Gövde / Size / Größe		
											Pompa / Pump / Pumpe *		
											KSW	Ød	Tahvil / Ratio Übersetzung İges
131	1115	350	400	580	469	40	115	725	1100	130	3	140	1.6 ... 2.8
					469						3	140	3.15 ... 4
					442						2	110	4.5 ... 5.6
151	1200	355	400	580	474	60	135	855	1190	250	3	140	2 ... 2.8
					474						3	140	3.15 ... 4
					447						2	110	4.15 ... 5.6
171	1380	357	480	640	491	42	235	855	1310	350	3	140	2 ... 2.8
					491						3	140	3.15 ... 4
					455						2	110	4.5 ... 5.6

*) Tüm tahvil oranlar için
 $n_1 = 900 - 1800 \text{ d/d}$
 Dikey redüktörler, talep edildiğinde temin edilir.
 Thermal kapasite sınır değerleri, talep edildiğinde temin edilir.

*) Applies to speeds
 $n_1 = 900 - 1800 \text{ min}^{-1}$
 Vertical gear units on request
 Thermal capacities on request

*) Gültig für Drehzahlen
 $n_1 = 900 - 1800 \text{ min}^{-1}$
 Vertikalgetriebe auf Anfrage
 Wärmegrenzleistungen auf Anfrage

TR HAVALI - YAĞ SOĞUTUCUSU - YATAY

EN AIR - OIL COOLER - HORIZONTAL

DE LUFT - ÖLKÜHLER - HORIZONTAL

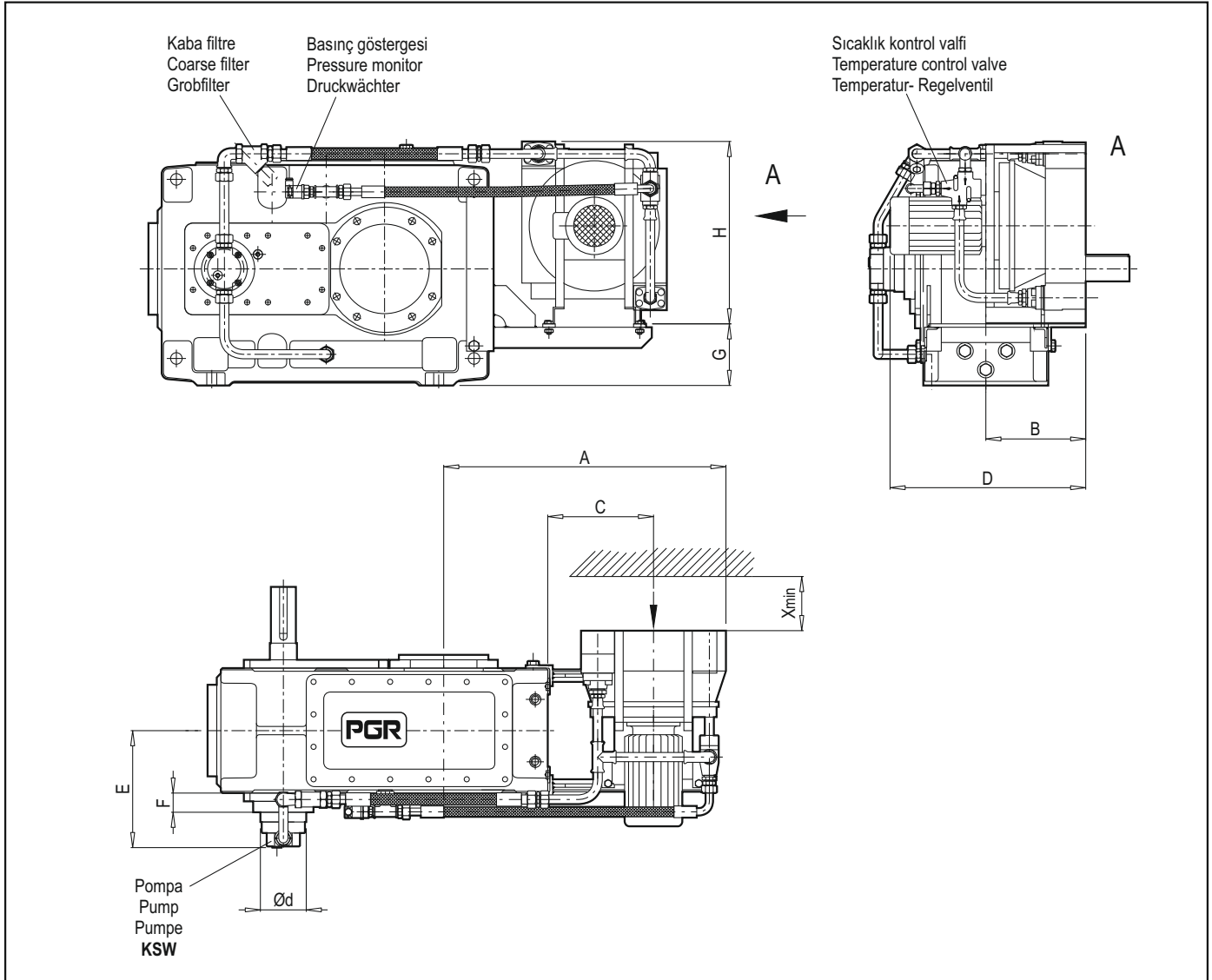

Tablo 18 / Table 18 / Tabelle 18

Redüktör boyutu Gear unit size Getriebegröße	A	B	C	D	E	F	G	H	Xmin	Gövde / Size / Größe	
										Pompa / Pump Pumpe *	
										KSW	Ød
52	580	250	225	425	263	50	125	380	130	1	110
62	625	250	225	525	263	50	125	380		1	
72	680	240	255	470	283	48	150	440		1	
82	740	240	255	470	283	48	150	440		1	
92	730	230	255	470	306	36	150	510		1	
102	780	230	255	470	306	36	150	510		1	
112	880	260	310	540	342	42	190	615		1	
122	965	260	310	540	342	42	190	615		1	

*) Tüm tahvil oranları için;
(n1 = 750 - 1800 d/d)
Dikey redüktörler, talep edildiğinde temin edilir.
Termal kapasite sınır değerleri, talep edildiğinde temin edilir.

*) For all transmission ratios
(n1 = 750 - 1800 min⁻¹)
Vertical gear units on request
Thermal capacities on request

*) Für alle Übersetzungen
(n1 = 750 - 1800 min⁻¹)
Vertikalgetriebe auf Anfrage
Wärmegrenzleistungen auf Anfrage

TR HAVALI - YAĞ SOĞUTUCUSU - YATAY

EN AIR- OIL COOLER - HORIZONTAL

DE LUFT - ÖLKÜHLER - HORIZONTAL

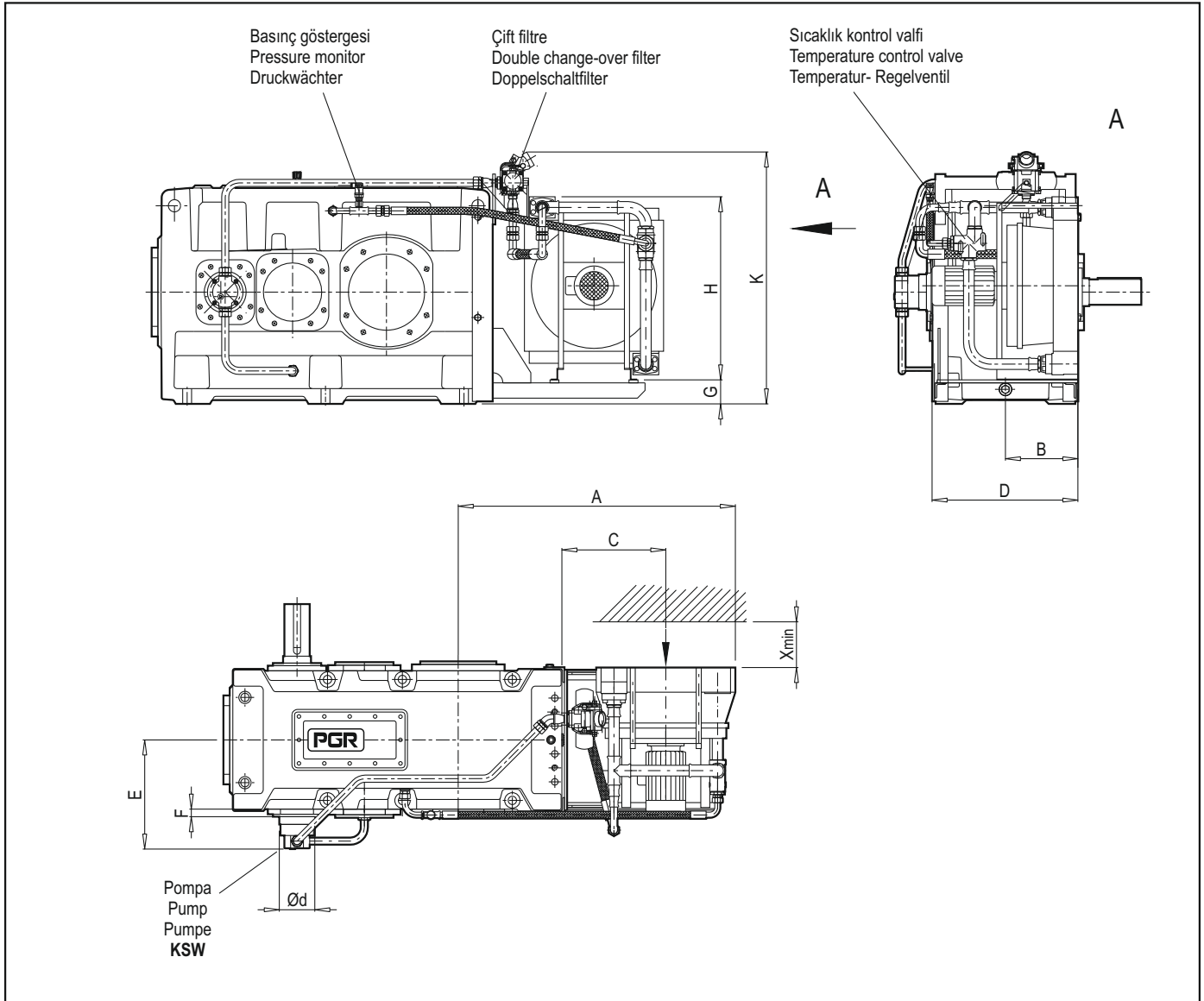

Tablo 19 / Table 19 / Tabelle 19

Redüktör boyutu Gear unit size Getriebegröße	A	B	C	D	E	F	G	H	K	Xmin	Boyut / Size / Größe	
											Pompa / Pump Pumpe *	
											KSW	Ød
132	1000	270	365	540	410	37	95	715	990	130	2	110
142	1070	270	365	540	410	37	95	715	990	130		
152	1175	290	410	574	445	35	150	725	1090	130		
162	1220	290	410	574	445	35	150	725	1090	130		
172	1215	290	410	574	475	35	170	860	1195	250		
182	1275	290	410	574	475	35	170	860	1195	250		

*) Tüm tahvil oranları için;
(n1 = 750 - 1800 d/d)
Dikey redüktörler, talep edildiğinde temin edilir.
Thermal kapasite sınır değerleri, talep edildiğinde temin edilir.

*) For all transmission ratios
(n1 = 750 - 1800 min⁻¹)
Vertical gear units on request
Thermal capacities on request

*) Für alle Übersetzungen
(n1 = 750 - 1800 min⁻¹)
Vertikalgetriebe auf Anfrage
Wärmegrenzleistungen auf Anfrage

TR HAVALI - YAĞ SOĞUTUCUSU - YATAY

EN AIR - OIL COOLER - HORIZONTAL

DE LUFT - ÖLKÜHLER - HORIZONTAL

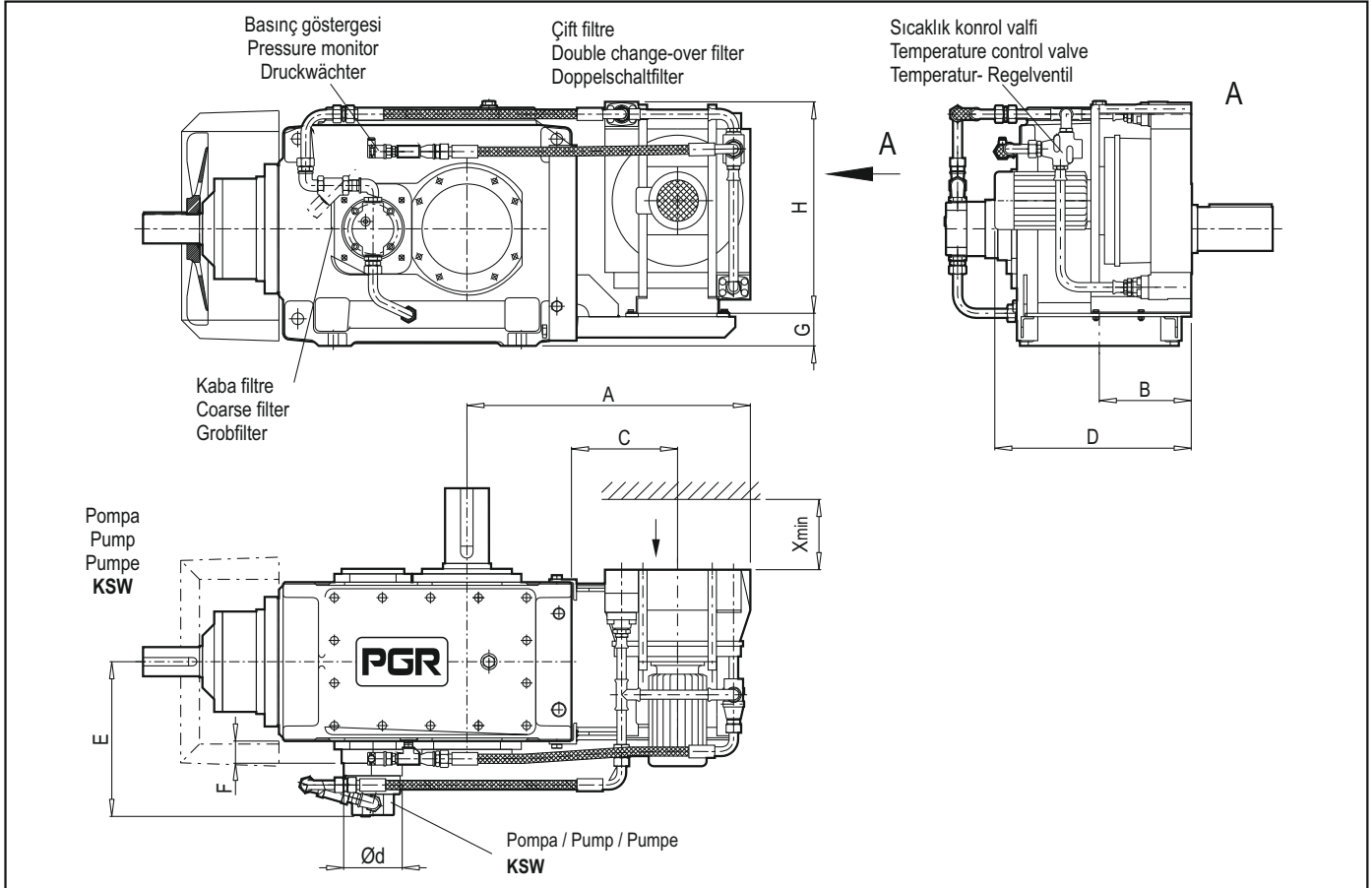

Tablo 20 / Table 20 / Tabelle 20

Redüktör boyutu Gear unit size Getriebegröße	A	B	C	D	E	F	G	H	Xmin	Gövde / Size / Größe		
										Pompa / Pump Pumpe *		
										KSW	Ød	
	mm											
52	634	190	255	470	340 313 298	53		440		3 2 1	140 110 110	
62	679	190	255	470	340 313 298	53		440		3 2 1	140 110 110	
72	679	220	255	470	370 343 328	53		510		3 2 1	140 110 110	
82	739	220	255	470	370 343 328	53	80	510	130	3 2 1	140 110 110	
92	887	220	310	540	399 372 357	52		615		3 2 1	140 110 110	
102	937	220	310	540	399 372 357	52		615		3 2 1	140 110 110	
112	882	220	310	540	440 413 398	48		715		3 2 1	140 110 110	
122	967	220	310	540	440 413 398	48		715		3 2 1	140 110 110	

Dikey redüktörler, talep edildiğinde temin edilir.
Thermal kapasite sınır değerleri, talep edildiğinde temin edilir.
*) Farklı pompa büyüklükleri için belirtilen çevrim oranları ve n1 devir sayıları geçerlidir. Sayfa 141'e bakınız.

Vertical gear units on request
Thermal capacities on request
*) For different pump sizes the transmission ratio assignments will apply as determined
For vertical gear units and speeds n1, see page 141.

Vertikalgetriebe auf Anfrage
Wärmegrenzleistungen auf Anfrage
*) Bei unterschiedlichen Pumpengrößen gelten die für Vertikalgetriebe festgelegten Übersetzungsanordnungen und Drehzahlen n1, siehe Seite 141.

TR HAVALI - YAĞ SOĞUTUCUSU - YATAY

EN AIR- OIL COOLER - HORIZONTAL

DE LUFT - ÖLKÜHLER - HORIZONTAL

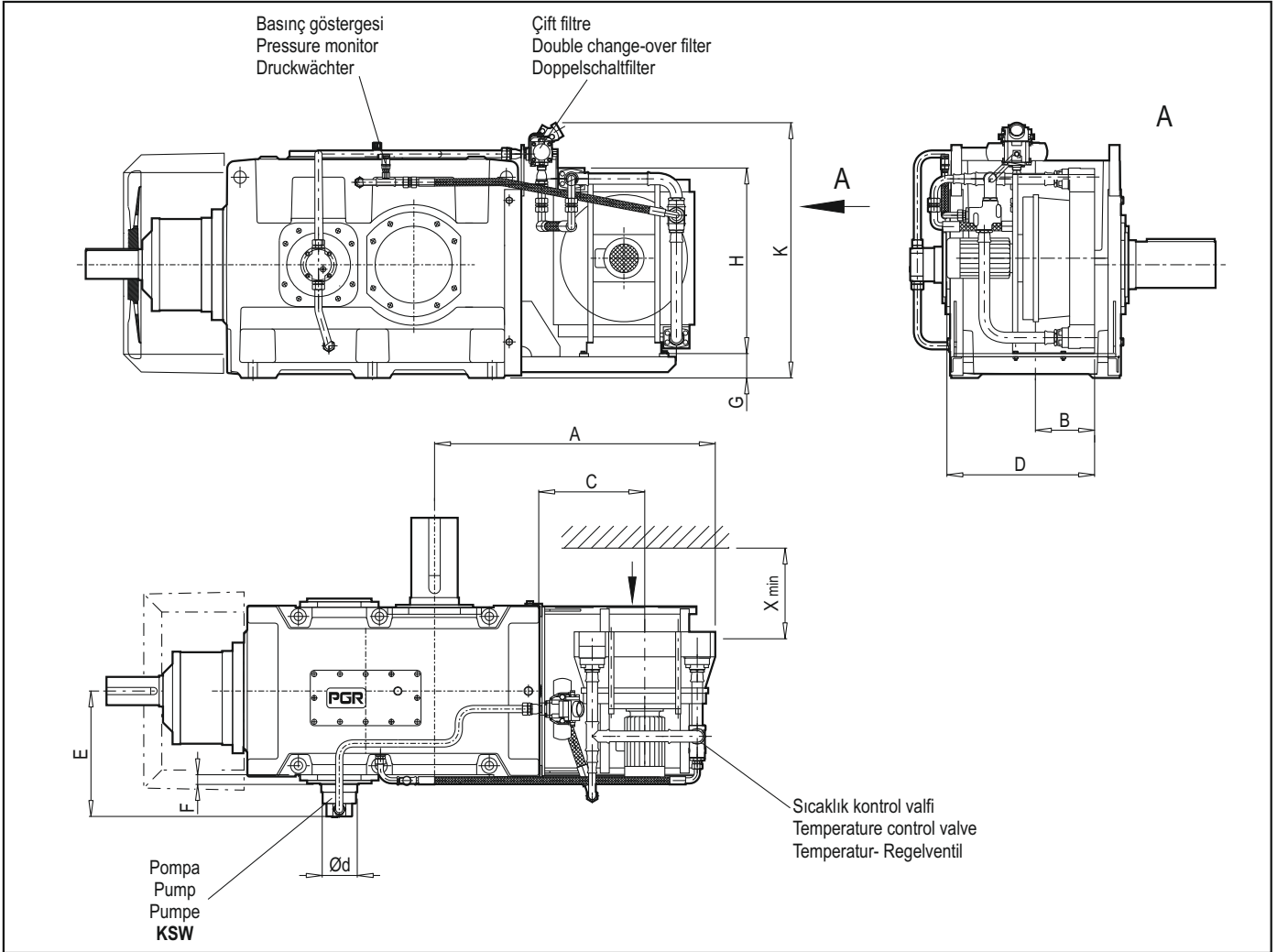

Tablo 21 / Table 21 / Tabelle 21

Redüktör Boyutu Gear unit size Getriebegröße	A	B	C	D	E	F	G	H	K	X _{min}	Gövde / Size / Größe	
											Pompa / Pump Pumpe *	
											KSW	Ød
132	1092	230	410	574	487 460	35	95	725	995	130	3	140
											2	110
142	1162	230	410	574	487 460	35	95	725	995	130	3	140
											2	110
152	1172	175	410	574	543 516	36	95	860	1095	250	3	140
											2	110
162	1217	175	410	574	543 516	36	95	860	1095	250	3	140
											2	110
172	1337	150	480	635	605 578	40	113.5	860	1200	350	3	140
											2	110
182	1397	150	480	635	605 578	40	113.5	860	1200	350	3	140
											2	110

Dikey redüktörler, talep edildiğinde temin edilir.
 Termal kapasite sınır değerleri, talep edildiğinde temin edilir.
 *) Farklı pompa büyüklükleri için belirtilen çevrim oranları ve n1 devir sayıları geçerlidir. Sayfa 141'e bakınız.

Vertical gear units on request
 Thermal capacities on request
 *) For different pump sizes the transmission ratio assignments will apply as determined
 For vertical gear units and speeds n1 see page 141.

Vertikalgetriebe auf Anfrage
 Wärmegrenzleistungen auf Anfrage
 *) Bei unterschiedlichen Pumpengrößen gelten die für Vertikalgetriebe festgelegten Übersetzungsanordnungen und Drehzahlen n1, siehe Seite 141.

Redüktör boyutu Gear unit size Getriebegröße	PH/PB4... - PH/PB12...	PH/PB13... - PH/PB18...
Yatay montaj pozisyonu Horizontal mounting position Horizontale Einbaulage		
Şaft montajlı Dizayn Shaft - mounted design Aufsteckausführung		
Dikey montaj pozisyonu Vertical mounting position Vertikale Einbaulage	 Pozisyon 4 - 6 gövde büyüklüğü için Position for sizes 4 - 6 Lage bei Größen 4 - 6	

Şaft keçesi, labirent keçe uygulanması mümkün değildir.

- Vidalanarak uygulanan ısıtıcı aksamının Teknik verileri ve bilgileri:
Koruma sınıfı: IP 65,
230 V, 50 Hz, Güç değeri ilgili tasarıma bağlıdır. (Mutlaka PGR ile görüşülmelidir)
- Sıcaklık kontrol göstergeleri ATH-SW22
Teknik verileri ve bilgileri:
Koruma sınıfı: IP 65,
Açma kapama anahtarları (ayarlanabilir),
Maks. Çalışma Kapasitesi: 2A/230 V
AC/460 VA $\cos \varphi = 0.6$ (Alternatif Akım)
0,25 A/230 V DC/58 W (Doğru Akım)
- Aşağıda belirtilen modellerde yoktur
4, 6, 8, 10, 12, 14, 16, 18
Yağlama için gereken sınır değerinin altına düşüldüğünde, mutlaka ısıtma çubukları kullanılmalıdır.
Redüktörün tasarımına bağlı olarak, vidalanarak uygulanan ısıtıcılar ve sıcaklık izleme göstergeleri, ayna görüntüsü dikkate alınarak, monte edilebilir.
Ölçüler, talep edildiğinde temin edilir.

Labyrinth seal not possible as shaft seal

- Screwed heating element;
Technical data and notes:
type of protection IP 65,
230V, 50 Hz, power rating depending on design (please refer to us)
- Temperature monitor ATH-SW22;
Technical data and notes:
type of protection IP 65,
2 change - over contacts (adjustable),
max. Switching capacity:
2 A/230 V AC/460 VA $\cos \varphi = 0.6$ (alternating current),
0,25 A/230 V DC/58 W (direct current)
- Not for sizes
4, 6, 8, 10, 12, 14, 16, 18
The use of heating elements will be necessary if the temperature limit for lubrication is undershot.
Depending on the desing, screwed heating elements and temperature monitors may be arranged mirror-inverted.
Diemensions on request

Labyrinthdichtung als Wellenabdichtung nicht möglich

- Einschraubheizkörper,
Technische Daten und Hinweise:
Schutzart IP 65,230 V,
50 Hz, Leistung je nach Auslegung
(Rückfrage erforderlich)
- Temperaturwächter ATH- SW22
Technische Daten und Hinweise:
Schutzart IP 65,2
Umschaltkontakte (einstellbar),
max Schaltleistung:
2 A/230 V AC/460 VA $\cos \varphi = 0.6$ (Wechselspannung),
0,25 A/230 V DC/58 W (Gleichspannung)
- Entfällt bei Größen
4, 6, 8, 10, 12, 14, 16, 18
Der Einsatz von Heizstäben ist erforderlich, wenn die Grenztemperatur zur Schmierung unterschritten wird.
Je nach Ausführung können Einschraubheizkörper und Temperaturwächter spiegelbildlich angeordnet sein.

Abmessungen auf Anfrage

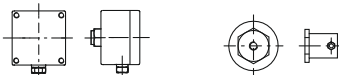

TR

YAĞ SICAKLIĞININ ÖLÇÜMÜ İÇİN
TERMOMETRELİ MODELLER

EN

WITH THERMOMETER FOR
OIL TEMPERATURE

DE

MIT OLTEMPERATURMESSUNG

Redüktör boyutu Gear unit size Getriebegröße	PH/PB4... - PH/PB12...	PH/PB13... - PH/PB18...
Yatay montaj pozisyonu Horizontal mounting position Horizontale Einbaulage		
Şaft Montajlı Dizayn Shaft-mounted design Aufsteck-ausführung		
Dikey montaj pozisyonu Vertical mounting position Vertikale Einbaulage		

PT 100 Rezistanlı Termometre Teknik Verileri ve Bilgileri:

Bağlantı başlığı koruma sınıfı:

IP 54, iki kablo bağlantılı.

Üç veya dört bağlantı kablolu uygulamalar, müşteri tarafından düzenlenebilir.

Mutlaka, bir değerlendirme cihazına bağlanmalıdır!

Tasarım modeline bağlı olarak, rezistanlı termometre, ayna görüntüsüne monte edilebilir.

Ölçüler, talep edildiğinde temin edilir.

Resistance thermometer PT 100 Technical data and notes:

Type of protection for terminal head:

IP 54, two-wire connection.

Three - and four - wire connection at the customer's is also possible.

Connection to an evaluation instrument is necessary!

Depending on the design, the resistance thermometer may be arranged mirror-inverted.

Labyrinth seal not possible as shaft seal.

Dimensions on request

Widerstandsthermometer PT 100 Technische Daten und Hinweise:

Schutzart Anschlußkopf: IP 54,

Zweileiterschaltung

Anschluß in Drei - bzw. Vierleiterschaltung kundenseitig ebenfalls möglich.

Anschluß an ein Auswertegerät erforderlich!

Je nach Ausführung kann das Widerstandsthermometer spiegelbildlich angeordnet sein.

Labyrinthdichtung als Wellenabdichtung nicht möglich.

Abmessungen auf Anfrage

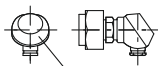

PG 9

Table 1 / Table 1 / Tabelle 1 Şaft Keçesi Çeşitleri / Wellenabdichtungsvarianten / Variants of shaft seals							
Tip Type Bauart	Gövde Size Größe	Döner mil keçesi Radial shaft seal Radialwellendichtring		Labirent keçe Labyrinth seal Labyrinthdichtung		Taconite keçe ¹⁾ Taconite seal Taconite-Dichtung	
		d1	d2	d1 ³⁾	d2	d1 ³⁾	d2
PH...1SH	31 - 171	H	H	H	H	H	H
PH...2	42 - 182	H / V	H / V	H	-	H / V	H / V
PH...3	53 - 183	H / V	H / V	-	-	H ²⁾ / V	H / V
PH...4	74 - 184	H / V	H / V	-	-	H / V	H / V
PB...2	42 - 182	H / V	H / V	-	-	H / V	H / V
PB...3	43 - 183	H / V	H / V	-	-	H / V	H / V
PB...4	54 - 184	H / V	H / V	-	-	H / V	H / V
	19... - 22...	İstek üzerine / On request / Auf Anfrage					

- H = Yatay
V = Dikey
1) Muhtemel uygulama şekilleri için, lütfen sonraki sayfalara bakınız.
2) Fanlı kombinasyon, talep üzerine temin edilir.
3) IEC Motorlu kombinasyon, mevcut değildir.
- H = Horizontal
V = Vertical
1) For possible design and restrictions, see the following pages.
2) Combination with fan on request
3) Not in combination with motor bell housing
- H = Horizontal
V = Vertikal
1) Mögliche Ausführungen und Einschränkungen siehe nachfolgende Seiten
2) Kombination mit Lüfter auf Anfrage
3) nicht in Kombination mit Motolaterne

Table 2 / Table 2 / Tabelle 2 Labirent keçeler için hız limitleri Speed limits for labyrinth seals / Grenzdrehzahlen für Labyrinthdichtungen																					
i _N	Redüktör gövdeleri / Gear unit sizes / Getriebegrößen																				
	3...	4...	5...	6...	7...	8...	9...	10...	11...	12...	13...	14...	15...	16...	17...	18...	19...	20...	21...	22..	
Giriş hızları / Input speeds / Eingangsdrehzahlen / n ₁ in / en min ⁻¹																					
1.25	x	-	x	-	x	-	x	-	-	-	-	-	-	-	-	-	-	-	-	-	-
1.4	x	-	x	-	x	-	x	-	-	-	-	-	-	-	-	-	-	-	-	-	-
1.6	740	-	515	-	425	-	370	-	305	-	260	-	-	-	-	-	-	-	-	-	-
1.8	810	-	570	-	460	-	395	-	325	-	285	-	-	-	-	-	-	-	-	-	-
2.0	860	-	610	-	490	-	420	-	350	-	305	-	255	-	-	-	-	-	-	-	-
2.24	920	-	660	-	550	-	455	-	375	-	330	-	275	-	-	-	-	-	-	-	-
2.5	1020	-	710	-	595	-	495	-	405	-	355	-	295	-	-	-	-	-	-	-	-
2.8	1100	-	775	-	635	-	530	-	445	-	390	-	320	-	290	-	-	-	-	-	-
3.15	1190	-	850	-	690	-	600	-	480	-	430	-	350	-	315	-	-	-	-	-	-
3.55	1300	-	935	-	755	-	650	-	530	-	470	-	380	-	345	-	-	-	-	-	-
4.0	1430	-	1025	-	835	-	720	-	580	-	515	-	420	-	380	-	-	-	-	-	-
4.5	1575	-	1145	-	905	-	770	-	640	-	575	-	475	-	425	-	-	-	-	-	-
5.0	1730	-	1205	-	990	-	850	-	730	-	605	-	525	-	455	-	-	-	-	-	-
5.6	1910	-	1340	-	1095	-	955	-	765	-	670	-	580	-	505	-	-	-	-	-	-
6.3	-	x	x	-	x	-	515	-	x	-	370	-	305	-	260	-	-	-	-	-	-
7.1	-	x	810	-	660	-	570	-	460	-	395	-	325	305	385	260	-	-	-	-	-
8.0	-	1020	860	x	705	x	610	x	490	x	420	370	350	325	305	385	-	-	-	-	-
9.0	-	1080	920	x	760	660	660	x	550	x	455	395	375	350	330	305	-	-	-	-	-
10	-	1190	1020	860	820	705	710	610	595	x	495	420	405	375	355	330	-	-	-	-	-
11.2	-	1280	1100	920	885	760	775	660	635	550	530	455	445	405	390	355	-	-	-	-	-
12.5	-	1435	1190	1020	955	820	850	710	690	595	600	495	480	445	430	390	-	-	-	-	-
14.0	-	1560	1300	1100	1090	885	935	775	755	635	650	530	530	480	470	430	-	-	-	-	-
16.0	-	1715	1430	1190	1200	955	1025	850	835	690	720	600	580	530	515	470	-	-	-	-	-
18.0	-	1890	1575	1300	1320	1090	1145	935	905	755	770	650	640	580	575	515	-	-	-	-	-
20.0	-	-	1730	1430	1450	1200	1205	1025	990	835	850	720	730	640	605	575	-	-	-	-	-
22.4	-	-	1910	1575	1530	1320	1340	1145	1095	905	x	770	x	730	x	605	-	-	-	-	-
25.0	-	-	1075	1730	885	1450	740	1205	x	990	x	850	x	x	x	x	-	-	-	-	-
28.0	-	-	1170	1910	940	1530	810	1340	x	1095	x	x	x	x	x	x	-	-	-	-	-

X = Labirent keçe uygulanması mümkün değildir. En düşük giriş devir sayısı olan n₁'in altına düşülmesi durumunda, radyal keçeler kullanılmalıdır.

X = Labyrinth seals are not possible. If the minimum input speed n₁ undershot, radial shaft seals are to be provided.

X = Labyrinth nicht möglich. Bei Unterschreitung der Mindest-Eingangsdrehzahl n₁ sind Radialwellendichtungen vorzusehen.

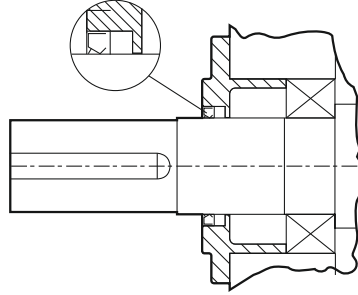
TR SAFT KEÇELERİ - DÖNER MİL KEÇESİ -
LABIRENT KEÇELEREN SHAFT SEALS - RADIAL SHAFT SEAL -
LABYRINTH SEALSDE WELLENABDICHTUNGEN -
RADIALWELLENDICHTRINGE -
LABYRINTHDICHTUNGENDöner mil keçesi
Radial shaft seals
Radialwellendichtringe

Radyal keçe uygulaması, düşük ile orta çalışma devir sayılarına uygundur.

Diğer bilgiler:

Aşınan keçe bakımı kolaydır, ancak:

Oluşan ısı nedeniyle, sızdırmazlık unsurlarının kenarlarında kısmi yıpranma meydana gelir, bu nedenle gereken şekilde yağlanmalıdır (soğutma).

Ticari bir üründür ve piyasadan kolayca temin edilebilir. Tamirat gerekmesi durumunda, flanş mili modellerde parçalı mil sızdırmazlık keçeleri kullanılmalıdır (Lütfen PGR ile görüşün).

Düşük yağ seviyeli modeller, talep üzerine temin edilir. Radyal mil keçeleri, tüm redüktör modellerin de ve tüm boyutlarında kullanılabilir.

Radial shaft seal are suitable for low average operating speeds.

Other features are:

Wearing seal, however, easy to maintain;

Local heat development on sealing lip; therefore, adequate lubrication (cooling) required;

Commercial product;

For the design with flanged shaft split shaft seals are to be used in case of repair (please refer to us);

Design with low oil level on request.

Radial shaft seals can be used for all types and sizes

Abdichtungen durch Radialwellendichtringe sind für niedrige bis mittlere Betriebsdrehzahlen geeignet.

Weitere Merkmale sind:

Verschleißende Dichtung, jedoch wartungsfreundlich, Lokale Wärmeentwicklung an Dichtlippe, deshalb ausreichend Schmierung (Kühlung) erforderlich,

Handelsübliches Produkt,

Bei Flanschwellenausführung sind im Reparaturfall geteilte Wellendichtringe einzusetzen (Rücksprache erforderlich),

Ausführung mit niedrigem Ölstand auf Anfrage.

Radialwellendichtringe können bei allen Bauarten und Größen eingesetzt werden.

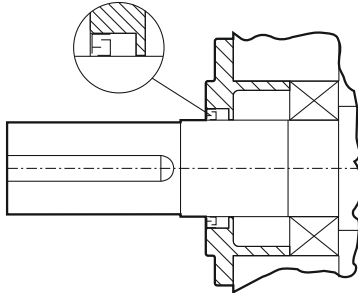
Labirent keçeler
Labyrinth seals
Labyrinthdichtungen

Özellikle yüksek devir sayılarında, labirent keçeler uygundur.

Diğer avantajları:

- Temassızdır ve bu sayede, aşınmaya dayanıklıdır.
- Noktasal ısı oluşumları yoktur, bu nedenle bakım gerektirmez.
- Büyük montaj alanları gerektirmez.

Labirent keçe seçiminde, aşağıda belirtilen kriterlere dikkat edilmelidir:

- Sadece sabit hareket mekanizmalarında kullanılır (Örneğin hareketli araçların motorlarında kullanılmamalıdır).
- Sadece daldırma yöntemi uygulanarak yağlanmalıdır (Basınçlı yağlama, talep üzerine temin edilir).
- Kurulumu, aşırı kirli veya pis suya maruz kalabileceği yerlerden, kaçınılmalıdır.
- Millerin mutlaka yatay (su terazisi) seviyesi sağlanmalıdır.
- Helisel dişli redüktörler için gereken en düşük giriş devir sayısı n1 için, lütfen tablo 2'ye bakınız.
- Düşük devir sayılarındaki çalışma sürelerinin uzun olması durumunda (örneğin kağıt makinelerindeki ağır hareketler gibi), mutlaka özel tedbirler (pislik ve kir tutucu plakalar) alınmalıdır.

Labyrinth seals are specially suitable for higher operating speeds.

Further advantages are:

- Non-contacting and thus, wear-resistant;
- No local heat development and thus, maintenance-free;
- Small space required for fitting.

For the selection of labyrinth seals the following criteria are to be considered:

- Applicable in stationary drives only (e.g. not in travelling gears);
- Only in case of dip lubrication (forced lubrication on request);
- Avoid extremely dusty environments or sites endangered by muddy water;
- Shaft levels must be horizontal;
- For min. required input speed n1 for helical gear units, see table 2;
- In case of longer operating periods at minimum speeds (e.g. creep speed in case of paper machines) special measures (oil retaining plates) are required.

Die Labyrinthdichtungen sind für höhere Betriebsdrehzahlen besonders geeignet.

Weitere Vorzüge sind:

- Berührungslos und somit verschleißfrei,
- Keine lokale Wärmeentwicklung, somit wartungsfrei,
- Geringer Eibauraum.

Bei der Auswahl der Labyrinthdichtungen sind folgende Kriterien zu berücksichtigen:

- Nur bei stationären Antrieben einsetzen (z.B. keine Fahrwerke),
- Nur bei Tauchschmierung, Druckschmierung auf Anfrage),
- Extrem staubige oder durch Schmutzwasser gefährdete Aufstellungsorte meiden,
- Wellenebenen müssen Waagrecht sein,
- Erforderliche Mindest - Eingangsdrehzahl n1 für Stirnradgetriebe siehe Tabelle 2,
- Bei längerer Betriebsdauer mit minimalen Drehzahlen (z.B. Kriechbetrieb bei Papiermaschinen) sind besondere Maßnahmen (Ölstableche) erforderlich.

Taconite Keçeler
Taconite seals
Taconite - Dichtungen

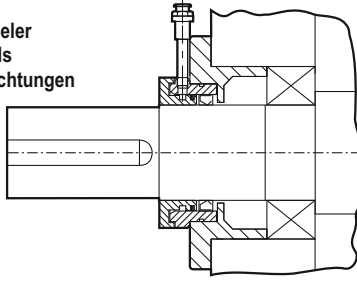

Yağ dolumu ve yeniden yağ dolumu yapılabilir tipte labirent keçe aksamları kombine edilmelidir. Bu sızdırmazlık yöntemi, özellikle kirlı ortamlarda yüksek düzeyde iş güvenliği sağlar. Redüktöre kir ve pislik parçacıklarının girmesini kesin bir şekilde önlemek için, bu üç farklı sızdırmazlık unsuru kombine edilerek uygulanmalıdır.

Grease-filled, refillable labyrinth seal combinations. With this seal a high degree of operational reliability is achieved for the gear unit in dusty environments. This seal is a combination of three sealing elements which protect the gear unit from ingress of dust-like particles.

Fettgefüllte, nachschmierbare Labyrinth-Dichtungskombinationen. Mit dieser Dichtung erlangt das Getriebe in staubiger Umgebung ein hohes Maß an Betriebssicherheit. Die Dichtung ist eine Kombination von drei Dichtungselementen, die das Getriebe vor dem Eindringen staubartiger Partikel schützen.

Keçe Dichtung Seal Taconite	Mil Shaft Welle	Not Note Hinweis	Tablo 3 / Table 3 / Tabelle 3					
E	Giriş mili Input shaft Antriebswelle	3 ve 4 kademelilerin ölçülerine dikkat edin / Take into account dimensions for 3 and 4 / Abmessungen für 3 und 4 beachten	G1 Ölçüsüne ve mil ölçülerine, Taconite keçe uygulanmalıdır "E" G1 Dimension and shaft dimensions for Taconite "E" G1 Maß und Wellenabmessungen bei Taconite "E"					
	F		Çıkış millii Solid shaft Vollwelle	Boyutlar 8'den itibaren / from size 8 on / erst ab Größe 8	Tip Type Bauart	Gövde Size Größe	Tahvil / Ratio Übersetzung (i)	G1
Güçlendirilmiş çıkış şaftı d2 Reinforced output shaft d2 Abtriebswelle d2 verstärkt		PH...3	93		25 - 45 50 - 63 71 - 90	250	60 m6 45 m6 32 m6	105 80 60
F-F	Kamalı, delik millii Hollow shaft with keyway Hohlwelle mit Passfedernut		Kazayla temas etmeye karşı, koruyucu kapağın her iki tarafına Taconite keçe uygulanmalıdır. Taconite seals on both sides Guard as protection against accidental contact	103	31.5 - 56 63 - 80 90 - 112	250	60 m6 45 m6 32 m6	105 80 60
	Spline, Delik millii DIN 5480 Hollow shaft with involute splines acc. to DIN 5480 Hohlwelle mit Zahnablenprofil nach DIN 5480	113		25 - 45	275	70 m6	100	
F-H	Kamalı, Delik millii Hollow shaft with keyway Hohlwelle mit Passfedernut	Müşteri milinin karşısında bulunan ve toz geçirmemesi için koruyucu kapaklı tarafa, Taconite keçe uygulanmalıdır. Taconite seal on driven machine shaft Dustproof guard on opposite side Taconite-Dichtung an der Arbeitsmaschinenwelle gegenüberliegende Seite mit staubdichter Schutzhaube	123	31.5 - 56	275	70 m6	100	
	Spline, Delik millii DIN 5480 Hollow shaft with involute splines acc. to DIN 5480 Hohlwelle mit Zahnablenprofil nach DIN 5480		133	22.4 - 45 50 - 63 71 - 90	340	85 m6 60 m6 50 m6	130 105 80	
F-K	Delik millii / Konik sıkırtmalı Hollow shaft for shrink disk Hohlwelle für Schrupfscheibe	Müşteri milinin karşısında bulunan ve toz geçirmemesi için koruyucu kapaklı tarafa, Taconite keçe uygulanmalıdır. Taconite seal on driven machine shaft Dustproof guard on opposite side Taconite - Dichtung an der Arbeitsmaschinenwelle gegenüberliegende Seite mit staubdichter Schutzhaube	143	28 - 56 63 - 80 90 - 112	340	85 m6 60 m6 50 m6	130 105 80	
			153	22.4 - 45 50 - 63 71 - 90	385	100 m6 75 m6 60 m6	165 105 105	
F-K	Delik millii / Konik sıkırtmalı Hollow shaft for shrink disk Hohlwelle für Schrupfscheibe	Müşteri milinin karşısında bulunan ve toz geçirmemesi için koruyucu kapaklı tarafa, Taconite keçe uygulanmalıdır. Taconite seal on driven machine shaft Dustproof guard on opposite side Taconite - Dichtung an der Arbeitsmaschinenwelle gegenüberliegende Seite mit staubdichter Schutzhaube	163	25 - 50 56 - 71 80 - 100	385	100 m6 75 m6 60 m6	165 105 105	
			173	22.4 - 45 50 - 63 71 - 90	415	100 m6 75 m6 60 m6	165 105 105	
F-K	Delik millii / Konik sıkırtmalı Hollow shaft for shrink disk Hohlwelle für Schrupfscheibe	Müşteri milinin karşısında bulunan ve toz geçirmemesi için koruyucu kapaklı tarafa, Taconite keçe uygulanmalıdır. Taconite seal on driven machine shaft Dustproof guard on opposite side Taconite - Dichtung an der Arbeitsmaschinenwelle gegenüberliegende Seite mit staubdichter Schutzhaube	183	25 - 50 56 - 71 80 - 100	415	100 m6 75 m6 60 m6	165 105 105	
			PH...4	114	100 - 180 200 - 355	270	45 m6 32 m6	80 60
F-K	Delik millii / Konik sıkırtmalı Hollow shaft for shrink disk Hohlwelle für Schrupfscheibe	Müşteri milinin karşısında bulunan ve toz geçirmemesi için koruyucu kapaklı tarafa, Taconite keçe uygulanmalıdır. Taconite seal on driven machine shaft Dustproof guard on opposite side Taconite - Dichtung an der Arbeitsmaschinenwelle gegenüberliegende Seite mit staubdichter Schutzhaube	124	125 - 224 250 - 450	270	45 m6 32 m6	80 60	
			134	100 - 180 200 - 355	325	50 m6 38 m6	80 60	
F-K	Delik millii / Konik sıkırtmalı Hollow shaft for shrink disk Hohlwelle für Schrupfscheibe	Müşteri milinin karşısında bulunan ve toz geçirmemesi için koruyucu kapaklı tarafa, Taconite keçe uygulanmalıdır. Taconite seal on driven machine shaft Dustproof guard on opposite side Taconite - Dichtung an der Arbeitsmaschinenwelle gegenüberliegende Seite mit staubdichter Schutzhaube	144	125 - 224 250 - 450	325	50 m6 38 m6	80 60	
			154	100 - 180 200 - 355	375	60 m6 50 m6	105 80	
F-K	Delik millii / Konik sıkırtmalı Hollow shaft for shrink disk Hohlwelle für Schrupfscheibe	Müşteri milinin karşısında bulunan ve toz geçirmemesi için koruyucu kapaklı tarafa, Taconite keçe uygulanmalıdır. Taconite seal on driven machine shaft Dustproof guard on opposite side Taconite - Dichtung an der Arbeitsmaschinenwelle gegenüberliegende Seite mit staubdichter Schutzhaube	164	112 - 200 224 - 400	375	60 m6 50 m6	105 80	

TR IEC STANDARTINDAKİ MOTORLAR
İÇİN ÖLÇÜLEREN FITTING DIMENSION FOR IEC
STANDARD MOTORS

DE ANBAUMÄßE FÜR IEC-NORMMOTOREN

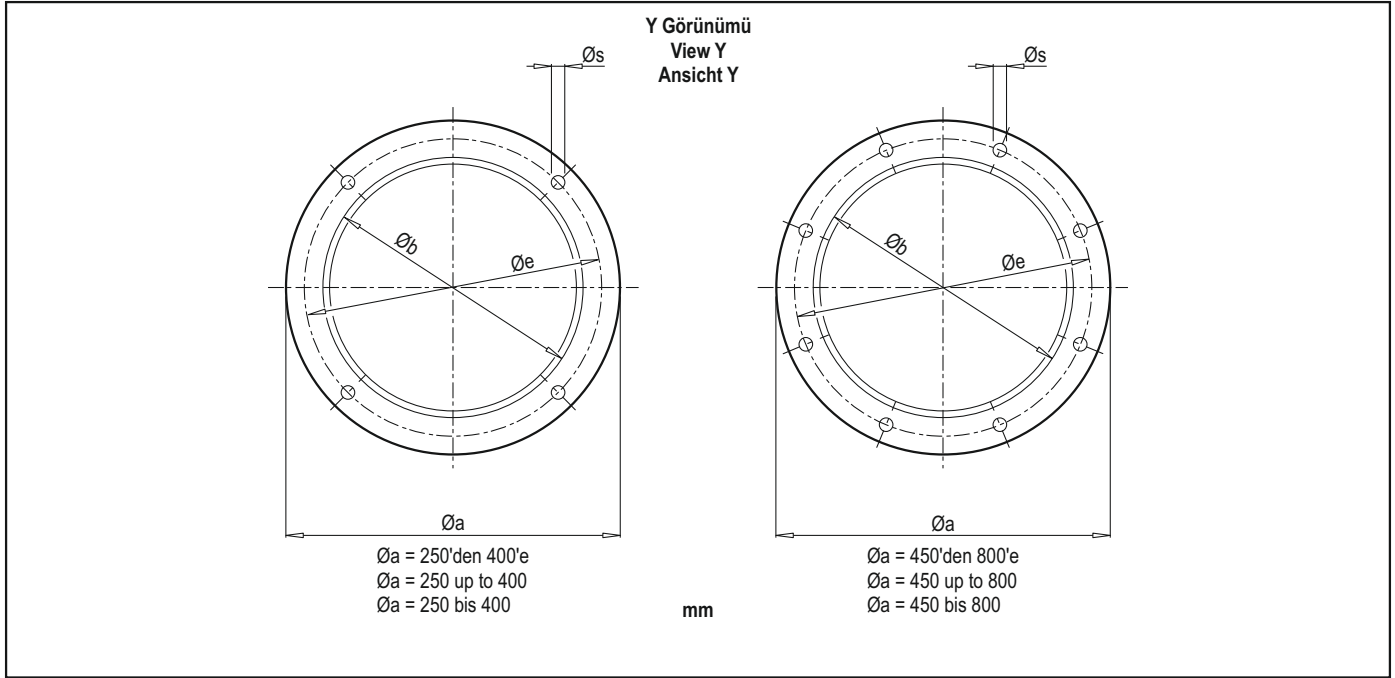

Tablo 1 / Table 1 / Tabelle 1

Flanş ölçüleri / Flange dimensions / Flanschabmessungen

Üç fazlı, sincap kafesli rotor DIN 42677 Part 1'e göre
Three-phase motors with squirrel-cage rotor acc.to DIN 42677 Part 1
Drehstrommotoren mit Käfigläufer nach DIN 42677 Teil 1

Motor büyüklüğü / Motor sizes / Motorbaugrößen

	100 L	112 M	132 S	132 M	160 M	160 L	180 M	180 L	200 L	225 S	225 M	250 M	280 S	280 M	315 S	315 M
Øa	250	250	300	300	350	350	350	350	400	450	450	550	550	550	660	660
Øb	180	180	230	230	250	250	250	250	300	350	350	450	450	450	550	550
Øe	215	215	265	265	300	300	300	300	350	400	400	500	500	500	600	600
Øs	4 x M12	4 x M12	4 x M12	4 x M12	4 x M16	4 x M16	4 x M16	4 x M16	4 x M16	8 x M16	8 x M16	8 x M16	8 x M16	8 x M16	8 x M20	8 x M20

TR

KAPLIN B
IEC BAĞLANTILI MOTORLAR

EN

MOTOR BELL HOUSING FOR
IEC STANDARD MOTORS WITH
B COUPLING

DE

MOTORKUPPLUNG FÜR IEC -
MOTOREN MIT B - KUPPLUNG

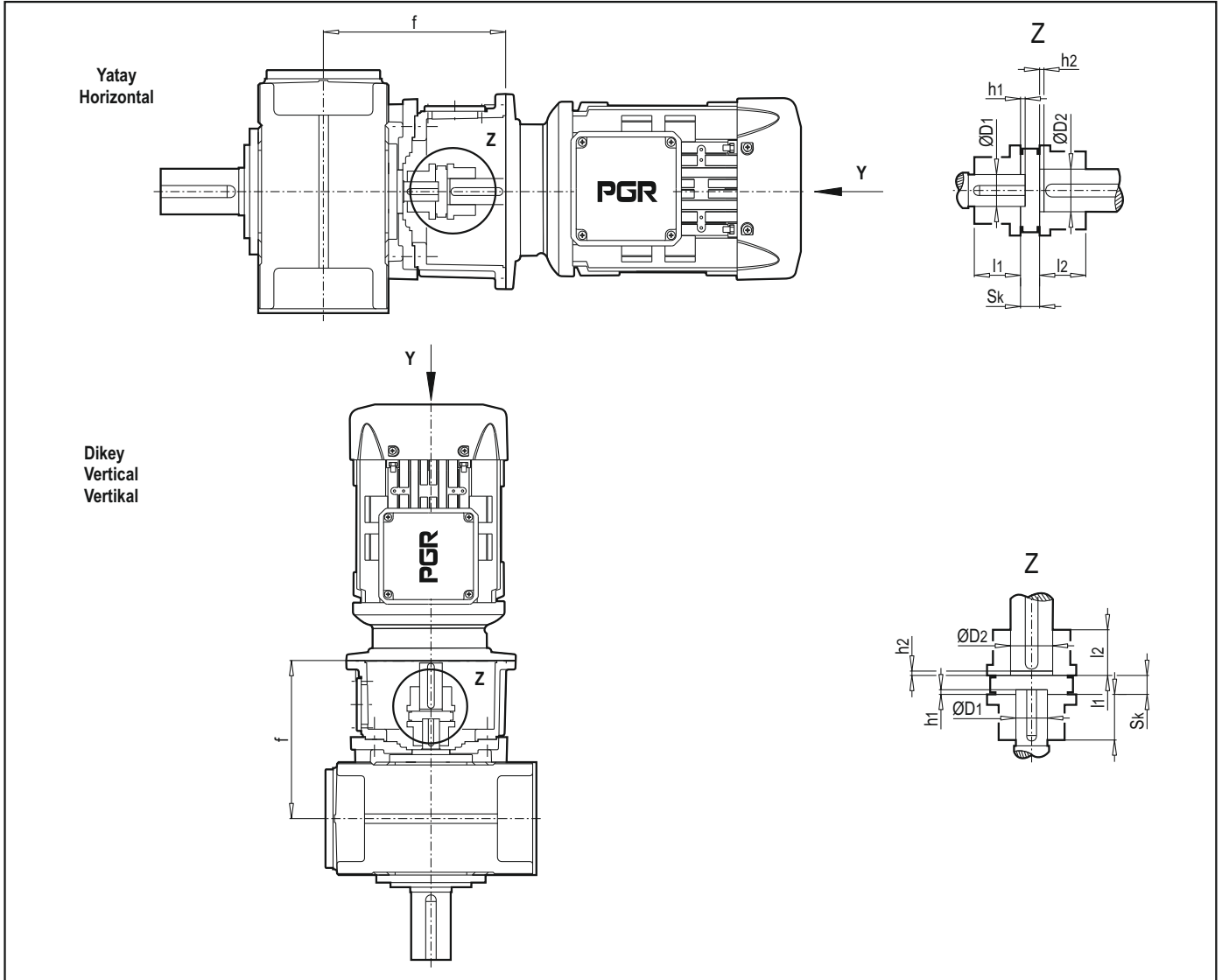

Özel tasarım gerektiren tesisler için (yüksek açma kapama frekansı ve değişken yük yönleri, örneğin kaldırma makinaları, hareketli taşıtlar ve benzeri), güncel ve geçerli kaplin kataloğundan kontrol edilerek, uygun kaplin seçimi yapılır. Bunlardan farklı kaplin gerektiren durumlarda, mutlaka PGR ile görüşülmelidir!

For plants with special design requirements (high switching frequency, alternating direction of load; e.g. hoisting gears, travelling gears, etc) the coupling design is to be checked in accordance with the respective valid coupling brochure. For other couplings, please consult PGR!

Bei Anlagen mit besonderen Auslegungsanforderungen (große Schaltfrequenz, wechselnde Lastichtung; z.B. Hubwerke, Fahrwerke, usw.) ist die Auslegung der Kupplung nach dem jeweils gültigen Kupplungskatalog zu prüfen. Bei abweichenden Kupplungen ist Rücksprache mit PGR notwendig!

DIN 42677 IEC - Standart motorlarının montaj ölçüleri (Y bakış açısı) için, sayfa 162'ye bakın. C,D,G,H,I modeli helisel dişli redüktörlerde, giriş milinde takonite E veya labirent keçe uygulaması yoktur, ancak talep üzerine uygulanır.

For fitting dimensions for IEC standard motors DIN 42677 (View Y), see page 162. Helical gear unit in C, D, G, H, I, design on request only. Not in connection with Taconite E or labyrinth seal on input shaft.

Anbaumaße für IEC-Normmotoren DIN 42677 (Ansicht Y) siehe Seite 162. Stinradgetriebe in Ausführung C, D, G, H, I nur auf Anfrage. Nicht in Verbindung mit Taconite E oder Labyrinth-Abdichtung an der Antriebswelle

- 1) Diğer motor büyüklükleri, talep üzerine temin edilir.
- 2) Sadece 315S ve 315M tipi imalat büyüklükleri.
- 4) Sadece dikey redüktörler için.
- 5) PH...2-D imalat modellerinin A+B uygulama tiplerine montajı mümkün değildir.
- 6) PH...2-D imalat modellerinin 5 gövde büyüklüğünün A+B uygulama tiplerine montajı mümkün değildir.
- 7) PH...2-D imalat modellerinin 7 gövde büyüklüğünün A+B uygulama tiplerine montajı mümkün değildir.
- 8) PH...2-DV imalat modellerinin 9 gövde büyüklüğünün A+B uygulama tiplerine montajı mümkün değildir.

- 1) Other motor sizes on request
- 2) Sizes 315S and 315M only
- 4) For vertical gear units only
- 5) For type PH...2-D design A+B; fitting not possible.
- 6) For type PH...2-D size 5 design A+B; fitting not possible.
- 7) For type PH...2-D size 7 design A+B; fitting not possible.
- 8) For type PH...2-DV size 9 design A+B; fitting not possible.

- 1) Andere Motorgrößen auf Anfrage
- 2) Nur Baugröße 315S und 315M
- 4) Nur für Vertikalgetriebe
- 5) Bei Bauart PH...2-D Ausführung A+B; Anbau nicht möglich.
- 6) Bei Bauart PH...2-D Größe 5 Ausführung A+B; Anbau nicht möglich.
- 7) Bei Bauart PH...2-D Größe 7 Ausführung A+B; Anbau nicht möglich.
- 8) Bei Bauart PH...2-DV Größe 9 Ausführung A+B; Anbau nicht möglich.

TR

KAPLİN B
IEC BAĞLANTILI MOTORLAR

EN

MOTOR BELL HOUSING FOR
IEC STANDARD MOTORS WITH
B COUPLING

DE

MOTORLATERNE FÜR IEC -
MOTOREN MIT B - KUPPLUNG

Tablo 2 / Table 2 / Tabelle 2																					
Gövde Size Größe	Motor IEC ¹⁾	Tahvil İN / Ratios İN / Übersetzungen İN 6.3 -11.2 (Gövdeler / Sizes / Größen 42,52,72,92,112) 8 - 14 (Gövdeler / Sizes / Größen 62,82,102,122)										Tahvil İN / Ratios İN / Übersetzungen İN 12.5 - 22.4 (Gövdeler / Sizes / Größen 42,52,72,92,112) 16 - 28 (Gövdeler / Sizes / Größen 62,82,102,122)									
		Kaplin B B Coupling B Kupplung BWN	mm										Kaplin B B Coupling B Kupplung BWN	mm							
			sk	l1	ØD1	l2	ØD2	h1	h2	f	sk	l1		ØD1	l2	ØD2	h1	h2	f		
42	160 5)	-	-	-	-	-	-	-	-	-	-	84	21	40	32	40	42	11	0	370	
	180 5)	-	-	-	-	-	-	-	-	-	-	97	24	50	32	50	48	14	0	370	
	200 5)	-	-	-	-	-	-	-	-	-	-	112	27	60	32	60	55	11	0	376	
	225 5) 4)	127	27	65	45	65	60	20	0	417	4)	127	27	65	32	65	60	0	0	417	
52 / 62	200	-	-	-	-	-	-	-	-	-	-	112	27	60	38	60	55	10	0	402	
	225 6)	-	-	-	-	-	-	-	-	-	-	127	27	65	38	65	60	-1	0	443	
	250 5) 4)	127	27	65	50	65	65	17.5	0	444.5	4)	127	27	65	38	65	65	-2.5	0	444.5	
72 / 82	225	-	-	-	-	-	-	-	-	-	-	127	27	65	50	65	60	13.5	0	473.5	
	250 7)	-	-	-	-	-	-	-	-	-	-	127	27	65	50	65	65	12	0	475	
	280 7)	-	-	-	-	-	-	-	-	-	-	142	31	75	50	75	75	-3	0	494	
	315 2) 5) 4)	162	36	80	60	80	80	20	0	531	4)	162	36	80	50	80	80	-2.5	2.5	531	
92 / 102	280	-	-	-	-	-	-	-	-	-	-	142	31	75	60	75	75	22	0	530	
	315 2) 8) 4)	162	36	80	75	80	80	20	0	566	4)	162	36	80	60	80	80	20	0	566	
112 / 122	315 2)	-	-	-	-	-	-	-	-	-	-	162	36	80	70	80	80	15	0	606	

TR

KAPLIN B
IEC BAĞLANTILI MOTORLAR

EN

MOTOR BELL HOUSING FOR
IEC STANDARD MOTORS WITH
B COUPLING

DE

MOTORKUPPLUNG FÜR IEC -
MOTOREN MIT B - KUPPLUNG

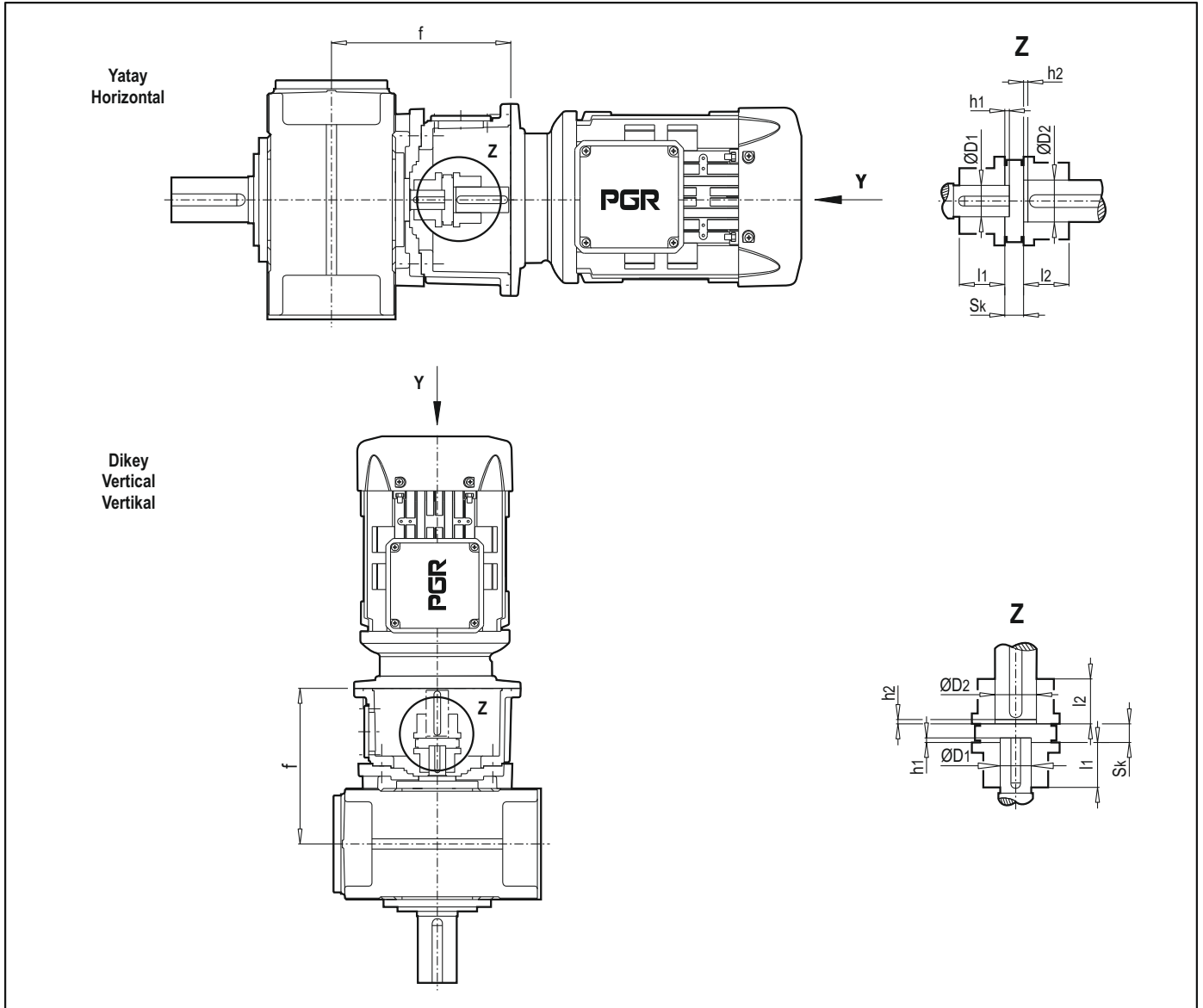

Özel tasarım gerektiren tesisler için (yüksek açma kapama frekansı ve değişken yük yönleri, örneğin kaldırma makineleri, hareketli taşıtlar ve benzeri), güncel ve geçerli kaplin kataloğundan kontrol edilerek, uygun kaplin seçimi yapılır. Bunlardan farklı kaplin gerektiren durumlarda, mutlaka PGR ile görüşülmelidir!

DIN 42677 IEC - Standart motorlarının montaj ölçüleri (Y bakış açısı) için, sayfa 162'ye bakın. C, D, G, H, I modeli helisel dişli redüktörlerde, giriş milinde takonite E veya labirent keçe uygulaması yoktur, ancak talep üzerine uygulanır.

For plants with special design requirements (high switching frequency, alternating direction of load; e.g. hoisting gears, travelling gears, etc) the coupling design is to be checked in accordance with the respective valid coupling brochure. For other couplings, please consult PGR!

For fitting dimensions for IEC standard motors DIN 42677 (View Y), see page 162. Helical gear unit in C, D, G, H, I, design on request only.

Not in connection with Taconite E or labyrinth seal on input shaft.

Bei Anlagen mit besonderen Auslegungsanforderungen (große Schalthäufigkeit, wechselnde Lastrichtung; z.B. Hubwerke, Fahrwerke, usw) ist die Auslegung der Kupplung nach dem jeweils gültigen Kupplungskatalog zu prüfen. Bei abweichenden Kupplungen ist Rücksprache mit PGR notwendig!

Anbaumaße für IEC - Normmotoren DIN 42677 (Ansicht Y) siehe Seite 162.

Stirradgetriebe in Ausführung C, D, G, H, I nur auf Anfrage. Nicht in Verbindung mit Taconite E oder Labyrinth-Abdichtung an der Antriebswelle

- 1) Diğer motor büyüklükleri, talep üzerine temin edilir.
- 2) Sadece 315S ve 315M motor büyüklükleri.
- 3) Redüktör miline oturan kaplin göbeğinin l1 uzunluğu kısaltılmıştır.
- 4) Sadece dikey redüktörler için.

- 1) Other motor sizes on request
- 2) Sizes 315S and 315M only
- 3) Length l1 of Coupling hub shortened for fitting onto gear unit shaft.
- 4) For vertical gear unit only

- 1) Andere Motorgrößen auf Anfrage
- 2) Nur Baugröße 315S und 315M
- 3) Länge l1 der Kupplungsnabe zum Aufsetzen Auf Getriebewelle gekürzt
- 4) Nur für Vertikalgetriebe

TR KAPLIN B
IEC BAĞLANTILI MOTORLAR

EN MOTOR BELL HOUSING FOR IEC
STANDARD MOTORS WITH
B COUPLING

DE MOTORLATERNE FÜR IEC -
MOTOREN MIT B - KUPPLUNG

Tablo 3 / Table 3 / Tabelle 3

Gövde Size Größe	Motor ¹⁾ IEC	Tahvil İN / Ratios İN / Übersetzungen İN 25 - 45 (Gövde/Size/Größe 53,73,93,113) 31,5 - 56(Gövde/Size/Größe 63,83,103,123) 22,4 - 45(Gövde/Size/Größe 133,153,173) 28 - 56 (Gövde/Size/Größe 143) 25 - 50 (Gövde/Size/Größe 163,183)										Tahvil İN / Ratios İN / Übersetzungen İN 50 - 63 (Gövde/Size/Größe 53,73,93,113) 63 - 80 (Gövde/Size/Größe 63,83,103,123) 50 - 63 (Gövde/Size/Größe 133,153,173) 63 - 80 (Gövde/Size/Größe 143) 56 - 71 (Gövde/Size/Größe 163,183)										Tahvil İN / Ratios İN / Übersetzungen İN 71 - 90 (Gövde/Size/Größe 53,73,93,113) 90 - 112 (Gövde/Size/Größe 63,83,103,123) 71 - 90 (Gövde/Size/Größe 133,153,173) 90 - 112 (Gövde/Size/Größe 143) 80 - 100 (Gövde/Size/Größe 163,183)									
		mm										mm										mm									
		Kaplin B B Coupling B Kupplung BWN	sk	l1	ØD1	l2	ØD2	h1	h2	f		Kaplin B B Coupling B Kupplung BWN	sk	l1	ØD1	l2	ØD2	h1	h2	f		Kaplin B B Coupling B Kupplung BWN	sk	l1	ØD1	l2	ØD2	h1	h2	f	
53 / 63	132	-	-	-	-	-	-	-	-	-	-	-	-	-	-	-	-	-	-	72	18	35	24	35	38	-2	-2	302			
	160	84	21	40	40	40	42	-1.5	1.5	364	84	21	40	30	40	42	3	0	338	84	21	40	24	40	42	-7	0	338			
	180	97	24	50	40	50	48	0	0	364	3)	97	24	44	30	50	48	6	0	338	3)	97	24	44	24	50	48	-4	0	338	
	200	3)	112	27	53	40	60	55	17	0	350	3)	112	27	53	30	60	55	-3	0	350	-	-	-	-	-	-	-	-	-	
	225	3)	127	27	60	40	65	60	6	0	391	-	-	-	-	-	-	-	-	-	-	-	-	-	-	-	-	-	-		
	250	3) 4)	127	27	60	40	65	65	6	0	391	-	-	-	-	-	-	-	-	-	-	-	-	-	-	-	-	-	-		
73 / 83	160	-	-	-	-	-	-	-	-	-	-	-	-	-	-	-	-	-	-	84	21	40	28	40	42	-1	0	367			
	180	-	-	-	-	-	-	-	-	-	3)	97	24	45	35	50	48	12	0	367	3)	97	24	45	28	50	48	2	0	367	
	200	112	27	60	45	60	55	-1.5	1.5	405	3)	112	27	55	35	60	55	3	0	379	3)	112	27	55	28	60	55	-7	0	379	
	225	127	27	65	45	65	60	12	0	420	127	27	65	35	65	60	-8	0	420	127	27	65	28	65	60	-18	0	420			
	250	127	27	65	45	65	65	12	0	420	127	27	65	35	65	65	-8	0	420	-	-	-	-	-	-	-	-	-			
	280	142	31	75	45	75	75	-4.5	0	440.5	-	-	-	-	-	-	-	-	-	-	-	-	-	-	-	-	-	-			
93 / 103	180	-	-	-	-	-	-	-	-	-	-	-	-	-	-	-	-	-	-	97	24	50	32	50	48	12.5	0	431.5			
	200	-	-	-	-	-	-	-	-	-	-	-	-	-	-	-	-	-	-	112	27	60	32	60	55	3.5	0	443.5			
	225	127	27	65	60	65	60	2.5	0	519.5	127	27	65	45	65	60	12.5	0	484.5	127	27	65	32	65	60	-3.75	-3.75	484.5			
	250	127	27	65	60	65	65	2.5	0	519.5	127	27	65	45	65	65	12.5	0	484.5	127	27	65	32	65	65	-3.75	-3.75	484.5			
	280	142	31	75	60	75	75	21	0	505	142	31	75	45	75	75	-2	2	505	-	-	-	-	-	-	-	-	-			
	315	2) 4)	162	36	80	60	80	80	19	0	542	4)	162	36	80	45	80	80	-3	3	542	-	-	-	-	-	-	-	-	-	
113 / 123	225	-	-	-	-	-	-	-	-	-	-	-	-	-	-	-	-	-	-	127	27	65	42	65	60	2.5	0	489.5			
	250	-	-	-	-	-	-	-	-	-	127	27	65	50	65	65	12.5	0	489.5	127	27	65	42	65	65	2.5	0	489.5			
	280	142	31	75	70	75	75	6	0	540	142	31	75	50	75	75	-4	0	510	142	31	75	42	75	75	-7	-7	510			
	315	2)	162	36	80	70	80	80	4	0	577	162	36	80	50	80	80	-6	0	547	162	36	80	42	80	80	-16	0	547		
133 / 143	250	-	-	-	-	-	-	-	-	-	-	-	-	-	-	-	-	-	-	127	27	65	50	65	65	8.5	0	578.5			
	280	-	-	-	-	-	-	-	-	-	142	31	75	60	75	75	17	0	599	142	31	75	50	75	75	-4	4	599			
	315	2)	182	42	90	85	90	80	13	-3	666	162	36	80	60	80	80	15	0	636	162	36	80	50	80	80	-5	5	636		
153 / 163	280	-	-	-	-	-	-	-	-	-	-	-	-	-	-	-	-	-	-	142	31	75	60	75	75	14	0	647			
	315	2)	-	-	-	-	-	-	-	-	162	36	80	75	80	80	12	0	684	162	36	80	60	80	80	12	0	684			
173 / 183	315	2)	-	-	-	-	-	-	-	-	-	-	-	-	-	-	-	-	-	162	36	80	60	80	80	12	0	714			

TR

KAPLİN B
IEC BAĞLANTILI MOTORLAR

EN

MOTOR BELL HOUSING FOR
IEC STANDARD MOTORS WITH
B COUPLING

DE

MOTORKATERNE FÜR IEC -
MOTOREN MIT B - KUPPLUNG

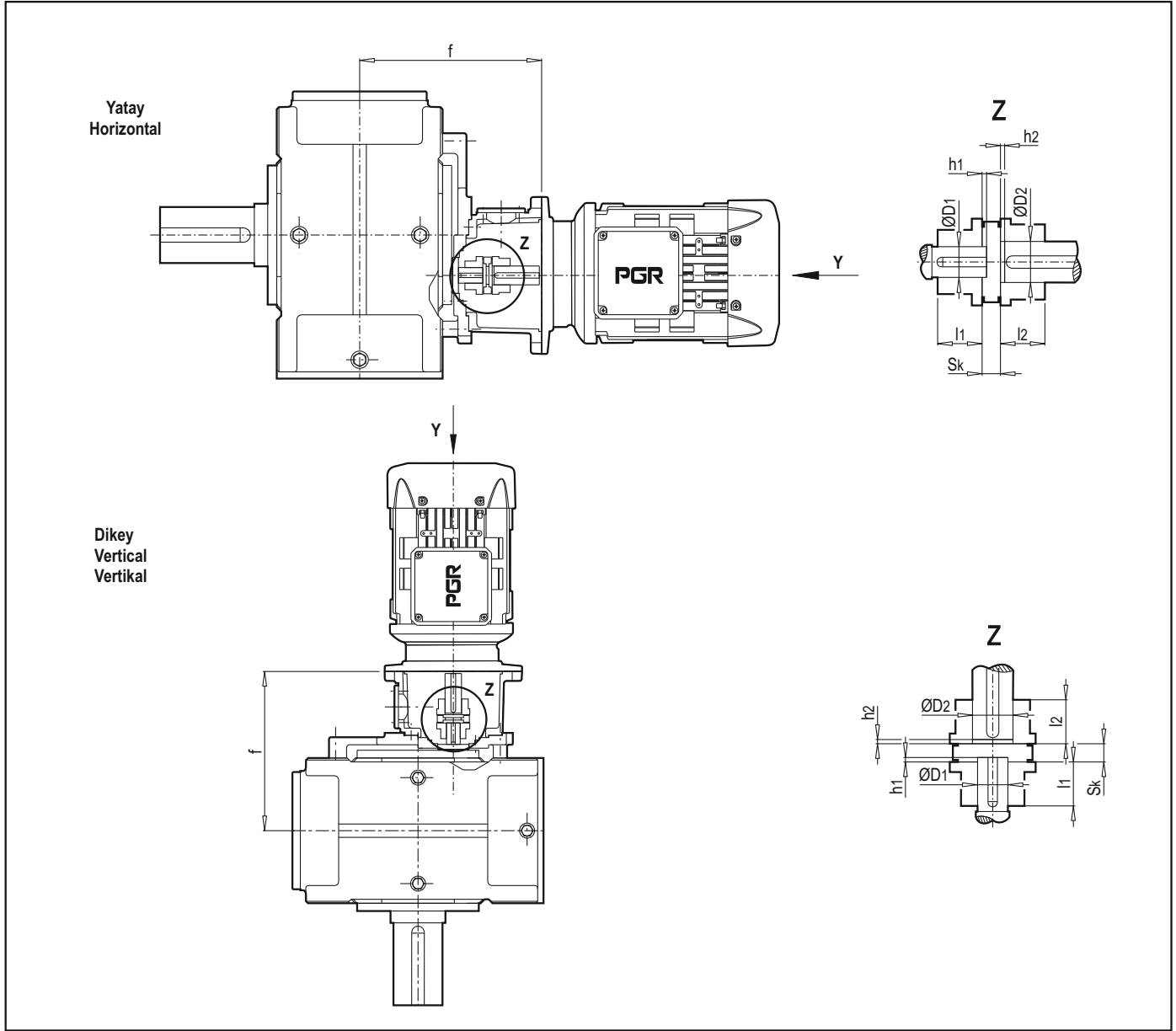

Özel tasarım gerektiren tesisler için (yüksek açma kapama frekansı ve değişken yük yönleri, örneğin kaldırma makinaları, hareketli taşıtlar ve benzeri), güncel ve geçerli kaplin kataloğundan kontrol edilerek, uygun kaplin seçimi yapılır. Bunlardan farklı kaplin gerektiren durumlarda, mutlaka PGR ile görüşülmelidir!

DIN 42677 IEC - Standart motorlarının montaj ölçüleri (Y bakış açısı) için, sayfa 162'ye bakın.

C, D, G, H, I modeli helisel dişli redüktörlerde, giriş milinde takonite E veya labirent keçe uygulaması yoktur, ancak talep üzerine uygulanır.

For plants with special design requirements (high switching frequency, alternating direction of load; e.g. hoisting gears, travelling gears, etc) the coupling design is to be checked in accordance with the respective valid coupling brochure. For other couplings, please consult PGR!

For fitting dimensions for IEC standard motors DIN 42677 (View Y), see page 162.

Helical gear unit in C, D, G, H, I, design on request only. Not in connection with Taconite E or labyrinth seal on input shaft.

Bei Anlagen mit besonderen Auslegungsanforderungen (große Schalthäufigkeit, wechselnde Lastrichtung; z.B. Hubwerke, Fahrwerke, usw) ist die Auslegung der Kupplung nach dem jeweils gültigen Kupplungskatalog zu prüfen. Bei abweichenden Kupplungen ist Rücksprache mit PGR notwendig!

Anbaumaße für IEC - Normmotoren DIN 42677 (Ansicht Y) siehe Seite 162.

Stinradgetriebe in Ausführung C, D, G, H, I nur auf Anfrage. Nicht in Verbindung mit Taconite E oder Labyrinth-Abdichtung an der Antriebswelle

1) Diğer motor büyüklükleri, talep üzerine temin edilir.

2) Sadece 315S ve 315M motor büyüklükleri.

3) Redüktör miline oturan kaplin göbeğinin l1 uzunluğu kısaltılmıştır.

1) Other motor sizes on request

2) Sizes 315S and 315M only

3) Length l1 of Coupling hub shortened for fitting onto gear unit shaft.

1) andere Motorgößen auf Anfrage

2) nur Baugröße 315S und 315M

3) Länge l1 der Kupplungsnahe zum Aufsetzen Auf Getriebewelle gekürzt.

TR

KAPLIN B
IEC BAĞLANTILI MOTORLAR

EN

MOTOR BELL HOUSING FOR
IEC STANDARD MOTORS WITH
B COUPLING

DE

MOTORKAPPE FÜR IEC -
MOTOREN MIT B - KUPPLUNG

Tablo 4 / Table 4 / Tabelle 4

Gövde Size Größe	Motor ¹⁾ IEC	Tahvil İN / Ratios İN / Übersetzungen İN 100 - 180 (Gövdeler / Sizes / Größen 74,94,114) 125 - 224 (Gövdeler / Sizes / Größen 84,104,124) 100 - 180 (Gövdeler / Sizes / Größen 134,154,174) 125 - 224 (Gövde / Size / Größe 144) 112 - 200 (Gövdeler / Sizes / Größen 164,184)										Tahvil İN / Ratios İN / Übersetzungen İN 200 - 355 (Gövdeler / Sizes / Größen 74,94,114) 250 - 450 (Gövdeler / Sizes / Größen 84,104,124) 200 - 355 (Gövdeler / Sizes / Größen 134,154,174) 250 - 450 (Gövde / Size / Größe 144) 224 - 400 (Gövdeler / Sizes / Größen 164,184)											
		Kaplin B B Coupling B Kupplung BWN	mm										Kaplin B B Coupling B Kupplung BWN	mm									
			sk	l1	ØD1	l2	ØD2	h1	h2	f	sk	l1		ØD1	l2	ØD2	h1	h2	f				
74 / 84	100	-	-	-	-	-	-	-	-	-	-	62	16	30	24	30	28	0	0	296			
	112	-	-	-	-	-	-	-	-	-	-	62	16	30	24	30	28	0	0	296			
	132	72	18	35	30	35	38	-0.5	0	328.5	72	18	35	24	35	38	-5.5	5	328.5				
	160	84	21	40	30	40	42	-3.5	0	364.5	84	21	40	24	40	42	-6.5	7	364.5				
	180	3)	97	24	42	30	50	48	-0.5	0	364.5	-	-	-	-	-	-	-	-				
94/104	132	-	-	-	-	-	-	-	-	-	72	18	35	28	35	38	-3.5	3	369.5				
	160	84	21	40	35	40	42	0.5	0	405.5	84	21	40	28	40	42	-4.5	5	405.5				
	180	3)	97	24	47	35	50	48	3.5	0	405.5	3)	97	24	47	28	50	48	-6.5	0	405.5		
	200	3)	112	27	54	35	60	55	-5.5	0	417.5	-	-	-	-	-	-	-	-				
	225	3)	127	27	59	35	65	60	-10	6.5	458.5	-	-	-	-	-	-	-	-				
114 / 124	160	-	-	-	-	-	-	-	-	-	84	21	40	32	40	42	13.5	0	447.5				
	180	97	24	50	45	50	48	10.5	0	473.5	97	24	50	32	50	48	16.5	0	447.5				
	200	112	27	60	45	60	55	1.5	0	485.5	112	27	60	32	60	55	7.5	0	459.5				
	225	127	27	65	45	65	60	16.5	0	500.5	127	27	65	32	65	60	0	3.5	500.5				
	250	127	27	65	45	65	65	16.5	0	500.5	-	-	-	-	-	-	-	-					
134 / 144	160	-	-	-	-	-	-	-	-	-	84	21	40	38	40	42	0	1.5	517.5				
	180	-	-	-	-	-	-	-	-	-	97	24	50	38	50	48	1.5	0	517.5				
	200	127	27	65	50	65	55	12.5	0	529.5	112	27	50	38	60	55	18.5	0	503.5				
	225	127	27	65	50	65	60	-3.5	4	579.5	127	27	61	38	65	60	7.5	0	544.5				
	250	127	27	65	50	65	65	-3.5	4	579.5	127	27	61	38	65	65	7.5	0	544.5				
	280	142	31	75	50	75	75	11	0	565	-	-	-	-	-	-	-	-					
	315 2)	162	36	75	50	80	80	9	0	602	-	-	-	-	-	-	-	-					
154 / 164	200	-	-	-	-	-	-	-	-	-	112	27	60	50	60	55	-3	3.5	598.5				
	225	127	27	65	60	65	60	-1.5	0	648.5	127	27	65	50	65	60	8.5	0	613.5				
	250	127	27	65	60	65	65	-1.5	0	648.5	127	27	65	50	65	65	8.5	0	613.5				
	280	142	31	75	60	75	75	17	0	634	142	31	75	50	75	75	-4	4	634				
	315 2)	162	36	80	60	80	80	15	0	671	162	36	80	50	80	80	-5	5	671				
174 / 184	225	-	-	-	-	-	-	-	-	-	127	27	65	50	65	60	3.5	0	623.5				
	250	-	-	-	-	-	-	-	-	-	127	27	65	50	65	65	3.5	0	623.5				
	280	142	31	75	60	75	75	12	0	644	142	31	75	50	75	75	-6.5	6.5	644				
	315 2)	162	36	80	60	80	80	10	0	681	162	36	80	50	80	80	-5	10	681				

TR

KAPLIN B
IEC BAĞLANTILI MOTORLAR

EN

MOTOR BELL HOUSING FOR
IEC STANDARD MOTORS WITH
B COUPLING

DE

MOTORKUPPLUNG FÜR IEC -
MOTOREN MIT B - KUPPLUNG

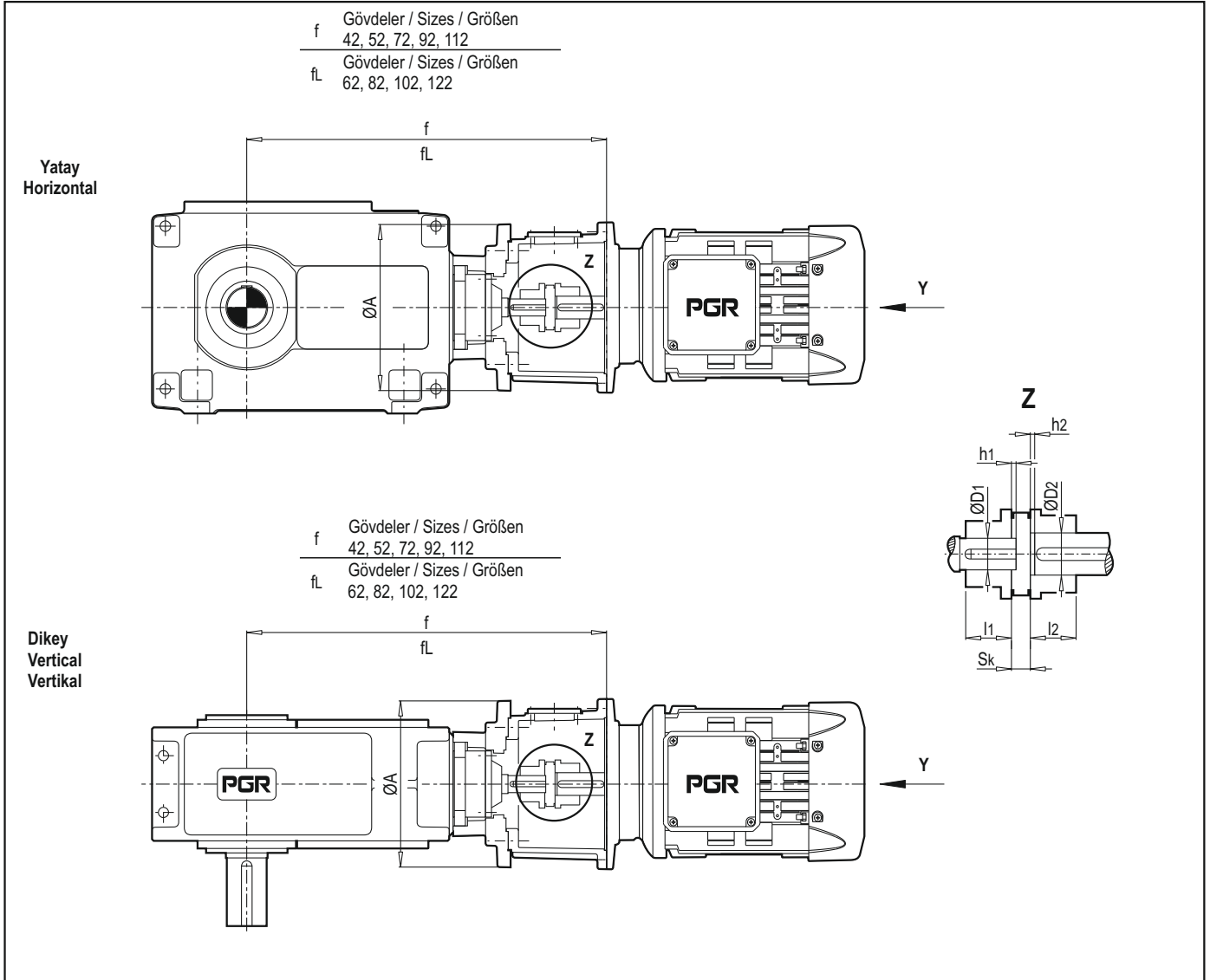

Özel tasarım gerektiren tesisler için (yüksek açma kapama frekansı ve değişken yük yönleri, örneğin kaldırma makinaları, hareketli taşıtlar ve benzeri), güncel ve geçerli kaplin katalogundan kontrol edilerek, uygun kaplin seçimi yapılır. Bunlardan farklı kaplin gerektiren durumlarda, mutlaka PGR ile görüşülmelidir!

DIN 42677 IEC-Standard motorlarının montaj ölçüleri (Y bakış açısı) için, sayfa 162'ye bakın. C,D,G,H,I modeli helisel dişli redüktörlerde, giriş milinde takonite E veya labirent keçe uygulaması yoktur, ancak talep üzerine uygulanır.

For plants with special design requirements (high switching frequency, alternating direction of load; e.g. hoisting gears, travelling gears, etc) the coupling design is to be checked in accordance with the respective valid coupling brochure. For other couplings, please consult PGR!

For fitting dimensions for IEC standard motors DIN 42677 (View Y), see page 162.
Helical gear unit in C, D, G, H, I, design on request only.
Not in connection with Taconite E or labyrinth seal on input shaft.

Bei Anlagen mit besonderen Auslegungsanforderungen (große Schalthäufigkeit, wechselnde Lastrichtung; z.B. Hubwerke, Fahrwerke, usw) ist die Auslegung der Kupplung nach dem jeweils gültigen Kupplungskatalog zu prüfen. Bei abweichenden Kupplungen ist Rücksprache mit PGR notwendig!

Anbaumaße für IEC-Normmotoren DIN 42677 (Ansicht Y) siehe Seite 162.
Stirnradgetriebe in Ausführung C, D, G, H, I nur auf Anfrage.
Nicht in Verbindung mit Taconite E oder Labyrinth-Abdichtung an der Antriebswelle

1) Diğer motor büyüklükleri, talep üzerine temin edilir.
2) Sadece 315S ve 315M motor büyüklükleri.

1) Other motor sizes on request
2) Sizes 315S and 315M only

1) andere Motorgrößen auf Anfrage
2) nur Baugröße 315S und 315M

TR

KAPLİN B
IEC BAĞLANTILI MOTORLAR

EN

MOTOR BELL HOUSING FOR
IEC STANDARD MOTORS WITH
B COUPLING

DE

MOTORKATERNE FÜR IEC -
MOTOREN MIT B - KUPPLUNG

Tablo 5 / Table 5 / Tabelle 5

Gövde Size Größe	Motor IEC 1)	Tahvil İN / Ratios İN / Übersetzungen İN 5 - 11.2 (Gövdeler / Sizes / Größen 42, 52,72,92,112) 6.3 - 14 (Gövdeler / Sizes / Größen 62, 82,102,122)											Tahvil İN / Ratios İN / Übersetzungen İN 12.5 - 18 (Gövdeler / Sizes / Größen 42, 52,72,92,112) 16 - 22.4 (Gövdeler / Sizes / Größen 62, 82,102,122)												
		Kaplin B B Coupling B Kupplung BWN	mm											Kaplin B B Coupling B Kupplung BWN	mm										
			sk	l1	ØD1	l2	ØD2	h1	h2	f	fL	ØA	sk		l1	ØD1	l2	ØD2	h1	h2	f	fL	ØA		
42	180	-	-	-	-	-	-	-	-	-	-	-	97	24	50	35	50	48	0.5	0	678.5	-	350		
	200	112	27	60	45	60	55	17.5	0	684.5	-	350	112	27	60	35	60	55	-2.5	0	684.5	-	350		
52 / 62	200	-	-	-	-	-	-	-	-	-	-	-	112	27	60	40	60	55	-8.5	0	763.5	798.5	350		
	225	-	-	-	-	-	-	-	-	-	-	-	127	27	65	40	65	60	-2.5	0	804.5	839.5	350		
72 / 82	250	-	-	-	-	-	-	-	-	-	-	-	127	27	65	50	65	65	2	0	915	960	440		
	280	162	36	80	70	80	75	17	0	934	979	440	142	31	75	50	75	75	-6.5	6.5	934	979	440		
92 / 102	280	-	-	-	-	-	-	-	-	-	-	-	142	31	75	60	75	75	-4	4	1074	1124	445		
112 / 122	315 2)	-	-	-	-	-	-	-	-	-	-	-	162	36	80	70	80	80	15	0	1256	1326	520		
132 / 142	355 MB 9)												202	48	100	80	100	90	1	0	1457	1527	650		
	355 LB 9)												227	54	110	80	110	90	7	0	1457	1527	650		

TR

KAPLIN B
IEC BAĞLANTILI MOTORLAR

EN

MOTOR BELL HOUSING FOR
IEC STANDARD MOTORS WITH
B COUPLING

DE

MOTORKATERNE FÜR IEC -
MOTOREN MIT B - KUPPLUNG

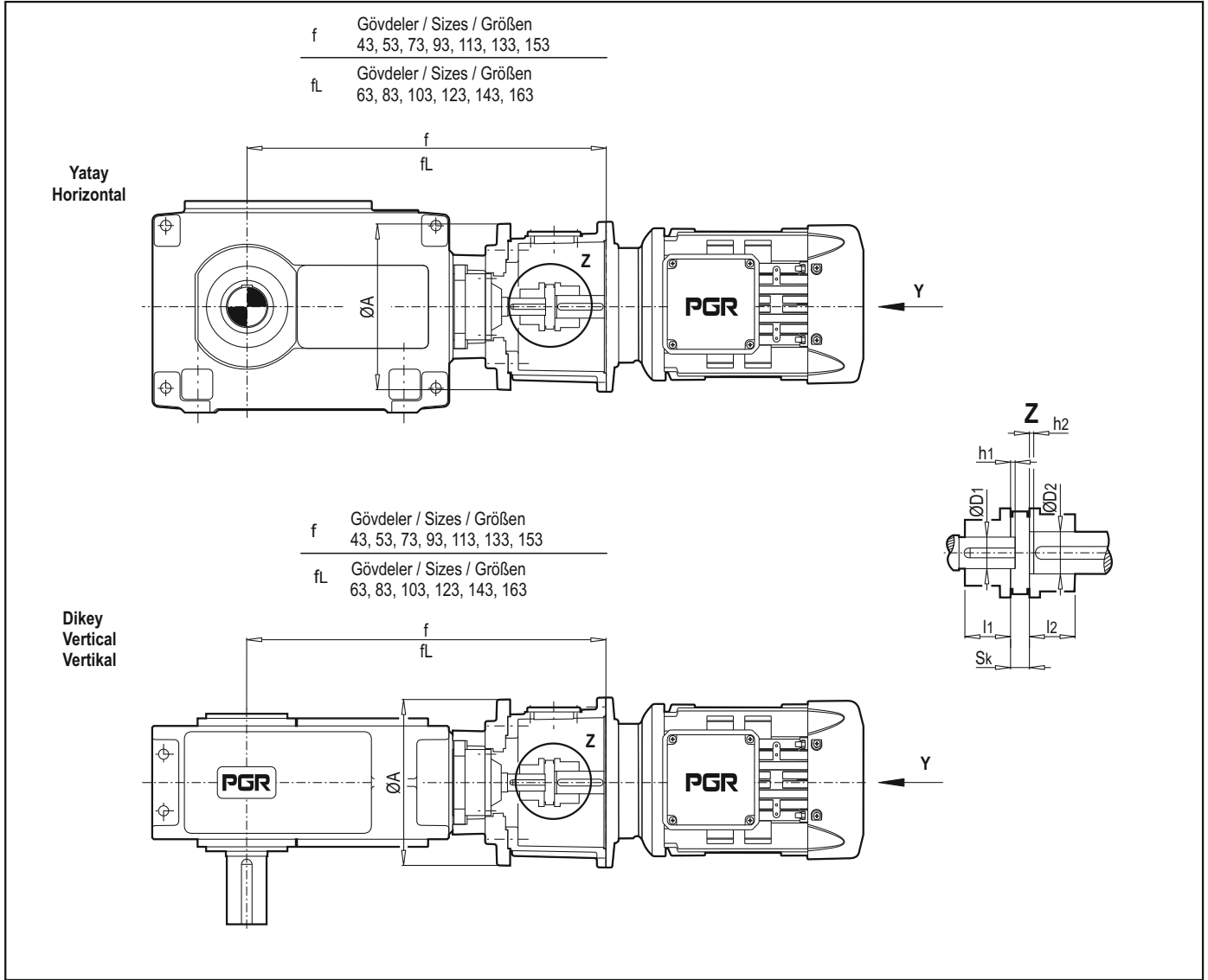

Özel tasarım gerektiren tesisler için (yüksek açma kapama frekansı ve değişken yük yönleri örneğin kaldırma makinaları, hareketli taşıtlar ve benzeri), güncel ve geçerli kaplin kataloğundan kontrol edilerek, uygun kaplin seçimi yapılır. Bunlardan farklı kaplin gerektiren durumlarda, mutlaka PGR ile görüşülmelidir!
DIN 42677 IEC- Standart motorlarının montaj ölçüleri (Y bakış açısı) için, sayfa 162'ye bakın. C,D,G,H,I modeli helisel dişli redüktörlerde, giriş milinde takonite E veya labirent keçe uygulaması yoktur, ancak talep üzerine uygulanır.

For plants with special design requirements (high switching frequency, alternating direction of load; e.g hoisting gears, travelling gears, etc) the coupling design is to be checked in accordance with the respective valid coupling brochure. For other couplings, please consult PGR!
For fitting dimensions for IEC standard motors DIN 42677 (View Y), see page 162. Helical gear unit in C, D, G, H, I, design on request only. Not in connection with Taconite E or labyrinth seal on input shaft.

Bei Anlagen mit besonderen Auslegungsanforderungen (große Schalthäufigkeit, wechselnde Lastrichtung; z.B. Hubwerke, Fahrwerke, usw) ist die Auslegung der Kupplung nach dem jeweils gültigen Kupplungskatalog zu prüfen. Bei abweichenden Kupplungen ist Rücksprache mit PGR notwendig! Anbaumaße für IEC- Normmotoren DIN 42677 (Ansicht Y) siehe Seite 162. Stinradgetriebe in Ausführung C, D, G, H, I nur auf Anfrage. Nicht in Verbindung mit Taconite E oder Labyrinth - Abdichtung an der Antriebswelle

- 1) Diğer motor büyüklükleri, talep üzerine temin edilir.
- 2) Sadece 315S ve 315M motor büyüklükleri.
- 3) Redüktör miline oturan kaplin göbeğinin l1 uzunluğu kısaltılmıştır.

- 1) Other motor sizes on request
- 2) Sizes 315S and 315M only
- 3) Length l1 of coupling hub Shortened for fitting onto gear unit shaft.

- 1) andere Motorgrößen auf Anfrage
- 2) nur Baugröße 315S und 315M
- 3) Länge l1 der Kupplungsnabe zum Aufsetzen Auf Getriebewelle gekürzt.

TR KAPLİN B
IEC BAĞLANTILI MOTORLAR

EN MOTOR BELL HOUSING FOR
IEC STANDARD MOTORS WITH
B COUPLING

DE MOTORLATERNE FÜR IEC -
MOTOREN MIT B - KUPPLUNG

Tablo 6 / Table 6 / Tabelle 6																															
Gövde Size Größe	Motor IEC	Tahviller İN / Ratios İN / Übersetzungen İN 12,5 - 45 (Gövdeler / Sizes / Größen 43, 53, 73,93,113) 16 - 56 (Gövdeler / Sizes / Größen 63, 83,103,123) 12,5 - 45 (Gövdeler / Sizes / Größen 133,153) 16 - 56 (Gövde / Size / Größe 143) 14 - 50 (Gövde / Size / Größe 163)											Tahviller İN / Ratios İN / Übersetzungen İN 50 - 71 (Gövdeler / Sizes / Größen 43, 53, 73,93,113) 63 - 90 (Gövdeler / Sizes / Größen 63, 83,103,123) 50 - 71 (Gövdeler / Sizes / Größen 133,153) 63 - 90 (Gövde / Size / Größe 143) 56 - 80 (Gövde / Size / Größe 163)																		
		Kaplin B B Coupling B Kupplung BWN	mm											Kaplin B B Coupling B Kupplung BWN	mm																
			Sk	l1	ØD1	l2	ØD2	h1	h2	f	fL	ØA	Sk		l1	ØD1	l2	ØD2	h1	h2	f	fL	ØA								
43	132	-	-	-	-	-	-	-	-	-	-	-	-	-	-	-	-	-	-	-	72	18	35	25	35	38	10.5	0	646.5	-	250
	160	84	21	40	30	40	42	-3.5	4	708.5	-	250	84	21	40	25	40	42	8.5	0	682.5	-	250								
	180	97	24	50	30	50	48	-2.5	2	708.5	-	250	97	24	40	25	50	48	11.5	0	682.5	-	250								
	200	3)	112	27	55	30	60	55	12.5	0	694.5	-	250	-	-	-	-	-	-	-	-	-	-	-	-	-	-	-	-	-	-
53 / 63	160	84	21	40	35	40	42	14.5	0	771.5	806.5	350	84	21	40	28	40	42	-2.5	3	771.5	806.5	350								
	180	97	24	50	35	50	48	17.5	0	771.5	806.5	350	97	24	50	28	50	48	0	2.5	771.5	806.5	350								
	200	112	27	60	35	60	55	8.5	0	782.5	818.5	350	112	27	60	28	60	55	-5.5	6	782.5	818.5	350								
	225	127	27	65	35	65	60	0	2.5	824.5	859.5	350	-	-	-	-	-	-	-	-	-	-	-								
73 / 83	160	-	-	-	-	-	-	-	-	-	-	-	84	21	40	35	40	42	0	2.5	903.5	948.5	440								
	180	-	-	-	-	-	-	-	-	-	-	-	97	24	50	35	50	48	0.5	0	903.5	948.5	440								
	200	112	27	60	45	60	55	17.5	0	909.5	954.5	440	112	27	60	35	60	55	0	2.5	909.5	945.5	440								
	225	127	27	65	45	65	60	6.5	0	950.5	995.5	440	127	27	65	35	65	60	1.5	0	935.5	980.5	440								
	250	127	27	65	45	65	65	5	0	952	997	440	127	27	65	35	65	65	1.5	0	935.5	980.5	440								
	280	142	31	75	45	75	75	-5	5	971	1016	440	-	-	-	-	-	-	-	-	-	-	-								
93 / 103	200	-	-	-	-	-	-	-	-	-	-	-	112	27	60	40	60	55	2.5	0	1034.5	1084.5	440								
	225	127	27	65	55	65	60	1.5	0	1075.5	1125.5	440	127	27	65	40	65	60	-4	4.5	1075.5	1125.5	440								
	250	127	27	65	55	65	65	0	0	1077	1127	440	127	27	65	40	65	65	-5	5	1077	1127	440								
	280	142	31	75	55	75	75	-7.5	7.5	1096	1146	440	142	31	75	40	75	75	2.5	2.5	1076	1126	440								
113 / 123	225	-	-	-	-	-	-	-	-	-	-	-	127	27	65	50	65	60	-3	3.5	1243.5	1313.5	440								
	250	142	31	75	70	75	65	6	0	1260	1330	440	127	27	65	50	65	65	-3	3.5	1243.5	1313.5	440								
	280	142	31	75	70	75	75	-6.5	6.5	1279	1349	440	142	31	75	50	75	75	12	0	1229	1299	440								
	315	2)	162	36	80	70	80	80	-7.5	7.5	1316	1386	440	162	36	80	50	80	80	10	0	1266	1336	440							
133 / 143	280	-	-	-	-	-	-	-	-	-	-	-	142	31	75	60	75	75	12	0	1424	1494	650								
	315	2)	182	42	90	80	90	80	-5	4	1511	1581	445	162	36	80	60	80	80	10	0	1461	1531	650							
153 / 163	315	2)	-	-	-	-	-	-	-	-	-	-	162	36	80	70	80	80	13	0	1700	1746	650								

TR

KAPLİN B
IEC BAĞLANTILI MOTORLAR

EN

MOTOR BELL HOUSING FOR
IEC STANDARD MOTORS WITH
B COUPLING

DE

MOTORKATERNE FÜR IEC -
MOTOREN MIT B - KUPPLUNG

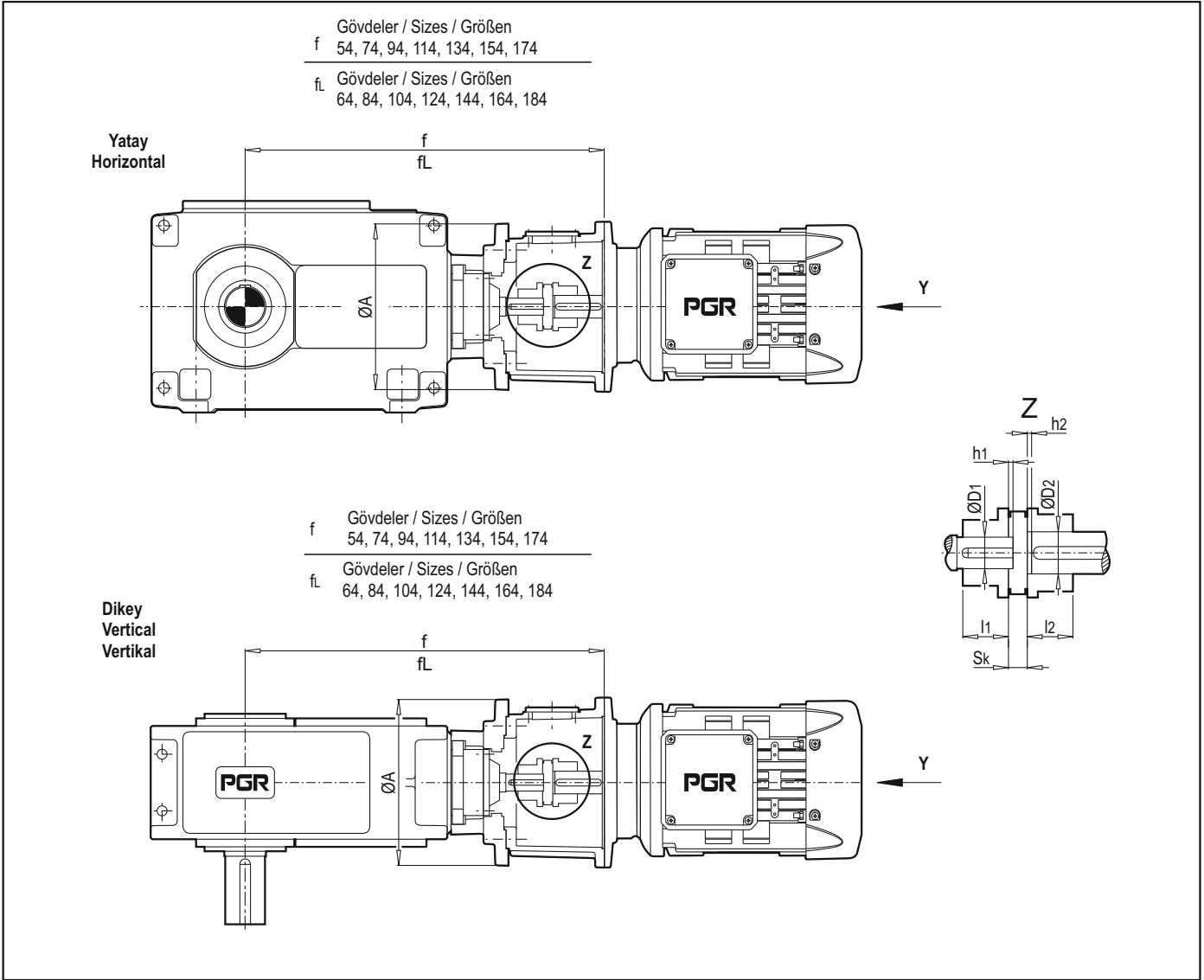

Özel tasarım gerektiren tesisler için (yüksek açma kapama frekansı ve değişken yük yönleri örneğin kaldırma makinaları, hareketli taşıtlar ve benzeri), güncel ve geçerli kaplin kataloğundan kontrol edilerek, uygun kaplin seçimi yapılır. Bunlardan farklı kaplin gerektiren durumlarda, mutlaka PGR ile görüşülmelidir!

DIN 42677 IEC-Standart motorlarının montaj ölçüleri (Y bakış açısı) için, sayfa 162'ye bakın. C,D,G,H,I modeli helisel dişli redüktörlerde, giriş milinde takonite E veya labirent keçe uygulaması yoktur, ancak talep üzerine uygulanır.

For plants with special design requirements (high switching frequency, alternating direction of load; e.g hoisting gears, travelling gears, etc) the coupling design is to be checked in accordance with the respective valid coupling brochure. For other couplings, please consult PGR!

For fitting dimensions for IEC standard motors DIN 42677 (View Y), see page 162. Helical gear unit in C, D, G, H, I, design on request only. Not in connection with Taconite E or labyrinth seal on input shaft.

Bei Anlagen mit besonderen Auslegungsanforderungen (große Schalthäufigkeit, wechselnde Lastrichtung; z.B. Hubwerke, Fahrwerke, usw) ist die Auslegung der Kupplung nach dem jeweils gültigen Kupplungskatalog zu prüfen. Bei abweichenden Kupplungen ist Rücksprache mit PGR notwendig!

Anbaumaße für IEC-Normmotoren DIN 42677 (Ansicht Y) siehe Seite 162. Stinradgetriebe in Ausführung C, D, G, H, I nur auf Anfrage. Nicht in Verbindung mit Taconite E oder Labyrinth - Abdichtung an der Antriebswelle

- 1) Diğer motor büyüklükleri, talep üzerine temin edilir.
- 2) Sadece 315S ve 315M motor büyüklükleri.
- 3) Redüktör miline oturan kaplin göbeğinin l1 uzunluğu kısaltılmıştır.

- 1) Other motor sizes on request
- 2) Sizes 315S and 315M only
- 3) Length l1 of coupling hub Shortened for fitting onto gear unit shaft.

- 1) andere Motorgößen auf Anfrage
- 2) nur Baugröße 315S und 315M
- 3) Länge l1 der Kupplungsnahe zum Aufsetzen Auf Getriebewelle Gekürzt.

TR KAPLIN B
IEC BAĞLANTILI MOTORLAR

EN MOTOR BELL HOUSING FOR
IEC STANDARD MOTORS WITH
B COUPLING

DE MOTORLATERNE FÜR IEC -
MOTOREN MIT B - KUPPLUNG

Tablo 7 / Table 7 / Tabelle 7																								
Gövde Size Größe	Motor IEC	Tahviller İN / Ratios İN / Übersetzungen İN											Tahviller İN / Ratios İN / Übersetzungen İN											
		80 - 180 (Gövdeler / Sizes / Größen 54, 74,94,114) 100 - 224 (Gövdeler / Sizes / Größen 64, 84,104,124) 80 - 180 (Gövdeler / Sizes / Größen 134,154,174) 100 - 224 (Gövde / Size / Größe 144) 90 - 200 (Gövdeler / Sizes / Größen 164,184)											200 - 315 (Gövdeler / Sizes / Größen 54, 74,94,114) 250 - 400 (Gövdeler / Sizes / Größen 64, 84,104,124) 200 - 315 (Gövdeler / Sizes / Größen 134,154,174) 250 - 400 (Gövde / Size / Größe 144) 224 - 355 (Gövdeler / Sizes / Größen 164,184)											
		Kaplin B B Coupling B Kupplung BWN	mm										Kaplin B B Coupling B Kupplung BWN	mm										
sk	l1	ØD1	l2	ØD2	h1	h2	f	fL	ØA	sk	l1	ØD1	l2	ØD2	h1	h2	f	fL	ØA					
54 / 64	100	-	-	-	-	-	-	-	-	-	-	-	-	-	-	-	-	-	-	-				
	112	62	16	30	28	30	28	2	2	750	785	250	62	16	30	20	30	28	6	0	735	770	250	
	132	72	18	35	28	35	38	0.5	0	767.5	802.5	250	72	18	35	20	35	38	-2.5	2	767.5	802.5	250	
	160	84	21	40	28	40	42	-1.5	0	802.5	837.5	250	-	-	-	-	-	-	-	-	-	-	-	
74 / 84	112	-	-	-	-	-	-	-	-	-	-	-	62	16	30	25	30	28	6	0	855	900	250	
	132	72	18	35	30	35	38	5.5	0	887.5	932.5	250	72	18	35	25	35	38	10.5	0	872.5	917.5	250	
	160	84	21	40	30	40	42	-3.5	4	933.5	978.5	250	84	21	40	25	40	42	8.5	0	907.5	952.5	250	
	180	97	24	50	30	50	48	-2	2.5	933.5	978.5	250	-	-	-	-	-	-	-	-	-	-	-	
	200	3)	112	27	55	30	60	55	12.5	0	919.5	964.5	250	-	-	-	-	-	-	-	-	-	-	-
94 / 104	132	-	-	-	-	-	-	-	-	-	-	-	72	18	35	28	35	38	-1.5	2	1001.5	1051.5	350	
	160	84	21	40	35	40	42	14.5	0	1036.5	1086.5	350	84	21	40	28	40	42	-2.5	3	1036.5	1086.5	350	
	180	97	24	50	35	50	48	17.5	0	1036.5	1086.5	350	97	24	50	28	50	48	0	2.5	1036.5	1086.5	350	
	200	112	27	60	35	60	55	8.5	0	1048.5	1098.5	350	-	-	-	-	-	-	-	-	-	-	-	-
	225	127	27	65	35	65	60	0	2.5	1089.5	1139.5	350	-	-	-	-	-	-	-	-	-	-	-	-
114 / 124	160	-	-	-	-	-	-	-	-	-	-	-	84	21	40	35	40	42	0	2.5	1223.5	1293.5	440	
	180	97	24	50	45	50	48	-2.5	3	1249.5	1319.5	440	97	24	50	35	50	48	0.5	0	1223.5	1293.5	440	
	200	112	27	60	45	60	55	17.5	0	1229.5	1299.5	440	112	27	60	35	60	55	-2.5	0	1229.5	1299.5	440	
	225	127	27	65	45	65	60	6.5	0	1270.5	1340.5	440	127	27	65	35	65	60	-6.5	7	1270.5	1340.5	440	
	250	127	27	65	45	65	65	5	0	1272	1342	440	-	-	-	-	-	-	-	-	-	-	-	-
	280	142	31	75	45	75	75	-5	5	1291	1361	440	-	-	-	-	-	-	-	-	-	-	-	-
134 / 144	180	-	-	-	-	-	-	-	-	-	-	-	97	24	50	40	50	48	5.5	0	1398.5	1468.5	440	
	200	112	27	60	55	60	55	12.5	0	1404.5	1474.5	440	112	27	60	40	60	55	2.5	0	1404.5	1474.5	440	
	225	127	27	65	55	65	60	1.5	0	1445.5	1515.5	440	127	27	65	40	65	60	-4	4.5	1445.5	1515.5	440	
	250	127	27	65	55	65	65	0	0	1447	1517	440	127	27	65	40	65	65	-5	5	1447	1517	440	
	280	142	31	75	55	75	75	5	0	1446	1516	440	142	31	75	40	75	75	-2.5	2.5	1446	1516	440	
	315 2)	162	36	80	55	80	80	3	0	1483	1553	440	-	-	-	-	-	-	-	-	-	-	-	-
154 / 164	200	-	-	-	-	-	-	-	-	-	-	-	112	27	60	50	60	55	-5	5.5	1659.5	1705.5	440	
	225	142	31	75	70	75	60	4.5	-3	1700.5	1746.5	440	127	27	65	50	65	60	-3	3.5	1685.5	1731.5	440	
	250	142	31	75	70	75	65	6	0	1702	1748	440	127	27	65	50	65	65	-3	3.5	1685.5	1731.5	440	
	280	142	31	75	70	75	75	-6.5	6.5	1721	1767	440	142	31	75	50	75	75	12	0	1671	1717	440	
	315 2)	162	36	80	70	80	80	5	0	1738	1784	440	162	36	80	50	80	80	10	0	1708	1754	440	
174 / 184	225	-	-	-	-	-	-	-	-	-	-	-	127	27	65	50	65	60	-3	-3.5	1733.5	1793.5	440	
	250	-	-	-	-	-	-	-	-	-	-	-	127	27	65	50	65	65	-3	-3.5	1733.5	1793.5	440	
	280	142	31	75	70	75	75	-6.5	6.5	1769	1829	440	142	31	75	50	75	75	12	0	1718.5	1778.5	440	
	315 2)	182	42	90	70	90	80	-4.5	4.5	1806	1866	440	162	36	80	50	80	80	10	0	1756	1816	440	

TR

KAPLİN N
IEC BAĞLANTILI MOTORLAR

EN

MOTOR BELL HOUSING FOR
IEC STANDARD MOTORS WITH
N COUPLING

DE

MOTORLATERNE FÜR IEC - MOTOREN
MIT N - KUPPLUNG

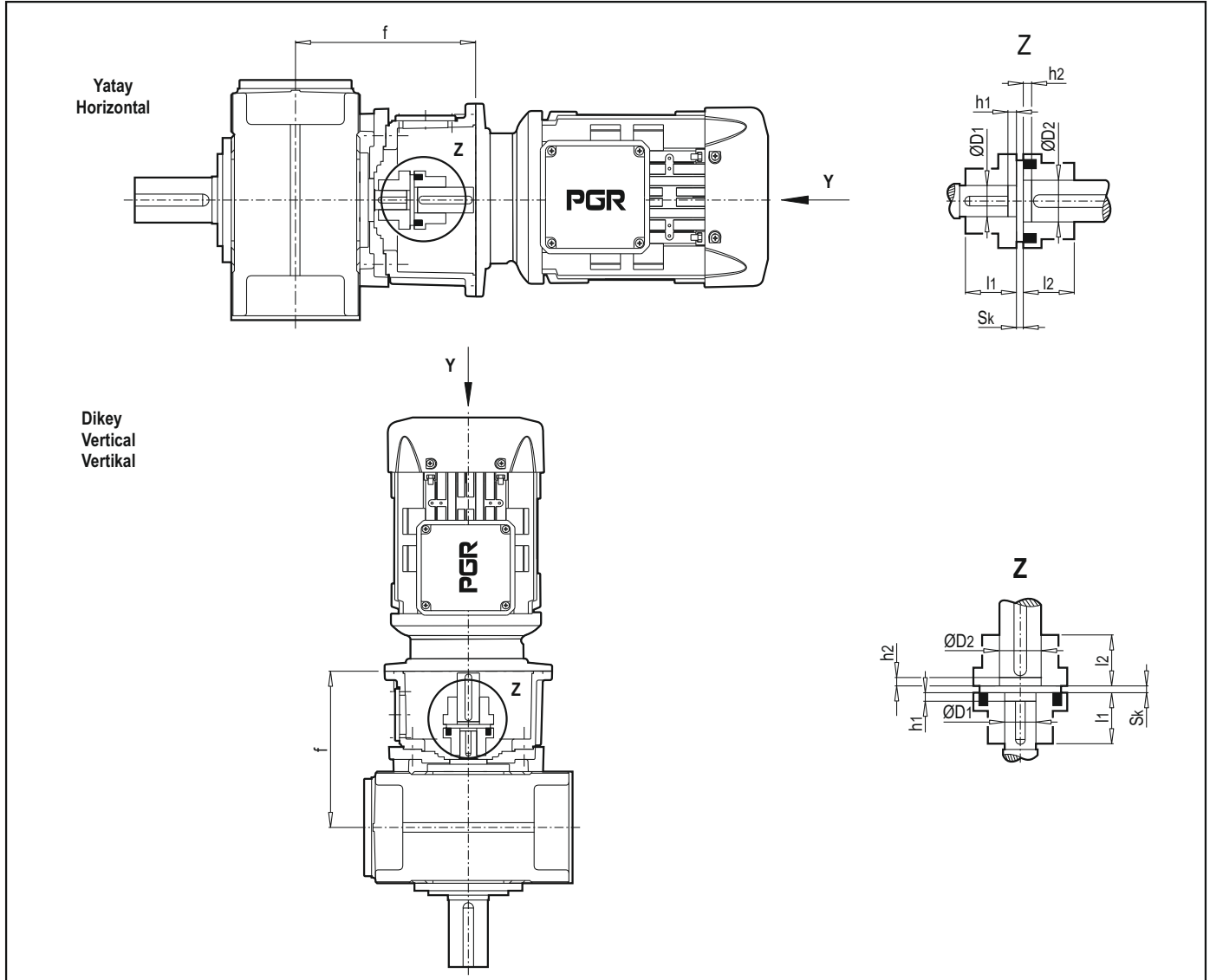

Özel tasarım gerektiren tesisler için (yüksek açma kapama frekansı ve değişken yük yönleri, örneğin kaldırma makinaları, hareketli taşıtlar ve benzeri), güncel ve geçerli kaplin kataloğundan kontrol edilerek, uygun kaplin seçimi yapılır. Bunlardan farklı kaplin gerektiren durumlarda, mutlaka PGR ile görüşülmelidir!
DIN 42677 IEC-Standart motorlarının montaj ölçüleri (Y bakış açısı) için, sayfa 162'ye bakın. C,D,G,H,I modeli helisel dişli redüktörlerde, giriş milinde takonite E veya labirent keçe uygulaması yoktur, ancak talep üzerine uygulanır.

For plants with special design requirements (high switching frequency, alternating direction of load; e.g hoisting gears, travelling gears, etc) the coupling design is to be checked in accordance with the respective valid coupling brochure. For other couplings, please consult PGR!
For fitting dimensions for IEC standard motors DIN 42677 (View Y), see page 162. Helical gear unit in C, D, G, H, I, design on request only. Not in connection with Taconite E or labyrinth seal on input shaft.

Bei Anlagen mit besonderen Auslegungsanforderungen (große Schalthäufigkeit, wechselnde Lastrichtung; z.B. Hubwerke, Fahrwerke, usw) ist die Auslegung der Kupplung nach dem jeweils gültigen Kupplungskatalog zu prüfen. Bei abweichenden Kupplungen ist Rücksprache mit PGR notwendig!
Anbaumaße für IEC-Normmotoren DIN 42677 (Ansicht Y) siehe Seite 162. Stinradgetriebe in Ausführung C, D, G, H, I nur auf Anfrage. Nicht in Verbindung mit Taconite E oder Labyrinth -Abdichtung an der Antriebswelle

- 1) Diğer motor büyüklükleri, talep üzerine temin edilir.
- 2) Sadece 315S ve 315M tipi imalat büyüklükleri.
- 4) Sadece dikey redüktörler için.
- 5) PH...2-D imalat modellerinin A+B uygulama tiplerine montajı mümkün değildir.
- 6) PH...2-D imalat modellerinin 5 gövde büyüklüğünün A+B uygulama tiplerine montajı mümkün değildir.
- 7) PH...2-D imalat modellerinin 7 gövde büyüklüğünün A+B uygulama tiplerine montajı mümkün değildir.
- 8) PH...2-DV imalat modellerinin 9 gövde büyüklüğünün A+B uygulama tiplerine montajı mümkün değildir.

- 1) Other motor sizes on request
- 2) Sizes 315S and 315M only
- 4) For vertical gear units only
- 5) For type PH...2-D design A+B; fitting not possible.
- 6) For type PH...2-D size 5 design A+B; fitting not possible.
- 7) For type PH...2-D size 7 design A+B; fitting not possible.
- 8) For type PH...2-DV size 9 design A+B; fitting not possible.

- 1) andere Motorgößen auf Anfrage
- 2) nur Baugröße 315S und 315M
- 4) nur für Vertikalgetriebe
- 5) Bei Bauart PH...2-D Ausführung A+B; Anbau nicht möglich.
- 6) Bei Bauart PH...2-D Größe 5 Ausführung A+B; Anbau nicht möglich.
- 7) Bei Bauart PH...2-D Größe 7 Ausführung A+B; Anbau nicht möglich.
- 8) Bei Bauart PH...2-DV Größe 9 Ausführung A+B; Anbau nicht möglich.

TR

KAPLIN N
IEC BAĞLANTILI MOTORLAR

EN

MOTOR BELL HOUSING FOR
IEC STANDARD MOTORS WITH
N COUPLING

DE

MOTORLATERNE FÜR IEC - MOTOREN
MIT N - KUPPLUNG

Tablo 8 / Table 8 / Tabelle 8																							
Gövde Size Größe	Motor IEC ¹⁾	Tahviller İN / Ratios İN / Übersetzungen İN 6.3 - 11..2 (Gövdeler / Sizes / Größen 42,52,72,92,112) 8 - 14 (Gövdeler / Sizes / Größen 62, 82,102,122)										Tahviller İN / Ratios İN / Übersetzungen İN 12.5 - 22.4 (Gövdeler / Sizes / Größen 42, 52, 72,92,112) 16 - 28 (Gövdeler / Sizes / Größen 62, 82,102,122)											
		Kaplin N N Coupling N Kupplung	mm										Kaplin N N Coupling N Kupplung	mm									
			sk	l1	ØD1	l2	ØD2	h1	h2	f	sk	l1		ØD1	l2	ØD2	h1	h2	f				
42	160 ⁵⁾	-	-	-	-	-	-	-	-	-	-	A125	3	50	32	50	42	0	7	370			
	180 ⁵⁾	-	-	-	-	-	-	-	-	-	-	A140	3	55	32	55	48	0	7	370			
	200 ⁵⁾	-	-	-	-	-	-	-	-	-	-	A160	4	60	32	60	55	0	12	376			
	225 ⁵⁾	4)	A180	4	70	45	70	60	0	3	417	4)	A180	4	70	32	70	60	0	8	402		
52 / 62	200	-	-	-	-	-	-	-	-	-	-	A160	4	60	38	60	55	0	13	402			
	225 ⁶⁾	-	-	-	-	-	-	-	-	-	-	-	-	-	-	-	-	-	-	-			
	250 ⁵⁾	4)	A180	4	70	50	70	65	0	5.5	444.5	4)	A180	4	70	38	70	65	0	9	428		
72 / 82	225	-	-	-	-	-	-	-	-	-	-	A180	4	70	50	70	60	0	9.5	473.5			
	250 ⁷⁾	-	-	-	-	-	-	-	-	-	-	A180	4	70	50	70	65	0	11	475			
	280 ⁷⁾	-	-	-	-	-	-	-	-	-	-	A200	4	80	50	80	75	0	10	474			
	315 ^{2) 5)}	4)	A225	4	90	60	90	80	0	12	531	4)	A250	5.5	100	50	100	80	0	15.5	511		
92 / 102	280	-	-	-	-	-	-	-	-	-	-	A200	4	80	60	80	75	0	5	530			
	315 ^{2) 8)}	4)	A225	4	90	75	90	80	3	9	566	4)	A225	4	90	60	90	80	0	12	566		
112 / 122	315 ²⁾	-	-	-	-	-	-	-	-	-	-	A225	4	90	70	90	80	0	17	606			

TR

KAPLİN N
IEC BAĞLANTILI MOTORLAR

EN

MOTOR BELL HOUSING FOR
IEC STANDARD MOTORS WITH
N COUPLING

DE

MOTORLATERNE FÜR IEC - MOTOREN
MIT N - KUPPLUNG

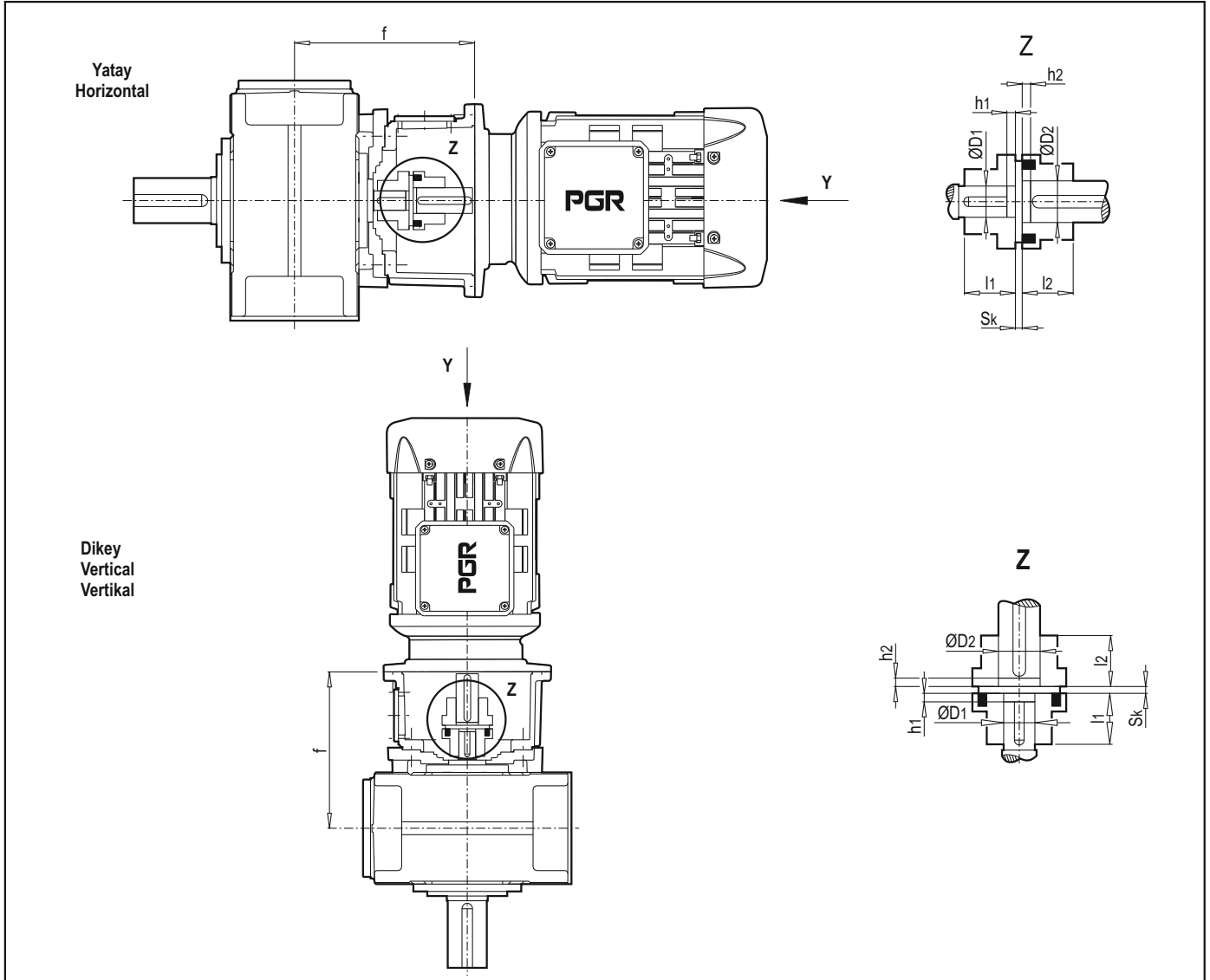

Özel tasarım gerektiren tesisler için (yüksek açma kapama frekansı ve değişken yük istikametleri, örneğin kaldırma makineleri, hareketli taşıtlar ve benzeri), güncel ve geçerli kaplin katalogundan kontrol edilerek, uygun kaplin seçimi yapılır. Bunlardan farklı kaplin gerektiren durumlarda, mutlaka PGR ile görüşülmelidir!

DIN 42677 IEC-Standard motorlarının montaj ölçüleri (Y bakış açısı) için, sayfa 162'ye bakın. G, H ve I modeli helisel dişli redüktörlerde, giriş milinde takonite E veya labirent keçe uygulaması yoktur, ancak talep üzerine uygulanır.

For plants with special design requirements (high switching frequency, alternating direction of load; e.g. hoisting gears, travelling gears, etc) the coupling design is to be checked in accordance with the respective valid coupling brochure. For other couplings, please consult PGR!

For fitting dimensions for IEC standard motors DIN 42677 (View Y), see page 162. Helical gear unit in G, H, I, design on request only. Not in connection with Taconite E or labyrinth seal on input shaft.

Bei Anlagen mit besonderen Auslegungsanforderungen (große Schaltfrequenz, wechselnde Lastrichtung; z.B. Hubwerke, Fahrwerke, usw.) ist die Auslegung der Kupplung nach dem jeweils gültigen Kupplungskatalog zu prüfen. Bei abweichenden Kupplungen ist Rücksprache mit PGR notwendig!

Anbaumaße für IEC-Normmotoren DIN 42677 (Ansicht Y) siehe Seite 162. Stinradgetriebe in Ausführung G, H, I nur auf Anfrage. Nicht in Verbindung mit Taconite E oder Labyrinth- Abdichtung an der Antriebswelle

- 1) Diğer motor büyüklükleri, talep üzerine temin edilir.
- 2) Sadece 315S ve 315M motor büyüklükleri.
- 4) Sadece dikey redüktörler için.

- 1) Other motor sizes on request
- 2) Sizes 315S and 315M only
- 4) For vertical gear units only

- 1) andere Motorgößen auf Anfrage
- 2) nur Baugröße 315S und 315M
- 4) nur für Vertikalgetriebe

TR KAPLIN N
IEC BAĞLANTILI MOTORLAR

EN MOTOR BELL HOUSING FOR
IEC STANDARD MOTORS WITH
N COUPLING

DE MOTORLATERNE FÜR IEC - MOTOREN
MIT N - KUPPLUNG

Tablo 9 / Table 9 / Tabelle 9																												
Gövde Size Größe	Motor 1) Moteur IEC	Tahviller İN / Ratios İN / Übersetzungen İN 25 - 45 (Gövdeler/Sizes/Größen 53,73,93,113) 31.5 - 56 (Gövdeler/Sizes/Größen 63,83,103,123) 22.4 - 45 (Gövdeler/Sizes/Größen 133,153,173) 28 - 56 (Gövde/Size/Größe 143) 25 - 50 (Gövdeler/Sizes/Größen 163,183)									Tahviller İN / Ratios İN / Übersetzungen İN 50 - 63 (Gövdeler/Sizes/Größen 53,73,93,113) 63 - 80 (Gövdeler/Sizes/Größen 63,83,103,123) 50 - 63 (Gövdeler/Sizes/Größen 133,153,17) 63 - 80 (Gövde/Size/Größe 143) 56 - 71 (Gövdeler/Sizes/Größen 163,183)									Tahviller İN / Ratios İN / Übersetzungen İN 71 - 90 (Gövdeler/Sizes/Größen 53,73,93,113) 90 - 112 (Gövdeler/Sizes/Größen 63,83,103,123) 71 - 90 (Gövdeler/Sizes/Größen 133,153,173) 90 - 112 (Gövde/Size/Größe 143) 80 - 100 (Gövdeler/Sizes/Größen 163,183)								
		Kaplin N N Coupling N Kupplung	sk	l1	ØD1	l2	ØD2	h1	h2	f	Kaplin N N Coupling N Kupplung	sk	l1	ØD1	l2	ØD2	h1	h2	f	Kaplin N N Coupling N Kupplung	sk	l1	ØD1	l2	ØD2	h1	h2	f
53 / 63	132	-	-	-	-	-	-	-	-	-	-	-	-	-	-	-	-	-	B95	3	35	24	35	38	7	12	302	
	160	A125	3	50	40	50	42	12	9	364	A125	3	50	30	50	42	7	8	338	A125	3	50	24	50	42	17	8	338
	180	A140	3	55	40	55	48	6.5	14.5	364	A140	3	55	30	55	48	5	10	338	A140	3	55	24	55	48	15	10	338
	200	A160	4	60	40	60	55	0	6	350	A160	4	60	30	60	55	17	9	350	-	-	-	-	-	-	-	-	-
	225	A180	4	70	40	70	60	10	7	391	-	-	-	-	-	-	-	-	-	-	-	-	-	-	-	-	-	
	250	4) A180	4	70	40	70	65	11.5	5	391	-	-	-	-	-	-	-	-	-	-	-	-	-	-	-	-	-	
73 / 83	160	-	-	-	-	-	-	-	-	-	-	-	-	-	-	-	-	-	A125	3	50	28	50	42	7	12	367	
	180	-	-	-	-	-	-	-	-	A140	3	55	35	55	48	0	9	367	A140	3	55	28	55	48	10	9	367	
	200	A160	4	60	45	60	55	0	0	379	A160	4	60	35	60	55	9	12	379	A160	4	60	28	60	55	17	13	379
	225	A180	4	70	45	70	60	0	11	420	A180	4	70	35	70	60	18	12.5	420	-	-	-	-	-	-	-	-	-
	250	A180	4	70	45	70	65	0	11	420	A180	4	70	35	70	65	15	16	420	-	-	-	-	-	-	-	-	-
	280	A200	4	80	45	80	75	14.5	17	440.5	-	-	-	-	-	-	-	-	-	-	-	-	-	-	-	-	-	
93 / 103	180	-	-	-	-	-	-	-	-	-	-	-	-	-	-	-	-	-	A140	3	55	32	55	48	0	8.5	431.5	
	200	-	-	-	-	-	-	-	-	-	-	-	-	-	-	-	-	-	A160	4	60	32	60	55	0	19.5	443.5	
	225	A180	4	70	60	70	60	13.5	7	519.5	A180	4	70	45	70	60	0	10.5	484.5	A180	4	70	32	70	60	9	21.5	484.5
	250	A180	4	70	60	70	65	11.5	9	519.5	A180	4	70	45	70	65	0	10.5	484.5	A180	4	70	32	70	65	5.5	25	484.5
	280	A200	4	80	60	80	75	0	6	505	A200	4	80	45	80	75	5	26	505	-	-	-	-	-	-	-	-	-
	315 2)	4) A225	4	90	60	90	80	0	13	542	4) A225	4	90	45	90	80	12	26	542	-	-	-	-	-	-	-	-	-
113 / 123	225	-	-	-	-	-	-	-	-	-	-	-	-	-	-	-	-	-	A180	4	70	42	70	60	9.5	11	489.5	
	250	-	-	-	-	-	-	-	-	A180	4	70	65	70	65	0	10.5	489.5	A180	4	70	42	70	65	9.5	11	489.5	
	280	A200	4	80	70	80	75	12	9	540	A200	4	80	75	80	75	14	17	510	-	-	-	-	-	-	-	-	
	315 2)	A225	4	90	70	90	80	0	-2	547	-	-	-	-	-	-	-	-	-	-	-	-	-	-	-	-		
133 / 143	250	-	-	-	-	-	-	-	-	-	-	-	-	-	-	-	-	-	A180	4	70	50	70	65	5	9.5	578.5	
	280	-	-	-	-	-	-	-	-	A200	4	80	60	80	75	0	10	599	A200	4	80	50	80	75	5	30	599	
	315 2)	A225	4	90	85	90	80	18	4	666	A225	4	90	60	90	80	0	17	636	A200	4	80	50	80	75	5	30	599
153 / 163	280	-	-	-	-	-	-	-	-	-	-	-	-	-	-	-	-	-	A200	4	80	60	80	75	0	13	647	
	315 2)	-	-	-	-	-	-	-	-	A225	4	90	75	90	80	8	12	684	A225	4	90	60	90	80	0	20	684	
173 / 183	315 2)	-	-	-	-	-	-	-	-	-	-	-	-	-	-	-	-	-	A225	4	90	60	90	80	0	20	714	

TR

KAPLİN N
IEC BAĞLANTILI MOTORLAR

EN

MOTOR BELL HOUSING FOR
IEC STANDARD MOTORS WITH
N COUPLING

DE

MOTORLATERNE FÜR IEC - MOTOREN
MIT N - KUPPLUNG

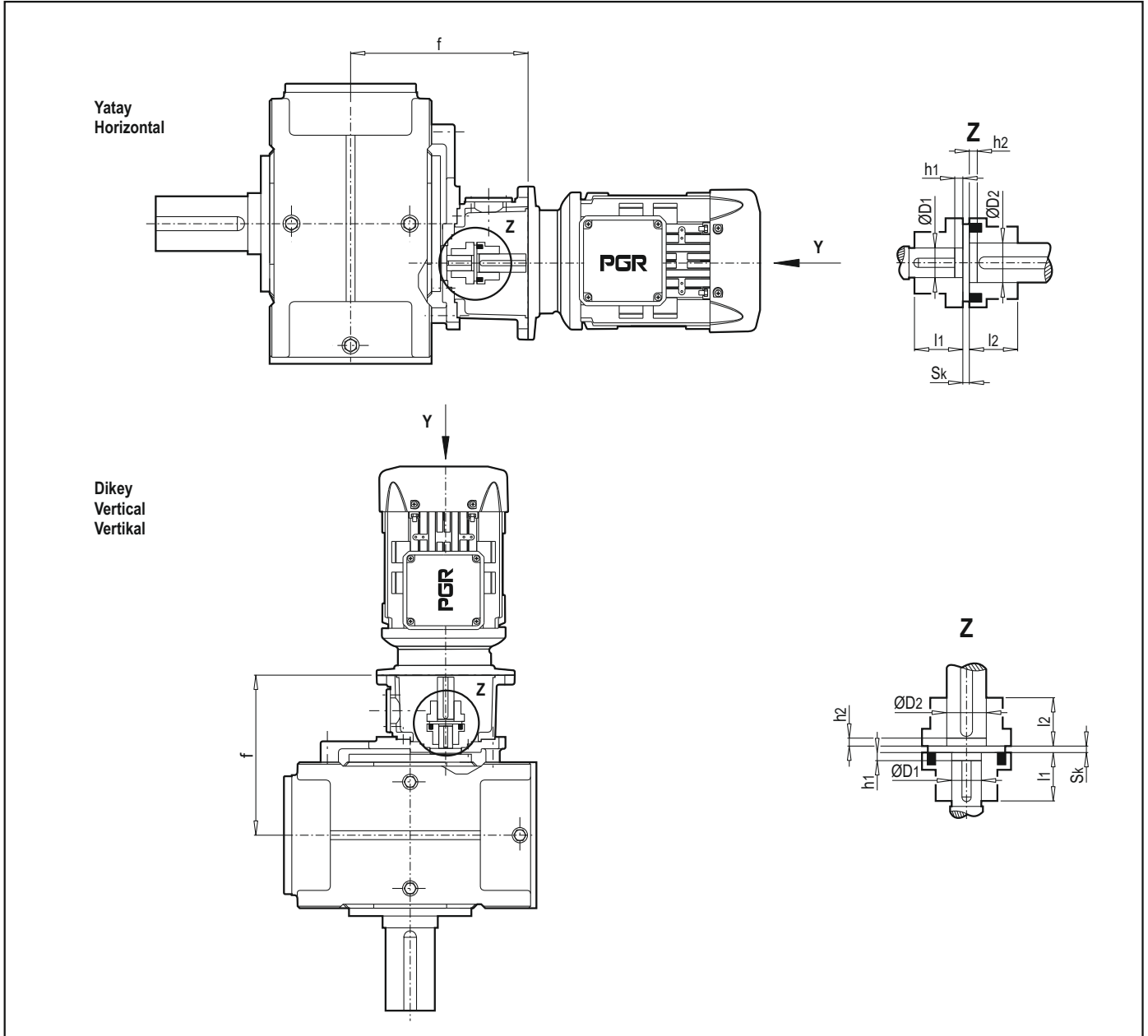

Özel tasarım gerektiren tesisler için (yüksek açma kapama frekansı ve değişken yük istikametleri, örneğin kaldırma makineleri, hareketli taşıtlar ve benzeri), güncel ve geçerli kaplin katalogundan kontrol edilerek, uygun kaplin seçimi yapılır. Bunlardan farklı kaplin gerektiren durumlarda, mutlaka PGR ile görüşülmelidir!

For plants with special design requirements (high switching frequency, alternating direction of load; e.g. hoisting gears, travelling gears, etc) the coupling design is to be checked in accordance with the respective valid coupling brochure. For other couplings, please consult PGR!

Bei Anlagen mit besonderen Auslegungsanforderungen (große Schalthäufigkeit, wechselnde Lastrichtung; z.B. Hubwerke, Fahrwerke, usw.) ist die Auslegung der Kupplung nach dem jeweils gültigen Kupplungskatalog zu prüfen. Bei abweichenden Kupplungen ist Rücksprache mit PGR notwendig!

DIN 42677 IEC-Standard motorlarının montaj ölçüleri (Y bakış açısı) için, sayfa 162'ye bakın. G, H ve I modeli helisel dişli redüktörlerde, giriş milinde takonite E veya labirent keçe uygulaması yoktur, ancak talep üzerine uygulanır.

For fitting dimensions for IEC standard motors DIN 42677 (View Y), see page 162. Helical gear unit in G, H, I, design on request only. Not in connection with Taconite E or labyrinth seal on input shaft.

Anbaumaße für IEC-Normmotoren DIN 42677 (Ansicht Y) siehe Seite 162. Stinradgetriebe in Ausführung G, H, I nur auf Anfrage. Nicht in Verbindung mit Taconite E oder Labyrinth - Abdichtung an der Antriebswelle

1) Diğer motor büyüklükleri, talep üzerine temin edilir.
2) Sadece 315S ve 315M motor büyüklükleri.

1) Other motor sizes on request
2) Sizes 315S and 315M only

1) andere Motorgrößen auf Anfrage
2) nur Baugröße 315S und 315M

TR

**KAPLIN N
IEC BAĞLANTILI MOTORLAR**

EN

**MOTOR BELL HOUSING FOR
IEC STANDARD MOTORS WITH
N COUPLING**

DE

**MOTORLATERNE FÜR IEC - MOTOREN
MIT N - KUPPLUNG**

Tablo 10 / Table 10 / Tabelle 10

Gövde Size Größe	Motor ¹⁾ IEC	Tahviller İN / Ratios İN / Übersetzungen İN 100 - 180 (Gövdeler / Sizes / Größen 74,94,114) 125 - 224 (Gövdeler / Sizes / Größen 84,104,124) 100 - 180 (Gövdeler / Sizes / Größen 134,154,174) 125 - 224 (Gövde / Size / Größe 144) 112 - 200 (Gövdeler / Sizes / Größen 164,184)										Tahviller İN / Ratios İN / Übersetzungen İN 200 - 355 (Gövdeler / Sizes / Größen 74,94,114) 250 - 450 (Gövdeler / Sizes / Größen 84,104,124) 200 - 355 (Gövdeler / Sizes / Größen 134,154,174) 250 - 450 (Gövde / Size / Größe 144) 224 - 400 (Gövdeler / Sizes / Größen 164,184)											
		Kaplin N N Coupling N Kupplung	mm										Kaplin N N Coupling N Kupplung	mm									
			sk	l1	ØD1	l2	ØD2	h1	h2	f	sk	l1		ØD1	l2	ØD2	h1	h2	f				
74 / 84	100	-	-	-	-	-	-	-	-	-	-	B80	3	30	24	30	28	7	6	296			
	112	-	-	-	-	-	-	-	-	-	-	B80	3	30	24	30	28	7	6	296			
	132	B95	3	35	30	35	38	7	8	328.5	-	-	-	-	-	-	-	-	-	-			
	160	A125	3	50	30	50	42	6.5	15	364.5	A125	3	50	24	50	42	16.5	15	364.5	-			
	180	A140	3	55	30	55	48	17	4.5	364.5	-	-	-	-	-	-	-	-	-	-			
94 / 104	132	-	-	-	-	-	-	-	-	-	B95	3	35	28	35	38	10	11.5	369.5	-			
	160	A125	3	50	35	50	42	6.5	11	405.5	A125	3	50	28	50	42	13	14.5	405.5	-			
	180	A140	3	55	35	55	48	10	7.5	405.5	A140	3	55	28	55	48	20	7.5	405.5	-			
	200	A160	4	60	35	60	55	10	14.5	417.5	-	-	-	-	-	-	-	-	-	-			
	225	A180	4	70	35	70	60	18.5	21	458.5	-	-	-	-	-	-	-	-	-	-			
114 / 124	160	-	-	-	-	-	-	-	-	-	A125	3	50	32	50	42	0	4.5	447.5	-			
	180	A140	3	55	45	55	48	7	3.5	437.5	A140	3	55	32	55	48	0	4.5	447.5	-			
	200	A160	4	60	45	60	55	6.5	15	485.5	A160	4	60	32	60	55	0	15.5	459.5	-			
	225	A180	4	70	45	70	60	0	6.5	500.5	A180	4	70	32	70	60	3	23.5	500.5	-			
	250	A180	4	70	45	70	65	0	6.5	500.5	-	-	-	-	-	-	-	-	-	-			
134 / 144	160	-	-	-	-	-	-	-	-	-	A125	3	50	38	50	42	9	10.5	517.5	-			
	180	-	-	-	-	-	-	-	-	-	A140	3	55	38	55	48	3.5	16	517.5	-			
	200	A160	4	60	50	60	55	2	8.5	529.5	A160	4	60	38	60	55	0	4.5	503.5	-			
	225	A180	4	70	50	70	60	9.5	21	579.5	A180	4	70	38	70	60	4	11.5	544.5	-			
	250	A180	4	70	50	70	65	7.5	23	579.5	A180	4	70	38	70	65	4	11.5	544.5	-			
	280	A200	4	80	50	80	75	0	16	565	-	-	-	-	-	-	-	-	-	-			
	315 ²⁾	-	-	-	-	-	-	-	-	-	-	-	-	-	-	-	-	-	-	-			
154 / 164	200	-	-	-	-	-	-	-	-	-	A160	4	60	50	60	55	0	3.5	572.5	-			
	225	A180	4	70	60	70	60	15.5	9	648.5	A180	4	70	50	70	60	0	14.5	613.5	-			
	250	A180	4	70	60	70	65	13.5	11	648.5	A180	4	70	50	70	65	0	14.5	613.5	-			
	280	A200	4	80	60	80	75	0	10	634	A200	4	80	50	80	75	3	32	634	-			
	315 ²⁾	A225	4	90	60	90	80	0	17	671	-	-	-	-	-	-	-	-	-	-			
174 / 184	225	-	-	-	-	-	-	-	-	-	A180	4	70	50	70	60	3	16.5	623.5	-			
	250	-	-	-	-	-	-	-	-	-	A180	4	70	50	70	65	4	15.5	623.5	-			
	280	A200	4	80	60	80	75	5	10	644	A200	4	80	50	80	75	6	34	644	-			
	315 ²⁾	A225	4	90	60	90	80	0	22	681	-	-	-	-	-	-	-	-	-				

TR

KAPLİN N
IEC BAĞLANTILI MOTORLAR

EN

MOTOR BELL HOUSING FOR
IEC STANDARD MOTORS WITH
N COUPLING

DE

MOTORLATERNE FÜR IEC - MOTOREN
MIT N - KUPPLUNG

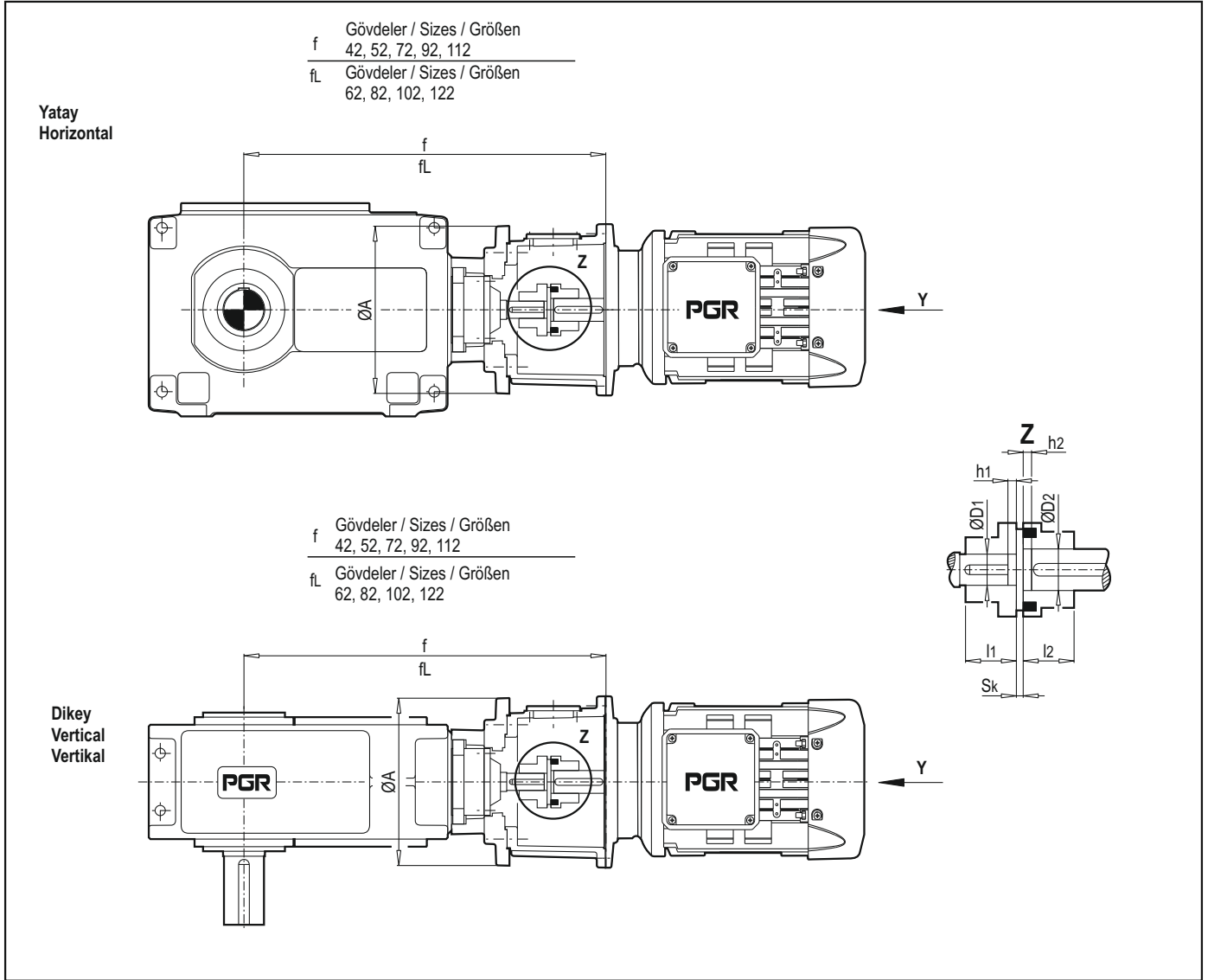

Özel tasarım gerektiren tesisler için (yüksek açma kapama frekansı ve değişken yük istikametleri, örneğin kaldırma makineleri, hareketli taşıtlar ve benzeri), güncel ve geçerli kaplin kataloğundan kontrol edilerek, uygun kaplin seçimi yapılır. Bunlardan farklı kaplin gerektiren durumlarda, mutlaka PGR ile görüşülmelidir!

For plants with special design requirements (high switching frequency, alternating direction of load; e.g. hoisting gears, travelling gears, etc) the coupling design is to be checked in accordance with the respective valid coupling brochure. For other couplings, please consult PGR!

Bei Anlagen mit besonderen Auslegungsanforderungen (große Schalthäufigkeit, wechselnde Laststrichtung; z.B. Hubwerke, Fahrwerke, usw.) ist die Auslegung der Kupplung nach dem jeweils gültigen Kupplungskatalog zu prüfen. Bei abweichenden Kupplungen ist Rücksprache mit PGR notwendig!

DIN 42677 IEC-Standard motorlarının montaj ölçüleri (Y bakış açısı) için, sayfa 162'ye bakın. G, H ve I modeli helisel dişli redüktörlerde, giriş milinde takonite E veya labirent keçe uygulaması yoktur, ancak talep üzerine uygulanır.

For fitting dimensions for IEC standard motors DIN 42677 (View Y), see page 162. Not in connection with Taconite E or labyrinth seal on input shaft.

Anbaumaße für IEC-Normmotoren DIN 42677 (Ansicht Y) siehe Seite 162. Stinradgetriebe in Ausführung G, H, I nur auf Anfrage. Nicht in Verbindung mit Taconite E oder Labyrinth - Abdichtung an der Antriebswelle

1) Diğer motor büyüklükleri, talep üzerine temin edilir.
2) Sadece 315S ve 315M motor büyüklükleri.

1) Other motor sizes on request
2) Sizes 315S and 315M only

1) andere Motorgrößen auf Anfrage
2) nur Baugröße 315S und 315M

TR

KAPLIN N
IEC BAĞLANTILI MOTORLAR

EN

MOTOR BELL HOUSING FOR
IEC STANDARD MOTORS WITH
N COUPLING

DE

MOTORLATERNE FÜR IEC - MOTOREN
MIT N - KUPPLUNG

Tablo 11 / Table 11 / Tabelle 11

		Tahviller İN / Ratios İN / Übersetzungen İN 5 - 11.2 (Gövdeler / Sizes / Größen 42, 52, 72,92,112) 6.3 - 14 (Gövdeler / Sizes / Größen 62, 82,102,122)											
Gövde Size Größe	Motor ¹⁾ IEC	Kaplin N N Coupling N Kupplung	mm										
			sk	l1	ØD1	l2	ØD2	h1	h2	f	fL	ØA	
42	180	-	-	-	-	-	-	-	-	-	-	-	-
	200	A160	4	60	45	60	55	0	5.5	684.5	-	400	
52 / 62	200	-	-	-	-	-	-	-	-	-	-	-	
	225	-	-	-	-	-	-	-	-	-	-	-	
72 / 82	250	-	-	-	-	-	-	-	-	-	-	-	
	280	A200	4	80	70	80	75	9	6	934	979	550	
92 / 102	280	-	-	-	-	-	-	-	-	-	-	-	
112 / 122	315 ²⁾	-	-	-	-	-	-	-	-	-	-	-	

TR

KAPLİN N
IEC BAĞLANTILI MOTORLAR

EN

MOTOR BELL HOUSING FOR
IEC STANDARD MOTORS WITH
N COUPLING

DE

MOTORLATERNE FÜR IEC - MOTOREN
MIT N - KUPPLUNG

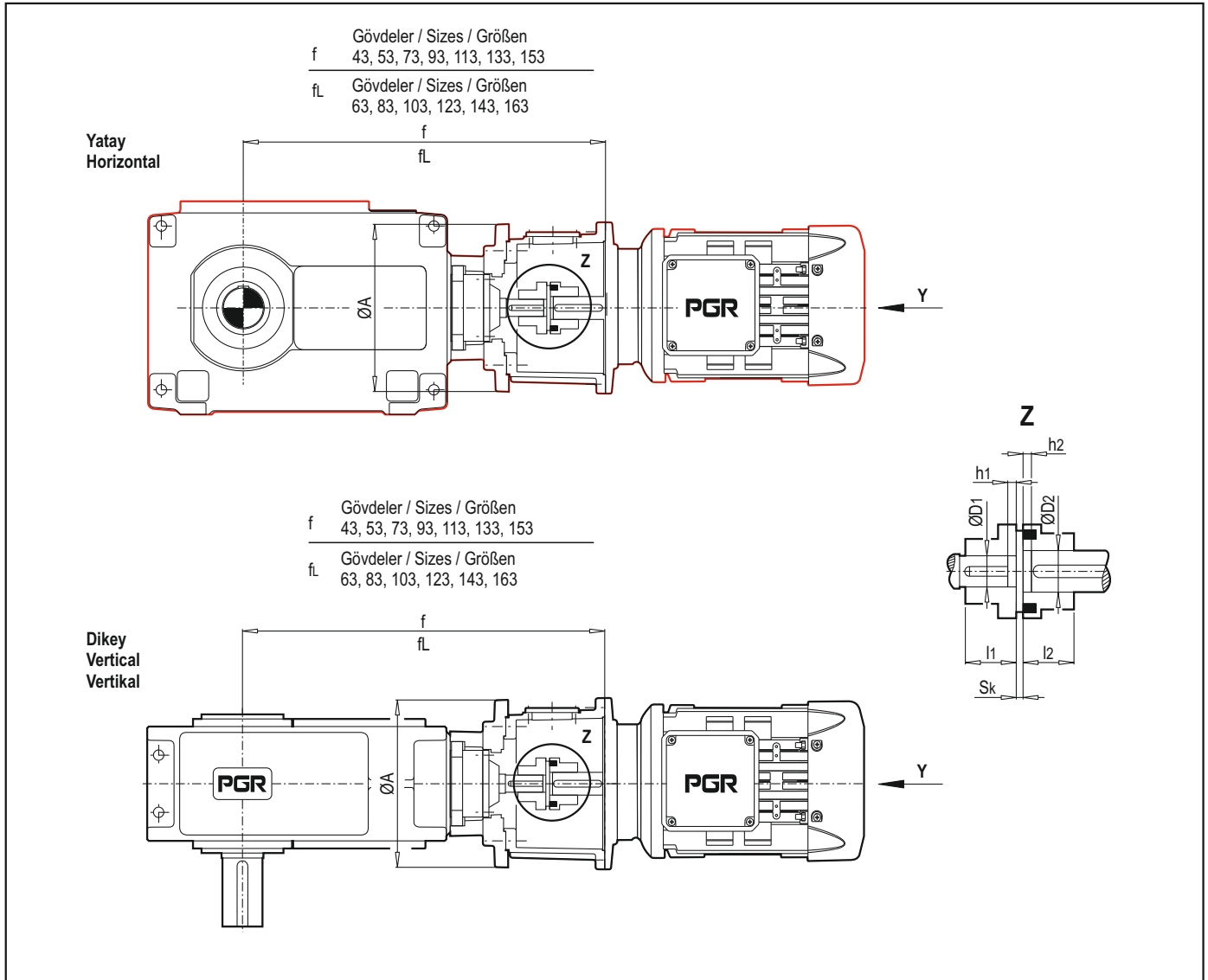

Özel tasarım gerektiren tesisler için (yüksek açma kapama frekansı ve değişken yük istikametleri, örneğin kaldırma makineleri, hareketli taşıtlar ve benzeri), güncel ve geçerli kaplin katalogundan kontrol edilerek, uygun kaplin seçimi yapılır. Bunlardan farklı kaplin gerektiren durumlarda, mutlaka PGR ile görüşülmelidir!

DIN 42677 IEC-Standard motorlarının montaj ölçüleri (Y bakış açısı) için, sayfa 162'ye bakın. G, H ve I modeli helisel dişli redüktörlerde, giriş milinde takonite E veya labirent keçe uygulaması yoktur, ancak talep üzerine uygulanır.

For plants with special design requirements (high switching frequency, alternating direction of load; e.g. hoisting gears, travelling gears, etc) the coupling design is to be checked in accordance with the respective valid coupling brochure. For other couplings, please consult PGR!

For fitting dimensions for IEC standard motors DIN 42677 (View Y), see page 162.
Not in connection with Taconite E or labyrinth seal on input shaft.

Bei Anlagen mit besonderen Auslegungsanforderungen (große Schalthäufigkeit, wechselnde Lastrichtung; z.B. Hubwerke, Fahrwerke, usw.) ist die Auslegung der Kupplung nach dem jeweils gültigen Kupplungskatalog zu prüfen. Bei abweichenden Kupplungen ist Rücksprache mit PGR notwendig!

Anbaumaße für IEC-Normmotoren DIN 42677 (Ansicht Y) siehe Seite 162. Stinradgetriebe in Ausführung G, H, I nur auf Anfrage. Nicht in Verbindung mit Taconite E oder Labyrinth - Abdichtung an der Antriebswelle

1) Diğer motor büyüklükleri, talep üzerine temin edilir.
2) Sadece 315S ve 315M motor büyüklükleri.

1) Other motor sizes on request
2) Sizes 315S and 315M only

1) andere Motorgößen auf Anfrage
2) nur Baugröße 315S und 315M

TR KAPLIN N
IEC BAĞLANTILI MOTORLAR

EN MOTOR BELL HOUSING FOR
IEC STANDARD MOTORS WITH
N COUPLING

DE MOTORLATERNE FÜR IEC - MOTOREN
MIT N - KUPPLUNG

Tablo 12 / Table 12 / Tabelle 12																								
Gövde Size Größe	Motor ¹⁾ IEC	Tahviller İN / Ratios İN / Übersetzungen İN 12.5 - 45 (Gövdeler / Sizes / Größen 33,43,53,73,93,113) 16 - 56 (Gövdeler / Sizes / Größen 63, 83,103,123) 12.5 - 45 (Gövdeler / Sizes / Größen 133,153) 16 - 56 (Gövde / Size / Größe 143) 14 - 50 (Gövdeler / Sizes / Größen 163)											Tahviller İN / Ratios İN / Übersetzungen İN 50 - 71 (Gövdeler / Sizes / Größen 33, 43, 53, 73,93,113) 63 - 90 (Gövdeler / Sizes / Größen 63, 83,103,123) 50 - 71 (Gövdeler / Sizes / Größen 133,153) 63 - 90 (Gövde / Size / Größe 143) 56 - 80 (Gövdeler / Sizes / Größen 163)											
		Kaplin N N Coupling N Kupplung	mm											Kaplin N N Coupling N Kupplung	mm									
			sk	l1	ØD1	l2	ØD2	h1	h2	f	fl	ØA	sk		l1	ØD1	l2	ØD2	h1	h2	f	fl	ØA	
43	132	-	-	-	-	-	-	-	-	-	-	-	-	B95	3	35	25	35	38	0	4.5	646.5	-	250
	160	A125	3	50	30	50	42	0	-0.5	682.5	-	250	A125	3	50	25	50	42	0	9.5	682.5	-	250	
	180	A140	3	55	30	55	48	0	-0.5	682.5	-	250	A140	3	55	25	55	48	0	9.5	682.5	-	250	
	200	A160	4	60	30	60	55	0	10.5	694.5	-	250	-	-	-	-	-	-	-	-	-	-	-	
53 / 63	160	A125	3	50	35	50	42	0	3.5	771.5	806.5	340	A125	3	50	28	50	42	7	16.5	771.5	806.5	340	
	180	A140	3	55	35	55	48	0	3.5	771.5	806.5	340	A140	3	55	28	55	48	2	21.5	771.5	806.5	340	
	200	A160	4	60	35	60	55	0	14.5	783.5	818.5	340	A160	4	60	28	60	55	7.5	27	783.5	818.5	340	
	225	A180	4	70	35	70	60	7.5	18	824.5	859.5	340	-	-	-	-	-	-	-	-	-	-	-	
73 / 83	160	-	-	-	-	-	-	-	-	-	-	-	A125	3	50	35	50	42	8	12.5	903.5	948.5	440	
	180	-	-	-	-	-	-	-	-	-	-	-	A140	3	55	35	55	48	3	17.5	903.5	948.5	440	
	200	A160	4	60	45	60	55	0	5.5	909.5	954.5	440	A160	4	60	35	60	55	0	1.5	909.5	930.5	440	
	225	A180	4	70	45	70	60	0	1.5	935.5	980.5	440	A180	4	70	35	70	60	0	21.5	935.5	980.5	440	
	250	A180	4	70	45	70	65	0	1.5	935.5	980.5	440	A180	4	70	35	70	65	0	21.5	935.5	980.5	440	
	280	A200	4	80	45	80	75	0	17	950.5	945.5	440	-	-	-	-	-	-	-	-	-	-	-	
93 / 103	200	-	-	-	-	-	-	-	-	-	-	-	A160	4	60	40	60	55	0	20.5	1034.5	1084.5	440	
	225	A180	4	70	55	70	60	1.5	5	1060.5	1110.5	440	A180	4	70	40	70	60	0	16.5	1060.5	1110.5	440	
	250	A180	4	70	55	70	65	0	6.5	1060.5	1110.5	440	A180	4	70	40	70	65	0	16.5	1060.5	1110.5	440	
	280	A200	4	80	55	80	75	0	22	1046	1096.5	440	A200	4	80	40	80	75	0	2	1046	1096	440	
113 / 123	225	-	-	-	-	-	-	-	-	-	-	-	A180	4	70	50	70	60	9	20.5	1243.5	1313.5	440	
	250	A180	4	70	70	70	65	4.5	0	1243.5	1313.5	440	A180	4	70	50	70	65	9	20.5	1243.5	1313.5	440	
	280	A200	4	80	70	80	75	12	8	1258.5	1328.5	440	A200	4	80	50	80	75	0	15	1229	1299	440	
	315 ²⁾	A225	4	90	70	90	80	10	17	1296	1366	440	A225	4	90	50	90	80	0	22	1266	1336	440	
133 / 143	280	-	-	-	-	-	-	-	-	-	-	-	A200	4	80	60	80	75	0	15	1424	1494	445	
	315 ²⁾	A225	4	90	80	90	80	9	8	1481	1551	445	A225	4	90	60	90	80	0	22	1461	1531	445	
153 / 163	315 ²⁾	-	-	-	-	-	-	-	-	-	-	-	A225	4	90	70	90	80	3	14	1698	1744	520	

TR

KAPLİN N
IEC BAĞLANTILI MOTORLAR

EN

MOTOR BELL HOUSING FOR
IEC STANDARD MOTORS WITH
N COUPLING

DE

MOTORLATERNE FÜR IEC - MOTOREN
MIT N - KUPPLUNG

Yatay
Horizontal

f Gövdeler / Sizes / Größen
54, 74, 94, 114, 134, 154, 174

fL Gövdeler / Sizes / Größen
64, 84, 104, 124, 144, 164, 184

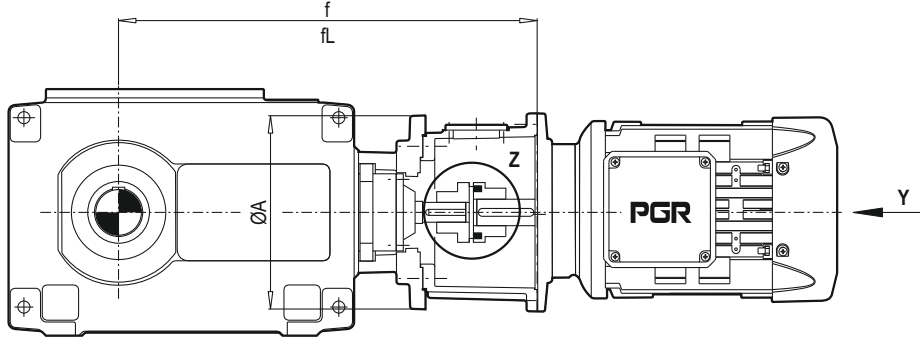

Dikey
Vertical

f Gövdeler / Sizes / Größen
54, 74, 94, 114, 134, 154, 174

fL Gövdeler / Sizes / Größen
64, 84, 104, 124, 144, 164, 184

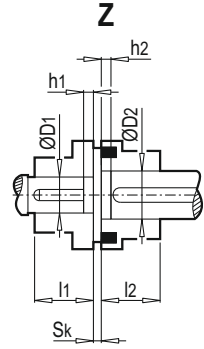
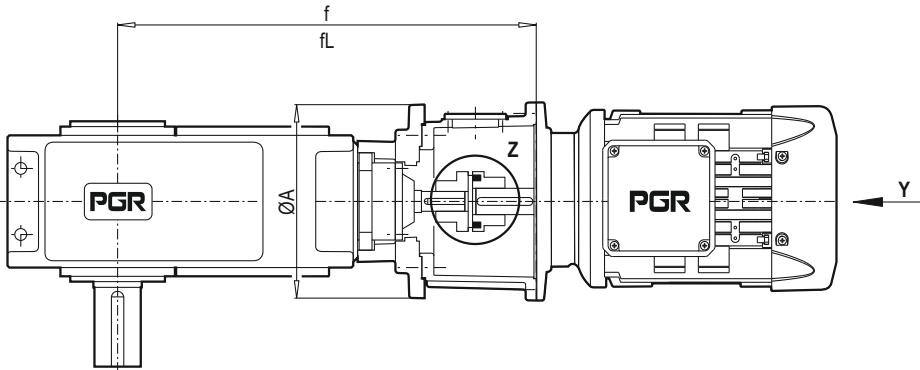

Özel tasarım gerektiren tesisler için (yüksek açma kapama frekansı ve değişken yük istikametleri, örneğin kaldırma makineleri, hareketli taşıtlar ve benzeri), güncel ve geçerli kaplin kataloğundan kontrol edilerek, uygun kaplin seçimi yapılır. Bunlardan farklı kaplin gerektiren durumlarda, mutlaka PGR ile görüşülmelidir!

For plants with special design requirements (high switching frequency, alternating direction of load; e.g. hoisting gears, travelling gears, etc) the coupling design is to be checked in accordance with the respective valid coupling brochure. For other couplings, please consult PGR!

Bei Anlagen mit besonderen Auslegungsanforderungen (große Schalthäufigkeit, wechselnde Lastrichtung; z.B. Hubwerke, Fahrwerke, usw.) ist die Auslegung der Kupplung nach dem jeweils gültigen Kupplungskatalog zu prüfen. Bei abweichenden Kupplungen ist Rücksprache mit PGR notwendig!

DIN 42677 IEC-Standard motorlarının montaj ölçüleri (Y bakış açısı) için, sayfa 162'ye bakın. G, H ve I modeli helisel dişli redüktörlerde, giriş milinde takonite E veya labirent keçe uygulaması yoktur, ancak talep üzerine uygulanır.

For fitting dimensions for IEC standard motors DIN 42677 (View Y), see page 162. Not in connection with Taconite E or labyrinth seal on input shaft.

Anbaumaße für IEC-Normmotoren DIN 42677 (Ansicht Y) siehe Seite 162. Nicht in Verbindung mit Taconite E oder Labyrinth-Abdichtung an der Antriebswelle

1) Diğer motor büyüklükleri, talep üzerine temin edilir.
2) Sadece 315S ve 315M motor büyüklükleri.

1) Other motor sizes on request
2) Sizes 315S and 315M only

1) andere Motorgrößen auf Anfrage
2) nur Baugröße 315S und 315M

TR KAPLIN N
IEC BAĞLANTILI MOTORLAR

EN MOTOR BELL HOUSING FOR
IEC STANDARD MOTORS WITH
N COUPLING

DE MOTORLATERNE FÜR IEC - MOTOREN
MIT N - KUPPLUNG

Tablo 13 / Table 13 / Tabelle 13																								
Gövde Size Größe	Motor IEC	Tahviller İN / Ratios İN / Übersetzungen İN 80 - 180 (Gövdeler / Sizes / Größen 54, 74,94,114) 100 - 224 (Gövdeler / Sizes / Größen 64, 84,104,124) 80 - 180 (Gövdeler / Sizes / Größen 134,154,174) 100 - 224 (Gövde / Size / Größe 144) 90 - 200 (Gövdeler / Sizes / Größen 164,184)											Tahviller İN / Ratios İN / Übersetzungen İN 200 - 315 (Gövdeler / Sizes / Größen 54, 74,94,114) 250 - 400 (Gövdeler / Sizes / Größen 64, 84,104,124) 200 - 315 (Gövdeler / Sizes / Größen 134,154,174) 250 - 400 (Gövde / Size / Größe 144) 224 - 355 (Gövdeler / Sizes / Größen 164,184)											
		Kaplin N N Coupling N Kupplung	mm											Kaplin N N Coupling N Kupplung	mm									
			sk	l1	D1	l2	D2	h1	h2	f	fL	A	sk		l1	D1	l2	D2	h1	h2	f	fL	A	
54 / 64	100	-	-	-	-	-	-	-	-	-	-	-	-	B80	3	30	20	30	28	0	6	734	769	245
	112	B80	3	30	28	30	28	0	1	734	769	245	B80	3	30	20	30	28	0	6	734	769	245	
	132	B95	3	35	28	35	38	5.5	8	766.5	801.5	245	B95	3	35	20	35	38	6	12.5	766.5	801.5	245	
	160	A125	3	50	28	50	42	4.5	15	802.5	837.5	245	-	-	-	-	-	-	-	-	-	-	-	
74 / 84	112	-	-	-	-	-	-	-	-	-	-	-	-	B80	3	30	25	30	28	3.5	2.5	854	899	250
	132	B95	3	35	30	35	38	3	5.5	886.5	931.5	250	B95	3	35	25	35	38	0	3.5	871.5	916.5	250	
	160	A125	3	50	30	50	42	0	-0.5	907.5	952.5	250	A125	3	50	25	50	42	0	9.5	907.5	952.5	250	
	180	A140	3	55	30	55	48	0	-0.5	907.5	952.5	250	-	-	-	-	-	-	-	-	-	-	-	
	200	A160	4	60	30	60	55	0	10.5	919.5	964.5	250	-	-	-	-	-	-	-	-	-	-	-	
94 / 104	132	-	-	-	-	-	-	-	-	-	-	-	-	B95	3	35	28	35	38	7.5	10	1000.5	1050.5	340
	160	A125	3	50	35	50	42	0	3.5	1036.5	1086.5	340	A125	3	50	28	50	42	7	16.5	1036.5	1086.5	340	
	180	A140	3	55	35	55	48	0	3.5	1036.5	1086.5	340	A140	3	55	28	55	48	2	21.5	1036.5	1086.5	340	
	200	A160	4	60	35	60	55	0	14.5	1048.5	1098.5	340	-	-	-	-	-	-	-	-	-	-	-	
	225	A180	4	70	35	70	60	0	25.5	1089.5	1139.5	340	-	-	-	-	-	-	-	-	-	-	-	
114 / 124	160	-	-	-	-	-	-	-	-	-	-	-	-	A125	3	50	35	50	42	8	12.5	1223.5	1293.5	440
	180	A140	3	55	45	55	48	0.5	0	1223.5	1293.5	440	A140	3	55	35	55	48	3	17.5	1223.5	1293.5	440	
	200	A180	4	70	45	70	55	0	5.5	1229.5	1299.5	440	A180	4	70	35	70	55	0	1.5	1205.5	1275.5	440	
	225	A180	4	70	45	70	60	0	1.5	1255.5	1325.5	440	A180	4	70	35	70	60	0	21.5	1255.5	1325.5	440	
	250	A180	4	70	45	70	65	0	1.5	1255	1325	440	-	-	-	-	-	-	-	-	-	-	-	
	280	A200	4	80	45	80	75	0	17	1270.5	1340.5	440	-	-	-	-	-	-	-	-	-	-	-	
134 / 144	180	-	-	-	-	-	-	-	-	-	-	-	-	A140	3	55	40	55	48	3	12.5	1398.5	1468.5	440
	200	A160	4	60	55	60	55	7.5	3	1404.5	1474.5	440	A160	4	60	40	60	55	0	20.5	1404.5	1474.5	440	
	225	A180	4	70	55	70	60	1.5	5	1430.5	1500.5	440	A180	4	70	40	70	60	0	16.5	1430.5	1500.5	440	
	250	A180	4	70	55	70	65	0	6.5	1430	1500	440	A180	4	70	40	70	65	0	16.5	1430	1500	440	
	280	A200	4	80	55	80	75	0	22	1446	1516	440	A225	4	90	40	90	75	7	25	1446	1516	440	
	315 2)	A225	4	90	55	90	80	5	24	1483	1553	440	-	-	-	-	-	-	-	-	-	-		
154 / 164	200	-	-	-	-	-	-	-	-	-	-	-	-	A160	4	60	50	60	55	1	8.5	1635.5	1681.5	440
	225	A200	4	80	70	80	60	4.5	0	1685.5	1731.5	440	A180	4	70	50	70	60	9	20.5	1685.5	1731.5	440	
	250	A200	4	80	70	80	65	4.5	0	1685.5	1731.5	440	A180	4	70	50	70	65	7	22.5	1685.5	1731.5	440	
	280	A200	4	80	70	80	75	11.5	8.5	1701	1747	440	A200	4	80	50	80	75	0	15	1671	1717	440	
	315 2)	A225	4	90	70	90	80	10	17	1738	1784	440	A225	4	90	50	90	80	0	22	1708	1754	440	
174 / 184	225	-	-	-	-	-	-	-	-	-	-	-	-	A180	4	70	50	70	60	9	20.5	1733.5	1793.5	440
	250	-	-	-	-	-	-	-	-	-	-	-	-	A180	4	70	50	70	65	7	22.5	1733.5	1793.5	440
	280	A200	4	80	70	80	75	11.5	8.5	1749	1809	440	A200	4	80	50	80	75	0	15	1719	1779	440	
	315 2)	A225	4	90	70	90	80	9.5	17.5	1786	1846	440	A225	4	90	50	90	80	0	22	1756	1816	440	

TR REDÜKTÖR GÖVDELERİ İÇİN TİTREŞİM AZALTAN TORK KOLLARI

EN VIBRATION REDUCING - TORQUE REACTION ARMS FOR - GEAR HOUSINGS

DE SCHWINGUNGSDÄMPFENDE DREHMOMENTSTÜTZEN FÜR GETRIEBEGEHAUSE

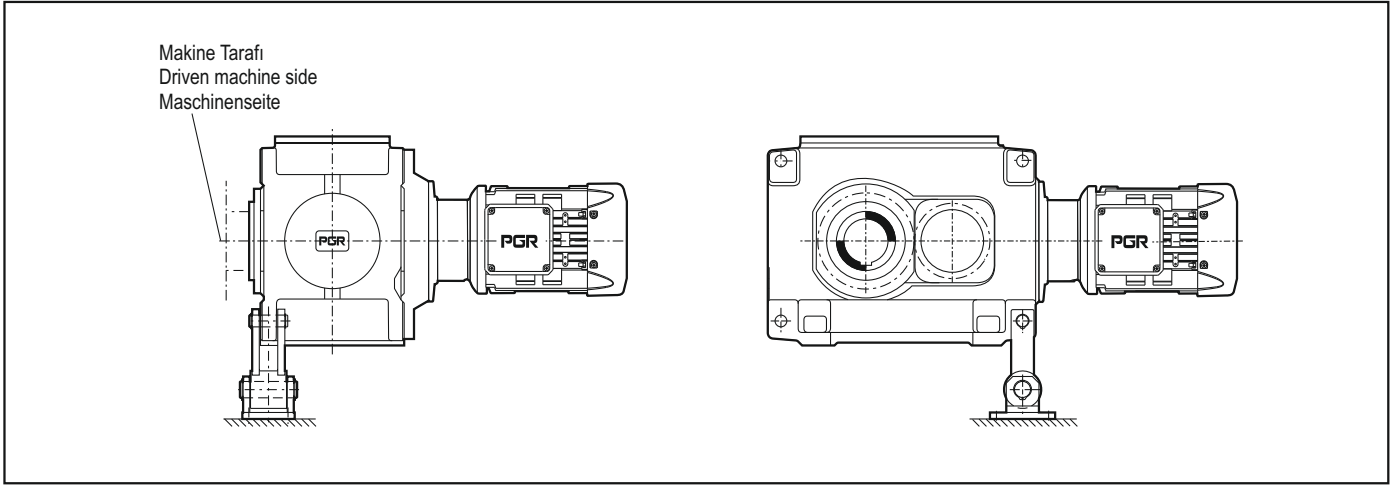

Maksimum aktarılabılır dönme momenti, dönme momenti destekleri yardımıyla sınırlandırılır:
 $T_{max} = f_{DMST} \times T_2 \text{ Nenn}$

The Maximum transmissible torque is limited by the torque reaction arm:
 $T_{max} = f_{DMST} \times T_2 \text{ Nenn}$

Das Maximal übertragbare Drehmoment ist durch die Drehmomentstütze begrenzt:
Es gilt: $T_{max} = f_{DMST} \times T_2 \text{ Nenn}$

Tablo 1 / Table 1 / Tabelle 1

Dönme momenti destekleri için f_{DMST} en yüksek dönme momenti faktörü ¹⁾
Peak torque factor f_{DMST} for torque reaction arm
Spitzendrehmomentfaktor f_{DMST} für Drehmomentstütze

Redüktör gövdeleri Gear unit size Getriebegröße	Tip / Type / Bauart					
	PH...2	PH...3	PH...4	PB...2	PB...3	PB...4
4...	1.3	-	-	1.2	1.2	-
5...	1.9	2.0	-	1.2	1.6	2.0
6...	1.6	1.7	-	1.2	1.4	1.7
7...	2.0	2.0	2.0	1.3	1.8	2.0
8...	1.7	2.0	2.0	1.2	1.6	2.0
9...	1.5	1.6	1.7	1.2	1.2	1.7
10...	1.3	1.4	1.4	1.2	1.2	1.4
11...	2.0	2.0	2.0	1.9	2.0	1.2
12...	2.0	2.0	2.0	1.8	2.0	1.2
13...	-	2.0	2.0	1.4	1.8	2.0
14...	-	1.9	2.0	1.3	1.7	2.0
15...	-	1.5	1.7	-	1.4	1.6
16...	-	1.4	1.5	-	1.3	1.5
17...	-	1.2	1.3	-	1.2	1.3
18...	-	1.2	1.2	-	1.2	1.2
19... - 22...	Talep edildiğinde / On request / Auf Anfrage					

1) Belirtilen Tablo değerleri, minimum değerlerdir.
Dönme yönü motor tipine bağlı olarak, daha yüksek dönme momenti değerlerine muhtemelen izin verilebilir.
Mutlaka PGR ile görüşülmelidir!

1) The values in the table are minimum values
Depending on direction of rotation and motortype, higher peak torques may possibly be allowed.
Please consult us!

1) Die genannten Tabellenwerte sind Mindestwerte.
Unter Angabe von Drehrichtung und Motortyp können gegebenenfalls höhere Spitzendrehmomente zugelassen werden. Rücksprache ist erforderlich!

TR REDÜKTÖR GÖVDELERİ İÇİN TİTREŞİM
AZALTAN TORK KOLLARI

EN VIBRATION REDUCING - TORQUE
REACTION ARMS FOR - GEAR HOUSINGS

DE SCHWINGUNGSDÄMPFENDE
DREHMOMENTSTÜTZEN FÜR
GETRIEBEGEHÄUSE

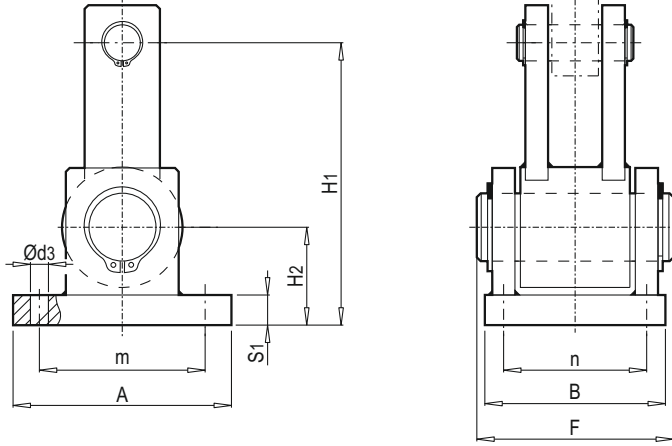

İş makinesi tarafındaki dönme momenti destekleri (C, D, G, H, I tipi helisel dişli redüktör modellerinde, sadece talep üzerine temin edilir). Motor bağlantı adaptörü bulunmayan redüktörlerde, sadece çapraz kuvvetlere maruz kalmayan kaplinler kullanılabilir.

Torque reaction arm on driven machine side. (helical gear unit in C, D, G, H, I design on request only.)

For gear units without motor bell housing only couplings not transmitting shear forces are allowed.

Torque reaction arm in combination with fan on request only.

Drehmomentstütze an der Arbeitsmaschinen-seite. (Stirnradgetriebe in Ausführung C, D, G, H, I nur auf Anfrage.)

Bei Getrieben ohne Motorlaterne sind nur Kupplungen zulässig, die keine Querkräfte übertragen können

Drehmomentstütze in Kombination mit Lüfter nur auf Anfrage

Tablo 2 / Table 2 / Tabelle 2

Redüktör Gövdesi Gear unit size Getriebegröße	A	B	Ød3	F	H1	H2	m	n	S1	Burç Bush Metelastik- Busche	Ağırlık Weight Gewicht
PH / PB 4...	160	110	19	116	200	65	120	70	15	079	6.8
PH / PB 5 + 6...	200	160	19	170	250	90	160	120	20	095	16
PH / PB 7 + 8...	320	200	19	195	400	140	260	130	25	772	37
PH / PB 9 + 10...											42
PH / PB 11 + 12...	400	300	24	320	500	175	320	240	30	805	155
PH / PB 13 + 14...											159
PH / PB 15 + 16...											163
PH / PB 17 + 18...											167
PH / PB 19 + 22...	Talep edildiğinde / On request / Auf Anfrage										

TR KAPLİN N, IEC-MOTORLU, KAPLİN BAĞLANTILI VE FRENLİ REDÜKTÖRLER

EN GEAR UNIT SWING-BASES WITH N COUPLINGS, IEC MOTORS AND ASSIGNED COUPLINGS AND BRAKES

DE GETRIEBESCHWINGEN MIT N - KUPPLUNGEN, IEC-MOTOREN UND ZUGEORDNETEN KUPPLUNGEN UND BREMSSEN

Tablo / Table / Tabelle 1

DIN 42673'e uygun IEC motoru IEC motor acc. to DIN 42673 IEC motor nach DIN 42673		DIN 15435'e uygun tambur frenli Kaplin N N - coupling with drum brake acc. to DIN 15435 N - Kupplung mit Trommelbremse nach DIN 15435			
Gövde Size Größe	Mil ucu Shaft end Wellenende ØD x E mm	Kaplin N Kaplin boyutları coupling size Kupplung Größe 2)	Kaplin N Kaplin boyutları coupling size Kupplung Größe 3)	Fren tamburu Brake drum Bremstrommel Ød x l mm	Fren tamburunun boyutu Drum brake size Trommelbremse Größe
100	28 x 60	80	125	200 x 75	TE 200
112	28 x 60	80	125	200 x 75	TE 200
132	38 x 80	95	125	200 x 75	TE 200
160 M	42 x 110	110	125	200 x 75	TE 200
160 L	42 x 110	125	125	200 x 75	TE 200
180 M	48 x 110	125	140	250 x 95	TE 250
180 L	48 x 110	140	140	250 x 95	TE 250
200	55 x 110	160	160	250 x 95	TE 250
225	60 x 140	160	180	315 x 118	TE 315
250	65 x 140	180	180	315 x 118	TE 315
280 S	75 x 140	200	225	400 x 150	TE 400
280 M	75 x 140	200	225	400 x 150	TE 400
315 S	80 x 170	200	225	400 x 150	TE 400
315 M	80 x 170	225	225	400 x 150	TE 400
315 LB	80 x 170	250	250	500 x 150	TE 500
355 MB	90 x 170	250	250	500 x 150	TE 500
355 LB	90 x 170	280	280	500 x 150	TE 500
400 MB	100 x 210	315	280	500 x 190	TE 500
400 MD	100 x 210	315	280	500 x 190	TE 500

2) Tip A110 büyüklüğünden
Tip B95 modelleri
3) Tip P

Fren diskli Kaplin N, sadece talep üzerine temin edilir.

2) Type A from size 110 up;
Type B up to size 95
3) Type P

N couplings with brake disk on request.

2) Bauart A ab Größe 110;
Bauart B bis Größe 95
3) Bauart P

N Kupplungen mit Bremsscheibe auf Anfrage.

TR KAPLİN N REDÜKTÖRLER

EN GEAR UNIT SWING-BASES WITH
N COUPLINGS

DE GETRIEBESCHWINGEN MIT
N KUPPLUNGEN

DIN 42673'e uygun IEC motoru
IEC motor acc. to DIN 42673
IEC motor nach DIN 42673

Kaplin N
N coupling
N Kupplung

Kaplin koruması
Coupling guard
Schutzhaube

Fan / Fan / Lüfter

Helisel - Konik dişli Ünitesi
Bevel - helical gear unit
Kegelstirnradgetriebe

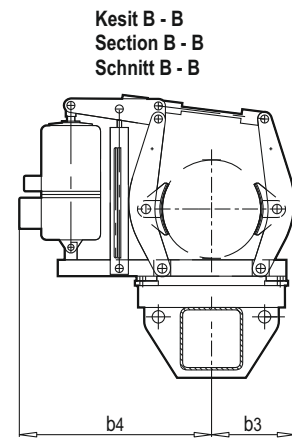
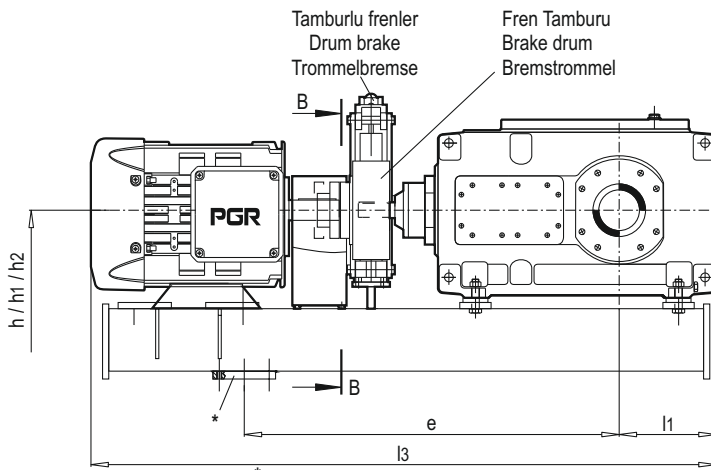
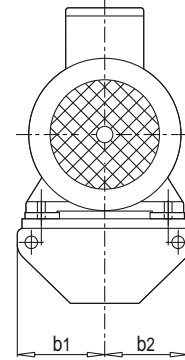
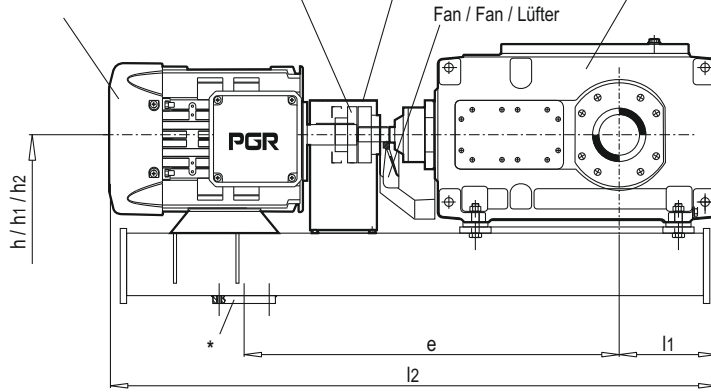

Kesit B - B
Section B - B
Schnitt B - B

Bağlantı Plakası
Connection plate
Anschlußplatte

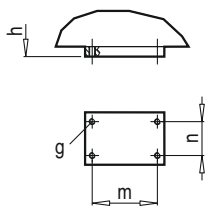

Elastik Destek
Flexible pedestal
elastischer Stützbock

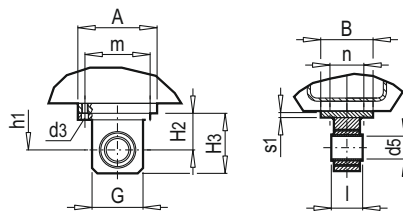

Torkolu
Torque reaction arm
Drehmomentstütze

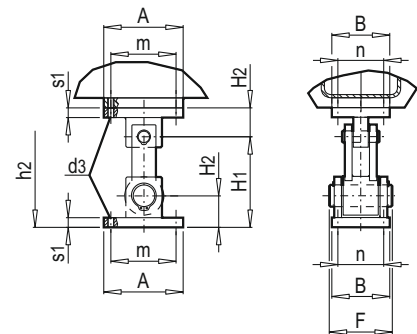

Tablo 2 / Table 2 / Tabelle 2

Gövde Size Größe	Burç Bush Buchse	mm														Ağırlık / Weight / Gewicht	
		m	n	g	Ød3	A	B	Ød5	f	G	H1	H2	H3	l	s1	Destek Pedestal Stützbock kg	Dönme momenti destekleri Torque reaction arm Drehmomentstütze kg
4...	069	95	65	M 12	15	120	90	25	96	60	180	50	80	56	12	2.1	5.8
5... / 6...	079	120	70	M 16	19	160	110	32	116	75	200	65	105	72	15	5.3	11.8
7... / 10...	095	160	120	M 16	19	200	160	50	170	110	250	90	145	110	20	16	34
11... / 12...	772	260	130	M 16	19	320	200	100	195	180	400	140	230	120	25	50	82

TR KAPLİN N REDÜKTÖRLER

EN GEAR UNIT SWING-BASES WITH N COUPLINGS

DE GETRIEBESCHWINGEN MIT N KUPPLUNGEN

Tablo 3 / Table 3 / Tabelle 3																							
Tip Gövde Type Size Bauart Größe	DIN 42673'e göre IEC'li motor IEC motor acc. to DIN 42673 IEC motor nach DIN 42673							Kaplin N N Coupling N Kupplung				Kaplin N Fren Tambur kaplini N coupling with drum brake N Kupplung mit Trommelbremse											
		e	h	h1	h2	l1	b1	b2	İN = 12.5 - 45		İN = 50 - 71		b3	b4	İN = 12.5 - 45		İN = 50 - 71						
									İN = 16 - 56	İN = 63 - 90	İN = 16 - 56	İN = 63 - 90											
		mm																l2 ²⁾	l2 ^{*2)}	l2 ²⁾	l2 ^{*2)}	l3 ²⁾	l3 ^{*2)}
PB43	132 S	950	380	430	610	190	160	145	-	-	1194	1194	170	470	-	-	1237						
	132 M								-	-	1232	1232			-	-	1275						
	160 M								1343	1343	1333	1333			1376	1376							
	160 L								1387	1387	1377	1387			1420	1420							
	180 M								1409	1409	1399	1409			1465	1465							
	180 L								1447	1452	-	-			1503	-							
200 L	1529	1534	-	-	1585	-																	
PB53	160 M	1000	450	515	715	205	185	170	-	-	1423	1423	170	470	-	-	1466						
	160 L								1487	1487	1467	1477			1515	1510							
	180 M								1509	1509	1489	1499			1555	1555							
	180 L								1547	1547	1527	1542			1593	1593							
	200 L								1629	1629	-	-			1675	-							
	225 S								1682	1682	-	-			1759	-							
225 M	1707	1707	-	-	1784	-																	
PB63	160 M	1050	450	515	715	250	185	170	-	-	1503	1503	170	470	-	-	1546						
	160 L								1567	1567	1547	1557			1595	1590							
	180 M								1589	1589	1569	1579			1635	1635							
	180 L								1627	1627	1607	1622			1673	1673							
	200 L								1709	1709	-	-			1755	-							
	225 S								1762	1762	-	-			1839	-							
225 M	1787	1787	-	-	1864	-																	
PB73	180 M	1150	540	630	880	250	215	185	-	-	1669	1669	210	590	-	-	1715						
	180 L								-	-	1707	1707			-	-	1753						
	200 L								1809	1809	1789	1789			1840	1835							
	225 S								1862	1862	1842	1842			1919	1919							
	225 M								1887	1887	1867	1867			1944	1944							
	250 M								1974	1974	-	-			2031	-							
280 S	2048	2048	-	-	2147	-																	
280 M	2099	2099	-	-	2198	-																	
PB83	180 M	1200	540	630	880	310	215	185	-	-	1774	1774	210	590	-	-	1820						
	180 L								-	-	1812	1812			-	-	1858						
	200 L								1914	1914	1894	1894			1945	1940							
	225 S								1967	1967	1947	1947			2024	2024							
	225 M								1992	1992	1972	1972			2049	2049							
	250 M								2079	2079	-	-			2136	-							
280 S	2153	2153	-	-	2252	-																	
280 M	2204	2204	-	-	2303	-																	
PB93	200 L	1350	630	720	970	300	260	215	-	-	1969	1969	210	590	-	-	2000						
	225 S								-	-	2022	2022			-	-	2079						
	225 M								2057	2057	2047	2047			2104	2104							
	250 M								2144	2144	2134	2134			2191	2191							
	280 S								2218	2218	2208	2208			2307	2307							
	280 M								2269	2269	-	-			2358	-							
PB103	200 L	1400	630	720	970	350	260	215	-	-	2069	2069	210	590	-	-	2100						
	225 S								-	-	2122	2122			-	-	2179						
	225 M								2157	2157	2147	2147			2204	2204							
	250 M								2244	2244	2234	2234			2291	2291							
	280 S								2318	2318	2308	2308			2407	2407							
	280 M								2369	2369	-	-			2458	-							
PB113	250 M	1550	740	880	1280	345	355	265	-	-	2349	2349	260	665	-	-	2396						
	280 S								-	-	2423	2423			-	-	2512						
	280 M								2499	2499	2474	2474			2563	2563							
PB123	250 M	1600	740	880	1280	430	355	265	-	-	2504	2504	260	665	-	-	2551						
	280 S								-	-	2578	2578			-	-	2667						
	280 M								2654	2654	2679	2629			2718	2718							

TR KAPLİN N REDÜKTÖRLER

EN GEAR UNIT SWING-BASES WITH N COUPLINGS

DE GETRIEBESCHWINGEN MIT N KUPPLUNGEN

Tablo 4 / Table 4 / Tabelle 4															
Tip Boyut Type Size Bauart Größe	DIN 42673'e göre IEC'li motor IEC motor acc. to DIN 42673 IEC motor nach DIN 42673							Kaplin N N Coupling N Kupplung			Kaplin N Fren Tambur kaplini N Coupling with drum brake N Kupplung mit Trommelbremse				
		e	h	h1	h2	l1	b1	b2	i _N = 80 - 180	i _N = 200 - 315	b3	b4	i _N = 80 - 180	i _N = 200 - 315	
									i _N = 100 - 224	i _N = 250 - 400			i _N = 100 - 224	i _N = 250 - 400	
mm															
PB54	100 L	1000	450	515	715	205	185	115	-	1256	170	470	-	1309	
	112 M							130	1267	1262			1315	1315	
	132 S							145	1319	1314			1367	1367	
	132 M							170	1357	1352			1405	1405	
	160 M							185	1458	-			1506	-	
	160 L							170	1502	-			1550	-	
180 M	185	1524	-	1595	-										
PB64	100 L	1050	450	515	715	250	185	115	-	1336	170	470	-	1389	
	112 M							130	1347	1342			1395	1395	
	132 S							145	1399	1394			1447	1447	
	132 M							170	1437	1432			1485	1485	
	160 M							185	1538	-			1586	-	
	160 L							170	1882	-			1630	-	
180 M	185	1604	-	1675	-										
PB74	132 S	1150	540	630	880	250	215	145	-	1479	170	470	-	1552	
	132 M							170	1527	1517			1560	1560	
	160 M							170	1628	1618			1661	1661	
	160 L							185	1672	1662			1705	1705	
	180 M							185	1694	-			1750	-	
	180 L							215	1732	-			1788	-	
200 L	215	1814	-	1870	-										
PB84	132 S	1200	540	630	880	310	215	145	-	1584	170	470	-	1627	
	132 M							170	1632	1622			1665	1665	
	160 M							170	1733	1723			1766	1766	
	160 L							185	1777	1767			1810	1810	
	180 M							185	1799	-			1855	-	
	180 L							215	1837	-			1893	-	
200 L	215	1919	-	1975	-										
PB94	132 M	1350	630	720	970	300	260	145	-	1682	170	470	-	1725	
	160 M							170	-	1783			-	1826	
	160 L							170	1847	1827			1875	1870	
	180 M							185	1969	1849			1915	1915	
	180 L							215	1907	1887			1953	1953	
	200 L							215	1989	-			2035	-	
	225 S							240	2042	-			2119	-	
	225 M							240	2067	-			2144	-	
250 M	305	265	2154	-	2231	-									
PB104	132 M	1400	630	720	970	350	260	145	-	1782	170	470	-	1825	
	160 M							170	-	1883			-	1926	
	160 L							170	1947	1927			1975	1970	
	180 M							185	1969	1949			2015	2015	
	180 L							215	2007	1987			2053	2053	
	200 L							215	2089	-			2135	-	
	225 S							240	2142	-			2219	-	
	225 M							240	2167	-			2244	-	
250 M	305	265	2254	-	2331	-									
PB114	160 L	1550	740	880	1280	345	270	170	-	2062	170	470	-	2090	
	180 M							185	-	2084			-	2130	
	180 L							215	2142	2122			2173	2168	
	200 L							215	2224	2204			2255	2250	
	225 S						240	2277	2257	2334	2334				
	225 M						240	2302	-	2359	-				
	250 M						265	2389	-	2446	-				
	280 S						355	2463	-	2562	-				
280 M	300	2514	-	2613	-										
PB124	160 L	1600	740	880	1280	430	270	170	-	2217	170	470	-	2245	
	180 M							185	-	2239			-	2285	
	180 L							215	2297	2277			2328	2323	
	200 L							215	2379	2359			2410	2405	
	225 S						240	2432	2412	2489	2489				
	225 M						240	2457	-	2514	-				
	250 M						265	2544	-	2601	-				
	280 S						355	2618	-	2717	-				
280 M	300	2669	-	2768	-										

1) Talep edildiğinde.

2) Fanlı redüktörler için I2, I3

Redüktör titreşim tabanının ağırlığı, talep edildiğinde temin edilir.

1) On request

2) I2, I3 for gear units with fan

Weight of gear unit swing - base on request

1) Auf Anfrage

2) I2, I3 für Getriebe mit Lüfter

Gewicht der Getriebeschwinge auf Anfrage

TR

KAPLIN N REDÜKTÖRLER

EN

GEAR UNIT SWING-BASES WITH
N COUPLINGS

DE

GETRIEBESCHWINGEN MIT
N KUPPLUNGEN

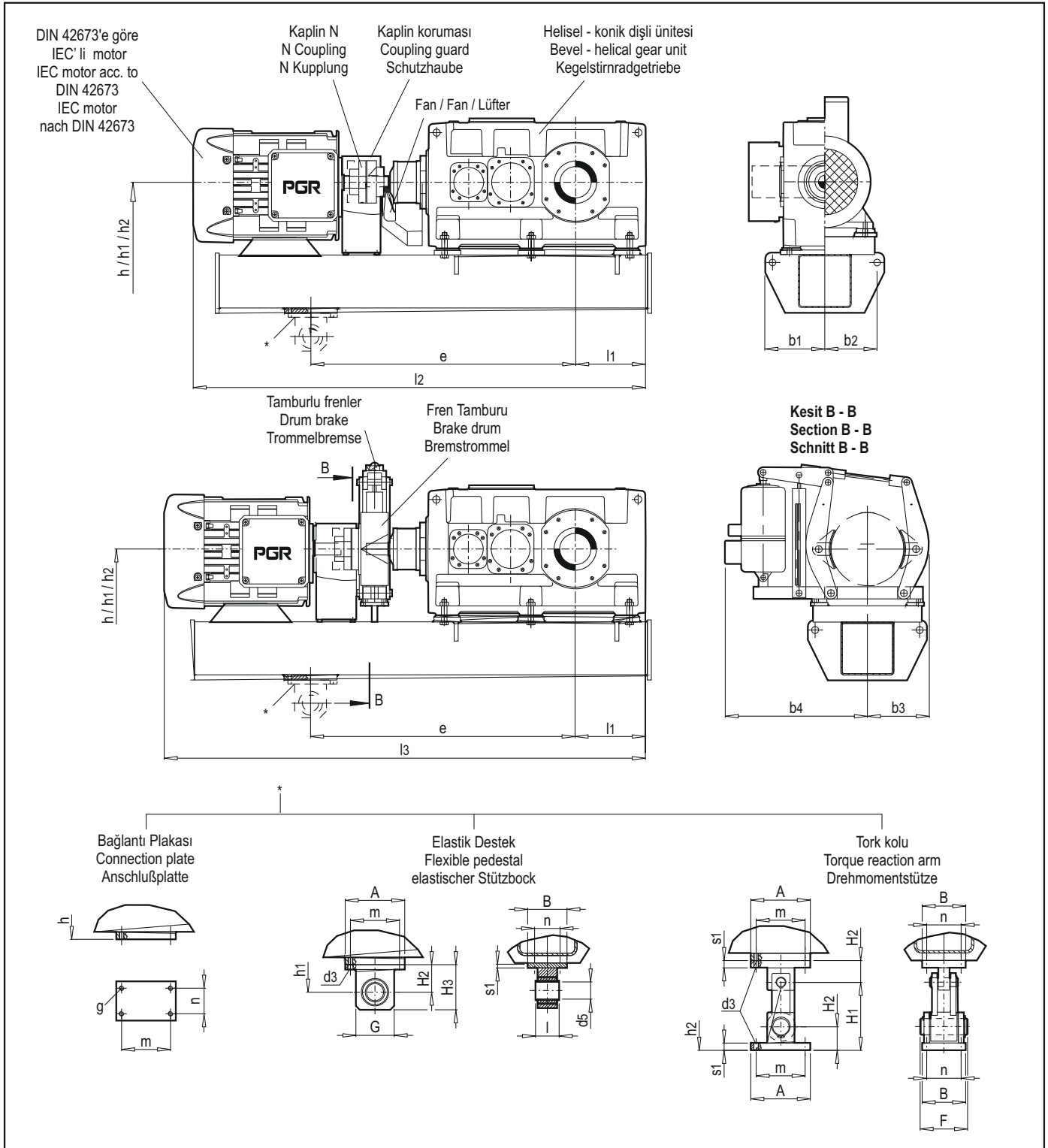

Tablo 5 / Table 5 / Tabelle 5

Gövde Size Größe	Burç Bush Buchse	mm														Ağırlık / Weight / Gewicht	
		m	n	g	Ød3	A	B	Ød5	f	G	H1	H2	H3	l	s1	Destek Pedestal Stützbock	Torkolları Torque reaction arm Drehmomentstütze
															kg	kg	
13... / 14...	772	260	130	Ø19	19	320	200	100	195	180	400	140	230	120	25	50	82
15... / 18...	805	320	240	Ø24	24	400	300	124	320	240	500	175	285	230	30	95	220

TR

KAPLİN N REDÜKTÖRLER

EN

GEAR UNIT SWING-BASES WITH
N COUPLINGS

DE

GETRIEBESCHWINGEN MIT
N KUPPLUNGEN

Tablo / Table / Tabelle 6																		
Tip Gövde Type Size Bauart Größe	DIN 42673'e göre IEC'li motor IEC motor acc. to DIN 42673 IEC motor nach DIN 42673	Kaplin N N Coupling N Kupplung										Kaplin N Fren Tambur kaplini N Coupling with drum brake N Kupplung mit Trommelbremse						
		e	h	h1	h2	l1	b1	b2	İN = 12.5 - 45		İN = 50 - 71		b3	b4	İN = 12.5 - 45		İN = 50 - 71	
									İN = 16 - 56		İN = 63 - 90				İN = 16 - 56		İN = 63 - 90	
		l2 ²⁾		l2 ²⁾		l3 ²⁾		l3 ²⁾										
mm																		
PB133	280 M						300	-	-	2729	2729			-		2788		
PB143	280 M						300	-	-	2869	2869			-		2928		

1) Talep edildiğinde.

2) Fanlı redüktörler için l2*, l3*

Redüktör taban şasesinin ağırlığı, talep üzerine temin edilir.

1) On request

2) l2*, l3* for gear units with fan

Weight of gear unit swing - base on request

1) Auf Anfrage

2) l2*, l3* für Getriebe mit Lüfter

Gewicht der Getriebeschwinge auf Anfrage

Tablo 7 / Table 7 / Tabelle / 7														
Tip Gövde Type Size Bauart GröÙe	DIN 42673'e göre IEC'li motor IEC motor acc. to DIN 42673 IEC motor nach DIN 42673							Kaplin N N Coupling N Kupplung			Kaplin N Fren Tambur Kaplini N Coupling with drum brake N Kupplung mit Trommelbremse			
		e	h	h1	h2	l1	b1	b2	iN=80-180	iN=200-315	b3	b4	iN=80-180	iN=200-315
									iN=100-224	iN=250-400			iN=100-224	iN=250-400
									iN=90-200	iN=224-355			iN=90-200	iN=224-355
mm														
PB134	180 M	1750	800	940	1340	405	345	185	-	2324	210	590	-	2355
	180 L							-	2362	-			2393	
	200 L							-	2444	-			2475	
	225 S							2507	2497	2554			2554	
	225 M							2532	2522	2579	2579			
	250 M							2619	2609	2666	2666			
	280 S							2693	-	2782	-			
	280 M							2744	-	2833	-			
PB144	180 M	1750	800	940	1340	475	345	185	-	2464	210	590	-	2495
	180 L							-	2502	-			2533	
	200 L							-	2584	-			2615	
	225 S							2647	2637	2694			2694	
	225 M							2672	2662	2719	2719			
	250 M							2759	2749	2806	2806			
	280 S							2833	-	2922	-			
	280 M							2884	-	2973	-			
PB154	200 L	2000	975	1150	1650	485	345	215	-	2766	210	590	-	2797
	225 S							-	2819	-			2866	
	225 M							-	2844	260	665	-	2891	
	250 M							2956	2931			2995	2978	
	280 S							3030	3005	310	765	3111	3094	
	280 M							3081	3056			3145	3145	
PB164	200 L	2000	975	1150	1650	530	345	215	-	2857	210	590	-	2888
	225 S							-	2910	-			2957	
	225 M							-	2935	260	665	-	2982	
	250 M							3047	3022			3086	3069	
	280 S							3121	3096	310	765	3202	3185	
	280 M							3172	3147			3236	3236	
PB174	225 M	2200	1025	1200	1700	525	500	240	-	2932	260	665	-	2979
	250 M							-	3019	-			3066	
	280 S							3118	3093	310	765	3199	3182	
	280 M							3169	3144			3233	3233	
PB184	225 M	2200	1025	1200	1700	525	500	240	-	3052	260	665	-	3099
	250 M							-	3139	-			3186	
	280 S							3238	3213	310	765	3319	3302	
	280 M							3289	3264			3353	3353	

1) Talep edildiğinde.

2) Fanlı redüktörler için I2*, I3*

Redüktör taban şasesinin ağırlığı, talep üzerine temin edilir.

1) On request

2) I2*, I3* for gear units with fan

Weight of gear unit swing - base on request

1) Auf Anfrage

2) I2*, I3* für Getriebe mit Lüfter

Gewicht der Getriebeschwinge auf Anfrage

TR KAPLİN F, IEC-MOTORLU, KAPLİN BAĞLANTILI VE FRENLİ REDÜKTÖRLER

EN GEAR UNIT SWING-BASES WITH F COUPLINGS, IEC MOTORS AND ASSIGNED COUPLINGS AND BRAKES

DE GETRIEBESCHWINGEN MIT F KUPPLUNGEN, IEC-MOTOREN UND ZUGEORDNETEN KUPPLUNGEN UND BREMSSEN

Tablo 8 / Table 8 / Tabelle 8

DIN 42673'e göre IEC'li motor IEC motor acc. to DIN 42673 IEC motor nach DIN 42673	KAPLİN F / F COUPLINGS / F KUPPLUNGEN- 3) Ön hücreli kaplin, Harekete geçme faktörü 2 Coupling without delay chamber, starting factor 2 Kupplung ohne Vorkammer, Anfahrfaktor 2			KAPLİN F / F COUPLINGS / F KUPPLUNGEN- 3) Ön hücreli kaplin, Harekete geçme faktörü 1.5 Coupling with delay chamber, starting factor 1.5 Kupplung mit Vorkammer, Anfahrfaktor 1.5		
	Tip / Gövde Type / Size Bauart / Größe	Kaplin F Tipi - boyutu F Coupling Type / Size F Kupplung Bauart / Größe	Tambur Freninin Boyutu Drum brake size Trommelbremse Größe	Tip / Gövde Type / Size Bauart / Größe	Kaplin F Tipi - boyutu F Coupling Type / Size F Kupplung Bauart / Größe	Tambur Freninin Boyutu Drum brake size Trommelbremse Größe
1500-1min						
100	FAD 222	FADB 222	TE 200			
112	FAD 222	FADB 222	TE 200			
132 S	FAD 222	FADB 222	TE 200			
132 M	FAD 297	FADB 297	TE 200			
160	FAD 297	FADB 297	TE 200	FND 370	FNDB 370	TE 315
180 M	FAD 297	FADB 297	TE 250	FND 370	FNDB 370	TE 315
180 L	FAD 342	FADB 342	TE 250	FND 370	FNDB 370	TE 315
200	FAD 342	FADB 342	TE 250	FND 370	FNDB 370	TE 315
225	FAD 395	FADB 395	TE 315	FND 370	FNDB 370	TE 315
250	FAD 395	FADB 395	TE 315	FND 425	FNDB 425	TE 315
280	FAD 450	FADB 450	TE 315	FND 425	FNDB 425	TE 315
315 S	FAD 516	FADB 516	TE 400	FND 490	FNDB 490	TE 400
315 M	FAD 516	FADB 516	TE 400	FND 490	FNDB 490	TE 400

 3) EOC-Devre kesicisi, talep üzerine temin edilir.
 Fren diskli Kaplin F, sadece talep üzerine temin edilir.

 3) EOC circuit breaker on request
 F Couplings with brake disk on request

 3) EOC- Abschaltung auf Anfrage
 F - Kupplungen mit Bremsscheibe auf Anfrage

TR KAPLİN F, IEC-MOTORLU, KAPLİN BAĞLANTILI VE FRENLİ REDÜKTÖRLER

EN GEAR UNIT SWING-BASES WITH F COUPLINGS, IEC MOTORS AND ASSIGNED COUPLINGS AND BRAKES

DE GETRIEBESCHWINGEN MIT F KUPPLUNGEN, IEC-MOTOREN UND ZUGEORDNETEN KUPPLUNGEN UND BREMSEN

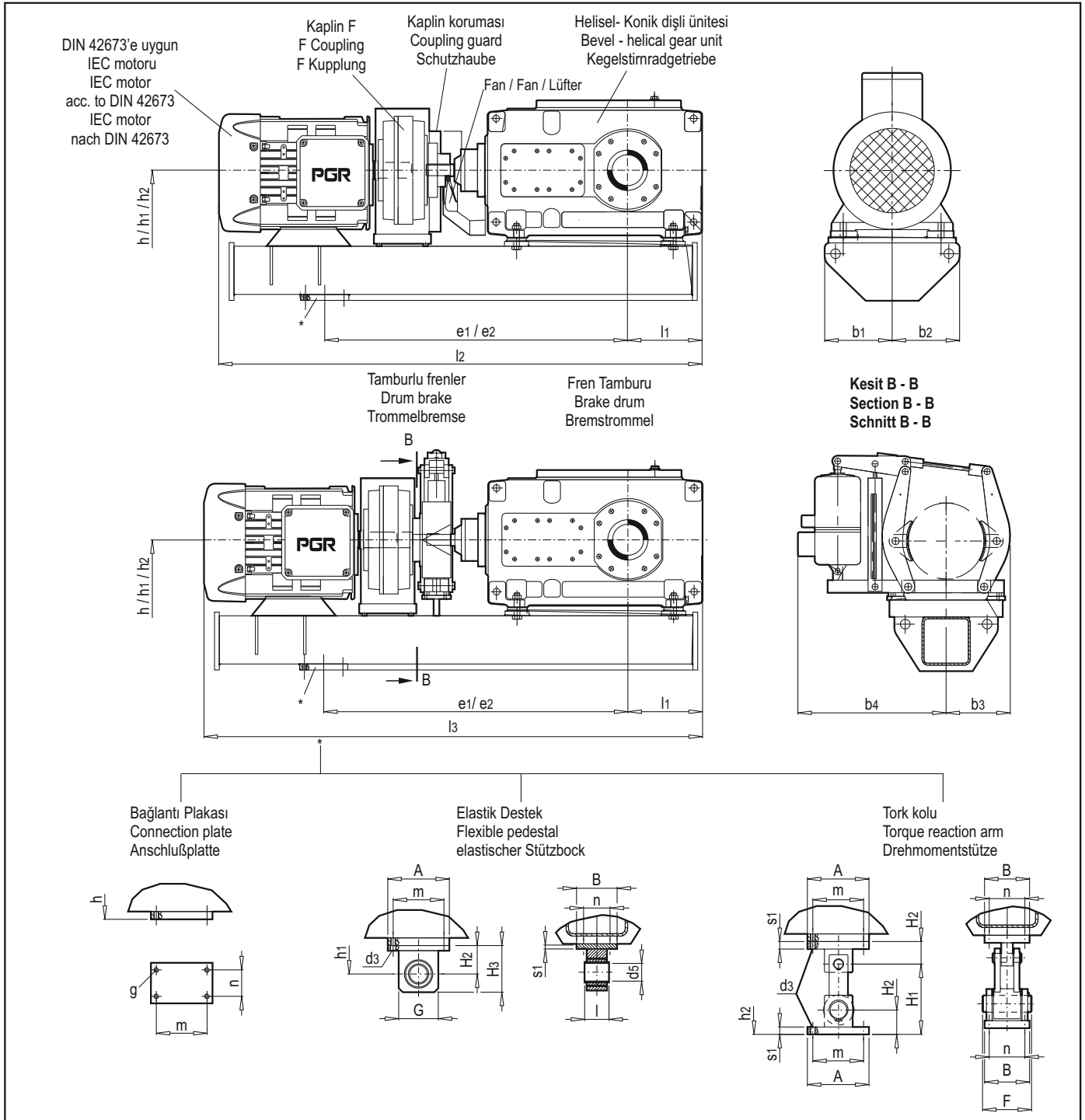

Tablo 9 / Table 9 / Tabelle 9

Gövde Size Größe	Burç Bush Buchse	mm															Ağırlık / Weight / Gewicht	
		m	n	g	Ød3	A	B	Ød5	F	G	H1	H2	H3	l	s1	Destek Pedestal Stützbock kg	Dönme momenti destekleri Torque reaction arm Drehmomentstütze kg	
4...	069	95	65	M 12	15	120	90	25	96	60	180	50	80	56	12	2.1	5.8	
5... / 6...	079	120	70	M 16	19	160	110	32	116	75	200	65	105	72	15	5.3	11.8	
7... / 10...	095	160	120	M 16	19	200	160	50	170	110	250	90	145	110	20	16	34	
11... / 12...	772	260	130	M 16	19	320	200	100	195	180	400	140	230	120	25	50	82	

TR KAPLIN F BAĞLANTILI REDÜKTÖRLER

EN GEAR UNIT SWING-BASES WITH F FLUID COUPLINGS

DE GETRIEBESCHWINGEN MIT F STROMUNGSKUPPLUNGEN

Tablo 10 / Table 10 / Tabelle 10																											
Tip Gövde Type Size Bauart Größe	DIN 42673'e göre IEC'li motor IEC motor acc. to DIN 42673 IEC motor nach DIN 42673											Kaplin F F Coupling F Kupplung								Kaplin F - Fren Tambur kaplini F - Coupling with drum brake F - Kupplung mit trommelbremse							
		e1 ⁶⁾	e2 ⁶⁾	h	h1	h2	l1	b1	b2	İN = 12.5 - 45				İN = 50 - 71				b3 ⁵⁾	b4 ⁵⁾	İN = 12.5 - 45				İN = 50 - 71			
										İN = 16 - 56				İN = 63 - 90						İN = 16 - 56				İN = 63 - 90			
										fA = 2 4)		fA = 1.5 4)		fA = 2 4)		fA = 1.5 4)				fA = 2 4)		fA = 1.5 4)		fA = 2 4)		fA = 1.5 4)	
l2 2)		l2*2)		l2 2)		l2*2)		l2 2)		l2*2)		l2 2)		l2*2)		l2 2)		l2*2)		l2 2)		l2*2)					
mm																											
PB43	132 S	950	1250	380	430	610	190	160	145	-	-	-	-	1251	1243	-	-	170	470	-	-	1283	-				
	132 M								-	-	-	-	1342	1328	-	-	-			-	1368	-					
	160 M								1413	1413	-	-	1403	1413	-	-	1439			-	1439	-					
	160 L								1457	1457	-	-	1447	1457	-	-	1483			-	1483	-					
	180 M								1444	1479	-	-	1464	1469	-	-	1505			-	1505	-					
	180 L								1550	1555	-	-	-	-	-	-	1601			-	-	-					
	200 L								1632	1637	-	-	-	-	-	-	1683			-	-	-					
PB53	160 M	1050	1300	450	515	715	205	185	170	-	-	-	-	1493	1503	1704	1724	170	470	-	-	1529	1791				
	160 L								1557	1557	1758	1768	1537	1587	1748	1768	1578			1835	1573	1835					
	180 M								1576	1574	1780	1790	1554	1569	1770	1790	1595			1857	1595	1857					
	180 L								1650	1650	1818	1828	1630	1645	1808	1828	1691			1895	1691	1895					
	200 L								1732	1732	1900	1910	-	-	-	-	1773			1977	-	-					
	225 S								1)	1)	1922	1932	-	-	-	-	1)			1999	-	-					
	225 M								1)	1)	1947	1957	-	-	-	-	1)			2024	-	-					
PB63	160 M	1100	1350	450	515	715	250	185	170	-	-	-	-	1573	1583	1784	1804	170	470	-	-	1609	1871				
	160 L								1635	1637	1838	1848	1617	1627	1828	1848	1658			1915	1653	1915					
	180 M								1654	1654	1860	1870	1634	1649	1850	1870	1675			1937	1675	1937					
	180 L								1730	1730	1898	1908	1710	1725	1888	1908	1771			1975	1771	1975					
	200 L								1812	1812	1980	1990	-	-	-	-	1853			2057	-	-					
	225 S								1)	1)	2002	2012	-	-	-	-	1)			2079	-	-					
	225 M								1)	1)	2027	2037	-	-	-	-	1)			2104	-	-					
PB73	180 M	1250	1450	540	630	880	250	215	185	-	-	-	-	1734	1734	1940	1950	210	590	-	-	1755	2017				
	180 L								-	-	-	-	1810	1810	1978	1988	-			-	1851	2055					
	200 L								1912	1912	2080	2080	1892	1992	2060	2070	1938			2137	1933	2137					
	225 S								1928	1938	2102	2102	1918	1938	2082	2092	1981			2159	1981	2159					
	225 M								1953	1963	2127	2127	1943	1963	2107	2117	2006			2184	2006	2184					
	250 M								2040	2050	2271	2271	-	-	-	-	2093			2333	-	-					
	280 S								2142	2162	2345	2345	-	-	-	-	2199			2407	-	-					
280 M	1)	1)	2396	2396	-	-	-	-	1)	2458	-	-															
PB83	180 M	1300	1500	540	630	880	310	215	185	-	-	-	-	1839	1839	2045	2055	210	590	-	-	1860	2122				
	180 L								-	-	-	-	1915	1815	2083	2093	-			-	1956	2160					
	200 L								2017	2017	2185	2185	1997	1997	2165	2145	2043			2242	2038	2242					
	225 S								2033	2043	2207	2207	2023	2043	2187	2197	2086			2264	2086	2264					
	225 M								2058	2068	2232	2232	2048	2068	2212	2222	2111			2289	2111	2289					
	250 M								2145	2155	2376	2376	-	-	-	-	2198			2438	-	-					
	280 S								2247	2267	2450	2450	-	-	-	-	2304			2512	-	-					
280 M	1)	1)	2501	2501	-	-	-	-	1)	2563	-	-															
PB93	200 L	1450	1650	630	720	970	300	260	215	-	-	-	-	2072	2072	2240	2240	210	590	-	-	2098	2297				
	225 S								-	-	-	-	2088	2108	2262	2262	-			-	2141	2319					
	225 M								2123	2133	2297	2297	2113	2133	2287	2287	2166			2344	2166	2344					
	250 M								2210	2220	2441	2441	2200	2220	2431	2441	2253			2493	2253	2493					
	280 S								2312	2332	2515	2515	2302	2332	2505	2515	2359			2567	2359	2567					
	280 M								2363	2383	2566	2566	-	-	-	-	2410			2618	-	-					
	200 L								215	-	-	-	-	2172	2172	2340	2340			210	590	-	-	2198	2397		
225 S	240	-	-	-	-	2188	2208	2362	2362	-	-	-	-	2241	2419												
225 M	2223	2233	2397	2397	2213	2233	2387	2387	2266	2444	2266	2444															
250 M	265	2310	2320	2541	2541	2300	2320	2531	2541	260	665	2353	2593	2353	2593												
280 S	300	2412	2432	2615	2615	2402	2432	2605	2615	2459	2667	2459	2667														
280 M	2463	2483	2666	2666	-	-	-	-	2510	2718	-	-															
PB113	250 M	1650	1900	740	880	1280	345	355	265	-	-	-	-	2415	2425	2646	2646	260	665	-	-	2458	2698				
	280 S								-	-	-	-	2517	2537	2720	2720	-			-	2564	2772					
	280 M								2593	2593	2796	2796	2568	2588	2771	2771	2632			2840	2615	2823					
PB123	250 M	1700	1950	740	880	1280	430	355	265	-	-	-	-	2570	2580	2801	2801	260	665	-	-	2613	2853				
	280 S								-	-	-	-	2672	2692	2875	2875	-			-	2719	2927					
	280 M								2748	2748	2951	2951	2723	2743	2926	2926	2787			2995	2770	2978					

TR KAPLIN F BAĞLANTILI REDÜKTÖRLER

EN GEAR UNIT SWING-BASES WITH F FLUID COUPLINGS

DE GETRIEBESCHWINGEN MIT F - STRÖMUNGSKUPPLUNGEN

Tablo 11 / Table 11 / Tabelle 11

Tip Gövde Type Size Bauart Größe	DIN 42673'e göre IEC'li motor IEC motor acc. to DIN 42673 IEC motor nach DIN 42673	Kaplın F F Coupling F Kupplung							Kaplın F - Fren Tambur Kaplini F - Coupling with drum brake F - Kupplung mit trommelbremse										
		e1 ⁶⁾ e2 ⁶⁾	h	h1	h2	l1	b1	b2	İN = 80 - 180		İN = 200 - 315		b3 ⁵⁾ b4 ⁵⁾	İN = 80 - 180		İN = 200 - 315			
									İN = 100 - 224	İN = 250 - 400	İN = 100 - 224	İN = 250 - 400		fA = 2 4)	fA = 1.5 4)	fA = 2 4)	fA = 1.5 4)	fA = 2 4)	fA = 1.5 4)
PB54	100 L	950	1250	450	515	715	205	185	115	-	-	1338	-	170	470	-	-	1375	-
	130								1349	-	1344	-	1386			-	1381	-	
	145								1376	-	1371	-	1413			-	1413	-	
	170								1467	-	1462	-	1498			-	1498	-	
	170								1528	1744	-	-	1569			1831	-	-	
	170								1572	1788	-	-	1613			1875	-	-	
	185								1589	1810	-	-	1635			1897	-	-	
PB64	100 L	1000	1300	450	515	715	250	185	115	-	-	1418	-	170	470	-	-	1455	-
	130								1429	-	1424	-	1466			-	1461	-	
	145								1456	-	1451	-	1493			-	1493	-	
	170								1547	-	1542	-	1578			-	1578	-	
	170								1626	1824	-	-	1649			1911	-	-	
	170								1652	1868	-	-	1693			1955	-	-	
	185								1669	1890	-	-	1715			1977	-	-	
PB74	132 S	1050	1350	540	630	880	250	215	145	-	-	1536	-	170	470	-	-	1568	-
	170								1637	-	1627	-	1670			-	1653	-	
	170								1698	1899	1688	1899	1724			1986	1724	1986	
	185								1742	1943	1732	1943	1768			2030	1768	2030	
	185								1759	1965	-	-	1790			2052	-	-	
	210								1835	2003	-	-	1886			2090	-	-	
	215								1917	2085	-	-	1968			2172	-	-	
PB84	132 S	1100	1400	540	630	880	310	215	145	-	-	1641	-	170	470	-	-	1673	-
	170								1742	-	1732	-	1775			-	1758	-	
	170								1803	2004	1793	2004	1829			2091	1829	2091	
	185								1847	2048	1837	2048	1873			2135	1873	2135	
	185								1864	2070	-	-	1895			2157	-	-	
	210								1940	2108	-	-	1991			2195	-	-	
	215								2022	2190	-	-	2073			2277	-	-	
PB94	132 M	1250	1500	630	720	970	300	260	145	-	-	1792	-	170	470	-	-	1818	-
	170								1897	2118	1897	2108	1938			2195	1933	2195	
	185								1914	2140	1914	2130	1955			2217	1955	2217	
	210								1990	2178	1990	2168	2051			2255	2051	2255	
	215								2072	2260	-	-	2133			2337	-	-	
	240								2118	2282	-	-	2181			2359	-	-	
	305								2143	2307	-	-	2206			2384	-	-	
PB104	132 M	1300	1550	630	720	970	350	260	145	-	-	1892	-	170	470	-	-	1918	-
	170								1997	2218	1997	2208	2038			2295	2033	2295	
	185								2014	2240	2014	2230	2055			2317	2055	2317	
	210								2090	2278	2090	2268	2151			2355	2151	2355	
	215								2172	2360	-	-	2233			2437	-	-	
	240								2218	2382	-	-	2281			2459	-	-	
	305								2243	2407	-	-	2306			2484	-	-	
PB114	160 L	1450	1650	740	880	1280	345	270	170	-	-	2132	2333	170	470	-	-	2153	2410
	185								-	-	2149	2355	-			-	2170	2432	
	210								2245	2413	2225	2393	2271			2470	2266	2470	
	215								2227	2495	2307	2475	2353			2552	2348	2552	
	240								2343	2517	2332	2497	2396			2574	2395	2574	
	260								2368	2542	-	-	2421			2599	-	-	
	355								2455	2686	-	-	2508			2748	-	-	
PB124	160 L	1500	1700	740	880	1280	430	270	170	-	-	2287	2488	170	470	-	-	2308	2565
	185								-	-	2306	2510	-			-	2325	2587	
	210								2400	2568	2380	2548	2426			2625	2421	2625	
	215								2482	2650	2462	2630	2508			2707	2503	2707	
	240								2498	2672	2487	2652	2551			2729	2550	2729	
	260								2523	2697	-	-	2576			2754	-	-	
	355								2610	2841	-	-	2663			2903	-	-	
300	2712	2915	-	-	2769	2977	-	-											
310	2763	2966	-	-	2820	3028	-	-											

1) Talep üzerine temin edilir.
 2) Fanlı redüktörler için I2, I3. Fanlı ve tambur frenli redüktörler, talep üzerine yapılmaktadır.
 4) fA = Harekete geçme faktörü
 5) fA = 2 için; fA=1.5 için 225 S ve üstü motor büyüklükleri; 200L motor büyüklüğüne kadar fA=1.5: b3 = 260 mm, b4 = 610 mm
 6) Ön hücreli kaplin F için e1 ölçüsü (fA=2);
 Ön hücreli, tambur frenli kaplin F için e1 ölçüsü (fA=1.5);
 Ön hücreli kaplin F için e2 ölçüsü (fA=1.5);
 Ön hücreli, tambur frenli kaplin F için e2 ölçüsü (fA=1.5);
 Redüktör taban şasesinin ağırlığı, talep üzerine temin edilir.

1) On request
 2) I2* for gear units with fan. Gear units with fan and drum brake on request
 4) fA = starting factor
 5) For fA = 2; for fA = 1.5 from motor size 225 S up; fA= 1.5 up to motor size 200 L: b3 = 260 mm, b4 = 610 mm
 6) e1 dimension for F coupling without delay chamber (fA = 2);
 F coupling without delay chamber with drum brake (fA = 2);
 e2 dimension for F coupling with delay chamber (fA = 1.5)
 F coupling with delay chamber and drum brake (fA = 1.5);
 Weight of gear unit swing- base on request

1) Auf Anfrage
 2) I2 für Getriebe mit Lüfter. Getriebe mit Lüfter und Trommelbremse auf Anfrage.
 4) fA = Anfahrfaktor
 5) Für fA = 2, für fA=1.5 ab Motorgröße 225 S; fA = 1.5 bis Motorgröße 200 L :
 b3 = 260 mm, b4 = 610 mm
 6) e1-Maß für F - Kupplung ohne Vorkammer (fA=2);
 F - Kupplung ohne Vorkammer mit Trommelbremse (fA=2);
 e2- Maß für F-Kupplung mit Vorkammer (fA=1.5);
 F-Kupplung mit Vorkammer und Trommelbremse (fA=1.5);
 Gewicht der Getriebeschwinde auf Anfrage

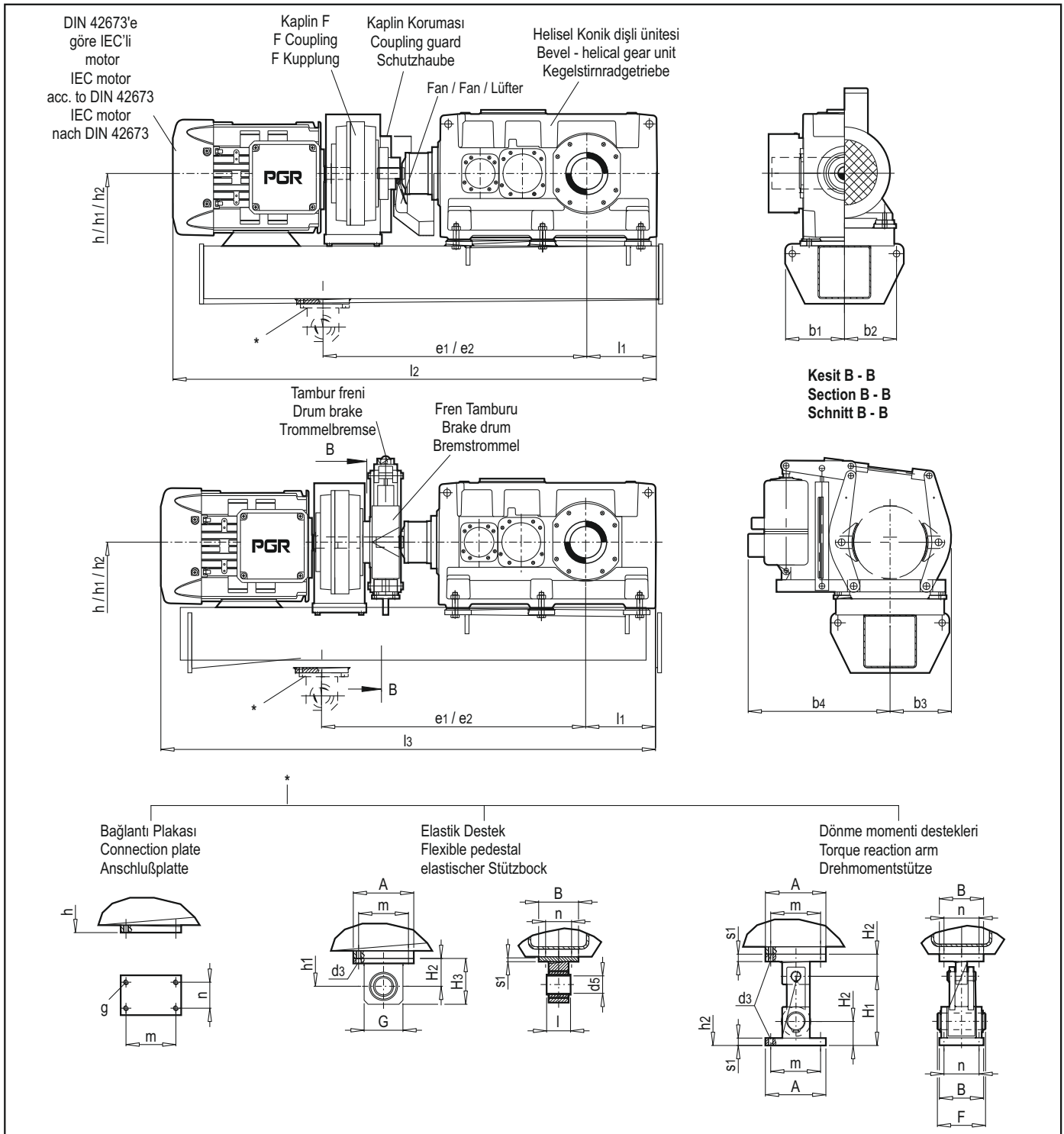

Tablo 12 / Table 12 / Tabelle 12

Gövde Size Größe	Burç Bush Buchse	mm														Ağırlık / Weight / Gewicht	
		m	n	g	Ød3	A	B	Ød5	F	G	H1	H2	H3	l	s1	Destek Pedestal Stützbock	Torkolları Torque reaction arm Drehmomentstütze
																kg	kg
13...-14...	772	260	130	Ø19	19	320	200	100	195	180	400	140	230	120	25	50	82
15...-18...	805	320	240	Ø24	24	400	300	124	320	240	500	175	285	230	30	95	220

TR KAPLİN F BAĞLANTILI REDÜKTÖRLER

EN GEAR UNIT SWING-BASES WITH F FLUID COUPLINGS

DE GETRIEBESCHWINGEN MIT F - STRÖMUNGSKUPPLUNGEN

Tablo 13 / Table 13 / Tabelle 13

Tip Gövde Type Size Bauart Größe	DIN 42673'e göre IEC'li motor acc. to DIN 42673 IEC motor nach DIN 42673	Kaplin F F Coupling F Kupplung														Kaplin F - Fren Tambur kaplini F - Coupling with drum brake F - Kupplung mit trommelbremse							
									İN = 12.5 - 45				İN = 50 - 71						İN = 12.5 - 45		İN = 50 - 71		
									İN = 16 - 56				İN = 63 - 90						İN = 16 - 56		İN = 63 - 90		
									fA=2 4)		fA=1.5 4)		fA=2 4)		fA=1.5 4)				fA=2 4)	fA=1.5 4)	fA=2 4)	fA=1.5 4)	
e1 ⁶⁾ e2 ⁶⁾ h h1 h2 l1 b1		b2	l2 ²⁾ l2* ²⁾	l2 ²⁾ l2* ²⁾	l2 ²⁾ l2* ²⁾	l2 ²⁾ l2* ²⁾	mm				b3 ⁵⁾ b4 ⁵⁾	l3 ²⁾ l3 ²⁾	l3 ²⁾ l3 ²⁾	l3 ²⁾ l3 ²⁾	l3 ²⁾ l3 ²⁾								
PB133	280 M	1900	2150	800	940	1340	405	345	300	-	-	-	-	2823	2823	3026	3026	260	665	-	-	2862	3070
PB143	280 M	1900	2150	800	940	1340	475	345	300	-	-	-	-	2963	2963	3166	3166	260	665	-	-	3002	3210

TR KAPLİN F BAĞLANTILI REDÜKTÖRLER

EN GEAR UNIT SWING-BASES WITH F FLUID COUPLINGS

DE GETRIEBESCHWINGEN MIT F - STRÖMUNGSKUPPLUNGEN

Tablo 14 / Table 14 / Tabelle 14																			
Tip Gövde Type Size Bauart Größe	DIN 42673'e göre IEC'li motor IEC motor acc. to DIN 42673 IEC motor nach DIN 42673	Kaplın F F Coupling F Kupplung										Kaplın F - Fren Tambur Kaplini F - Coupling with drum brake F - Kupplung mit trommelbremse							
		e1 ⁶⁾	e2 ⁶⁾	h	h1	h2	l1	b1	b2	İN = 80 - 180		İN = 200 - 315		b3 ⁵⁾	b4 ⁵⁾	İN = 80 - 180		İN = 200 - 315	
										İN = 100 - 224		İN = 250 - 400				İN = 100 - 224		İN = 250 - 400	
										İN = 90 - 200		İN = 224 - 355				İN = 90 - 200		İN = 224 - 355	
fA = 2 4)		fA = 1.5 4)		fA = 2 4)		fA = 1.5 4)		fA = 2 4)		fA = 1.5 4)		fA = 2 4)		fA = 1.5 4)					
mm																			
PB134	180 M	1700	1900	800	940	1340	405	345	185	-	-	2389	2595	210	590	-	-	2395	2652
	180 L									-	-	2465	2633			-	-	2491	2690
	200 L									-	-	2547	2715			-	-	2573	2772
	225 S									2572	2747	2562	2737			2615	2794	2615	2794
	225 M									2597	2772	2587	2762			2640	2819	2640	2819
	250 M									2684	2916	2674	2906			2727	2968	2727	2968
	280 S									2787	2990	-	-			2834	3042	-	-
	280 M									2838	3041	-	-			2885	3093	-	-
PB144	180 M	1700	1900	800	940	1340	475	345	185	-	-	2529	2735	210	590	-	-	2535	2792
	180 L									-	-	2605	2773			-	-	2631	2830
	200 L									-	-	2687	2855			-	-	2713	2912
	225 S									2712	2887	2702	2877			2755	2934	2755	2934
	225 M									2737	2912	2727	2902			2780	2959	2780	2959
	250 M									2824	3056	2814	3046			2867	3108	2867	3108
	280 S									2927	3130	-	-			2974	3182	-	-
	280 M									2978	3181	-	-			3025	3233	-	-
PB154	200 L	2000	2200	975	1150	1650	485	345	215	-	-	2869	3037	210	590	-	-	2895	3084
	225 S									-	-	2884	3059			-	-	2927	3106
	225 M									-	-	2909	3084			-	-	2952	3131
	250 M									3021	3253	2996	3228			3056	3297	3039	3280
	280 S									3124	3327	3099	3302			3163	3371	3146	3354
	280 M									3175	3378	3150	3353			3214	3422	3197	3405
PB164	200 L	2000	2200	975	1150	1650	530	345	215	-	-	2960	3128	210	590	-	-	2986	3175
	225 S									-	-	2975	3150			-	-	3018	3197
	225 M									-	-	3000	3175			-	-	3043	3222
	250 M									3112	3344	3087	3319			3147	3388	3130	3371
	280 S									3215	3418	3190	3393			3254	3462	3237	3445
	280 M									3266	3469	3241	3444			3305	3513	3288	3496
PB174	225 M	2200	2400	1025	1200	1700	525	500	240	-	-	2997	3172	260	665	-	-	3040	3219
	250 M									-	-	3084	3316			-	-	3127	3368
	280 S									3212	3415	3187	3390			3251	3459	3234	3442
	280 M									3263	3466	3238	3441			3302	3510	3285	3493
PB184	225 M	2200	2400	1025	1200	1700	585	500	240	-	-	3117	3292	260	665	-	-	3160	3339
	250 M									-	-	3204	3436			-	-	3247	3488
	280 S									3332	3535	3307	3510			3371	3579	3354	3562
	280 M									3383	3586	3358	3561			3422	3630	3405	3613

1) Talep üzerine temin edilir.

2) Fanlı redüktörler için I2, I3. Fanlı ve tambur frenli redüktörler, talep üzerine yapılmaktadır.

4) fA = Harekete geçme faktörü

5) fA = 2 için; fA=1.5 için 225 S ve üstü motor büyüklükleri; 200L motor büyüklüğüne kadar fA=1.5: b3 = 260 mm, b4 = 610 mm

6) Ön hücreli kaplin F için e1 ölçüsü (fA=2);

Ön hücreli, tambur frenli kaplin F için e1 ölçüsü (fA=1.5);

Ön hücreli kaplin F için e2 ölçüsü (fA=1.5);

Ön hücreli, tambur frenli kaplin F için e2 ölçüsü (fA=1.5);

Redüktör taban şasesinin ağırlığı, talep üzerine temin edilir.

1) On request

2) I2* for gear units with fan. Gear units with fan and drum brake on request

4) fA = starting factor

5) For fA = 2; for fA = 1.5 from motor size 225 S up; fA=1.5 up to motor size 200 L: b3 = 260 mm, b4 = 610 mm

6) e1 dimension for F coupling without delay chamber (fA = 2);

F coupling without delay chamber with drum brake (fA=2);

e2 dimension for F coupling with delay chamber (fA=1.5);

F coupling with delay chamber and drum brake (fA = 1.5);

Weight of gear unit swing- base on request

1) auf Anfrage

2) I2 für Getriebe mit Lüfter. Getriebe mit Lüfter und Trommelbremse auf Anfrage.

4) fA = Anfahrfaktor

5) Für fA=2, für fA=1.5 ab Motorgröße 225 S; fA = 1.5 bis Motorgröße 200 L :

b3 = 260 mm, b4 = 610 mm

6) e1-Maß für F-Kupplung ohne Vorkammer (fA=2);

F-Kupplung ohne Vorkammer mit Trommelbremse

(fA=2); e2- Maß für F-Kupplung mit Vorkammer (fA=1.5);

F-Kupplung mit Vorkammer und Trommelbremse (fA=1.5);

Gewicht der Getriebeschwinge auf Anfrage

TR

ÖZEL MONTAJ POZİSYONLARI

EN

SPECIAL MOUNTING POSITIONS

DE

SONDEREINBAULAGEN

Çizimleri aşağıda gösterilen özel montaj pozisyonları için, PGR dişli redüktörlerinin PH...2, PH...3, PH...4, PB...2, PB...3 ve PB...4 tipi imalat modelleri de, mevcuttur.

Kurulum, örneğin mil montajlı redüktörlerde tork kolu veya ayak/tabana ayakları vasıtasıyla yapılır.

PGR - Gear units of types PH...2, PH...3, PH...4, PB...2, PB...3 and PB...4 ...are also available for the special mounting positions illustrated below.

They can be installed, for example, as shaft-mounted gear unit with torque reaction arm or by means of base rails.
For oil supply, take into account table 2.

PGR - Zahnradgetriebe der Bauarten PH...2, PH...3, PH...4, PB...2, PB...3 und PB...4 sind auch für nachstehende Sondereinbautagen lieferbar

Die Aufstellung kann z.B. als Aufsteckgetriebe mit Drehmomentstütze oder mittels Fußleisten erfolgen.
Zur Ölversorgung ist die Tabelle 2 zu beachten.

Montaj Şekli: d1 mili yukarı doğru
Mounting position: Shaft d1 upward
Einbaulage: Welle d1 nach oben

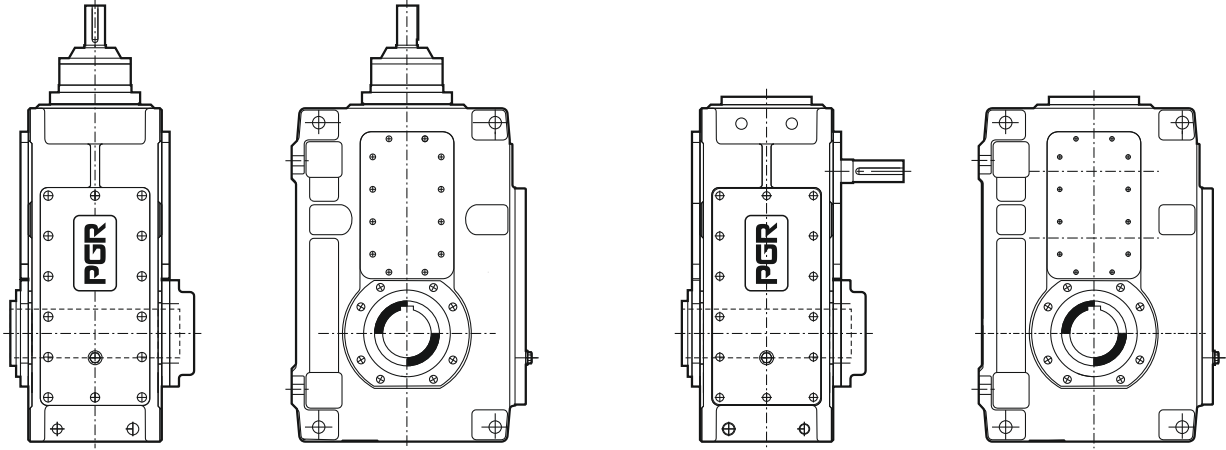

Montaj Şekli: d1 mili aşağı doğru
Mounting position: Shaft d1 downward
Einbaulage: Welle d1 nach unten

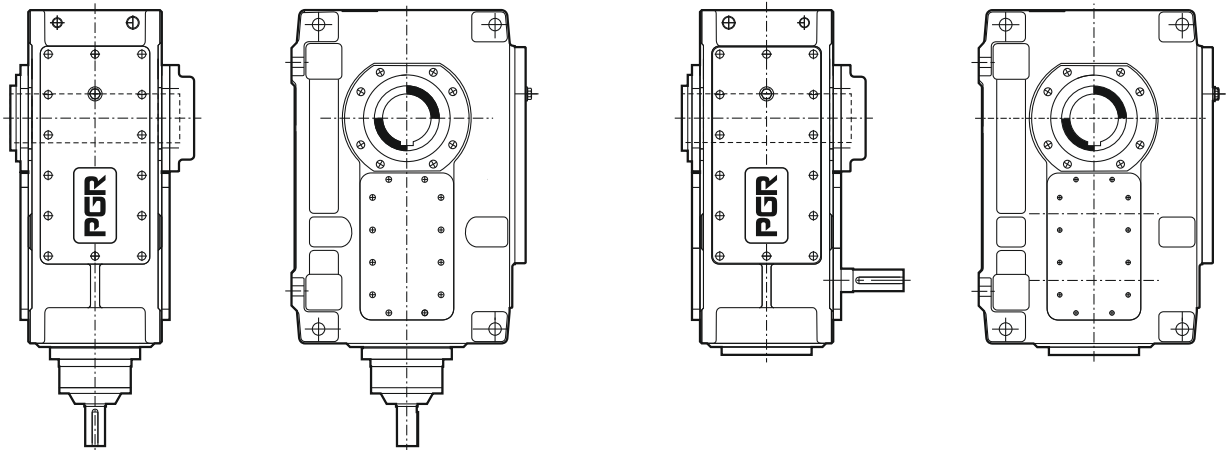

TR REDÜKTÖR TABAN AYAGININ ÖZEL MONTAJ DURUMLARI

EN SPECIAL MOUNTING POSITIONS HOUSING BASE RAILS

DE SONDEREINBAULAGEN GETRIEBEFÜßLEISTEN

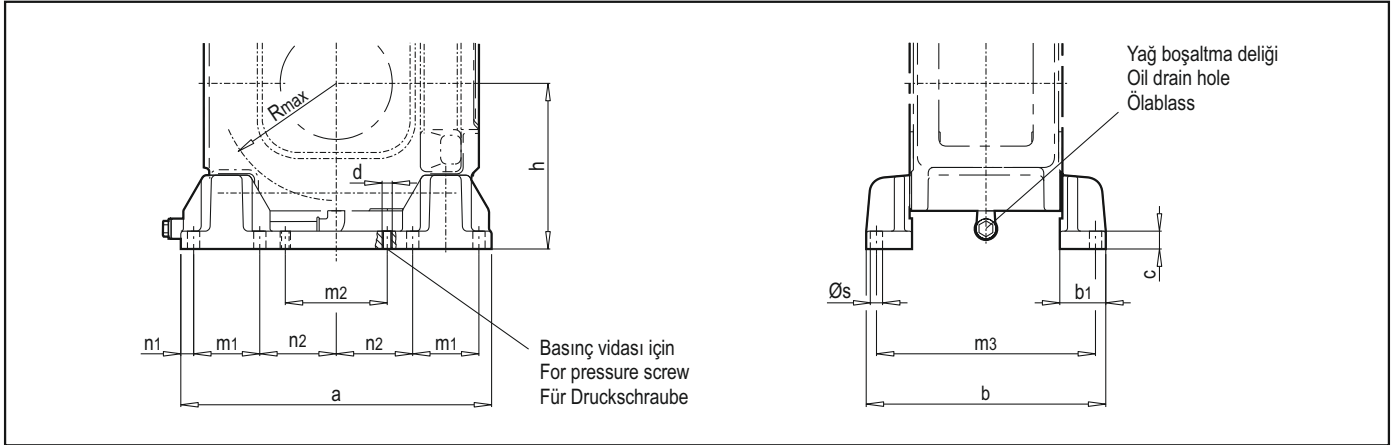

Tablo 1 / Table 1 / Tabelle 1

Gövde Size Größe	PH...2, PH...3, PH...4, PB...2, PB...3, PB...4											PH..2, PH..3, PH..4, PB..3, PB..4		PB...2	
	a	b1	c	4 x d	h	m1	m2	n1	n2	8xØs	Rmax	b	m3	b	m3
4...	450	75	28	M 16	255	110	130	20	95	19	160	355	315	-	-
5...	510	75	28	M 16	270	110	170	20	125	19	190	395	355	460	420
6...					315						220				
7...	610	90	35	M 20	325	130	200	25	150	24	230	470	420	550	500
8...					385						270				
9...	710	110	40	M 24	380	160	230	30	165	28	260	580	520	650	590
10...					430						300				
11...	860	120	50	M 30	435	190	270	35	205	35	340	660	590	760	690
12...					520						380				
13...	965	100	60	M 30	430	260	230	37.5	185	35	300	745	665	850	770
14...					500						360				
15...	1060	110	70	M 36	505	300	190	45	185	42	350	840	750	980	890
16...					550						400				
17...	1210	125	80	M 42	550	340	250	55	210	48	390	930	820	1125	1015
18...					610						440				

Tablo 2 / Table 2 / Tabelle 2

Gövde Size Größe	PH...2	PH...3	PH...4	PB...2	PB...3	PB...4
4.. - 12..	Daldırmalı yağlama Dip lubrication Tauchschmierung	Yağ tankı ile daldırmalı yağlama Dip lubrication with oil compensating tank Tauchschmierung mit Ölausgleichsbehälter	Yağ tankı ile Daldırmalı yağlama Dip lubrication with oil compensating tank Tauchschmierung mit Ölausgleichsbehälter	Flanşlı Pompa ile basınçlı yağlama Forced lubrication with flanged-on pump Druckschmierung mit Flanschpumpe	Flanşlı Pompa ile basınçlı yağlama Forced lubrication with flanged-on pump Druckschmierung mit Flanschpumpe	Flanşlı Pompa ile basınçlı yağlama Forced lubrication with flanged-on pump Druckschmierung mit Flanschpumpe
13.. - 18..	Flanşlı Pompa ile basınçlı yağlama Forced lubrication with flanged-on pump Druckschmierung mit Flanschpumpe	Flanşlı Pompa ile basınçlı yağlama Forced lubrication with flanged-on pump Druckschmierung mit Flanschpumpe	Motor pompa ile basınçlı yağlama Forced lubrication with motor pump Druckschmierung mit Motorpumpe	Flanşlı Pompa ile basınçlı yağlama Forced lubrication with flanged-on pump Druckschmierung mit Flanschpumpe	Flanşlı Pompa ile basınçlı yağlama Forced lubrication with flanged-on pump Druckschmierung mit Flanschpumpe	Motor pompa ile basınçlı yağlama Forced lubrication with motor pump Druckschmierung mit Motorpumpe

Yağlamada kullanılacak elemanlar için boşlukları göz önüne alınız. (örn, pompa boru) ölçüler talep edildiğinde.

Take into account space required for oil supplyelements (pump, pipes , etc.)! Dimensions on request

Freiraum für Elemente der Ölversorgung (Pumpe, Rohre usw.) beachten! Abmessungen auf Anfrage

TR

SU TESİSATI TASARIMI

EN

FOR WATER SCREWS

DE

WASSERSCHNECKENAUSFÜHRUNG

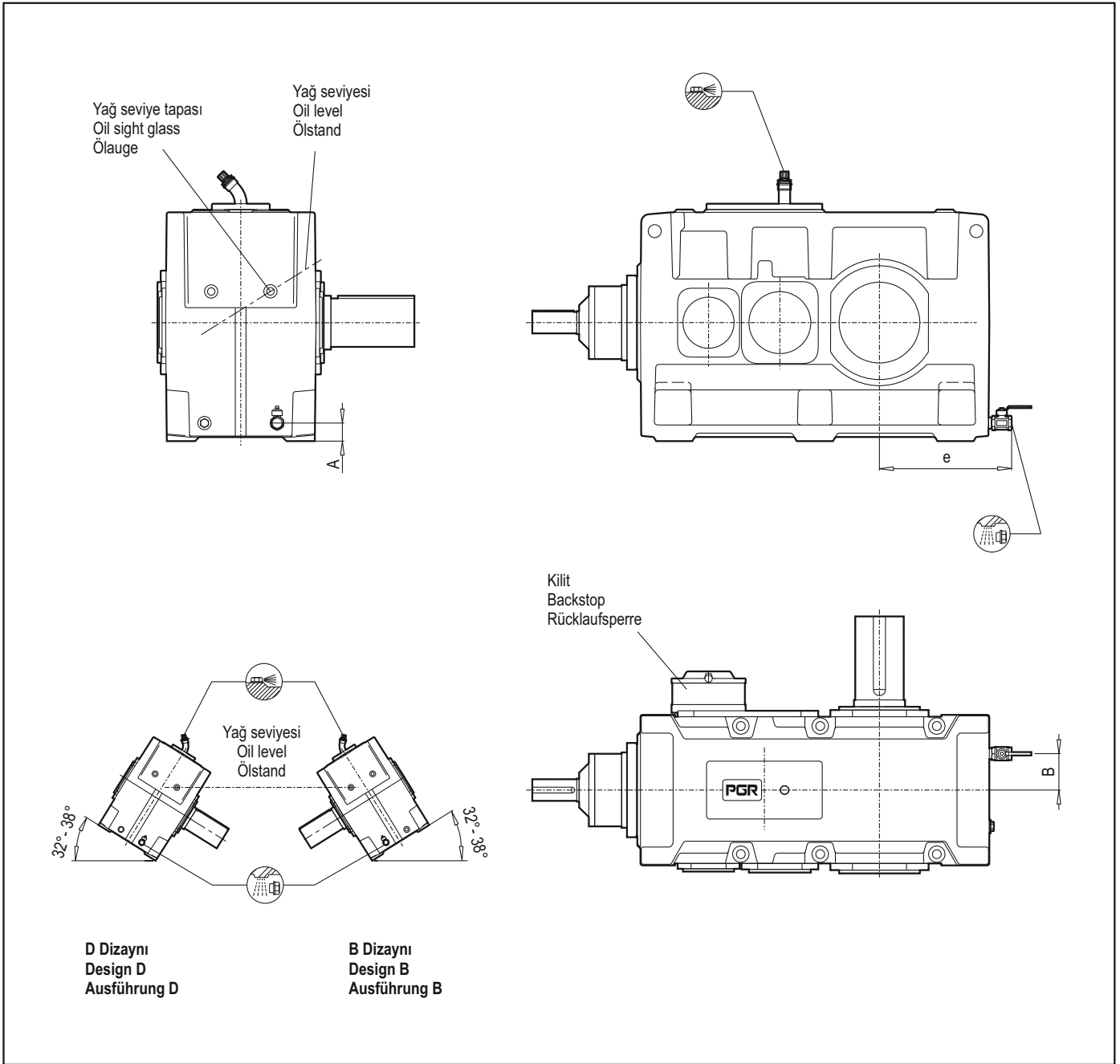

Tablo 2 / Table 2 / Tabelle 2

Tip Type Bauart	Gövde Size Größe	A mm	B mm	e mm	Yağ boşaltma valfi Oil drain valve Ölablasshahn
PB...3SH	133	68	136	505	G 1 1/4
	143			575	
	153	81	151	615	G 2
	163			660	
	173	86	181	655	G 2
	183			715	

TR MOTOR PLATFORMU - YATAY

EN MOTOR BRACKETS - HORIZONTAL

DE MOTORSTÜHLE - HORIZONTAL

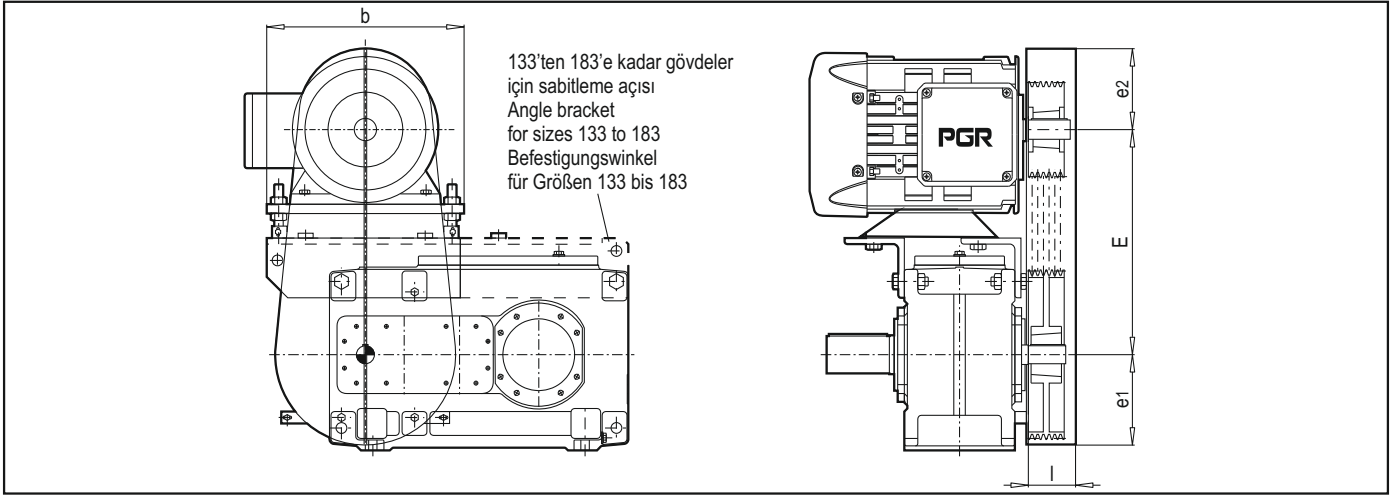

Tablo 1 / Table 1 / Tabelle 1

Tip-Gövde Type-Size Bauart-Größe	IEC-Motor	i Redüktör i Gear unit i Getriebe	i Kasnak Tahvili i Belt drive i Riementrieb	i Toplam i Total i Gesamt	Motor mili kasnağı Motor shaft pulley Riemenscheibe Motorwelle	Kayış Adeti No. of belts Riemen- anzahl	b mm	E mm	e ₁ mm	e ₂ mm	l mm
PH53-H	132 S	71 - 90	1.25	89 - 162	SPZ 140	2	395	493	185	182	125
	132 M	50 - 90	1.4	63 - 162	SPZ 140	3	395	493	185	182	125
	160 M	35.5 - 71	1.6	44 - 128	SPZ 180	3	395	530	185	145	125
	160 L	25 - 50	1.8	31 - 90	SPA 180	3	395	530	185	145	125
PH63-H	132 S	90 - 112	1.25	113 - 202	SPZ 140	2	395	493	185	182	125
	132 M	63 - 112	1.4	79 - 202	SPZ 140	3	395	493	185	182	125
	160 M	45 - 90	1.6	56 - 162	SPZ 180	3	395	530	185	145	125
	160 L	31.5 - 71	1.8	39 - 128	SPA 180	3	395	530	185	145	125
PH73-H	160 M	63 - 90	1.25	79 - 162	SPZ 180	3	465	586	255	229	125
	160 L	50 - 90		63 - 162	SPA 180	3	465	586	255	229	125
	180 M	40 - 71		50 - 128	SPA 250	3	465	626	255	189	125
	180 L	31.5 - 63		39 - 113	SPA 250	3	465	626	255	189	125
	200 L	25 - 45		31 - 54	SPB 280	3	575	680	205	205	155
	225 S	25 - 40		31 - 50	SPB 280	3	575	680	205	205	155
PH83-H	160 M	80 - 112	1.25	100 - 202	SPZ 180	3	465	586	255	229	125
	160 L	63 - 112		79 - 202	SPA 180	3	465	586	255	229	125
	180 M	50 - 90		63 - 162	SPA 250	3	465	626	255	189	125
	180 L	40 - 80		50 - 144	SPA 250	3	465	626	255	189	125
	200 L	31.5 - 56		39 - 70	SPB 280	3	575	680	205	205	155
	225 S	31.5 - 50		39 - 63	SPB 280	3	575	680	205	205	155
PH93-H	160 L	80 - 90	1.25	100 - 162	SPA 180	3	465	615	255	240	140
	180 M	71 - 90		89 - 162	SPA 250	3	465	664	255	191	140
	180 L	56 - 90		70 - 162	SPA 250	3	465	664	255	191	140
	200 L	40 - 80		50 - 144	SPB 280	3	575	747	280	208	155
	225 S	31.5 - 63		39 - 113	SPB 280	3	575	750	280	205	155
	225 M	28 - 50		35 - 90	SPB 280	4	575	750	280	205	155
	250 M	25 - 45		31 - 81	SPB 315	4	665	804	310	231	155
	PH103-H	160 L		100 - 112	1.25	125 - 202	SPA 180	3	465	615	255
180 M		80 - 112	100 - 202	SPA 250		3	465	664	255	191	140
180 L		71 - 112	89 - 202	SPA 250		3	465	664	255	191	140
200 L		50 - 100	63 - 180	SPB 280		3	575	747	280	208	155
225 S		40 - 80	50 - 144	SPB 280		3	575	750	280	205	155
225 M		31.5 - 63	39 - 113	SPB 280		4	575	750	280	205	155
250 M		31.5 - 56	39 - 101	SPB 315		4	665	804	310	231	155

TR

MOTOR PLATFORMU - YATAY

EN

MOTOR BRACKETS - HORIZONTAL

DE

MOTORSTÜHLE - HORIZONTAL

Tip-Gövde Type-Size Bauart-Größe	IEC-Motor	i Redüktör i Gear unit i Getriebe	i Kasnak Tahvilii i Belt drive i Riementrieb	i Toplam i Total i Gesamt	Motor mili kasnağı Motor shaft pulley Riemenscheibe Motorwelle	Kayış Adeti No. of belts Riemen- anzahl	b mm	E mm	e ₁ mm	e ₂ mm	l mm
PH113-H	200 L	71 - 90	1.25 1.4 1.6 1.8	89 - 162	SPB 280	3	575	825	280	205	155
	225 S	56 - 90		70 - 162	SPB 280	3	575	825	280	205	155
	225 M	50 - 90		63 - 162	SPB 280	4	575	825	280	205	155
	250 M	40 - 71		50 - 128	SPB 315	4	725	897	310	273	155
	280 S	31.5 - 56		39 - 101	SPB 315	5	725	938	310	232	155
	280 M	25 - 45		31 - 81	SPB 315	6	725	938	310	232	155
	315 S	25 - 35.5		31 - 64	SPC 355	5	815	1001	345	254	185
PH123-H	200 L	90 - 112	1.25 1.4 1.6 1.8	113 - 202	SPB 280	3	575	825	280	205	155
	225 S	71 - 112		89 - 202	SPB 280	3	575	825	280	205	155
	225 M	63 - 112		79 - 202	SPB 280	4	575	825	280	205	155
	250 M	50 - 90		63 - 162	SPB 315	4	725	897	310	273	155
	280 S	35.5 - 63		44 - 113	SPB 315	5	725	938	310	232	155
	280 M	31.5 - 56		39 - 101	SPB 315	6	725	938	310	232	155
	315 S	31.5 - 45		39 - 81	SPC 355	5	815	1001	345	254	185
PH133-H	225 M	80 - 90	1.25 1.4 1.6 1.8	100 - 162	SPB 280	4	575	881	280	204	180
	250 M	63 - 90		79 - 162	SPB 315	4	725	938	310	232	160
	280 S	45 - 80		56 - 144	SPB 315	5	725	938	310	232	160
	280 M	40 - 71		50 - 128	SPB 315	6	725	938	310	232	160
	315 S	31.5 - 56		39 - 101	SPC 355	5	815	1042	385	273	230
	315 M	22.4 - 50		28 - 90	SPC 355	6	815	1042	385	273	230
	PH143-H	225 M		90 - 112	1.25 1.4 1.6 1.8	113 - 202	SPB 280	4	575	881	280
250 M		80 - 112	100 - 202	SPB 315		4	725	938	310	232	160
280 S		56 - 100	70 - 180	SPB 315		5	725	938	310	232	160
280 M		45 - 90	56 - 162	SPB 315		6	725	938	310	232	160
315 S		40 - 71	50 - 128	SPC 355		5	815	1042	385	273	230
315 M		28 - 63	35 - 113	SPC 355		6	815	1042	385	273	230
PH153-H		280 S	80 - 90	1.25 1.4 1.6 1.8		100 - 162	SPB 315	5	725	980	310
	280 M	63 - 90	79 - 162		SPB 315	6	725	980	310	230	220
	315 S	50 - 90	63 - 162		SPC 355	5	815	1060	385	275	230
	315 M	45 - 80	56 - 144		SPC 355	6	815	1060	385	270	230
PH163-H	280 S	90 - 100	1.25 1.4 1.6 1.8	113 - 180	SPB 315	5	725	980	310	230	220
	280 M	71 - 100		89 - 180	SPB 315	6	725	980	310	230	220
	315 S	56 - 100		70 - 180	SPC 355	5	815	1060	385	275	230
	315 M	50 - 90		63 - 162	SPC 355	6	815	1060	385	275	230
PH173-H	280 M	80 - 90	1.25 1.4 1.6 1.8	100 - 162	SPB 315	6	725	1072	310	228	220
	315 S	71 - 90		89 - 162	SPC 355	5	815	1117	385	273	230
	315 M	63 - 90		79 - 162	SPC 355	6	815	1117	385	273	230
PH183-H	280 M	100	1.25 1.4 1.6 1.8	125 - 180	SPB 315	6	725	1072	310	228	220
	315 S	90 - 100		113 - 180	SPC 355	5	815	1117	385	273	230
	315 M	71 - 100		89 - 180	SPC 355	6	815	1117	385	273	230

TR MOTOR PLATFORMU - YATAY

EN MOTOR BRACKETS - HORIZONTAL

DE MOTORSTÜHLE HORIZONTAL

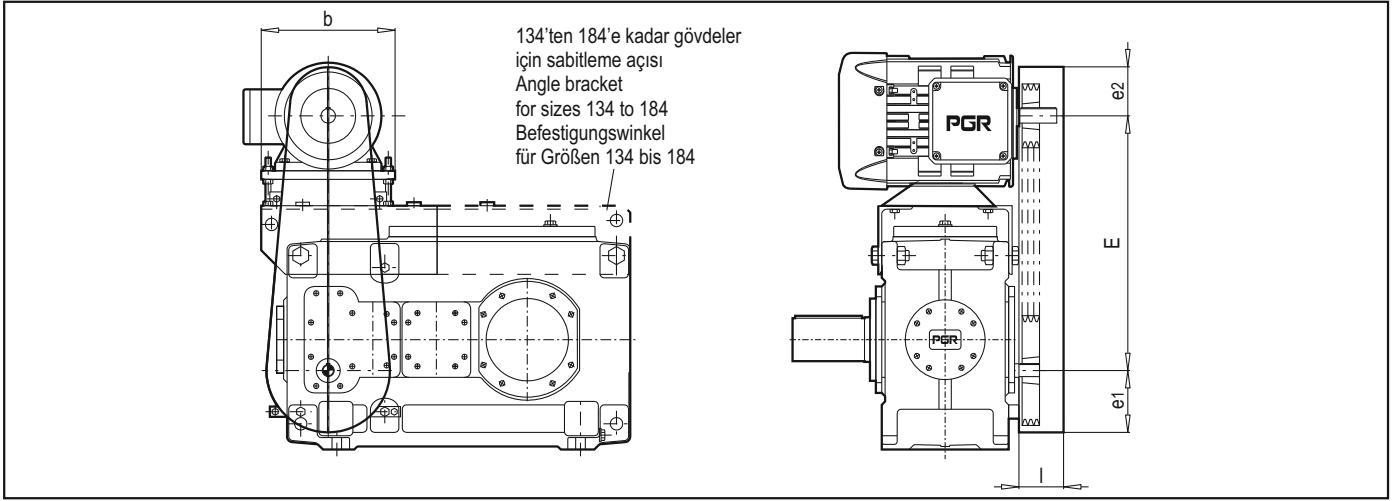

Tablo 2 / Table 2 / Tabelle 2

Tip Type Bauart Gövde Size Größe	IEC-Motor	i Redüktör i Gear unit i Getriebe	i Kasnak Tahvili i Belt drive i Riementrieb	i Toplam i Total i Gesamt	Motor mili kasnağı Motor shaft pulley Riemenscheibe Motorwelle	Kayış Adeti No. of belts Riemen- anzahl	b	E	e1	e2	l
							mm	mm	mm	mm	mm
PH74-H	100 L	250 - 355	1.25 1.4 1.6 1.8	313 - 639	SPZ 100	2	315	597	130	128	75
	112 M	180 - 355		225 - 639	SPZ 112	2	315	613	130	112	75
	132 S	140 - 250		175 - 450	SPZ 140	2	355	632	155	128	95
	132 M	100 - 180		125 - 324	SPZ 140	3	355	632	155	128	95
PH84-H	100 L	315 - 450	1.25 1.4 1.6 1.8	394 - 810	SPZ 100	2	315	597	130	128	75
	112 M	224 - 450		280 - 810	SPZ 112	2	315	613	130	112	75
	132 S	180 - 355		225 - 639	SPZ 140	2	355	632	155	128	95
	132 M	125 - 250		156 - 450	SPZ 140	3	355	632	155	128	95
PH94-H	112 M	315 - 355	1.25 1.4 1.6 1.8	394 - 639	SPZ 112	2	395	672	130	113	75
	132 S	224 - 355		280 - 639	SPZ 140	2	395	701	185	159	125
	132 M	160 - 315		200 - 567	SPZ 140	3	395	701	185	159	125
	160 M	112 - 224		140 - 403	SPZ 180	3	395	742	185	148	125
	160 L	100 - 160		125 - 288	SPA 180	3	395	742	185	148	125
PH104-H	112 M	400 - 450	1.25 1.4 1.6 1.8	500 - 810	SPZ 112	2	395	672	130	113	75
	132 S	280 - 450		350 - 810	SPZ 140	2	395	701	185	159	125
	132 M	200 - 400		250 - 720	SPZ 140	3	395	701	185	159	125
	160 M	140 - 280		175 - 504	SPZ 180	3	395	742	185	148	125
	160 L	125 - 180		156 - 324	SPA 180	3	395	742	185	148	125
PH114-H	132 M	280 - 355	1.25 1.4 1.6 1.8	350 - 639	SPZ 140	3	465	785	155	125	115
	160 M	200 - 355		250 - 639	SPZ 180	3	465	842	255	203	125
	160 L	140 - 280		175 - 504	SPA 180	3	465	842	255	203	125
	180 M	125 - 224		156 - 403	SPA 250	3	465	852	255	193	125
	180 L	100 - 180		125 - 324	SPA 250	3	465	852	255	193	125
	200 L	100 - 140		125 - 252	SPB 280	3	525	923	255	207	125
PH124-H	132 M	355 - 450	1.25 1.4 1.6 1.8	444 - 810	SPZ 140	3	465	785	155	125	115
	160 M	250 - 450		313 - 810	SPZ 180	3	465	842	255	203	125
	160 L	180 - 355		225 - 639	SPA 180	3	465	842	255	203	125
	180 M	140 - 280		175 - 504	SPA 250	3	465	852	255	193	125
	180 L	125 - 224		156 - 403	SPA 250	3	465	852	255	193	125
	200 L	125 - 180		156 - 324	SPB 280	3	520	923	255	207	125

TR MOTOR PLATFORMU - YATAY

EN MOTOR BRACKETS - HORIZONTAL

DE MOTORSTÜHLE HORIZONTAL

Tip Type Bauart Gövde Size Größe	IEC-Motor	i Redüktör i Gear unit i Getriebe	i Kasnak Tahvili i Belt drive i Riementrieb	i Toplam i Total i Gesamt	Motor mili kasnağı Motor shaft pulley Riemenscheibe Motorwelle	Kayış Adeti No .of belts Riemen- anzahl	b mm	E mm	e1 mm	e2 mm	l mm
PH134-H	160 M	315 - 355	1.25 1.4 1.6 1.8	394 - 639	SPZ 180	3	465	934	255	171	130
	160 L	224 - 355		280 - 639	SPA 180	3	465	934	255	171	130
	180 M	180 - 355		225 - 639	SPA 250	3	465	914	255	191	130
	180 L	160 - 280		200 - 504	SPA 250	3	465	914	255	191	130
	200 L	112 - 224		140 - 403	SPB 280	3	575	1001	280	219	160
	225 S	100 - 180		125 - 324	SPB 280	3	575	1001	280	219	160
	225 M	100 - 140		125 - 252	SPB 280	4	575	1001	280	219	160
PH144-H	160 M	400 - 450	1.25 1.4 1.6 1.8	500 - 810	SPZ 180	3	465	934	255	171	130
	160 L	280 - 450		350 - 810	SPA 180	3	465	934	255	171	130
	180 M	224 - 450		280 - 810	SPA 250	3	465	914	255	191	130
	180 L	200 - 355		250 - 639	SPA 250	3	465	914	255	191	130
	200 L	140 - 280		175 - 504	SPB 280	3	575	1001	280	219	160
	225 S	125 - 224		156 - 403	SPB 280	3	575	1001	280	219	160
	225 M	125 - 180		156 - 324	SPB 280	4	575	1001	280	219	160
PH154-H	160 L	355	1.25 1.4 1.6 1.8	444 - 639	SPA 180	3	465	928	255	237	155
	180 M	315 - 355		394 - 639	SPA 250	3	465	964	255	201	155
	180 L	250 - 355		313 - 639	SPA 250	3	465	964	255	201	155
	200 L	180 - 355		225 - 639	SPB 280	3	575	1057	280	213	160
	225 S	160 - 280		200 - 504	SPB 280	3	575	1057	280	213	160
	225 M	125 - 250		156 - 450	SPB 280	4	575	1057	280	213	160
	250 M	100 - 200		125 - 360	SPB 315	4	665	1131	310	234	160
PH164-H	180 M	280 - 400	1.25 1.4 1.6 1.8	350 - 720	SPA 250	3	465	964	255	201	155
	180 L	224 - 400		280 - 720	SPA 250	3	465	964	255	201	155
	200 L	180 - 355		225 - 639	SPB 280	3	575	1057	280	213	160
	225 S	140 - 280		175 - 504	SPB 280	3	575	1057	280	213	160
	225 M	112 - 224		140 - 403	SPB 280	4	575	1057	280	213	160
	250 M	112 - 224		140 - 403	SPB 315	4	665	1131	310	234	160
				140 - 403	SPB 315	4	665	1131	310	234	160
PH174-H	180 L	355	1.25 1.4 1.6 1.8	444 - 639	SPA 250	3	525	1047	280	195	130
	200 L	250 - 355		313 - 639	SPB 280	3	525	1098	280	212	130
	225 S	200 - 355		250 - 639	SPB 280	3	665	1157	310	258	160
	225 M	180 - 315		225 - 567	SPB 280	4	665	1157	310	258	160
	250 M	140 - 280		175 - 504	SPB 315	4	665	1181	310	234	160
	280 S	100 - 200		125 - 360	SPB 315	5	725	1231	310	234	160
	280 M	100 - 160		125 - 288	SPB 315	6	725	1231	310	234	160
PH184-H	200 L	315 - 400	1.25 1.4 1.6 1.8	394 - 720	SPB 280	3	525	1098	280	212	130
	225 S	250 - 400		313 - 720	SPB 280	3	665	1157	310	258	160
	225 M	224 - 400		280 - 720	SPB 280	4	665	1157	310	258	160
	250 M	180 - 355		225 - 639	SPB 315	4	665	1181	310	234	160
	280 S	125 - 250		156 - 450	SPB 315	5	725	1231	310	234	160
	280 M	112 - 200		140 - 360	SPB 315	6	725	1231	310	234	160

TR MOTOR PLATFORMU - YATAY

EN MOTOR BRACKETS - HORIZONTAL

DE MOTORSTÜHLE HORIZONTAL

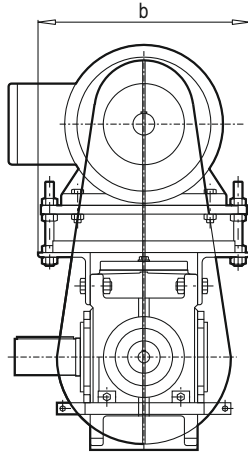

133'ten 183'e kadar gövdeler için sabitleme açısı
Angle bracket for sizes 133 to 183
Befestigungswinkel für Größen 133 bis 183

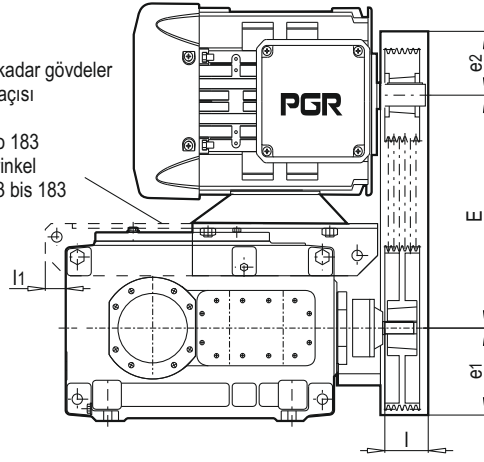

Tablo 3 / Table 3 / Tabelle 3

Tip-Gövde Type-Size Bauart-Größe	IEC-Motor	i Redüktör i Gear unit i Getriebe	i Kasnak Tahvili i Belt drive i Riementrieb	i Toplam i Total i Gesamt	Motor mil kasnağı Motor shaft pulley Riemenscheibe Motorwelle	Kayış Adeti No. of belts Riemen- anzahl	b mm	E mm	e1 mm	e2 mm	l mm
PB43-H	112 M	56 - 71	1.25	70 - 127.8	SPZ 112	2	380	421	125	109	90
	132 S	45 - 71		56.3 - 127.8	SPZ 140	2	460	434	185	187	125
	132 M	31.5 - 45		39.4 - 81	SPZ 140	3	460	434	185	187	125
	160 M	20 - 45		25 - 81	SPZ 180	3	460	476	185	145	125
	160 L	31.5 - 35.5		39.4 - 63.9	SPA 180	3	460	476	185	145	125
PB53-H	132 M	45 - 71	1.25	56.3 - 127.8	SPZ 140	3	420	476	185	172	125
	160 M	35.5 - 71		44.4 - 127.8	SPZ 180	3	420	502	185	146	125
	160 L	28 - 50		35 - 90	SPA 180	3	420	502	185	146	125
	180 M	22.4 - 40		28 - 64	SPA 250	3	500	534	225	176	125
	180 L	31.5 - 35.5		39.4 - 56.8	SPA 250	3	500	534	225	176	125
PB63-H	132 M	30 - 90	1.25	37.5 - 162	SPZ 140	3	420	476	185	172	125
	160 M	45 - 90		56.3 - 162	SPZ 180	3	420	502	185	146	125
	160 L	31.5 - 63		39.4 - 113.4	SPA 180	3	420	502	185	146	125
	180 M	28 - 50		35 - 80	SPA 250	3	500	534	225	176	125
	180 L	25 - 45		31.3 - 72	SPA 250	3	500	534	225	176	125
PB73-H	160 M	63 - 71	1.25	78.8 - 127.8	SPZ 180	3	455	553	185	142	125
	160 L	50 - 71		62.5 - 127.8	SPA 180	3	455	553	185	142	125
	180 M	40 - 71		50 - 127.8	SPA 250	3	665	588	278	325	155
	180 L	31.5 - 63		39.4 - 113.4	SPA 250	3	665	588	278	325	155
	200 L	25 - 45		31.3 - 81	SPB 280	3	665	643	278	270	155
	225 S	20 - 40		25 - 72	SPB 280	3	665	713	278	200	155
	225 M	20 - 31.5		25 - 56.7	SPB 280	4	665	713	278	200	155
PB83-H	160 M	80 - 90	1.25	100 - 162	SPZ 180	3	455	553	185	142	125
	160 L	63 - 90		78.8 - 162	SPA 180	3	455	553	185	142	125
	180 M	50 - 90		62.5 - 162	SPA 250	3	665	588	278	325	155
	180 L	40 - 80		50 - 144	SPA 250	3	665	588	278	325	155
	200 L	31.5 - 56		39.4 - 100.8	SPB 280	3	665	643	278	270	155
	225 S	25 - 45		31.3 - 81	SPB 280	3	665	713	278	200	155
	225 M	25 - 40		31.3 - 72	SPB 280	4	665	713	278	200	155
PB93-H	180 M	63 - 71	1.25	78.8 - 127.8	SPA 250	3	555	635	275	278	155
	180 L	56 - 71		70 - 127.8	SPA 250	3	555	635	275	278	155
	200 L	40 - 71		50 - 127.8	SPB 280	3	555	713	275	200	155
	225 S	40 - 53		50 - 113.4	SPB 280	3	555	713	275	200	155
	225 M	28 - 50		35 - 90	SPB 280	4	555	713	275	200	155
	250 M	22.4 - 45		28 - 81	SPB 315	4	735	762	305	274	155
	280 S	20 - 31.5		25 - 56.7	SPB 315	5	735	803	305	233	155
	280 M	20 - 25		25 - 45	SPB 315	6	735	803	305	233	155
PB103-H	180 M	80 - 90	1.25	100 - 162	SPA 250	3	555	635	275	282	155
	180 L	71 - 90		88.8 - 162	SPA 250	3	555	635	275	282	155
	200 L	50 - 90		62.5 - 162	SPB 280	3	555	713	275	200	155
	225 S	40 - 80		50 - 144	SPB 280	3	555	713	275	200	155
	225 M	31.5 - 63		39.4 - 113.4	SPB 280	4	555	713	275	200	155
	250 M	28 - 56		35 - 100.8	SPB 315	4	735	762	305	274	155
	280 S	25 - 40		31.3 - 72	SPB 315	5	735	803	305	233	155
	280 M	25 - 31.5		31.3 - 56.7	SPB 315	6	735	803	305	233	155

TR

MOTOR PLATFORMU - YATAY

EN

MOTOR BRACKETS - HORIZONTAL

DE

MOTORSTÜHLE HORIZONTAL

Tip Type Bauart Gövde Size Größe	IEC-Motor	i Redüktör i Gear unit i Getriebe	i Kasnak Tahvili i Belt drive i Riemetrieb	i Toplam i Total i Gesamt	Motor mili kasnağı Motor shaft pulley Riemenscheibe Motorwelle	Kayış sayısı No. of belts Riemen- anzahl	b mm	E mm	e1 mm	e2 mm	l mm	l1 mm
PB113-H	225 S	56 - 71	1.25 1.4 1.6 1.8	70 - 127.8	SPB 280	3	635	789	280	205	158	-
	225 M	45 - 71		56.3 - 127.8	SPB 280	4	635	789	280	205	158	
	250 M	40 - 71		50 - 127.8	SPB 315	4	795	854	310	273	163	
	280 S	28 - 56		35 - 100.8	SPB 315	5	795	897	310	230	163	
	280 M	22.4 - 45		28 - 81	SPB 315	6	795	897	310	230	163	
	315 S	20 - 35.5		25 - 63.9	SPC 355	5	835	992	345	255	189	
	315 M	20 - 31.5		25 - 56.7	SPC 355	6	835	992	345	255	189	
PB123-H	225 S	71 - 90	1.25 1.4 1.6 1.8	88.8 - 162	SPB 280	3	635	789	280	205	158	-
	225 M	56 - 90		70 - 162	SPB 280	4	635	789	280	205	158	
	250 M	50 - 90		62.5 - 162	SPB 315	4	795	854	310	273	163	
	280 S	35.5 - 63		44.4 - 113.4	SPB 315	5	795	897	310	230	163	
	280 M	31.5 - 56		39.4 - 100.8	SPB 315	6	795	897	310	230	163	
	315 S	25 - 45		31.3 - 81	SPC 355	5	835	992	345	255	189	
	315 M	25 - 40		31.3 - 72	SPC 355	6	835	992	345	255	189	
PB133-H	250 M	63 - 71	1.25 1.4 1.6 1.8	78.8 - 127.8	SPB 315	4	750	938	325	235	188	100
	280 S	45 - 71		56.3 - 127.8	SPB 315	5	750	938	325	235	188	
	280 M	35.5 - 71		44.4 - 127.8	SPB 315	6	750	938	325	235	188	
	315 S	31.5 - 56		39.4 - 100.8	SPC 355	5	950	1017	395	288	232	
	315 M	25 - 50		31.3 - 90	SPC 355	6	950	1017	395	288	232	
PB143-H	250 M	80 - 90	1.25 1.4 1.6 1.8	100 - 162	SPB 315	4	750	938	325	235	188	100
	280 S	56 - 90		70 - 162	SPB 315	5	750	938	325	235	188	
	280 M	45 - 90		56.3 - 162	SPB 315	6	750	938	325	235	188	
	315 S	40 - 71		50 - 127.8	SPC 355	5	950	1017	395	288	232	
	315 M	31.5 - 63		39.4 - 113.4	SPC 355	6	950	1017	395	288	232	
PB153-H	280 M	63 - 71	1.25 1.4 1.6 1.8	78.8 - 127.8	SPB 315	6	832	1031	310	230	185	120
	315 S	50 - 71		62.5 - 127.8	SPC 355	5	832	1042	385	270	231	
	315 M	45 - 71		56.3 - 127.8	SPC 355	6	832	1042	385	270	231	
PB163-H	280 M	71 - 90	1.25 1.4 1.6 1.8	88.8 - 162	SPB 315	6	832	1031	310	230	188	120
	315 S	56 - 80		70 - 144	SPC 355	5	832	1042	385	270	231	
	315 M	50 - 80		62.5 - 144	SPC 355	6	832	1042	385	270	231	
PB173-H	315 M	63 - 71		78.8 - 127.8	SPC 355	6	905	1118	385	277	232	120
PB183-H	315 M	71 - 80		88.8 - 144	SPC 355	6	905	1118	385	277	232	120

TR MOTOR PLATFORMU - YATAY

EN MOTOR BRACKETS - HORIZONTAL

DE MOTORSTÜHLE HORIZONTAL

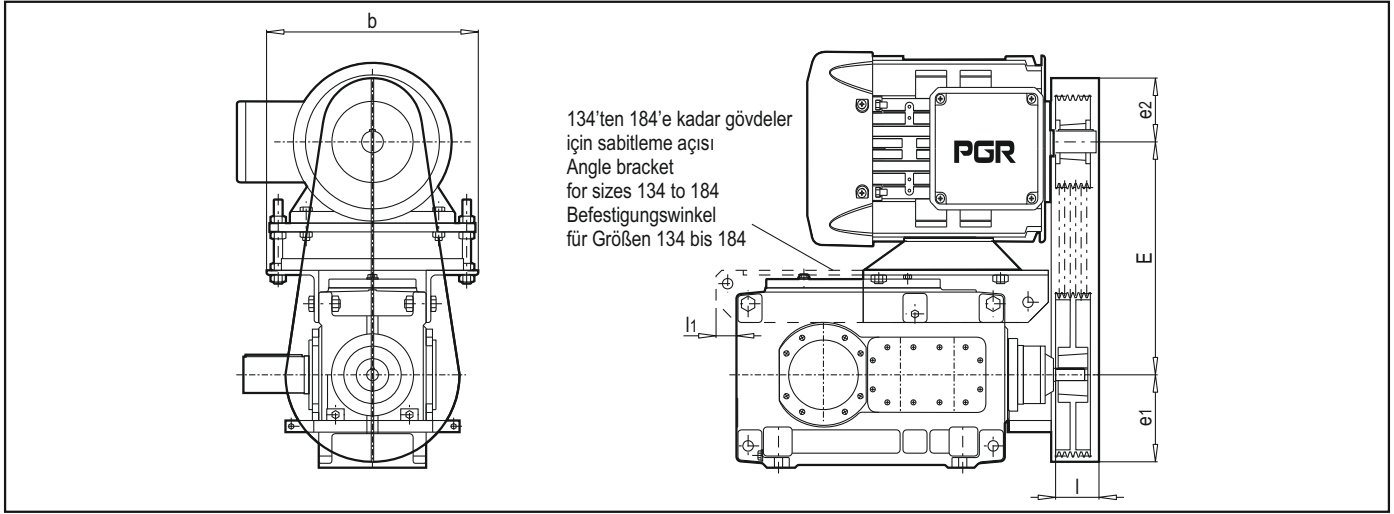

Tablo 4 / Table 4 / Tabelle 4

Tip - Gövde Type - Size Bauart - Größe	IEC-Motor	i Redüktör i Gear unit i Getriebe	i Kasnak Tahvili i Belt drive i Riementrieb	i Toplam i Total i Gesamt	Motor mili kasnağı Motor shaft pulley Riemenscheibe Motorwelle	Kayış Adeti No. of belts Riemen- anzahl	b mm	E mm	e1 mm	e2 mm	l mm
PB54-H	90 L	280 - 315	1.25	350 - 567	SPZ 80	2	390	430	130	135	80
	100 L	125 - 315		156 - 567	SPZ 100	2	390	442	130	123	80
	112 M	100 - 180		125 - 324	SPZ 112	2	390	458	130	107	80
	132 S	80 - 140		100 - 252	SPZ 140	2	390	482	155	128	97
	132 M	80 - 112		100 - 202	SPZ 140	3	390	482	155	128	97
PB64-H	90 L	355 - 400	1.25	444 - 720	SPZ 80	2	390	430	130	135	80
	100 L	160 - 400		200 - 720	SPZ 100	2	390	442	130	123	80
	112 M	125 - 250		156 - 450	SPZ 112	2	390	458	130	107	80
	132 S	100 - 180		125 - 324	SPZ 140	2	390	482	155	123	97
	132 M	100 - 140		125 - 252	SPZ 140	3	390	482	155	123	97
PB74-H	100 L	250 - 315	1.25	350 - 567	SPZ 100	2	327	497	130	123	83
	112 M	180 - 315		225 - 567	SPZ 112	2	455	513	130	107	83
	132 S	125 - 250		156 - 450	SPZ 140	2	455	530	185	160	125
	132 M	90 - 180		113 - 324	SPZ 140	3	455	530	185	160	125
	160 M	80 - 125		100 - 225	SPZ 180	3	455	552	185	138	125
	160 L	80 - 90		100 - 162	SPA 180	3	455	552	185	138	125
PB84-H	100 L	355 - 400	1.25	444 - 720	SPZ 100	2	327	497	130	123	83
	112 M	224 - 400		280 - 720	SPZ 112	2	455	513	130	107	83
	132 S	160 - 315		200 - 567	SPZ 140	2	455	530	185	160	125
	132 M	125 - 224		156 - 403	SPZ 140	2	455	530	185	160	125
	160 M	100 - 160		125 - 288	SPZ 180	3	455	552	185	138	125
	160 L	100 - 125		125 - 225	SPA 180	3	455	552	185	138	125
PB94-H	132 S	224 - 315	1.25	280 - 567	SPZ 140	2	555	572	185	183	125
	132 M	160 - 315		200 - 567	SPZ 140	3	555	572	185	183	125
	160 M	112 - 224		140 - 403	SPZ 180	3	555	615	185	140	125
	160 L	80 - 160		100 - 288	SPA 180	3	555	615	185	140	125
	180 M	80 - 140		100 - 252	SPA 250	3	555	626	255	189	125
	180 L	80 - 112		100 - 202	SPA 250	3	555	626	255	189	125
PB104-H	132 S	280 - 400	1.25	350 - 720	SPZ 140	2	555	572	185	188	125
	132 M	200 - 400		250 - 720	SPZ 140	3	555	572	185	188	125
	160 M	140 - 280		175 - 504	SPZ 180	3	555	615	185	145	125
	160 L	100 - 200		125 - 360	SPA 180	3	555	615	185	145	125
	180 M	100 - 160		125 - 288	SPA 250	3	555	626	255	189	125
	180 L	100 - 140		125 - 252	SPA 250	3	555	626	255	189	125
PB114-H	132 M	280 - 315	1.25	350 - 567	SPZ 140	3	459	644	185	171	125
	160 M	200 - 315		250 - 567	SPZ 180	3	459	668	185	147	125
	160 L	140 - 280		175 - 504	SPA 180	3	459	668	185	147	125
	180 M	112 - 224		140 - 403	SPA 250	3	635	709	280	321	155
	180 L	90 - 200		113 - 360	SPA 250	3	635	709	280	321	155
	200 L	80 - 140		100 - 252	SPB 280	3	635	750	280	280	155
	225 S	80 - 112		100 - 202	SPB 280	3	635	825	280	205	155
	225 M	80 - 90		100 - 162	SPB 280	4	635	825	280	205	155

TR

MOTOR PLATFORMU - YATAY

EN

MOTOR BRACKETS - HORIZONTAL

DE

MOTORSTÜHLE HORIZONTAL

Tip Type Bauart Gövde Size Größe	IEC-Motor	i Redüktör i Gear unit i Getriebe	i Kasnak Tahvilii i Belt drive i Riementrieb	i Toplam i Total i Gesamt	Motor mili kasnağı Motor shaft pulley Riemenscheibe Motorwelle	Kayış Adeti No .of belts Riemen- anzahl	b mm	E mm	e1 mm	e2 mm	l mm	l1 mm
PB124-H	132 M	355 - 400	1.25 1.4 1.6 1.8	444 - 720	SPZ 140	3	459	644	185	171	125	-
	160 M	250 - 400		313 - 720	SPZ 180	3	459	668	185	147	125	
	160 L	180 - 355		225 - 639	SPA 180	3	459	668	185	147	125	
	180 M	140 - 280		175 - 504	SPA 250	3	635	709	280	321	155	
	180 L	125 - 224		156 - 403	SPA 250	3	635	709	280	321	155	
	200 L	100 - 160		125 - 288	SPB 280	3	635	750	280	280	155	
	225 S	100 - 140		125 - 252	SPB 280	3	635	825	280	205	155	
	225 M	100 - 112		125 - 202	SPB 280	4	635	825	280	205	155	
PB134-H	160 L	224 - 315	1.25 1.4 1.6 1.8	280 - 567	SPA 180	3	580	764	255	191	130	100
	180 M	180 - 315		225 - 567	SPA 250	3	580	764	255	191	130	
	180 L	160 - 280		200 - 504	SPA 250	3	580	764	255	191	130	
	200 L	112 - 200		140 - 360	SPB 280	3	580	825	280	260	160	
	225 S	90 - 160		113 - 288	SPB 280	3	756	881	280	204	160	
	225 M	80 - 140		100 - 252	SPB 280	4	756	881	280	204	160	
	250 M	80 - 112		100 - 202	SPB 315	4	758	938	310	277	160	
	280 S	80 - 90		100 - 162	SPB 315	5	758	980	310	235	160	
PB144-H	160 L	280 - 400	1.25 1.4 1.6 1.8	350 - 720	SPA 180	3	580	764	255	191	130	100
	180 M	224 - 400		280 - 720	SPA 250	3	580	764	255	191	130	
	180 L	180 - 355		225 - 639	SPA 250	3	580	764	255	191	130	
	200 L	140 - 250		175 - 450	SPB 280	3	580	825	280	260	160	
	225 S	112 - 200		140 - 360	SPB 280	3	756	881	280	204	160	
	225 M	100 - 180		125 - 324	SPB 280	4	756	881	280	204	160	
	250 M	100 - 140		125 - 252	SPB 315	4	758	938	310	277	160	
	280 S	100 - 112		125 - 202	SPB 315	5	758	980	310	235	160	
PB154-H	180 L	250 - 315	1.25 1.4 1.6 1.8	313 - 567	SPA 250	3	655	797	280	288	155	120
	200 L	180 - 315		225 - 567	SPB 280	3	655	881	280	204	155	
	225 S	140 - 315		175 - 567	SPB 280	3	655	923	310	292	160	
	225 M	125 - 250		156 - 450	SPB 280	4	655	923	310	292	160	
	250 M	100 - 200		125 - 360	SPB 315	4	825	938	310	277	160	
	280 S	80 - 140		100 - 252	SPB 315	5	825	980	310	235	160	
	280 M	80 - 125		100 - 225	SPB 315	6	825	980	310	235	160	
	315 S	80 - 100		100 - 180	SPC 355	5	825	1051	345	259	190	
PB164-H	180 L	280 - 355	1.25 1.4 1.6 1.8	350 - 639	SPA 250	3	655	797	280	288	155	120
	200 L	200 - 355		250 - 639	SPB 280	3	655	881	280	204	155	
	225 S	160 - 355		200 - 639	SPB 280	3	655	923	310	292	160	
	225 M	140 - 180		175 - 504	SPB 280	4	655	923	310	292	160	
	250 M	112 - 224		140 - 403	SPB 315	4	825	938	310	277	160	
	280 S	90 - 160		113 - 288	SPB 315	5	825	980	310	235	160	
	280 M	90 - 140		113 - 252	SPB 315	6	825	980	310	235	160	
	315 S	90 - 112		113 - 202	SPC 355	5	825	1051	345	259	190	
PB174-H	200 L	250 - 315	1.25 1.4 1.6 1.8	313 - 567	SPB 280	3	715	1001	280	219	160	120
	225 S	200 - 315		250 - 567	SPB 280	3	715	1001	280	219	160	
	225 M	160 - 315		200 - 567	SPB 280	4	715	1001	280	219	160	
	250 M	140 - 280		175 - 504	SPB 315	4	885	1031	310	289	160	
	280 S	100 - 200		125 - 360	SPB 315	5	885	1081	310	239	160	
	280 M	80 - 160		100 - 288	SPB 315	6	885	1081	310	239	160	
	315 S	80 - 140		100 - 252	SPC 355	5	885	1101	385	299	235	
	315 M	80 - 112		100 - 202	SPC 355	6	885	1101	385	299	235	
PB184-H	200 L	315 - 355	1.25 1.4 1.6 1.8	394 - 639	SPB 280	3	715	1001	280	219	160	120
	225 S	250 - 355		313 - 639	SPB 280	3	715	1001	280	219	160	
	225 M	224 - 355		280 - 639	SPB 280	4	715	1001	280	219	160	
	250 M	180 - 315		225 - 567	SPB 315	4	885	1031	310	289	160	
	280 S	125 - 250		156 - 450	SPB 315	5	885	1081	310	239	160	
	280 M	100 - 200		125 - 360	SPB 315	6	885	1081	310	239	160	
	315 S	90 - 160		113 - 288	SPC 355	5	885	1101	385	299	235	
	315 M	90 - 140		113 - 252	SPC 355	6	885	1101	345	259	235	

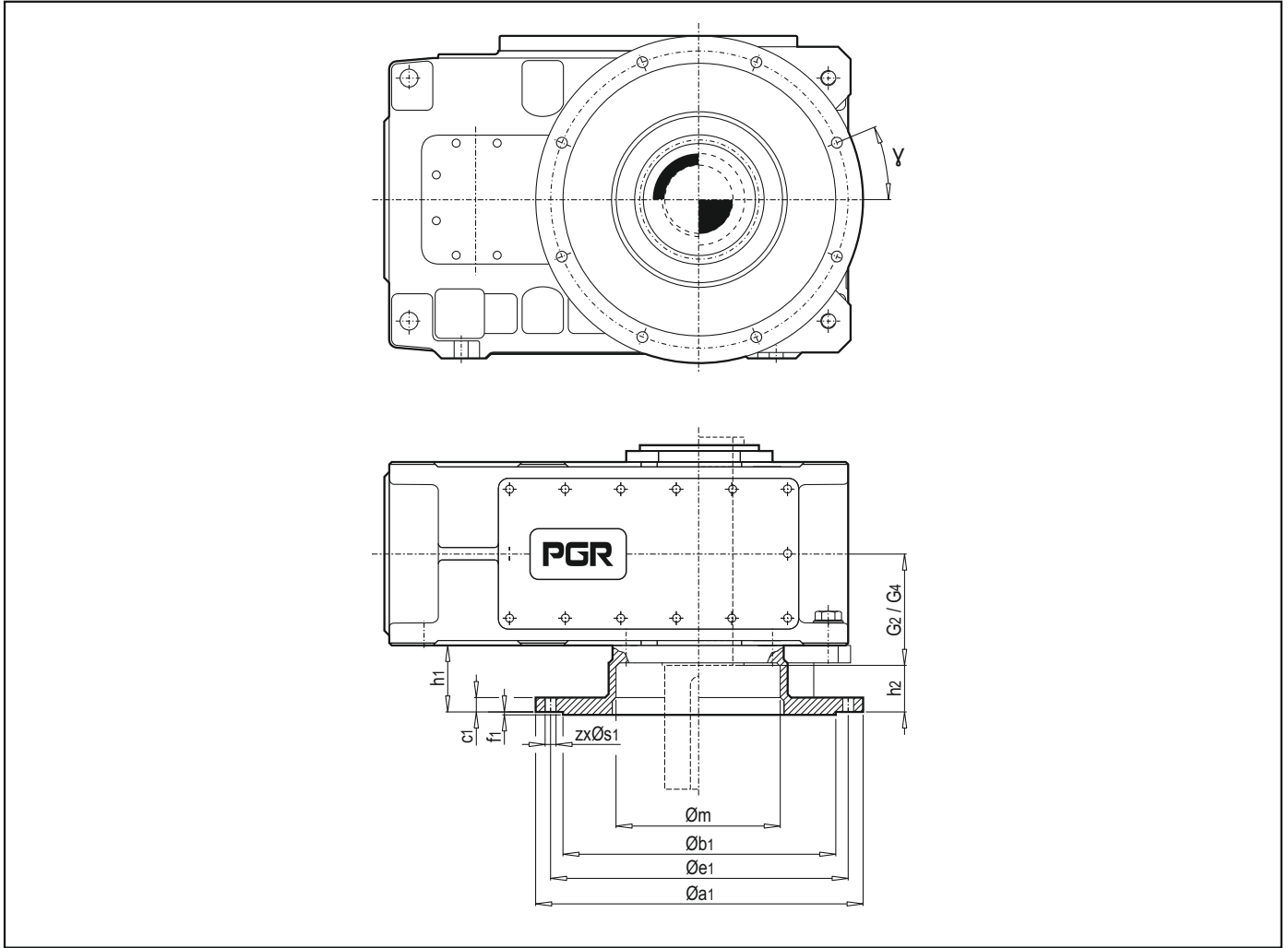

Not:

Mevcut / muhtemel imalat şekilleri için, Tablo 3'e bakın.
Kilit veya pompa kombinasyonu, talep üzerine temin edilir.
C ve D tasarımlı PH tipi redüktörlerde motor bağlantı adaptörü veya fanının kombinasyonu, talep üzerine temin edilir.

Notes:

For possible designs, see table 3.
Combination with backstop or pump on request.
Combination with motor bell housing or fan for PH-gear units of C and D design on request.

Hinweise:

Mögliche Ausführungsformen siehe Tabelle 3.
Kombinationen mit Rücklaufsperr oder Pumpe auf Anfrage.
Kombinationen mit Motorlaterne oder Lüfter bei PH-Getrieben der Ausführungsformen C und D auf Anfrage.

Tablo 1 / Table 1 / Tabelle 1									
Moment faktörü f / Torque factor f / Drehmomentfaktor f									
PH..2, PH..3, PH..4, PB..3, PB..4									
Faktör Factor Faktor	Gövde / Size / Größe								
	4..	5..	6..	7..	8..	9..	10..	11..	12..
f	1.1	1.2	1.6	1.2	1.4	1.3	1.5	1.3	1.4

PB..2									
Faktör Factor Faktor	Gövde / Size / Größe								
	42	52	62	72	82	92	102	112	122
f	1.0	1.0	1.3	1.0	1.2	1.1	1.3	1.1	1.2

TR

FLANŞ MONTAJI (UZUN)

EN

MOUNTING FLANGE - LONG SPACER

DE

KRAGENFLANSCH

Tablo 2 / Table 2 / Tabelle 2												
											PH.2-S, PH.2-D, PH.2-H PH.3-S, PH.3-D, PH.3-H PH.4-S, PH.4-D, PH.4-H PB.3-S, PB.3-D, PB.3-H PB.4-S, PB.4-D, PB.4-H	PB.2-S, PB.2-D, PB.2-H
Gövde Size Größe 1)	a1	b1 f7	c1	e1	f1	h1	h2	m _{max}	z x s1	Ağırlık Add. weight Zusätz Gewicht. kg	G2/G4 mm	G2/G4
mm											mm	
4..	450	350	24.5	400	5	82.5	50	205	8 x 17.5	40	140	170
5..	550	450	25	500	5	90	52.5	245	8 x 17.5	60	165	200
6..	550	450	25	500	5	90	52.5	245	8 x 17.5	65	165	200
7..	660	550	25	600	5	135	90	290	8 x 22	90	195	235
8..	660	550	30	600	5	135	90	315	8 x 22	100	195	235
9..	660	550	29	600	6	134	84	325	12 x 22	110	235	270
10..	660	550	34	600	6	134	84	355	12 x 26	120	235	270
11..	800	680	44	740	6	184	129	420	12 x 26	210	270	320
12..	800	680	44	740	6	184	129	435	12 x 26	220	270	320

1) T_{2max} ≤ T_{2N} / f

1) T_{2max} ≤ T_{2N} / f

1) T_{2max} ≤ T_{2N} / f

Tablo 3 / Table 3 / Tabelle 3				
İmalat tipleri, büyüklükleri ve uygulama şekilleri. Possible types, sizes designs Mögliche Bauarten, Größen, Ausführungsformen				
Gövde Size Größe	PH..2-H	PH..2-V	PH..3-H, PH..4-H PB..2-H, PB..3-H, PB..4-H	PH..3-V, PH..4-V PB..2-V, PB..3-V, PB..4-V
4..	A + B	B	A + B + C + D	B + C
5..				
6..				
7..				
8..				
9..	A + B + C + D	B + C	A + B + C + D	B + C
10..				
11..				
12..	A + B + C + D	B + C	A + B + C + D	B + C

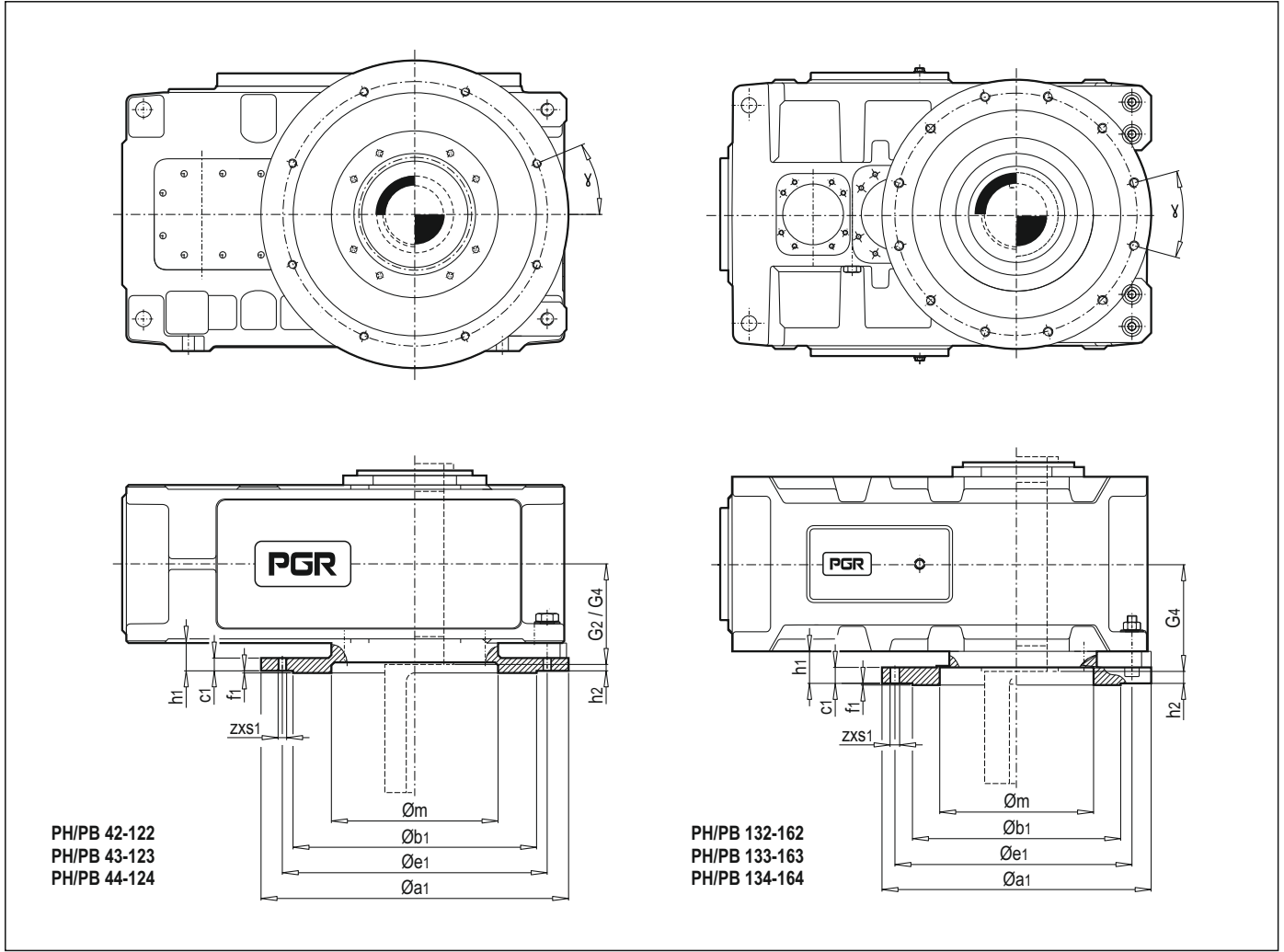

Not:
13...ve üstü gövde büyüklükleri sadece ayaksız şekilde imal edilmektedir.
Bu nedenle M montaj şekline göre uygulanır. Muhtemel uygulama şekilleri için, Tablo 3'e bakın. Kilit veya pompa kombinasyonu, talep üzerine temin edilir.
C ve D tipi tasarımı PH tipi redüktörlerde motor bağlantı adaptörü veya fanının kombinasyonu, talep üzerine temin edilir.

Notes:
From size 13... up, only housing without feet, i.e. Mounting position M, are used.
For possible designs, see table 3. Combination with backstop or pump on request.
Combination with motor bell housing or fan for PH gear units of C and D design on request.

Hinweise:
Ab Größe 13 werden nur Gehäuse ohne Fuß, d.h.in Einbaulage M eingesetzt.
Mögliche Ausführungsformen siehe Tabelle3.
Kombinationen mit Rücklaufperre oder Pumpe auf Anfrage.
Kombinationen mit Motorlaterne oder Lüfter bei PH Getrieben der Ausführungsformen C und D auf Anfrage.

Tablo 1 / Table 1 / Tabelle 1													
Moment faktörü f / Torque factor f / Drehmomentfaktor f													
PH..2, PH..3, PH..4, PB..3, PB..4													
Faktör Factor Faktor	Gövde / Size / Größe												
	4..	5..	6..	7..	8..	9..	10..	11..	12..	13..	14..	15..	16..
f	1.1	1.2	1.5	1.2	1.4	1.3	1.5	1.3	1.4	1.4	1.1	1.4	1.2

PB..2													
Faktör Factor Faktor	Gövde / Size / Größe												
	42	52	62	72	82	92	102	112	122	132	142	152	162
f	1.0	1.0	1.2	1.0	1.2	1.1	1.3	1.1	1.2	1.2	1.0	1.2	1.0

Tablo 2 / Table 2 / Tabelle 2													
Tip Type Bauart	Gövde Size Größe 1)	a1	b1 f7	c1	e1	f1	h1	h2	mmax	z x s1	Add. weight Zusätz. Gewicht kg	PH.2-S, PH.2-D, PH.2-H PH.3-S, PH.3-D, PH.3-H PH.4-S, PH.4-D, PH.4-H PB.3-S, PB.3-D, PB.3-H PB.4-S, PB.4-D, PB.4-H	PB.2-S, PB.2-D, PB.2-H
												G2/G4	G2/G4
mm											mm		
S D, H	4..	445	340	25	400	5	55	22.5	205	8 x M16	35	140	170
	5..	565	430	25	515	5	60	22.5	245	8 x M16	55	165	200
	6..	565	430	25	515	5	60	22.5	245	8 x M16	55	165	200
	7..	670	530	25	620	5	60	15	295	8 x M20	80	195	235
	8..	670	530	40	620	5	80	35	300	8 x M20	110	195	235
	9..	670	530	35	620	5	80	30	320	12 x M20	105	235	270
	10..	730	560	35	680	5	80	30	355	12 x M24	125	235	270
	11..	730	560	40	680	5	90	35	400	12 x M24	145	270	320
S D, H	13..	840	650	50	760	5	100	37.5	450	12 x M30	245	335	390
											240		-
S D, H	14..	840	650	50	760	5	100	37.5	480	12 x M30	255	335	390
											245		390
S D, H	15..	960	750	50	880	5	100	30	530	16 x M30	315	380	460
											305		-
S D, H	16..	960	750	50	880	5	100	30	540	16 x M30	320	380	460
											315		450

1) T2max ≤ T2N / f

1) T2max ≤ T2N / f

1) T2max ≤ T2N / f

Tablo 3 / Table 3 / Tabelle 3						
Muhtemel imalat tipleri, büyüklükleri ve uygulama şekilleri. Possible types, sizes, designs / Mögliche Bauarten, Größen Ausführungsformen						
Gövde Size Größe	PH..2-SH, PH..2-HH PH..2-DH	PH..2-V	PH.3-SH, PH.4-SH, PB.2-SH, PB.3-SH, PB.4-SH PH.3-HH, PH.4-HH, PB.2-HH, PB.3-HH, PB.4-HH PH.3-DH, PH.4-DH, PB.2-DH, PB.3-DH, PB.4-DH	PH.3-V, PH.4-V PB.2-V, PB.3-V, PB.4-V		
4..	A + B	B	A + B + C + D	B + C		
5..						
6..						
7..						
8..						
9..						
10..					A + B + C + D	B + C
11..					A + B	B
12..					A + B + C + D	B + C
13..	A + B	B	A + B + C + D	B + C		
14..	A + B + C + D	B + C				
15.. 2)						
16.. 2)						

2) PB152 ve 162 büyüklüğündeki gövdelerde A veya C dizaynı yapılamamaktadır.

2) Design A or C not possible for type PB152- 162 sizes 15 + 16!

2) Bauart PB152-162..Größe 15 + 16 nicht in Ausführung A oder C möglich!

TR

FAN SOĞUTMASI

Eğer redüktörde fan opsiyonu var ise, soğutma fanı giriş milinin sonuna mil faturasına dayanacak şekilde takılmıştır. Bu opsiyon ile elde edilen artırılmış soğutma etkisi termal kapasite değeri Pt1 ile gösterilmiştir. Bakınız sayfa 70...92

Fanın verimliliği $n1=900$ d/d'den düşük olduğu hızlarda büyük oranda azalır. Bu durum şöyle olmalı ki, mekanik güç, termal kapasiteden büyük olduğunda sıcaklık dağıtımını arttıran cihaz yerine serpantin tavsiye edilmelidir.

EN

FAN COOLING

If the fan option is specified, a cooling fan is keyed to the end of the input shaft the drive side. The increased cooling effect obtained by this option is shown by the thermal capacity value Pt1. See the section, 70...92.

The efficiency of the fan is greatly reduced at drive speed lower than $n1=900$ min⁻¹. Should this be the case the cooling coil is recommended instead the device the best increases the heat dissipation when the mechanical power is greater than thermal capacity.

DE

LUFTERKUHLUNG

Eine Verstärkte Wärmeableitung erhält man bei Verwendung von Lüftern, die an der Antriebswelle des Getriebes aufgezogen werden. Die erhöhte Kühlwirkung mit Option ist die Wärmekapazität welche als Pt1 dargestellt Siehe Seite 70...92.

Wenn die Geschwindigkeit niedriger als $n1=900$ min⁻¹ im betrieb ist verringert sich die Effizienz der Zwangslüftung. Um die Wärmeleistung des Getriebes zu erhöhen, wird in diesem Fall separate Kühlschlange empfohlen.

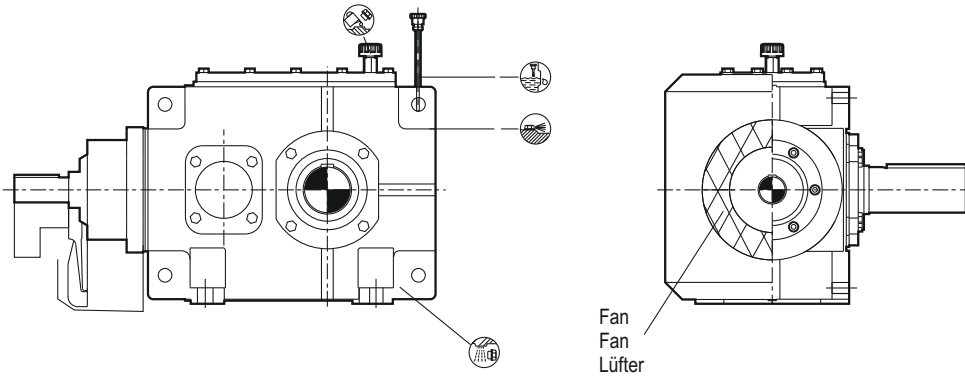

TR

SOĞUTMA BOBİNİ (SERPANTİN)

Soğutma bobin opsiyonu fabrikamızdan temin edilerek soğutma devresine entegre edilmesi için dizayn edilmiştir. Su kaynağı devresi takip eden özelliklerde olmalıdır: maksimum basınç 8 bar, akış hızı 5 l/dk, maksimum dolaşım sıcaklığı 20°C olmalıdır. Bakınız sayfa 70...92.

EN

COOLING COIL

The cooling coil option is designed for integration in a cooling circuit to be provided by the installer. The water supply circuit must correspond to the following specifications: maximum pressure 8 bar, flow rate 5 l/min, maximum delivery temperature 20°C. The increased cooling effect obtained in these conditions is shown by the thermal capacity value See the section 70...92.

DE

KUHLSCHLANGE

Die Kühlschlange ist für den Einbau in einen Kühlkreis vorgesehen, der von Monteur realisiert werden muss. Das Wasserversorgungsnetz muss folgende Spezifikationen erfüllen: Druck max. 8 bar, Durchsatz 5 l/Min, Auslasstemperatur max. 20°C. Die erhöhte Kühlwirkung unter diesen Bedingungen ist durch den Wert der Wärmeleistung Seite 70...92 angegeben.

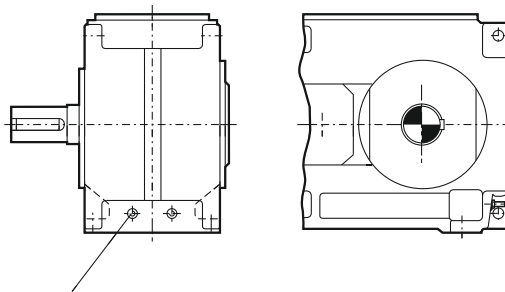

x) Gereki soğutma suyu miktarı; basıncı 8 bar
Cooling water quantity required, max. cooling water pressure: 8 bar
Erforderliche Kühlwassermenge, max. kühlwasserdruck: 8 bar

TR

ISITICILAR

Çok düşük ortam sıcaklıklarında çalışmadan önce ve/veya çalışma esnasında yağ haznesindeki yağlama maddesini önceden ısıtmak gerekebilir. Bu opsiyon bir elektriksel ısıtma elemanının kurulumunu öngörür, düzgün çalışmayı sağlamak için minimum sıcaklığın zamanını saptamak için bir termostat ile tedarik edilir. Termostat için gerekli olan elektrik bağlantısı / elektrik tertibatı / kablolama kurulumcu tarafından sağlanmalıdır. Sayfa 157.

EN

HEATERS

In very low ambient temperatures it may prove necessary to pre-heat the lubricant in the sump before start-up and/or during operation. The option envisages the installation of an electrical heating element, supplied with a thermostat to detect when the minimum temperature needed for correct operation has been reached. The wiring necessary for the thermostat must be provided by the installer.

DE

HEIZSTÄBEN

Bei sehr niedrigen Umgebungstemperaturen kann es sich als erforderlich erweisen, das Schmiermittel im Gehäuse vor Inbetriebnahme und/oder während des Betriebs vorzuwärmen. Die Option Heizstäben siehe Seite 157 sieht die Installation eines elektrischen Heizwiderstands und die Lieferung eines Thermostats vor, mit dem das Erreichen der erforderlichen Mindesttemperatur für einen korrekten Betrieb angezeigt wird. Die Verkabelung ist vom Monteur vorzunehmen.

TR

BASINÇLI YAĞLAMA

Sürekli çalışma uygulamalarında ve dikey montaj pozisyonu kurulumlarında, opsiyonel olarak basınçlı yağlama devresi istenildiği üzere mevcuttur, giriş milinin sonunda karşı tarafına tutturulan bir pompa ile tamamlanmıştır. Sistem rulmanların üstüne yeterli miktarda yağlama güvencesini verir. Bu opsiyon çift giriş millî konfigürasyonlar için uygun değildir. Bakınız sayfa 100...112.

EN

FORCED LUBRICATION

In continuous duty applications and vertical mounting position installations, an optional forced lubrication circuit is available on request, complete with a pump keyed to the shaft end opposite the drive side. This system ensures adequate lubrication of the top bearings. This option is not available with other configurations that use the same shaft end.

DE

ZWANGSSCHMIERUNG

Bei Dauerbetrieb und vertikalen Anwendungen ist Optional nach Anfrage Zwangsschmierung mit Mechanische Pumpe Verfügbar. Die Applikation der Schmierung ist an der Gehäuse die in der Nähe Antriebswelle ist dabei sorgt dieses system ausreichende Schmierung der oberen Antriebslagerungen. Diese Anwendung ist bei doppel Antriebswelle nicht Verfügbar siehe Seite 100...112.

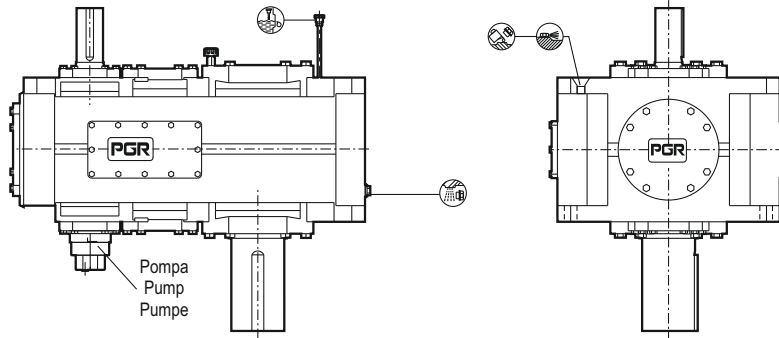

TR

MOTOR POMPASI

Aralıklı çalışma uygulamaları ve dikey montaj pozisyon kurulumları için, basınçlı yağlama devresi talep üzerine mevcuttur, güçlendirilmiş motor pompası ile tamamlanmıştır. Bu sistem rulmanların üstüne sabit yağ akışı güvencesi verir. Bakınız sayfa 100...124.

EN

MOTOR PUMP

For intermittent duty applications and vertical mounting position installations, a forced lubrication circuit is available on request, complete with an independently powered motor pump. This system ensures a constant oil flow to the top bearings. Specify the Motor pump option. Option Motor pump is not available if fan cooling - option FAN is also specified. See the section 100...124.

DE

MOTORPUMPE

Bei periodische Anwendung Baulage Vertikal, Optional nach Anfrage Hydraulische Pumpe mit separaten Elektromotor Verfügbar. Dieses system sorgt ausreichende Schmierung der oberen Antriebslagerungen siehe Seite 100...124.

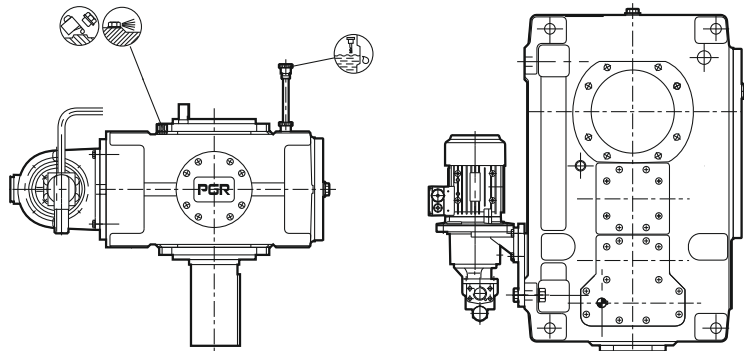

Yardımcı Tahrikli Redüktörler

Bucket Elevator Drives

Becherwerksantriebe

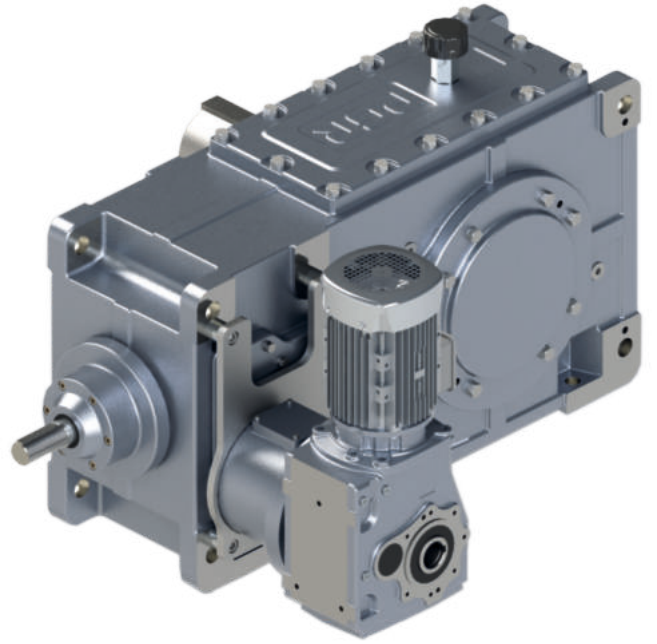



A series of horizontal dotted lines spanning the width of the page, intended for writing or drawing.

TR YARDIMCI TAHRİKLİ REDÜKTÖRLER

EN BUCKET ELEVATOR DRIVES

DE BECHERWERKSANTRIEBE

PB...3-SH

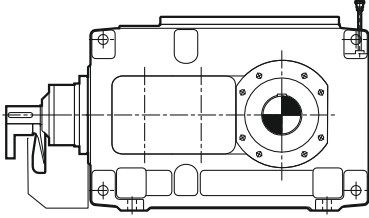

PB...3-HH

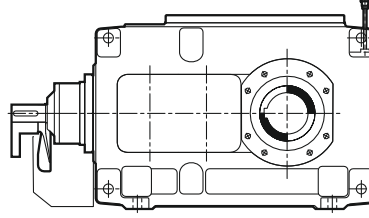

PB...3-DH

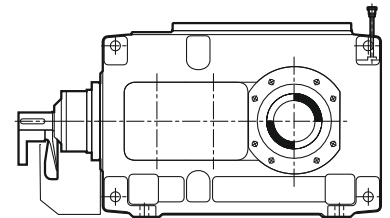

Yardımcı Tahrikli Redüktörler

Temel Tipler
Helisel-Konik dişli redüktör

Tip PB...3-H, 3-kademe

Boyut 43 ... 123
Monoblok gövde
Boyut 133 ... 183
İki parçalı gövde

Bucket Elevator Drives

Summary of Basic Types
Bevel-helical gear units

Type PB...3-H, 3-stage

Sizes 43 ... 123
Solid housing
Sizes 133 ... 183
Split housing

Becherwerksantriebe

Bauartenübersicht
Kegelstirnradgetriebe

Bauart PB...3-H, 3-stufig

Größen 43 ... 123
Ungeteiltes Gehäuse
Größen 133 ... 183
geteiltes Gehäuse

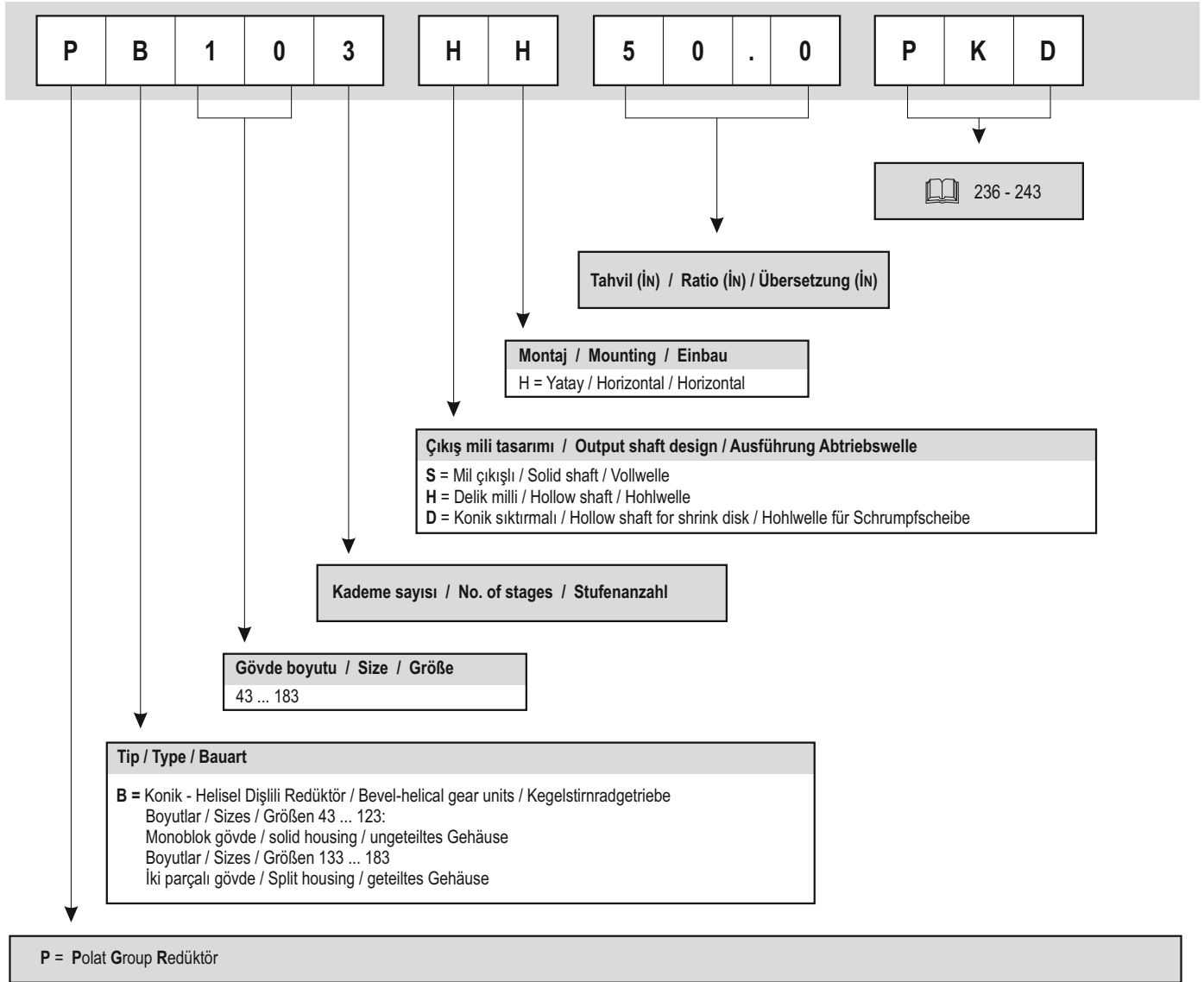
**Sipariş verirken gerekli ek bilgiler:**Çevirim oranı i , tasarım B, D, v.b.

Çıkış milinin alınından bakıldığında, çıkış milinin dönüş yönü ile yardımcı redüktörün ana redüktöre bağlandığı milin dönüş yönü aynıdır.

Further details required in orders:Transmission ratio i , designs B, D, etc.Direction of rotation of output shaft d_2 when looking at shaft end face in case of input via main as well as auxiliary drive**Weitere bei Bestellung notwendige Angaben:**Übersetzung i , Ausführungen B, D usw.Drehrichtung der Abtriebswelle d_2 bei Sicht auf Wellenspiegel bei Antrieb über den Haupt - als auch Hilfsantrieb**Örnek: PB103-HH-**Konik-helisel dişli ünitesi, 3 kademe, B tasarımı, $i=50$, delik milli dizayn, yatay montaj pozisyonu, gövde büyüklüğü 10 yardımcı sürücülü (yük altında operasyon) d_2 shaft dönüş yönü CCW**Example PB103-HH**Bevel-helical gear unit, 3-stage, design B, $i=50$, hollow shaft design, horizontal mounting position, size 10 with auxiliary drive (operation under load), rotation of shaft d_2 CCW**Beispiel PB103-HH**Kegelstirnradgetriebe 3-stufig, Ausführung B, $i=50$, Abtrieb in hohlwellenausführung, Horizontale Einbaulage, Größe 10 mit Hilfsantrieb (Lastbetrieb), Welle d_2 linksdrehend

TR KARAKTERİSTİK ÖZELLİKLER**İmalat**

PGR dişli redüktörleri, tamamen yeniden dizayn edildi. Üstün yenilikleri:

- Daha az parça çeşitliliği ile, daha fazla gövde büyüklüğü,
- Artan güç kapasitesi ile daha yüksek işletme şartlarında güvenli çalışma,
- Redüktör montajını kolaylaştıran ve daha az yer gerektiren flanşlı çıkış milleri (Sipariş üzerine temin edilir).

Montaj Pozisyonları

PGR dişli redüktörleri, yatay montajlı şekilde teslim edilir.

Redüktörün yağ miktarının ve yağ çubuğu uzunluğunun ayarlanması hariç aşağıdaki eğimleri başka bir işlem olmadan yapmak mümkündür.

Uzunlamasına $\leq \pm 5^\circ$
Yanlamasına $\leq \pm 2^\circ$

Talep edildiğinde, diğer düzenlemelerin uygulanması mümkündür. Müşteri talebi üzerine seçilen redüktörlere örneğin motor bağlantı adaptörü, redüktör tabanı titreme önleyici ve tork kolu kilit v.b. farklı donanımların eklenmesi mümkündür.

Gürültü Seviyesi

PGR dişli redüktörlerinde, gürültü seviyesini kesinve kalıcı bir şekilde azaltmak için yapılanlar:

- Konik dişliler taşlanır,
- CNC bilgisayar programıyla, gürültü seviyesini azaltacak şekilde gövde ve yüksek kalitede dişliler işlenmektedir.
- Son derece geniş bir temas yüzeyi sağlanır.

Isı İletkenliği

PGR redüktörlerin sadece yüksek verimlilikleri değil ısı iletkenlikleri de uygundur.

Redüktör seçiminde PGR, gereken en düşük maksimum yağ sıcaklığını temel olarak alır. Bu sayede, işyeri güvenliği artar ve yağlama aralıklarının daha uzun olması nedeniyle, bakım masrafları da azalır.

Depolama

PGR dişli redüktörleri, yeni bir modüler sisteme göre tasarlandı. Bu sayede, farklı montaj parçalarının sayısı azaltıldı. İlgili montaj parçalarının oldukça büyük bölümü, stoklarımızda mevcuttur.

EN CHARACTERISTIC FEATURES**Design**

PGR gear units are a completely new design. Outstanding innovations are:

- more sizes with a reduced variety of parts;
- higher operational reliability combined with increased power capacity;
- flanged output shafts to facilitate assembly of gear units in confined spaces (on request).

Mounting position

PGR gear units are available for horizontal installation.

The following inclinations are possible without any additional measures, with the exception of the adjustment of the oil quantity and the length of the oil dipstick:

Longitudinal $\leq \pm 5^\circ$
Lateral $\leq \pm 2^\circ$

Other arrangements are also possible on request. Motor bell housings, gear unit swing-bases, and torque supports are part of our standard product range.

Noise behaviour

New concepts were applied to clearly improve the noise emission of the gear units by:

- grinding the bevel gears;
- designing noise - absorbing housings by means of the CNC computing program; and
- achieving exceptionally large contact ratios.

Thermal conduction

PGR gear units not only have a high efficiency but also a favourable thermal conduction.

The selection of PGR gear units is based on a lower maximum oil temperature. By that, the operational reliability will be increased and the cost of maintenance reduced due to longer oil change intervals.

Storing

PGR gear units have been designed according to a new unit construction principle. Through this, the variety of parts could be reduced.

DE CHARAKTERISTISCHE VORZÜGE**Konstruktion**

PGR - Zahnradgetriebe wurden völlig neu konzipiert. Pluspunkte sind:

- mehr Baugrößen bei weniger Bauteilvarianten,
- höhere Betriebssicherheit bei gesteigerter Leistungsdichte,
- Flanschabtriebswellen zur leichteren Getriebemontage bei kleinem Raumbedarf (auf Anfrage).

Einbaulage

PGR - Zahnradgetriebe sind für horizontale Einbaulage lieferbar.

Ohne Zusatzmaßnahmen, bis auf die Anpassung von Ölmenge und Ölmesstablänge, sind folgende Getriebeneigungen möglich:

Längsneigung $\leq \pm 5^\circ$
Querneigung $\leq \pm 2^\circ$

Auch andere Anordnungen sind nach Rücksprache möglich. Motorlaternen, Getriebschwingen und Drehmomentstützen gehören zum Standardprogramm.

Geräuschverhalten

Bei PGR - Zahnradgetrieben konnte das Geräuschverhalten entscheidend verbessert werden. Dazu wurden:

- die Kegelräder geschliffen,
- die geräuschdämpfenden Gehäuse mit CNC - Rechenprogramm entwickelt und
- außergewöhnlich hohe Überdeckungsgrade der Verzahnung erreicht.

Temperaturverhalten

PGR - Zahnradgetriebe haben bei einem guten Wirkungsgrad ein günstiges Temperaturverhalten.

Bei der Getriebeauswahl legt PGR eine niedrige maximale Öltemperatur zugrunde. Die Betriebssicherheit wird dadurch erhöht, und der Wartungsaufwand verringert sich durch längere Ölstandszeiten.

Vorratshaltung

PGR-Zahnradgetriebe sind nach einem neuen Baukastensystem konstruiert. Dadurch konnte die Zahl der Bauteilvarianten reduziert werden.

TR





GENEL BİLGİLER

Dikkat!

Aşağıda belirtilen unsurlara mutlaka dikkat edilmelidir!

- Burada yer alan resim ve çizimler sadece örnek olarak gösterilmiştir ve bağlayıcı değildir. Firmamızın ölçüleri değiştirme hakkı saklıdır.
- Belirtilen ağırlıklar, ortalama değerlerdir ve bağlayıcı değildir.
- Hareketli parçalara kazayla temas edilmemesi için, alıcı tarafından gereken tedbirler alınmalıdır. İlgili ülkede geçerli ve yürürlükte olan güvenlik yönetmeliklerine, mutlaka dikkat edilmelidir.
- Kullanmaya başlamadan önce, kullanma ve çalıştırma kılavuzu mutlaka incelenmelidir. Redüktörler, kullanıma hazır, ancak yağ doldurulmadan teslim edilir.
- Belirtilen yağ miktarları, sadece önerilen değerlerdir ve bağlayıcı değildir. Bu yüzden, yağ ölçme çubuğuyla tespit edilen yağ seviyesi belirleyicidir.
- Yağ viskozitesi, mutlaka alüminyum etikette belirtilen değere uygun olmalıdır.
- Sadece uygun görülen yağ tipleri kullanılmalıdır. En güncel kullanma kılavuzu ve yağ tipi tabloları, web sitemizde yer almaktadır: www.pgr.com.tr
- Yardımcı redüktörler tarafımızdan sentetik yağ doldurularak gönderilir.
- Redüktörler keçeleri takılı durumda teslim edilir. Diğer sızdırmazlık yöntemleri, talep edildiğinde uygulanır.
- Dönme yönü bilgileri, d2 çıkış miline bağlıdır.

Kullanılan sembollerin açıklamaları:

-  = Yağ ölçme çubuğu
-  = Havalandırma
-  = Yağ boşaltma Noktası
-  = Yağ doldurma Noktası

Gövde büyüklüğü 13 ve üzeri olan redüktörlerde basınç civataları, gövde ayağında ve gövdenin üst kısmındaki ayar yüzeylerinde yer alır.

DIN EN 20273'e göre gövde üzerinde bulunan sabitleme deliklerine vidalanması gereken "kaba" sınıfı taban civatalarının mukavemet sınıfı en az 8.8'dir.

Redüktörlerin korozyona karşı korunması sağlanmış ve RAL 7000 renk tonunda boyanmıştır.

EN





GENERAL INFORMATION

Attention!

The following items are absolutely to be observed!

- Illustrations are examples only and are not strictly binding. Dimensions are subject to change.
- The weights are mean values and not strictly binding.
- To prevent accidents, all rotating parts should be guarded according to local and national safety regulations.
- Prior to commissioning, the operating instructions must be observed. The gear units are delivered ready for operation but without oil filling.
- Oil quantities given are guide values only. The exact quantity of oil depends on the marks on the oil dipstick.
- The oil viscosity has to correspond to the data given on the name plate.
- Permitted lubricants may be used only. You will find current operating instructions and lubricant selection tables on our home page at: www.pgr.com.tr
- Normally, auxiliary gear units are filled with a synthetic lubricant at the factory before dispatch. There is a note on the rating plate: Filled with oil.
- The gear units are supplied with radial shaft seals. Other sealing variants on request.
- Directions of rotation referring to output shaft d2.

Explanation of symbols used in the dimensioned drawings:

-  = Oil dipstick
-  = Breather
-  = Oil drain
-  = Oil filler

From size 13 up jack screws in the housing feet, and leveling pads on the upper housing part.

Foundation bolts of min. property class 8.8. Tolerance of the clearance holes in the housing acc. to DIN EN 20273 "coarse" series.

The gear housings are protected against corrosion and sprayed in RAL 7000.

DE





ALLGEMEINE HINWEISE

Achtung!

Folgende Punkte sind unbedingt zu beachten!

- Abbildungen sind beispielhaft und nicht verbindlich. Maßänderungen bleiben vorbehalten.
- Die angegebenen Gewichte sind unverbindliche Mittelwerte.
- Umlaufende Teile müssen vom Käufer gegen unbeabsichtigtes Berühren geschützt werden. Die gültigen Sicherheitsbestimmungen des jeweiligen Einsatzlandes sind zu beachten.
- Vor Inbetriebnahme ist die Betriebsanleitung zu beachten. Die Getriebe werden betriebsfertig, jedoch ohne Ölfüllung geliefert.
- Ölmengenangaben sind unverbindliche Richtwerte. Maßgebend ist die Ölstandsmarkierung am Ölmesstab.
- Ölviskosität muss den Angaben des Typenschildes entsprechen.
- Es dürfen nur freigegebene Schmierstoffe verwendet werden. Aktuelle Betriebsanleitungen und Schmierstofftabellen finden Sie auf unserer Homepage unter: www.pgr.com.tr
- Im Normalfall werden die Hilfsgetriebe von uns vor dem Versand mit synthetischem Schmierstoff gefüllt. Das Leistungsschild trägt den Hinweis: Mit Öl gefüllt.
- Die Getriebe werden mit Radialwellendichtringen ausgeliefert. Andere Dichtungsvarianten auf Anfrage.
- Drehrichtungsangaben beziehen sich auf die Abtriebswelle d2.

Erklärung der Symbole in den Maßzeichnungen:

-  = Ölmesstab
-  = Entlüftung
-  = Ölablass
-  = Öleinfüllung

Ab Getriebegröße 13 Druckschrauben im Gehäusefuß und Ausrichtflächen auf dem Oberteil des Gehäuses.

Fußschrauben mit Mindest-Festigkeitsklasse 8.8. Toleranz der Befestigungsbohrungen im Gehäuse nach DIN EN 20273 - Reihe "grob".

Die Getriebe sind konserviert und im Farbton RAL 7000 lackiert.

<p>1. Redüktör tipi ve boyutunun belirlenmesi Determination of gear unit type and size Bestimmung von Getriebebauart und Größe</p>	<p>Redüktör Seçimi için kurallar / Guidelines for the Selection / Richtlinien für die Auswahl</p> <p>1.1 Çevrim oranını bulma / Find the transmission ratio / Bestimmung der Übersetzung</p> $i_s = \frac{n_1}{n_2}$ <p>1.2 Dişli ünitesi nominal güç belirleme / Determine nominal power rating of the gear unit / Bestimmung der Getriebennleistung</p> $P_N \geq P_2 \times f_1$ <p>Bize danışmanıza gerek yok; It is not necessary to consult us, if; Rücksprache nicht erforderlich, wenn:</p> $3.33 \times P_2 > P_N$ <p>1.3 Örneğin redüktörün en yüksek çalışma momenti, başlangıç momenti ve frenleme momenti v.b. maksimum momentlerinin kontrol edilmesi Check for maximum torque, e.g. peak operating-, starting- or braking torque Kontrolle auf maximalmoment z.B.: Betriebsspitzen-, Anfahr- oder Bremsmoment</p> $P_N \geq \frac{T_A \times n_1}{9550} \times 0.5$ <p>i_N ve P_N'e göre redüktör gövde büyüklükleri ve kademe sayıları tabloda verilmiştir Gear unit sizes and number of reduction stages are given in rating tables dependig on i_N and P_N Getriebegrößten und Stufenanzahl sind in den Leistungstabellen abhängig von i_N und P_N festgelegt</p> <p>1.4 Öngörülen i gerçek tahvil değerinin, uygun olup olmadığının kontrol edilmesi için sayfa 250'e bakınız. Check whether the actual ratio i as per tables on page 250 is acceptable Prüfung, ob Ist-Übersetzung i geeignet ist, siehe Seite 250</p>
	<p>Yatay montaj pozisyonu / Horizontal mounting position / Einbaulage Horizontal</p>
<p>2. Yağ kaynağının belirlenmesi Determination of oil supply Bestimmung der Ölversorgung</p>	<p>Yağlanması gereken tüm parçalar, yağ içerisinde veya benzer şekilde, sıçramalı yağlama uygulanarak yağlanır. Basıncılı yağlama, ancak istek ve sipariş üzerine temin edilir. All parts to be lubricated are lying in the oil or are splash lubricated Forced lubrication on request Alle zu schmierenden Elemente liegen im Öl bzw. werden mit Spritzöl versorgt Druckschmierung auf Anfrage</p>
<p>3. Gerekli termal kapasitenin belirlenmesi P_t Determination of required thermal capacity P_t Bestimmung der erforderlichen Wärmegrenzleistung P_t</p>	<p>3.1 Redüktörün ilave soğutucusu olmadan yeterli olması için / Gear unit without auxiliary cooling sufficient, if / Getriebe ohne Zusatzkühlung ausreichend, wenn</p> $P_2 \leq P_t = P_{t1} \times f_6$ <p>3.2 Fan soğutmasının redüktör için yeterli olması için / Gear unit with fan sufficient, if / Getriebe mit Lüfter ausreichend, wenn:</p> $P_2 \leq P_t = P_{t2} \times f_6$ <p>3.3 Talep edildiğinde yüksek termal kapasitelerde dış soğutma ünitesi For higher thermal capacities, cooling by external oil cooler on request Für größere Wärmegrenzleistungen Kühlung durch externen Ölkühler auf Anfrage</p>

TR	SEMBOLLER	EN	KEY TO SYMBOLS	DE	ERKLÄRUNG DER BEZEICHNUNGEN
	Semboller		Key to Symbols		Erklärung der Bezeichnungen
E_D	= Saatte çalışma döngüsü %, e.g. ED= 80%/h	E_D	= Operating cycle per hour in %, e.g. ED= 80%/h	E_D	= Einschaltdauer in % (z.B. ED=80% je Stunde)
f_1	= İş makineleri faktörü (Tablo 1) sayfa..	f_1	= Factor for driven machine (table 1), page 9	f_1	= Arbeitsmaschinenfaktor (Tabelle 1), Seite 9
f_6	= Rakım faktörü (tablo 2), page 230	f_6	= Factor for altitude (table 2), page 230	f_6	= Höhenfaktor (Tabelle 2), Seite 230
i	= Gerçek tahvil	i	= Actual ratio	i	= Ist-Übersetzung
i_N	= Nominal tahvil	i_N	= Nominal ratio	i_N	= Nennübersetzung
i_s	= Gereken tahvil	i_s	= Required ratio	i_s	= Soll-Übersetzung
n_1	= Giriş devir sayısı (d/d)	n_1	= Input speed (min ⁻¹)	n_1	= Antriebsdrehzahl (min ⁻¹)
n_2	= Çıkış devir sayısı (d/d)	n_2	= Output speed (min ⁻¹)	n_2	= Antriebsdrehzahl (min ⁻¹)
n_3	= Çıkış şaftı üzerinde bulunan ana dişlinin çıkış devri (d/d) (50 Hz: n1=1500 d/d, 60 Hz, n3 ≈20%) sayfa 235-243 bakınız	n_3	= Output speed (min ⁻¹) on main gear unit output shaft (PB3.H) in case of input via auxiliary drive (50 Hz; n1 = 1500 min ⁻¹ ; at 60 Hz, n3 will be ≈ 20% higher), pages 235-243	n_3	= Antriebsdrehzahl (min ⁻¹) an Abtriebswelle des Hauptgetriebes (PB3.H) bei Antrieb über den Hilfsantrieb (50 Hz, n1=1500 min ⁻¹ ; bei 60 Hz wird n3 ≈20 % höher), Seiten 235-243
P_t	= Gereken termal kapasite	P_t	= Required thermal capacity	P_t	= Erforderliche Wärmegrenzleistung
P_{t1}	= İlave soğutucusu olmayan redüktörlerde termal kapasite (sayfa 232-233'e bakınız)	P_{t1}	= Thermal capacity for gear units without auxiliary cooling, pages 232-233	P_{t1}	= Wärmegrenzleistung für Getriebe ohne Zusatzkühlung, Seiten 232-233
P_{t2}	= Fan soğutmalı redüktörlerde termal kapasite (sayfa 232-233 'e bakınız)	P_{t2}	= Thermal capacity for gear units with fan cooling, pages 232-233	P_{t2}	= Wärmegrenzleistung für Getriebe mit Lüfterkühlung, Seiten 232-233
P_N	= Redüktör nominal gücü (kW) değer tablolarına bakınız (sayfa 231)	P_N	= Nominal power rating of gear unit (kW), see rating tables page 231	P_N	= Getriebenennleistung (kW), siehe Leistungstabellen Seite 231
P_2	= Sürücü makinanın güç oranı (kW)	P_2	= Power rating of driven machine (kW)	P_2	= Leistung der Arbeitsmaschine (kW)
t	= Ortam sıcaklığı (°C)	t	= Ambient temperature (°C)	t	= Umgebungstemperatur (°C)
T_A	= Redüktörün en yüksek çalışma momenti, hareket momenti ve frenleme momenti (Nm) v.b. giriş milinde ortaya çıkan max. dönme momenti	T_A	= Max. torque occurring on input shaft, e.g. peak operating-, starting-or braking torque (Nm)	T_A	= Max. auftretendes Drehmoment an Eingangswelle, z.B.: Betriebsspitzen - Anfahr - oder Bremsmoment (Nm)
T_{2N}	= Nominal çıkış momenti (kNm) (sayfa 234-235 'e bakınız)	T_{2N}	= Nominal output torque (kNm) page 234-235	T_{2N}	= Nenn-Abtriebsdrehmoment (kNm) Seite 234-235
T_3	= Çıkış şaftı (kNm) üzerinde bulunan ana dişlinin (PB3...H) çıkış momenti Yardımcı redüktör tahriği olması durumunda (sayfa 235-243'e bakınız)	T_3	= Output torque (kNm) on main gear unit output shaft (PB3.H) in case of input via auxiliary drive, pages 235-243	T_3	= Abtriebsdrehmoment (kNm) an der Abtriebswelle des Hauptgetriebes (PB3.H) bei Antrieb über den Hilfsantrieb, Seiten 235-243

TR

ÖRNEK SEÇİM HESABI

Bilinen kriterler:

GÜÇ KAYNAĞI

Elektrik motoru: P₁ = 30 kW
Motor devir sayısı: n₁ = 1500 d/d
Max. hareket momenti: T_A = 300 Nm

İŞ MAKİNELERİ

Bantlı elevatör: P₂ = 22 kW
Devir sayısı: n₂ = 35 d/d
Çalışma süresi: 8h / gün
Saatlik çalışma döngüsü: 10
Yardımcı redüktör: n₃ = 3.2 d/d
T₃ = 6.5 kNm

Saat başı çalışma süresi: E_D = 100%
Ortam sıcaklığı: 30°C
Dışarda kurulum: (w ≥ 4 m/s)
Rakım durumu: Deniz seviyesi

REDÜKTÖR TASARIMI

Helisel konik dişli redüktör
Montaj pozisyonu: Yatay
d₂ çıkış mili: Sağ tarafta, tasarım B, milli
d₂ çıkış milinin dönüş yönü: Sol

İstenen:

Redüktör tipi ve boyutu

1. Redüktör tip ve boyut seçimi

1.1 Tahvil oranının hesaplanması

EN

GUIDELINES FOR THE SELECTION
CALCULATION EXAMPLE

Known criteria:

PRIME MOVER

Electric motor: P₁ = 30 kW
Motor speed: n₁ = 1500 min⁻¹
Max. starting torque: T_A = 300 Nm

DRIVEN MACHINE

Band elevator: P₂ = 22 kW
Speed: n₂ = 35 min⁻¹
Duty: 8h / day
Starts per hour: 10
Auxiliary drive: n₃ = 3.2 min⁻¹
T₃ = 6.5 kNm

Operating cycle per hour: E_D = 100%
Ambient temperature: 30°C
Outdoor installation: (w ≥ 4 m/s)
Altitude: sea level

GEAR UNIT DESIGN

Bevel-helical gear unit
Mounting position: horizontal
Output shaft d₂: on right hand side design B
Direction of rotation of output shaft d₂: CCW

Required:

Type and size of gear unit

1. Selection of gear unit type and size

1.1 Calculation of transmission ratio

$$i_s = \frac{n_1}{n_2} = \frac{1500}{35} = 42.9 \quad i_N = 45$$

1.2 Redüktör nominal güç değerinin belirlenmesi

1.2 Determination of the gear unit nominal power rating

1.2 Bestimmung der Getriebennennleistung

$$P_N > P_2 \times f_1 > 22 \times 1.5 = 33.0 \text{ kW}$$

Güç oranı tablolarında P_N = 41kW PB53...H tipindeki redüktör ile yardımcı redüktör PKD 2390 100L/4A seçilir. n₃ = 3.2 d/d ve T₃ = 6.5 kNm.

Selected from power rating table: type PB53...H, with P_N = 41 kW with auxiliary drive PKD 2390 100L/4A n₃ = 3.2 min⁻¹ and T₃ = 6.5 kNm.

Aus Leistungstabelle Bauart PB53...H, mit P_N = 41 kW mit Hilfsantrieb PKD 2390 100L/4A n₃ = 3.2 min⁻¹ und T₃ = 6.5 kNm gewählt.

$$3.33 \times P_2 > P_N \quad 3.33 \times 22 = 73.3 > P_N$$

Bize danışmanıza gerek yok
It is not necessary to consult us
Rücksprache nicht erforderlich

1.3 Başlangıç momenti kontrolü

1.3 Checking the starting torque

1.3 Kontrolle auf Anfahrmoment

$$P_N \geq \frac{T_A \times n_1}{9550} \times 0.5 = \frac{300 \times 1500}{9550} \times 0.5 = 23.6 \text{ kW} \quad P_N = 100 \text{ kW} > 23.6 \text{ kW}$$

2. Termal kapasitenin belirlenmesi

2. Determination of thermal capacity

2. Bestimmung der Wärmegrenzleistung

2.1 Termal kapasite tablosuna göre ilave soğutmasız PB53...H redüktör seçilir.

2.1 Thermal capacity for gear units without auxiliary cooling, acc. to table for type PB53...H

2.1 Wärmegrenzleistung ohne Zusatzkühlung aus Tabelle Bauart PB53...H

$$P_t = P_{t1} \times f_6 \quad P_t = 39.8 \times 1 = 39.8 \text{ kW} \\ P_2 = 22 \text{ kW} < P_t = 39.8 \text{ kW}$$

Redüktöre ilave soğutucuya gerek yoktur.

A gear unit without auxiliary cooling is sufficient!

Getriebe ohne Zusatzkühlung ausreichend!

TR SERVİS FAKTÖRÜ - KULLANIM ALANLARI

EN SERVICE FACTOR - APPLICATION AREAS

DE BETRIEBSFAKTORE - EINSATZGEBIETE

Tablo 1 Müşteri makinaları için faktör f₁Table 1 Factor for driven machines f₁Tabelle 1 Arbeitsmaschinenfaktor f₁

Müşteri Makinaları / Driven Machines / Arbeitsmaschinen			Yük altında etkili günlük çalışma süresi Effective daily operating period underload in hours Tatsächliche tägliche Laufzeit unter Last in Stunden		
			< 0.5	> 0.5-10	> 10
Konveyörler**	Conveyors**	Förderanlagen**			
Kovalı konveyörler	Bucket conveyors	Becherwerke	-	1.4	1.5
Soğutma kulesi fanları	Hauling winches	Förderhaspel	1.4	1.6	1.6
Vinçler	Hoists	Fördermaschinen	-	1.5	1.8
Bantlı konveyörler ≤ 150kW	Belt conveyors ≤ 150kW	Gurtbandförderer ≤ 150kW	1.0	1.2	1.3
Bantlı konveyörler ≥ 150kW	Belt conveyors ≥ 150kW	Gurtbandförderer ≥ 150kW	1.1	1.3	1.4
Yük asansörleri*	Goods lifts *	Lastaufzüge *	-	1.2	1.5
İnsan asansörleri *	Passenger lifts *	Personenaufzüge *	-	1.5	1.8
Levhalı konveyörler	Apron conveyors	Plattenbänder	-	1.2	1.5
Yürüyen merdiven	Escalators	Rolltreppen	1.0	1.2	1.4
Raylı araçlar	Railway vehicles	Schienefahrzeuge	-	1.5	-

Müşteri makinaları için güç seçimi P₂Design for power rating of driven machine P₂Auslegung für Arbeitsmaschinenleistung P₂

*)Seçim, max. moment değerine göre yapılmalı

*) Designed power corresponding to max. torque

*) Auslegung entsprechend dem Maximalmoment

**) Termal kapasite mutlaka gereklidir.

**) A check for thermal capacity is absolutely essential

**) Thermische Überprüfung generell erforderlich

Burada belirtilen değerler, tecrübeyle tespit edilmiş değerlerdir. Burada belirtilen makine veya tertibatlar kapsamında uygulamanız için, genel olarak bilinen imalat ve yük şartlarının geçerli olduğu varsayılır.

Ancak, uygulamanızın normal bilinenlerden farklı olması halinde, ve burada yer verilmemiş iş makineleri için, mutlaka işletmemizle görüşmelisiniz

The listed factors are empirical values. Prerequisite for their application is that the machinery and equipment mentioned correspond to generally accepted design - and load specifications. In case of deviations from standard conditions, please refer to us.

For driven machines which are not listed in this table, please refer to us.

Die aufgeführten Faktoren sind Erfahrungswerte. Ihre Anwendung setzt für die genannten Maschinen oder Anlagen hierfür allgemein bekannte Konstruktions- und Belastungsbedingungen voraus. Bei Abweichung von Normalbedingungen ist Rückfrage erforderlich.

Für nicht aufgeführte Arbeitsmaschinen bitten wir um Rückfrage.

Tablo 2 / Table 2 / Tabelle 2

Rakım faktörü / Factor for altitude / Höhenfaktor f ₆			
Yardımcı soğutma olmayan veya fanlı soğutma / Without auxiliary cooling or with fan cooling / Ohne Zusatzkühlung oder mit Lüfterkühlung			
Faktör Factor Faktor	Rakım (deniz seviyesi üstünde) / Altitude (metres above MSL) / Höhenlage (Meter über N.N)		
	e kadar / up to / bis	e kadar / up to / bis	e kadar / up to / bis
f ₆	1000	2000	3000
	1.0	0.95	0.90

Termal kapasite bilgileri:

Kurulum alanı için verilen değerler
Rakım < = 1000 m
Rüzgar hızı > = 1.4 m/s
(Kurulum yeri: büyük alan)

Notes on the thermal capacities:

The values listed refer to place of installation
Altitude < = 1000 m
Wind velocity > = 1.4 m/s
(Place of installation: large halls)

Hinweise zu den Wärmegrenzleistungen:

Die angegebenen Werte gelten für den
Aufstellungsort < = 1000 m
Windgeschwindigkeit > = 1.4 m/s
(Aufstellungsort: große Hallen)

TR NOMİNAL GÜÇ DEĞERLERİ P_{2N} (kW)

EN NOMINAL POWER RATINGS P_{2N} (kW)

DE NENNLEISTUNGEN P_{2N} (kW)

iN	n1 min ⁻¹	n2 min ⁻¹	Redüktör Gövdeleri / Gear unit sizes / Getriebegrößen														
			43	53	63	73	83	93	103	113	123	133	143	153	163	173	183
25.0	1800	72.0	51.0	89.0	118	166	209	274	337	488	594	697	868	1176*	1330*	1537*	1845*
	1500	60.0	43.0	73.0	99.0	139	173	228	281	406	495	580	723	980	1108	1281	1537
	1200	48.0	34.0	59.0	79.0	111	139	183	224	325	396	464	578	784	886	1025	1230
	1000	40.0	29.0	49.0	65.0	92.0	115	152	187	270	329	387	482	653	738	854	1025
28.0	1800	64.0	45.0	79.0	105	148	186	224	299	434	527	619	772	1046*	1182*	1367*	1640*
	1500	54.0	38.0	66.0	89.0	124	156	205	252	366	445	522	651	882	998	1153	1384
	1200	43.0	31.0	53.0	70.0	99.0	124	163	201	291	354	416	518	702	794	918	1102
	1000	36.0	26.0	44.0	59.0	83.0	104	137	168	244	297	348	434	588	665	768	922
31.5	1800	57.0	40.0	70.0	94.0	132	165	217	266	387	469	552	687	931*	1053*	1217*	1461*
	1500	48.0	34.0	59.0	79.0	111	139	183	224	325	396	464	578	784	886	1025	1230
	1200	38.0	27.0	47.0	62.0	88.0	110	145	177	257	313	367	458	620	702	811	973
	1000	32.0	22.0	39.0	52.0	73.0	93.0	121	149	216	263	309	386	522	591	683	820
35.5	1800	51.0	36.0	62.0	84.0	117	148	194	238	346	420	494	615	833*	941*	1089*	1307
	1500	42.0	30.0	52.0	69.0	97.0	121	160	196	285	346	406	506	685	775	897	1076
	1200	34.0	23.0	42.0	56.0	79.0	98.0	130	158	231	279	328	410	555	627	726	871
	1000	28.0	19.0	35.0	46.0	64.0	81.0	106	131	190	231	270	338	457	517	598	717
40.0	1800	45.0	32.0	55.0	74.0	104	131	171	210	305	370	436	543	734*	831*	961*	1153*
	1500	38.0	27.0	47.0	62.0	88.0	110	145	177	257	313	367	458	620	702	811	973
	1200	30.0	21.0	37.0	49.0	69.0	87.0	114	140	203	247	290	361	490	554	641	768
	1000	25.0	17.0	31.0	41.0	57.0	72.0	95.0	116	169	206	242	301	408	461	533	641
45.0	1800	40.0	29.0	49.0	65.0	92.0	115	152	187	270	329	387	482	653*	738*	854*	1025*
	1500	33.0	23.0	41.0	54.0	75.0	95.0	125	154	223	271	319	398	539	609	705	846
	1200	27.0	18.0	33.0	44.0	62.0	78.0	102	125	183	222	261	325	441	499	576	692
	1000	22.0	15.0	27.0	36.0	50.0	63.0	84.0	102	149	181	212	265	359	406	469	563
50.0	1800	36.0	26.0	44.0	59.0	83.0	104	137	168	224	297	348	434	588	665*	768*	922
	1500	30.0	21.0	37.0	49.0	69.0	87.0	114	140	203	247	290	361	490	554	641	768
	1200	24.0	16.0	30.0	39.0	55.0	69.0	91.0	112	162	198	232	289	392	443	512	615
	1000	20.0	14.0	24.0	33.0	46.0	57.0	75.0	93.0	135	164	193	241	326	369	426	512
56.0	1800	32.0	22.0	39.0	52.0	73.0	93.0	121	149	216	263	309	386	522	591	683*	820*
	1500	27.0	18.0	33.0	44.0	62.0	78.0	102	125	183	222	261	325	441	499	576	692
	1200	21.0	14.0	26.0	35.0	48.0	60.0	80.0	98.0	142	172	203	253	343	388	448	538
	1000	17.9	12.0	21.0	30.0	41.0	51.0	67.0	84.0	121	147	173	215	292	330	381	458
63.0	1800	29.0	20.0	35.0	48.0	65.0	84.0	110	136	196	239	281	350	473	536	619*	743*
	1500	24.0	16.0	29.0	39.0	54.0	69.0	91.0	112	162	198	232	289	392	443	512	615
	1200	19.0	13.0	22.0	31.0	43.0	55.0	72.0	89.0	129	156	184	228	310	351	405	487
	1000	15.9	10.0	18.0	26.0	36.0	46.0	60.0	73.0	107	131	154	192	259	294	339	407
71.0	1800	25.0	17.0	29.0	41.0	53.0	72.0	91.0	116	160	206	242	301	408	461	533*	641*
	1500	21.0	14.0	24.0	35.0	44.0	60.0	75.0	98.0	134	172	203	253	343	388	448	538
	1200	16.9	11.0	19.0	28.0	36.0	49.0	61.0	79.0	108	139	163	203	275	312	360	432
	1000	14.1	10.0	16.0	22.0	30.0	41.0	51.0	65.0	90.0	115	136	169	230	260	301	361

■ Talep edildiğinde basınçlı yağlama

■ Forced lubrication required

■ Druckschmierung erforderlich

□* Talep edildiğinde yapılan redüktörler

□* Gear units only on request

□* Getriebe nur auf Anfrage

TR TERMAL KAPASİTELER

EN THERMAL CAPACITIES

DE WÄRMEGRENZLEISTUNGEN

n₁:1500min⁻¹

Boyut Size GröÙe	Tahvil Ratio Über-setzung	Thermal kapasite kW (Ortam sıcaklığı) Thermal capacity in kW (Ambient temperature) Wärmegrenzleistung in kW (Umgebungstemperatur)							
		Fansız / without fan / ohne Lüfter				Fanlı / with fan / mit Lüfter			
		20°C	30°C	40°C	50°C	20°C	30°C	40°C	50°C
43	25	42.1	36.1	29.8	23.1	88.4	76.7	64.6	52.0
	28	41.1	35.3	29.2	22.7	85.3	74.1	62.3	50.4
	31.5	39.5	33.9	28.1	22.0	81.3	70.5	59.3	48.1
	35.5	37.7	32.5	27.0	21.3	76.8	66.7	56.1	45.6
	40	33.4	28.8	24.0	19.0	66.6	57.8	48.7	39.8
	45	32.6	28.2	23.5	18.6	65.0	56.5	47.7	38.6
	50	34.3	29.8	25.3	20.5	65.7	57.4	48.9	39.9
	56	31.4	27.3	23.2	18.9	59.6	52.0	44.4	36.2
63	30.1	26.2	22.2	18.1	56.7	49.6	42.2	34.5	
71	27.4	24.0	20.3	16.5	51.3	44.9	38.1	31.2	
53	25	58.7	50.0	41.0	31.5	133	114	96.4	77.6
	28	57.5	49.1	40.4	31.3	128	111	93.5	75.2
	31.5	55.3	47.3	39.2	30.3	122	106	89.0	72.1
	35.5	53.0	45.6	37.7	29.6	115	99.9	84.0	68.3
	40	47.2	40.7	33.8	26.5	100	87.1	73.5	59.7
	45	46.2	39.8	33.0	26.1	97.6	84.7	71.6	58.1
	50	47.3	41.2	34.7	28.1	96.3	84.0	71.2	58.2
	56	43.7	37.9	32.0	25.9	87.8	76.6	65.2	53.2
63	41.9	36.4	30.9	25.0	83.6	73.0	62.1	50.6	
71	39.6	34.4	29.2	23.7	78.1	68.1	58.0	47.3	
63	25	67.2	57.1	46.5	35.6	150	131	109	87.4
	28	66.7	56.8	46.6	35.8	148	129	107	86.6
	31.5	64.3	55.0	45.2	35.0	141	122	103	83.0
	35.5	62.9	54.0	44.7	34.7	136	118	99.7	80.4
	40	60.5	52.0	42.9	33.7	130	112	94.9	76.8
	45	58.0	49.9	41.5	32.7	122	106	89.6	72.9
	50	51.6	44.5	37.0	29.3	107	92.7	78.3	63.8
	56	50.3	43.4	36.2	28.7	104	90.0	76.0	61.8
63	51.4	44.7	37.8	30.6	102	89.1	75.9	62.0	
71	47.2	41.2	34.9	28.4	93.0	81.4	69.3	56.6	
73	25	82.8	69.9	56.1	41.6	190	164	137	109
	28	80.0	67.6	54.9	41.3	180	156	131	104
	31.5	77.2	65.4	53.2	40.6	171	148	123	99.3
	35.5	74.2	63.1	51.4	39.5	162	141	117	94.5
	40	65.7	56.1	46.1	35.5	141	121	102	82.2
	45	64.0	54.7	45.1	35.0	136	117	99.1	79.7
	50	66.3	57.4	47.9	38.3	136	117	99.8	81.0
	56	61.3	53.0	44.5	35.5	123	108	91.2	74.2
63	58.9	50.9	42.7	34.2	118	103	86.8	71.0	
71	55.3	47.9	40.3	32.2	110	95.7	81.0	66.0	
83	25	95.5	80.1	64.2	47.1	216	186	155	123
	28	93.4	78.7	63.5	47.2	209	181	151	119
	31.5	92.0	77.9	63.3	47.9	202	174	146	117
	35.5	88.4	75.3	61.3	47.1	191	165	139	111
	40	85.3	72.6	59.3	45.7	182	157	133	106
	45	81.6	69.9	57.6	44.6	171	149	125	101
	50	72.3	61.9	51.3	39.9	149	130	109	87.8
	56	70.3	60.4	49.9	39.0	144	125	106	84.8
63	72.4	62.7	52.7	42.2	144	124	106	86.2	
71	66.9	58.0	48.8	39.2	132	114	96.7	79.2	
93	25	108	90.1	71.0	50.6	264	227	189	149
	28	106	88.4	70.5	51.5	253	217	181	144
	31.5	103	86.4	69.4	51.5	242	209	174	139
	35.5	99.0	83.7	67.8	51.0	227	197	164	132
	40	93.6	79.5	64.8	49.2	212	184	153	122
	45	87.2	74.2	60.6	46.2	195	169	142	113
	50	90.5	77.9	64.7	51.0	194	168	142	115
	56	83.2	71.7	59.6	47.1	175	153	129	104
63	79.9	68.7	57.3	45.4	167	145	122	99.2	
71	74.1	64.0	53.2	42.2	153	134	113	91.1	
103	25	115	94.7	73.3	50.3	285	244	202	158
	28	113	93.5	73.3	51.1	275	237	196	154
	31.5	112	93.8	74.3	54.3	264	227	189	150
	35.5	109	91.8	73.4	54.9	252	217	182	144
	40	106	89.7	72.6	54.6	242	208	174	139
	45	102	86.6	70.7	53.8	227	197	165	133
	50	96.8	82.2	67.1	51.6	212	184	154	123
	56	90.3	76.8	62.8	48.5	196	169	142	114
63	92.9	80.2	66.9	52.9	194	168	142	115	
71	85.5	73.8	61.7	49.0	176	153	130	105	
113	25	150	121	92.1	59.6	439	375	311	244
	28	148	121	93.3	63.4	420	360	300	236
	31.5	146	120	94.5	66.6	402	345	288	227
	35.5	144	119	93.6	67.0	387	334	277	220
	40	139	115	91.9	66.7	365	315	262	209
	45	130	108	86.8	63.6	338	291	243	194
	50	140	119	98.2	76.2	337	292	246	200
	56	129	110	91.4	71.3	307	266	225	183
63	124	107	88.5	69.6	292	254	214	173	
71	115	99.1	82.4	65.0	267	233	196	159	

Boyut Size GröÙe	Tahvil Ratio Über-setzung	Thermal kapasite kW (Ortam sıcaklığı) Thermal capacity in kW (Ambient temperature) Wärmegrenzleistung in kW (Umgebungstemperatur)							
		Fansız / without fan / ohne Lüfter				Fanlı / with fan / mit Lüfter			
		20°C	30°C	40°C	50°C	20°C	30°C	40°C	50°C
123	25	175	140	102	60.7	528	451	371	288
	28	175	143	107	68.5	508	435	360	281
	31.5	175	144	111	76.3	483	415	345	271
	35.5	172	143	112	78.9	462	397	332	261
	40	169	141	112	80.8	441	380	317	252
	45	165	138	110	80.8	425	366	306	244
	50	159	134	107	79.6	402	347	290	232
	56	149	125	101	75.5	369	319	266	214
63	158	136	112	87.8	367	320	269	219	
71	146	125	104	81.9	335	292	247	200	
133	25	199	159	117	72.6	567	486	401	312
	28	196	160	121	79.1	543	465	387	303
	31.5	194	159	123	85.1	519	446	371	293
	35.5	191	158	123	87.1	501	431	359	285
	40	186	154	122	88.0	475	410	343	271
	45	174	145	116	84.2	439	377	315	251
	50	192	163	135	104	449	390	327	266
	56	179	153	125	97.8	411	358	302	245
63	172	148	122	95.4	393	342	289	234	
71	161	139	114	89.5	363	315	267	216	
143	25	214	166	114	58.8	651	552	453	348
	28	218	173	125	73.5	628	537	442	342
	31.5	220	180	137	88.3	599	514	426	334
	35.5	218	179	139	94.5	574	493	409	322
	40	214	177	139	98.4	549	472	393	311
	45	210	175	139	99.5	529	457	380	301
	50	204	170	137	99.9	502	432	362	288
	56	191	160	129	94.9	461	399	333	265
63	208	177	147	114	472	411	347	281	
71	193	165	137	108	434	376	318	258	
153	25	228	168	104	-	743	626	507	381
	28	241	184	121	54.5	731	619	505	383
	31.5	241	191	135	73.0	691	587	481	369
	35.5	240	190	138	79.9	667	567	467	360
	40	235	189	141	87.2	633	542	448	347
	45	223	182	137	88.7	585	502	415	323
	50	261	220	179	134	612	531	446	357
	56	245	207	169	128	563	487	411	328
63	238	202	165	125	540	467	393	316	
71	226	193	158	122	506	440	369	299	
163	25	227	160	87	-	808	677	544	401
	28	246	186	118	-	768	651	528	400
	31.5	257	198	136	66.8	757	643	524	401
	35.5	255	203	146	83.6	713	608	499	386
	40	254	203	149	90.0	691	590	485	375
	45	248	202	151	97.1	656	561	464	361
	50	235	192	146	97.6	605	519	429	336
	56	272	231	188	142	631	547	460	368
63	255	216	177	135	579	502	424	340	
71	247	210	172	133	555	481	406	326	
173	25	188	107	-	-	941	784	620	447
	28	215	140	57	-	937	782	628	460
	31.5	236	168	94	-	894	753	607	458
	35.5	242	176	106	28.8	866	732	593	450
	40	247	186	122	50.3	828	704	573	437
	45	239	185	124	58.4	769	654	536	410
	50	307	255	201	143	820	708	592	471
	56	292	245	195	143	758	654	549	439
63	286	241	194	143	727	629	528	422	
71	275	233	189	141	685	595	498	401	
183	25	152	59	-	-	992	816	631	440
	28	213	134	-	-	966	807	641	465
	31.5	240	163	80	-	960	806	648	479
	35.5	257	187	112	29.8	913	772	626	472

TR TERMAL KAPASİTELER

EN THERMAL CAPACITIES

DE WÄRMEGRENZLEISTUNGEN

n₁:1800min⁻¹

Boyut Size Größe	Tahvil Ratio Über- setzung	Thermal kapasite kW (Ortam sıcaklığı) Thermal capacity in kW (Ambient temperature) Wärmegrenzleistung in kW (Umgebungstemperatur)							
		Fansız / without fan / ohne Lüfter				Fanlı / with fan / mit Lüfter			
		20°C	30°C	40°C	50°C	20°C	30°C	40°C	50°C
43	25	42.1	35.6	28.9	21.5	99.2	85.7	71.7	57.2
	28	41.3	35.1	28.6	21.6	95.7	82.8	69.5	55.5
	31.5	39.8	33.9	27.6	21.1	91.2	79.1	66.2	53.1
	35.5	38.5	32.7	26.8	20.7	86.3	74.8	62.9	50.6
	40	34.1	29.1	24.0	18.5	75.1	65.1	54.7	44.1
	45	33.4	28.6	23.6	18.4	73.2	63.4	53.4	43.0
	50	35.8	31.0	26.0	21.0	74.7	65.0	55.1	45.0
	56	32.8	28.6	24.0	19.4	67.7	59.0	50.1	40.8
63	31.5	27.3	23.1	18.6	64.4	56.2	47.6	39.0	
71	28.8	25.0	21.0	17.0	58.3	50.8	43.1	35.2	
53	25	57.9	48.6	38.9	28.3	148	128	106	85.1
	28	57.3	48.2	39.0	29.0	144	124	104	83.0
	31.5	55.5	46.8	37.9	28.7	137	118	99.0	79.4
	35.5	53.6	45.5	37.1	28.4	130	112	94.0	75.4
	40	47.9	40.9	33.5	25.7	113	98.0	82.3	66.2
	45	47.0	40.1	32.8	25.4	110	95.2	80.0	64.5
	50	49.2	42.5	35.7	28.5	109	95.1	80.3	65.6
	56	45.5	39.4	32.9	26.4	99.6	86.8	73.6	60.0
63	43.7	37.8	31.7	25.5	94.6	82.6	70.2	57.1	
71	41.3	35.9	30.2	24.3	88.6	77.1	65.4	53.4	
63	25	65.9	55.1	43.7	31.3	167	144	120	95.6
	28	65.9	55.3	44.2	32.1	165	143	119	94.8
	31.5	64.2	54.1	43.7	32.4	158	136	114	91.2
	35.5	63.0	53.4	43.5	32.8	153	132	111	88.9
	40	60.9	51.8	42.2	32.0	146	126	106	85.0
	45	58.8	50.1	41.1	31.7	138	119	100	80.6
	50	52.5	45.0	37.0	28.6	120	104	87.6	70.8
	56	51.4	44.1	36.3	28.1	116	101	85.3	68.9
63	53.6	46.4	38.9	31.2	116	101	85.6	69.6	
71	49.4	42.8	36.0	29.0	105	92.1	78.2	63.8	
73	25	79.6	65.5	50.3	34.3	210	180	149	117
	28	77.7	64.6	50.7	35.7	199	171	143	113
	31.5	75.8	63.0	49.8	35.8	190	163	136	108
	35.5	73.4	61.7	49.4	36.2	181	155	130	103
	40	65.6	55.3	44.4	33.3	157	135	113	90.1
	45	64.2	54.1	43.8	32.7	152	131	109	87.5
	50	68.1	58.5	48.5	38.0	152	132	111	90.3
	56	63.0	54.3	45.0	35.5	140	121	102	82.6
63	60.7	52.2	43.6	34.3	133	115	97.4	78.8	
71	57.2	49.3	40.9	32.4	123	107	90.8	73.5	
83	25	91.0	74.5	57.0	37.6	238	204	168	132
	28	89.8	74.1	57.1	38.8	231	197	163	129
	31.5	89.5	74.6	58.7	41.4	223	192	160	126
	35.5	87.1	73.0	58.1	42.1	211	183	152	120
	40	84.3	71.0	56.6	41.9	202	174	145	116
	45	81.6	69.0	55.5	41.9	192	165	139	110
	50	72.7	61.7	50.0	38.0	166	144	120	96.4
	56	71.0	60.2	49.1	37.3	161	139	116	93.4
63	74.7	64.4	53.6	42.4	161	140	118	96.0	
71	69.2	59.7	49.7	39.5	148	129	108	88.0	
93	25	101	81.8	60.8	38.3	290	247	204	158
	28	100	81.7	62.1	41.0	277	237	196	153
	31.5	98.7	81.1	62.6	42.8	266	227	190	149
	35.5	96.3	80.0	62.6	44.1	252	216	180	142
	40	92.2	76.8	60.6	44.2	235	202	168	134
	45	86.3	72.0	57.1	41.9	216	186	155	123
	50	91.9	78.5	64.3	49.8	215	188	157	126
	56	84.8	72.5	59.6	46.3	196	170	143	115
63	81.4	69.8	57.3	44.7	187	161	136	110	
71	75.8	65.0	53.8	41.8	171	148	125	101	
103	25	106	84.2	60.4	34.4	310	264	216	167
	28	105	84.3	61.7	37.3	301	257	211	163
	31.5	106	86.6	65.9	43.2	290	248	205	160
	35.5	105	85.8	66.5	45.5	276	237	197	154
	40	103	85.3	66.7	46.4	266	228	190	150
	45	100	83.6	66.4	48.0	252	216	181	143
	50	95.8	80.2	64.2	47.1	235	202	168	135
	56	89.8	75.3	60.5	44.5	217	187	156	124
63	94.7	81.2	66.7	51.9	216	188	158	128	
71	87.5	75.0	61.9	48.5	197	171	144	116	
113	25	134	103	69.6	33.2	476	405	332	256
	28	135	105	74.8	40.6	457	390	320	249
	31.5	135	108	78.6	47.2	438	374	308	241
	35.5	135	108	80.4	50.2	423	362	299	235
	40	132	107	81.2	53.2	401	343	285	223
	45	124	101	77.3	52.2	370	318	264	208
	50	140	118	95.7	72.3	373	323	271	218
	56	131	110	89.7	68.5	341	295	249	200
63	126	107	87.5	66.8	325	281	237	191	
71	117	100	81.6	62.9	298	258	216	175	

Boyut Size Größe	Tahvil Ratio Über- setzung	Thermal kapasite kW (Ortam sıcaklığı) Thermal capacity in kW (Ambient temperature) Wärmegrenzleistung in kW (Umgebungstemperatur)							
		Fansız / without fan / ohne Lüfter				Fanlı / with fan / mit Lüfter			
		20°C	30°C	40°C	50°C	20°C	30°C	40°C	50°C
123	25	149	109	66.5	20.9	569	480	390	296
	28	156	118	79.2	35.7	549	466	381	293
	31.5	160	128	90.9	51.2	525	449	369	286
	35.5	160	129	94.6	57.4	504	429	355	277
	40	159	130	97.5	62.6	482	413	342	268
	45	157	129	97.8	65.2	465	399	330	260
	50	153	125	97.4	67.0	441	378	314	248
	56	144	119	92.6	64.9	407	349	291	230
63	159	136	110	84.5	409	354	298	240	
71	148	125	104	79.4	372	323	271	219	
133	25	171	128	81.1	30.7	608	514	418	319
	28	175	136	91.9	44.1	583	496	406	312
	31.5	177	140	100	56.3	560	478	393	305
	35.5	176	141	103	61.5	542	463	381	298
	40	174	141	105	66.7	515	441	364	286
	45	165	135	102	66.7	475	406	337	264
	50	191	160	129	95.7	493	426	358	287
	56	179	151	121	91.7	453	392	329	264
63	173	147	119	90.2	432	375	316	254	
71	163	139	113	86.0	400	347	292	236	
143	25	167	114	55.7	-	686	576	463	343
	28	183	133	78.7	20.4	667	563	457	345
	31.5	197	150	102	48.1	643	547	446	343
	35.5	199	157	110	61.1	615	525	431	334
	40	199	160	118	71.5	592	506	417	325
	45	197	159	119	75.7	573	490	405	316
	50	193	158	120	79.5	544	466	386	303
	56	183	150	115	78.6	501	430	357	282
63	207	175	142	107	518	449	377	303	
71	195	165	135	102	476	413	347	281	
153	25	155	88.3	13.9	-	772	643	505	359
	28	181	116	47.2	-	768	642	511	374
	31.5	196	138	75.4	6.3	730	614	495	369
	35.5	202	147	86.3	19.8	711	599	483	364
	40	206	154	98.2	36.5	678	573	466	353
	45	197	151	101	44.0	627	531	432	330
	50	252	208	162	114	667	575	478	378
	56	239	200	157	113	614	529	443	352
63	234	196	155	113	590	509	425	339	
71	224	189	151	111	556	480	402	321	
163	25	129	49.9	-	-	828	681	524	361
	28	175	108	31.8	-	804	670	529	383
	31.5	199	134	61.2	-	797	667	534	394
	35.5	213	154	88.8	16.7	758	639	514	386
	40	217	161	99.5	31.6	736	621	504	379
	45	219	167	111	47.6	701	595	483	369
	50	210	162	112	53.6	649	551	449	344
	56	264	219	172	121	689	594	495	393
63	251	208	166	120	633	547	457	364	
71	244	205	163	119	607	525	439	351	
173	25	38.6	-	-	-	948	767	577	379
	28	91.7	-	-	-	958	785	602	413
	31.5	144	65.4	-	-	926	766	603	430
	35.5	162	89.5	-	-	903	752	597	431
	40	183	113	37.8	-	871	728	582	428
	45	186	122	53.2	-	813	681	547	407
	50	286	230	170	105	885	760	629	494
	56	276	224	170	112	818	704	585	462
63	273	224	173	118	789	678	565	448	
71	267	220	172	120	747	644	536	426	
183	25	-	-	-	-	962	764	557	336
	28	73.0	-	-	-	976	795	605	405
	31.5	124	34.0	-	-	982	811	626	436
	35.5	170	92.8	-	-	950	788	623	449
	40	187</							

TR

NOMİNAL ÇIKIŞ MOMENTİ

EN

NOMINAL OUTPUT TORQUES

DE

NENN-ABTRIEBSDREHMOMENTE

Tip / Types / Bauarten PB...3-H									
Tahvil oranı i_N , Nominal çıkış momenti T_{2N} . Transmission ratios i_N , nominal output torques T_{2N} Übersetzungen i_N , Nenn-Abtriebsdrehmomente T_{2N}									
i_N	Redüktör Boyutları / Gear unit sizes / Getriebegrößen								
	43	53	63	73	83	93	103	113	123
Nominal çıkış momenti T_{2N} kNm / Nominal output torques T_{2N} in kNm / Abtriebsdrehmomente T_{2N} in kNm									
25	6.8	11.8	15.8	22.1	27.7	36.4	44.7	64.8	78.7
28	6.8	11.8	15.8	22.1	27.7	36.4	44.7	64.8	78.7
31.5	6.8	11.8	15.8	22.1	27.7	36.4	44.7	64.8	78.7
35.5	6.8	11.8	15.8	22.1	27.7	36.4	44.7	64.8	78.7
40	6.8	11.8	15.8	22.1	27.7	36.4	44.7	64.8	78.7
45	6.8	11.8	15.8	22.1	27.7	36.4	44.7	64.8	78.7
50	6.8	11.8	15.8	22.1	27.7	36.4	44.7	64.8	78.7
56	6.8	11.8	15.8	22.1	27.7	36.4	44.7	64.8	78.7
63	6.7	11.6	15.8	21.8	27.7	36.4	44.7	64.8	78.7
71	6.7	11.2	15.8	20.4	27.7	34.7	44.7	61.2	78.7

Tip / Types / Bauarten PB...3-H						
Tahvil oranı i_N , Nominal çıkış momenti T_{2N} . Transmission ratios i_N , nominal output torques T_{2N} Übersetzungen i_N , Nenn-Abtriebsdrehmomente T_{2N}						
i_N	Redüktör Boyutları / Gear unit sizes / Getriebegrößen					
	133	143	153	163	173	183
Nominal çıkış momenti T_{2N} kNm / Nominal output torques T_{2N} in kNm / Abtriebsdrehmomente T_{2N} in kNm						
25	92.5	115	156	176	204	245
28	92.5	115	156	176	204	245
31.5	92.5	115	156	176	204	245
35.5	92.5	115	156	176	204	245
40	92.5	115	156	176	204	245
45	92.5	115	156	176	204	245
50	92.5	115	156	176	204	245
56	92.5	115	156	176	204	245
63	92.5	115	156	176	204	245
71	92.5	115	156	176	204	245

TR NOMİNAL ÇIKIŞ MOMENTİ

Redüktörün uygulama alanına göre her gövde için iki farklı yardımcı redüktör seçilebilir:

1) Arıza-Bakım Çalışması

Yardımcı redüktörün motor dönme yönü ile boş kovalı elevatörün düşük hızlı dönüş yönü aynıdır.

2) Yük altında çalışma

Yardımcı redüktörün motor dönme yönü, dolu kovalarla düşük devirde kısa süreliğine aynı yönde dönecek şekilde çalıştırılabilir. Yardımcı redüktör ana redüktörün nominal çıkış momentini kapsamaz. Lütfen T₃ değerine dikkat ediniz.

Yardımcı redüktör tasarımı

Yardımcı redüktör ana redüktöre motor bağlantı adaptörü ile montajı yapılmıştır. Yardımcı redüktör olarak PKD (helisel-konik dişli) TMG-B5 veya TMG-B14 versiyonları ana redüktöre serbest kavrama ile akuple edilmiştir. Kavrama, bağlantı adaptörü içerisinde yer almaktadır ve bu adaptör yağ ile doldurulmuştur. Yardımcı redüktörün bağlantısında kullanılan kavramanın fonksiyon bozukluklarında meydana gelebilecek hız artışlarını engellemek için müşteri hız göstergesi kullanarak sistemi koruma altına alınmalıdır (sayfa 253'e bakınız). Ana redüktörün 4 ila 12 gövde büyüklüğüne kadar kullanılan yardımcı redüktörler yumuşak kalkışı desteklemek için yüksek ataletli fan ile verilir.

EN NOMİNAL OUTPUT TORQUES

Dependent on the case of application, for each gear unit size two different auxiliary drives are available:

1) Maintenance drive

The motor of the auxiliary drive is dimensioned in such a way that the bucket elevator can be operated with empty buckets at low speed in the same direction of rotation.

2) Operation under load

The motor of the auxiliary drive is dimensioned in such a way that the bucket elevator can be operated with full buckets for a short time at low speed in the same direction of rotation. The auxiliary drive is not designed for the nominal output torque of the main drive, please note T₃.

Design of auxiliary drives

The auxiliary drive is flanged to the main gear unit by means of an intermediate flange. The auxiliary drive is a PKD bevel-helical geared motor type TMG-B5 or TMG-B14 which is coupled to the main gear unit via an overrunning clutch. The overrunning clutch is located in the intermediate flange and supplied with oil from the main gear unit. The PKD bevel-helical geared motor has an own oil filling and is supplied filled with oil. To prevent overspeeds in the case of malfunctions of the overrunning clutch, the customer has to provide a speed monitor for the protection of the drive combination, see page 253.

The auxiliary drives for operation under load, for main gear unit sizes 4 to 12, have a high inertia fan for supporting smooth starting.

DE NENN-ABTRIEBSDREHMOMENTE

Je nach Einsatzfall stehen für jede Getriebegröße zwei unterschiedlich starke Hilfsantriebe zur Wahl:

1) Wartungsantrieb

Der Motor des Hilfsantriebes ist so dimensioniert, dass das Becherwerk mit leeren Bechern bei niedriger Drehzahl in gleicher Drehrichtung betrieben werden kann.

2) Lastbetrieb

Der Motor des Hilfsantriebes ist so dimensioniert, dass das Becherwerk mit vollen Bechern bei niedriger Drehzahl in gleicher Drehrichtung kurzzeitig betrieben werden kann. Der Hilfsantrieb ist nicht für das Nenn-Abtriebsdrehmoment des Hauptantriebes ausgelegt, bitte T₃ beachten.

Ausführung des Hilfsantriebes

Der Hilfsantrieb ist über einen Zwischenflansch an das Hauptgetriebe angeflanscht. Beim Hilfsantrieb handelt es sich um einen PKD Kegelstrinradtriebemotor Bauart TMG-B5 oder TMG-B14, der über eine Überholkupplung an das Hauptgetriebe angekuppelt ist. Die Überholkupplung ist im Zwischenflansch untergebracht und wird mit Öl befüllt geliefert. Zur Vermeidung von Überdrehzahlen bei Funktionsstörungen aus Überholkupplung ist die Antriebskombination aus Sicherheitsgründen kundenseitig mit einem Drehzahlwächter auszurüsten, siehe Seite 253. Die Hilfsantriebe für Lastbetrieb der Hauptgetriebegrößen 4 bis 12 erhalten zur Unterstützung des Sanftanlaufes einen Schwungmassenlüfter.

Ana redüktör Main gear unit Hauptgetriebe Boyut Size Größe	Arıza-Bakım Çalışması / Maintenance drive / Wartungsantrieb								Yük altında çalışma / Operation under load / Lastbetrieb							
	1) n ₃ [min ⁻¹]	1) T ₃ [kNm]	2) Motorlu redüktör Geared motor Getriebemotor	P _M [kW]	3) T _{MA} T _M	4) I [A]	i	Çıkış shaft Output shaft Abtriebswelle Ødxl [mm]	1) n ₃ [min ⁻¹]	1) T ₃ [kNm]	2) Motorlu redüktör Geared motor Getriebemotor	P _M [kW]	3) T _{MA} T _M	4) I [A]	i	Çıkış shaft Output shaft Abtriebswelle Ødxl [mm]
43	2.5	2.7	PKD 1390 80M/4B	0.75	2.5	2.1	34.86	40x80	2.6	4.0	PKD 1390 90S/4A	1.1	2.5	2.7	34.86	40x80
53	2.5	5.1	PKD 1390 90L/4A	1.5	2.5	3.6	34.86	40x80	3.2	6.5	PKD 2390 100L/4A	2.2	2.7	5.1	29.22	50x100
63	2.0	6.3	PKD 1390 90L/4A	1.5	2.5	3.6	34.86	40x80	2.5	8.1	PKD 2390 100L/4A	2.2	2.7	5.1	29.22	50x100
73	2.8	7.0	PKD 2390 100L/4A	2.2	2.7	5.1	31.43	50x100	3.1	11.9	PKD 3390 112M/4B	4	2.7	8.7	29.67	70x140
83	2.2	8.7	PKD 2390 100L/4A	2.2	2.7	5.1	31.43	50x100	2.5	15.0	PKD 3390 112M/4B	4	2.7	8.7	29.67	70x140
93	2.8	9.5	PKD 2390 100L/4B	3	2.7	6.8	31.43	50x100	2.5	20.0	PKD 3390 132S/4C	5.5	2.7	11.3	35.65	70x140
103	2.2	11.9	PKD 2390 100L/4B	3	2.7	6.8	40.37	50x100	2.0	25.0	PKD 3390 132S/4C	5.5	2.7	11.3	35.65	70x140
113	2.1	12.4	PKD 3390 100L/4B	3	2.7	6.8	40.37	70x140	2.5	34.8	PKD 4390 132M/4	9.2	2.7	18.9	34.38	80x170
123	1.65	15.4	PKD 3390 100L/4B	3	2.7	6.8	40.37	70x140	1.9	44.0	PKD 4390 132M/4	9.2	2.7	18.9	34.38	80x170
133	2.1	16.6	PKD 3390 112M/4B	4	2.7	8.7	40.37	70x140	3.3	51.7	PKD 5390 180M/4B	18.5	2.3	36.8	27.37	90x170
143	1.65	20.6	PKD 3390 112M/4B	4	2.7	8.7	40.37	70x140	2.7	64.2	PKD 5390 180M/4B	18.5	2.3	36.8	27.37	90x170
153	2.1	16.6	PKD 3390 112M/4B	4	2.7	8.7	40.37	70x140	3.3	85.5	PKD 8390 200L/4C	30	2.6	56	26.79	120x210
163	1.8	18.6	PKD 3390 112M/4B	4	2.7	8.7	40.37	70x140	1.9	97.0	PKD 8390 200L/4C	30	2.6	56	26.79	120x210
173	2.1	16.6	PKD 3390 112M/4B	4	2.7	8.7	40.37	70x140	3.2	101.1	PKD 8390 225S/4A	37	2.4	70	26.79	120x210
183	1.8	18.6	PKD 3390 112M/4B	4	2.7	8.7	40.37	70x140	2.9	117.2	PKD 8390 225S/4A	37	2.4	70	26.79	120x210

Redüktör tasarımı / Design of gear units / Ausführung der Getriebe

PGR : Helisel Konik Tasarım / Design / Ausführung D
PKD : Tasarım / Design / Ausführung A/2A
Montaj pozisyonu / Mounting position / Einbaulage B5-02

PGR: Tasarım / Design / Ausführung B
PKD: Tasarım / Design / Ausführung A/2A
Montaj pozisyonu / Mounting position / Einbaulage B5-02

- 1) Ana redüktörün yardımcı redüktöre bağlandığı yerdeki giriş hızı (50Hz, n₁=1500d/d; 60 Hz de n₃ % ≈20 artar).
- 2) PKD helisel konik dişli redüktör
- 3) Direk çalışma durumunda motorun başlama torku T_{MA} ile yardımcı redüktör motorunun nominal torku T_M.
- 4) Anma akımı 400 V dur.

- 1) On main gear unit output shaft in case of input via auxiliary drive (50Hz, n₁ = 1500min⁻¹ ; at 60 Hz n₃ will be ≈20 % higher).
- 2) PKD bevel-helical geared motor
- 3) In case direct switching on, motor starting torque T_{MA} as a multiple of the nominal motor torque T_M of the auxiliary drive.
- 4) Rated current at 400 V.

- 1) An Abtriebswelle des Hauptgetriebes bei Antrieb über Hilfsantrieb (50 Hz, n₁ = 1500 min⁻¹ ; bei 60Hz wird n₃ ≈20 % höher).
- 2) PKD Kegelstrinradtriebemotor
- 3) Motor-Anzugsdrehmoment T_{MA} beim direkten Einschalten als Vielfaches des Motor -Nenn Drehmomentes T_M des Hilfsantriebes.
- 4) Bemessungsstrom bei 400 V.

TR ÜÇ KADEMELİ YARDIMCI REDÜKTÖR
(Yük Altında Çalışma)

EN THREE STAGE WITH AUXILIARY DRIVE
(Operation Under Load)

DE DREISTUFIG MIT HILFSANTRIEB
(Lastbetrieb)

PB...3-SH PB...3-HH PB...3-DH

Ana redüktör / Main gear unit / Hauptgetriebe:

PGR dişli ünitesi
PGR gear unit
PGR-Zahnradgetriebe

Operation under load

Yağ / Oil / Öl :
PGLP ISO VG 320

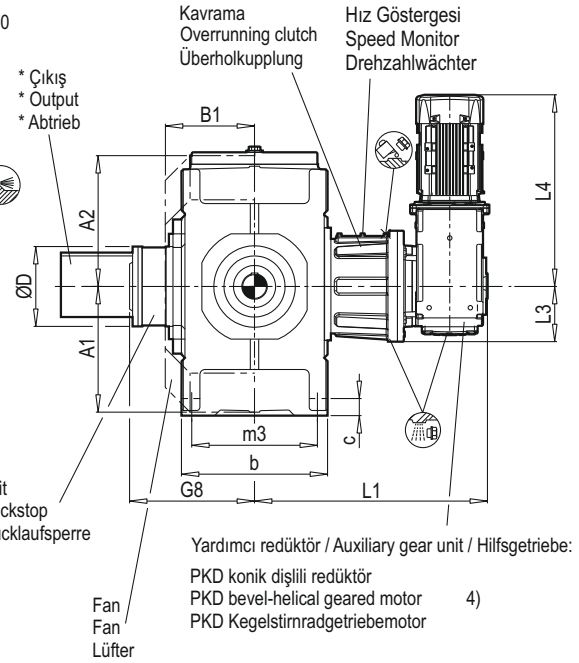
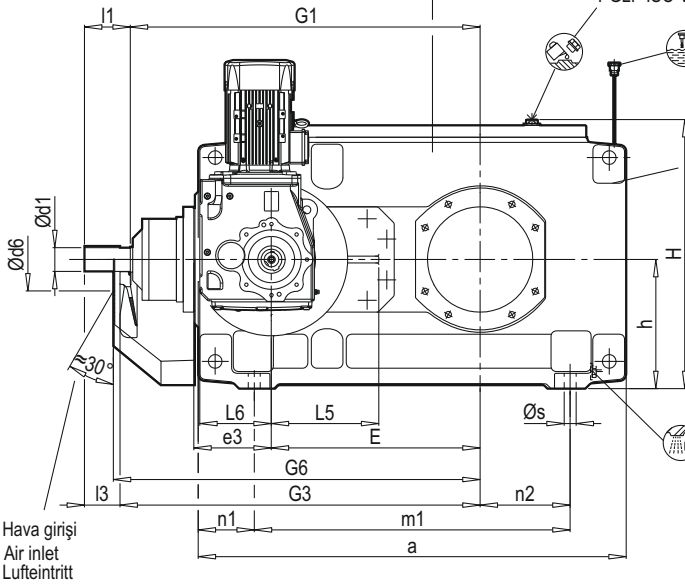

PB...3-H: Dizayn / Design / Ausführung D
PKD: Dizayn / Design / Ausführung A/2A⁶⁾
Montaj pozisyonu / Mounting position / Einbaulage **B5-02**

PB...3-H: Dizayn / Design / Ausführung B
PKD: Dizayn / Design / Ausführung B/2A⁶⁾
Montaj pozisyonu / Mounting position / Einbaulage **B5-02**

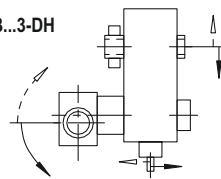
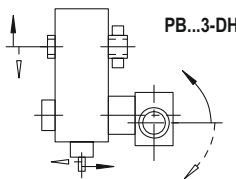
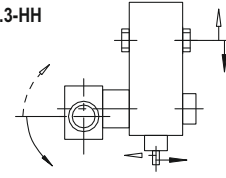
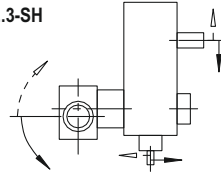
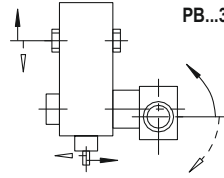
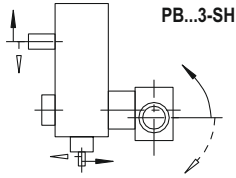

Çıkış / Output / Abtrieb

PB...3-SH
Mil çıkışı / Solid shaft / Vollwelle

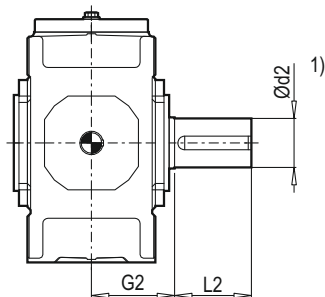

PB...3-HH
Delik milli / Hollow shaft / Hohlwelle

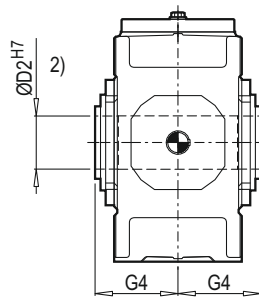

PB...3-DH
Delik milli, konik sıkırtmalı
Hollow shaft for shrink disk
Hohlwelle für Schrumpfscheibe

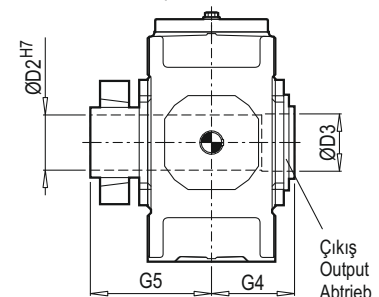

1) $k6 \leq \text{Ø}25$ $\text{Ø}28 \geq m_6 \leq \text{Ø}100$ $n_6 > \text{Ø}100$

Kamalar DIN 6885/1'e göre form B merkez kılavuz delikleri için sayfa 244'e bakınız / For parallel key DIN 6885/1 form B and for centre hole, see page 244.
Passfeder DIN 6885/1 Form B und Zentrierung siehe Seite 244.

2) Kama kanalları DIN 6885/1'e göre / Passfedermut DIN 6885/1 / Keyway DIN 6885/1

TR ÜÇ KADEMELİ YARDIMCI REDÜKTÖR
(Yük Altında Çalışma)

EN THREE STAGE WITH AUXILIARY DRIVE
(Operation Under Load)

DE DREISTUFIG MIT HILFSANTRIEB
(Lastbetrieb)

Ana Redüktör Main gear unit Hauptgetriebe	Yardımcı redüktör Auxiliary gear unit Hilfsgetriebe	Ölçüler mm / Dimensions in mm / Maße in mm													G ₁	G ₃	
		Giriş / Input / Antrieb															
		i _N = 25 - 45			i _N = 25 - 56			i _N = 50 - 71			i _N = 63 - 71						
		Ød ₁ ¹⁾	l ₁	l ₃	Ød ₁ ¹⁾	l ₁	l ₃	Ød ₁ ¹⁾	l ₁	l ₃	Ød ₁ ¹⁾	l ₁	l ₃				
43	PKD 1390 80M/4B	30	70	50				25	60	40						500	520
53	PKD 1390 90L/4A	35	80	60				28	60	40						575	595
63	PKD 1390 90L/4A				35	80	60				28	60	40			610	630
73	PKD 2390 100L/4A	45	100	80				35	80	60						690	710
83	PKD 2390 100L/4A				45	100	80				35	80	60			735	755
93	PKD 2390 100L/4A	55	110	80				40	100	70						800	830
103	PKD 2390 100L/4A				55	110	80				40	100	70			850	880
113	PKD 3390 100L/4B	70	135	105				50	110	80						960	990
123	PKD 3390 100L/4B				70	135	105				50	110	80			1030	1060

Boyut Size Größe	Ölçüler mm / Dimensions in mm / Maße in mm																							
	Redüktör / Gear units / Zahnradgetriebe																							
	a	A ₁	A ₂	b	B ₁	c	Ød ₆	e ₃	E	G ₆	G ₈	h	H	m ₁	m ₃	n ₁	n ₂	Øs	L ₁	L ₃	L ₄	L ₅	L ₆	ØD
43	569	197	202	217	145	30	110	110	270	530	204	200	420	355	180	107	85	19	480	125	435	145	112	129
53	644	222	237	257	170	30	130	130	315	605	223	230	487	430	220	107	100	19	485	125	478	175	112	154
63	724	222	237	257	170	30	130	130	350	640	223	230	487	510	220	107	145	19	485	125	478	175	112	154
73	789	277	277	302	195	37	165	160	385	720	281	280	577	545	260	122	130	24	587	150	529	220	143	179
83	894	277	277	302	195	37	165	160	430	765	281	280	587	650	260	122	190	24	587	150	529	220	143	179
93	929	317	327	372	233	42	175	185	450	845	317	320	667	635	320	147	155	28	667	175	529	265	143	194
103	1029	317	327	372	233	42	175	185	500	895	317	320	667	735	320	147	205	28	667	175	529	265	143	194
113	1109	372	387	432	265	52	190	225	545	1010	368	380	787	775	370	167	180	35	765	225	541	325	180	237
123	1264	372	387	432	265	52	190	225	615	1080	368	380	795	930	370	167	265	35	765	225	541	325	180	237

Boyut Size Größe	Ölçüler mm / Dimensions in mm / Maße in mm									Yağ / Oil / Öl		Ağırlık / Weight Gewicht	
	Çıkış / Output / Abtrieb									TMGB14-B5 ⁴⁾	PB...3-H ³⁾	TMGB14-B5 ⁴⁾	PB...3-H ³⁾
	PB...3-SH			PB...3-HH		PB...3-DH							
	Ød ₂ ¹⁾	G ₂	l ₂	ØD ₂ ²⁾	G ₄	ØD ₂	ØD ₃	G ₄	G ₅	(l)	(l)	(kg)	(kg)
43	80	140	170	80	140	85	85	140	205	2.5	10	43	245
53	100	165	210	95	165	100	100	165	240	2.5	16	45	360
63	110	165	210	105	165	110	110	165	240	2.5	17	45	410
73	120	195	210	115	195	120	120	195	280	4.3	30	64	620
83	130	195	250	125	195	130	130	195	285	4.3	33	64	700
93	140	235	250	135	235	140	145	235	330	4.3	45	64	980
103	160	235	300	150	235	150	155	235	350	4.3	48	64	1220
113	170	270	300	165	270	165	170	270	400	7.4	79	89	1615
123	180	270	300	180	270	180	185	270	405	7.4	84	89	1890

3) Diğer bilgilere ve ölçülere PKD kataloğundan ulaşabilirsiniz.

4) Diğer ölçüler ve bilgiler için gerekli kataloglara bakınız.

6) B/2A tasarım mümkündür.

3) Other data and dimensions acc. to PKD catalog.

4) Other data and dimensions acc.

6) Design B/2A is possible.

3) Sonst. Daten und Abmessungen nach Katalog

4) Sonst. Daten und Abmessungen nach Katalog

6) Ausführung B/2A ist möglich.

TR ÜÇ KADEMELİ YARDIMCI REDÜKTÖR
(Yük Altında Çalışma)

EN THREE STAGE WITH AUXILIARY DRIVE
(Operation Under Load)

DE DREISTUFIG MIT HILFSANTRIEB
(Lastbetrieb)

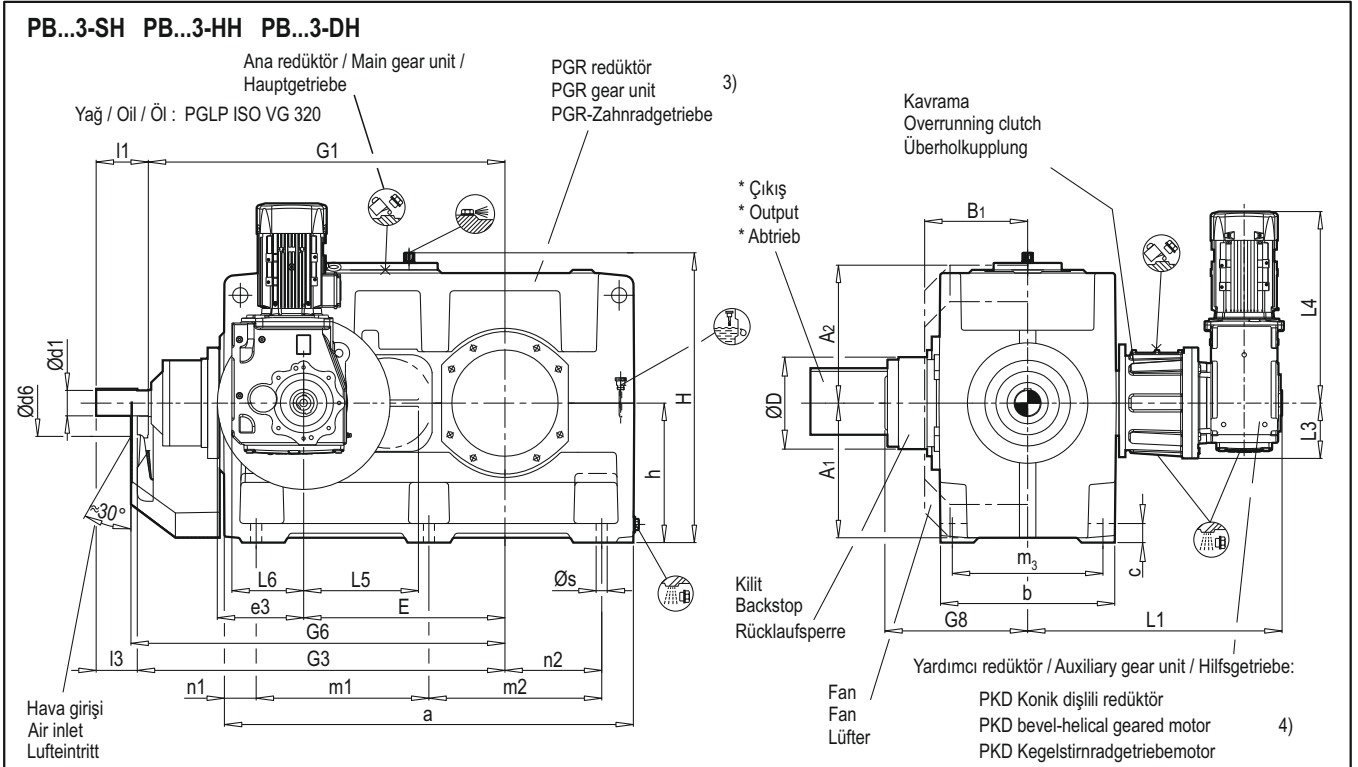

PB...3-H: Dizayn / Design / Ausführung D
PKD: Dizayn / Design / Ausführung A/2A⁶⁾
Montaj pozisyonu / Mounting position / Einbaulage B5-02

PB...3-H: Dizayn / Design / Ausführung B
PKD: Dizayn / Design / Ausführung B/2A⁶⁾
Montaj pozisyonu / Mounting position / Einbaulage B5-02

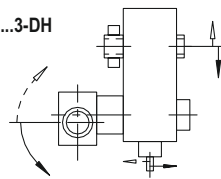
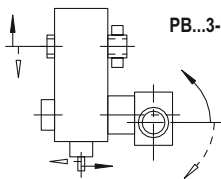
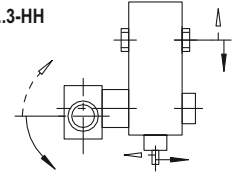
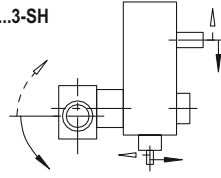
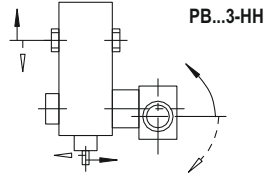
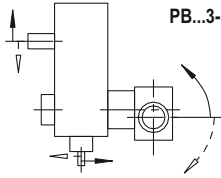

Çıkış / Output / Abtrieb

PB...3-SH
Mil çıkışlı / Solid shaft
Vollwelle

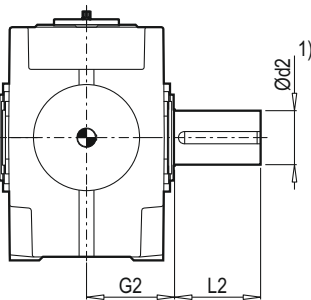

PB...3-HH
Delik milli / Hollow shaft
Hohlwelle

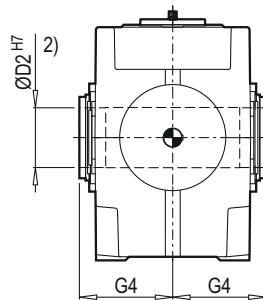

PB...3-DH
Delik milli, konik sıkırtmalı
Hollow shaft for shrink disk
Hohlwelle für Schrumpfscheibe

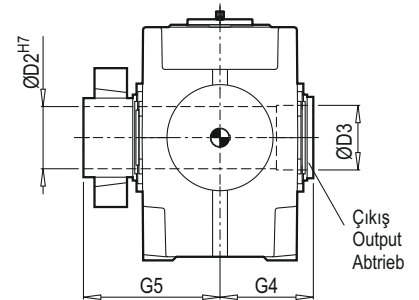

1) $m_6 \leq \varnothing 100$ $n_6 > \varnothing 100$

Kamalar DIN 6885/1'e göre form B merkez klavuz delikleri için sayfa 244'ye bakınız / For parallel key DIN 6885/1 form B and for centre hole, see page 244
Passfedern DIN 6885/1 Form B und Zentrierung siehe Seite 244

2) Kama kanalları DIN 6885/1'e göre / Passfedernut DIN 6885/1 / Keyway DIN 6885/1

TR ÜÇ KADEMELİ YARDIMCI REDÜKTÖR
(Yük Altında Çalışma)

EN THREE STAGE WITH AUXILIARY DRIVE
(Operation Under Load)

DE DREISTUFIG MIT HILFSANTRIEB
(Lastbetrieb)

Ana Redüktör Main gear unit Hauptgetriebe	Yardımcı redüktör Auxiliary gear unit Hilfsgetriebe	Ölçüler mm / Dimensions in mm / Maße in mm																					
		Giriş / Input / Antrieb																					
		i _N = 25 - 45			i _N = 25 - 50			i _N = 25 - 56			i _N = 50 - 71			i _N = 56 - 71			i _N = 63 - 71			G ₁	G ₃		
Ød ₁ ¹⁾	l ₁	l ₃	Ød ₁ ¹⁾	l ₁	l ₃	Ød ₁ ¹⁾	l ₁	l ₃	Ød ₁ ¹⁾	l ₁	l ₃	Ød ₁ ¹⁾	l ₁	l ₃	Ød ₁ ¹⁾	l ₁	l ₃						
133	PKD 3390 112M/4B	80	165	130						60	140	105								1125	1160		
143	PKD 3390 112M/4B							80	165	130									60	140	105	1195	1230
153	PKD 3390 112M/4B	90	165	130						70	140	105										1367	1402
163	PKD 3390 112M/4B				90	165	130							70	140	105						1413	1448
173	PKD 3390 112M/4B	110	205	165						80	170	130										1560	1600
183	PKD 3390 112M/4B				110	205	165							80	170	130						1620	1660

Boyut Size Größe	Ölçüler mm / Dimensions in mm / Maße in mm																								
	Redüktör / Gear units / Zahnradgetriebe																								
	a	A ₁	A ₂	b	B ₁	c	Ød ₆	e ₃	E	G ₆	G ₈	h	H	m ₁	m ₂	m ₃	n ₁	n ₂	Øs	L ₁	L ₃	L ₄	L ₅	L ₆	ØD
133	1294	427	437	552	327	62	210	265	635	1180	451	440	905	545	545	475	102	305	35	815	273	586	367	180	291
143	1434	427	437	552	327	62	210	265	705	1250	451	440	905	545	685	475	102	375	35	815	273	586	367	180	291
153	1554	487	522	627	367	72	210	320	762	1420	497	500	1005	655	655	535	122	365	42	865	300	586	448	180	323
163	1644	487	522	627	367	72	210	320	808	1470	497	500	1005	655	745	535	122	410	42	865	300	586	448	180	323
173	1744	537	572	572	397	82	230	370	860	1620	564	550	1115	735	735	600	137	390	42	905	333	586	525	180	413
183	1864	537	572	572	397	82	230	370	920	1680	564	550	1115	735	855	600	137	450	42	905	333	586	525	180	413

Boyut Size Größe	Ölçüler mm / Dimensions in mm / Maße in mm										Yağ / Oil / Öl		Ağırlık / Weight Gewicht	
	Çıkış / Output / Abtrieb										TMGB14-B5 ⁴⁾	PB...3-H ³⁾	TMGB14-B5 ⁴⁾	PB...3-H ³⁾
	PB...3-SH			PB...3-HH		PB...3-DH								
	Ød ₂ ¹⁾	G ₂	l ₂	ØD ₂ ²⁾	G ₄	ØD ₂	ØD ₃	G ₄	G ₅		(l)	(l)	(kg)	(kg)
133	200	335	350	190	335	190	195	335	480		7.4	145	96	2595
143	210	335	350	210	335	210	215	335	480		7.4	155	96	2945
153	230	380	410	230	380	230	235	380	550		7.4	230	96	4010
163	240	380	410	240	380	240	245	380	550		7.4	240	96	4275
173	250	415	410	250	415	250	260	415	600		7.4	315	96	5485
183	270	415	410	275	415	280	285	415	600		7.4	315	96	5940

3) Diğer bilgilere ve ölçülere PKD kataloğundan ulaşabilirsiniz.

3) Other data and dimensions acc. to PKD catalog page...

3) Sonst. Daten und Abmessungen nach Katalog

4) Diğer ölçüler ve bilgiler için gerekli kataloğlara bakınız.

4) Other data and dimensions acc. to page..

4) Sonst. Daten und Abmessungen nach Katalog

6) B/2A tasarım mümkündür.

6) Design B/2A is possible.

6) Ausführung B/2A ist möglich.

TR ÜÇ KADEMELİ YARDIMCI REDÜKTÖR
(Yük Altında Çalışma)

EN THREE STAGE WITH AUXILIARY DRIVE
(Operation Under Load)

DE DREISTUFIG MIT HILFSANTRIEB
(Lastbetrieb)

Ana redüktör Main gear unit Hauptgetriebe	Yardımcı redüktör Auxiliary gear unit Hilfsgetriebe	Ölçüler mm / Dimensions in mm / Maße in mm													
		Giriş / Input / Antrieb													
		i _N = 25 - 45			i _N = 25 - 56			i _N = 50 - 71			i _N = 63 - 71			G ₁	G ₃
		Ød ₁ ¹⁾	l ₁	l ₃	Ød ₁ ¹⁾	l ₁	l ₃	Ød ₁ ¹⁾	l ₁	l ₃	Ød ₁ ¹⁾	l ₁	l ₃		
43	PKD 1390 90S/4A	30	70	50				25	60	40				500	520
53	PKD 2390 100L/4A	35	80	60				28	60	40				575	595
63	PKD 2390 100L/4A				35	80	60				28	60	40	610	630
73	PKD 3390 112M/4B	45	100	80				35	80	60				690	710
83	PKD 3390 112M/4B				45	100	80				35	80	60	735	755
93	PKD 3390 132S/4C	55	110	80				40	100	70				800	830
103	PKD 3390 132S/4C				55	110	80				40	100	70	850	880
113	PKD 4390 132M/4	70	135	105				50	110	80				960	990
123	PKD 4390 132M/4				70	135	105				50	110	80	1030	1060

Boyut Size Größe	Ölçüler mm / Dimensions in mm / Maße in mm																							
	Redüktör / Gear units / Zahnradgetriebe																							
	a	A ₁	A ₂	b	B ₁	c	Ød ₆	e ₃	E	G ₆	G ₈	h	H	m ₁	m ₃	n ₁	n ₂	Øs	L ₁	L ₃	L ₄	L ₅	L ₆	ØD
43	569	197	202	217	145	30	110	110	270	530	204	200	420	355	180	107	85	19	483	125	478	142	112	129
53	644	222	237	257	170	30	130	130	315	605	223	230	487	430	220	107	100	19	513	125	529	170	143	154
63	724	222	237	257	170	30	130	130	350	640	223	230	487	510	220	107	145	19	513	125	629	170	143	154
73	789	277	277	302	195	37	165	160	385	720	281	280	577	545	260	122	130	24	636	150	586	215	180	179
83	894	277	277	302	195	37	165	160	430	765	281	280	587	650	260	122	190	24	636	150	586	215	180	179
93	929	317	327	372	233	42	175	185	450	845	317	320	667	635	320	147	155	28	718	175	593	260	180	194
103	1029	317	327	372	233	42	175	185	500	895	317	320	667	735	320	147	205	28	718	175	593	260	180	194
113	1109	372	387	432	265	52	190	225	545	1010	368	380	787	775	370	167	180	35	802	225	648	320	217	237
123	1264	372	387	432	265	52	190	225	615	1080	368	380	795	930	370	167	265	35	802	225	648	320	217	237

Boyut Size Größe	Ölçüler mm / Dimensions in mm / Maße in mm										Yağ / Oil / Öl		Ağırlık / Weight Gewicht	
	Çıkış / Output / Abtrieb													
	PB...3-SH			PB...3-HH		PB...3-DH					TMGB14-B5 ⁴⁾	PB...3-H ³⁾	TMGB14-B5 ⁴⁾	PB...3-H ³⁾
	Ød ₂ ¹⁾	G ₂	l ₂	ØD ₂ ²⁾	G ₄	ØD ₂	ØD ₃	G ₄	G ₅		(l)	(l)	(kg)	(kg)
43	80	140	170	80	140	85	85	140	205		2	10	45	245
53	100	165	210	95	165	100	100	165	240		2.65	16	64	360
63	110	165	210	105	165	110	110	165	240		2.65	17	64	410
73	120	195	210	115	195	120	120	195	280		7.4	30	96	620
83	130	195	250	125	195	130	130	195	285		7.4	33	96	700
93	140	235	250	135	235	140	145	235	330		7.4	45	112	980
103	160	235	300	150	235	150	155	235	350		7.4	48	112	1220
113	170	270	300	165	270	165	170	270	400		11.6	79	171	1615
123	180	270	300	180	270	180	185	270	405		11.6	84	171	1890

3) Diğer bilgiler ve ölçülere PKD kataloğundan ulaşabilirsiniz.

3) Other data and dimensions acc. to PKD catalog.

3) Sonst. Daten und Abmessungen nach Katalog.

4) Diğer ölçüler ve bilgiler için gerekli kataloglara bakınız.

4) Other data and dimensions acc. to page..

4) Sonst. Daten und Abmessungen nach Katalog

6) B/2A tasarım mümkündür.

6) Design B/2A is possible.

6) Ausführung B/2A ist möglich.

TR ÜÇ KADEMELİ YARDIMCI REDÜKTÖR
(Yük Altında Çalışma)

EN THREE STAGE WITH AUXILIARY DRIVE
(Operation Under Load)

DE DREISTUFIG MIT HILFSANTRIEB
(Lastbetrieb)

PB...3-SH PB...3-HH PB...3-DH

Ana redüktör / Main gear unit / Hauptgetriebe
Yağ / Oil / Öl: PGLP ISO VG 320

PGR-Redüktör
PGR gear unit
PGR-Zahnradgetriebe

Kavrama
Overrunning clutch
Überholkupplung

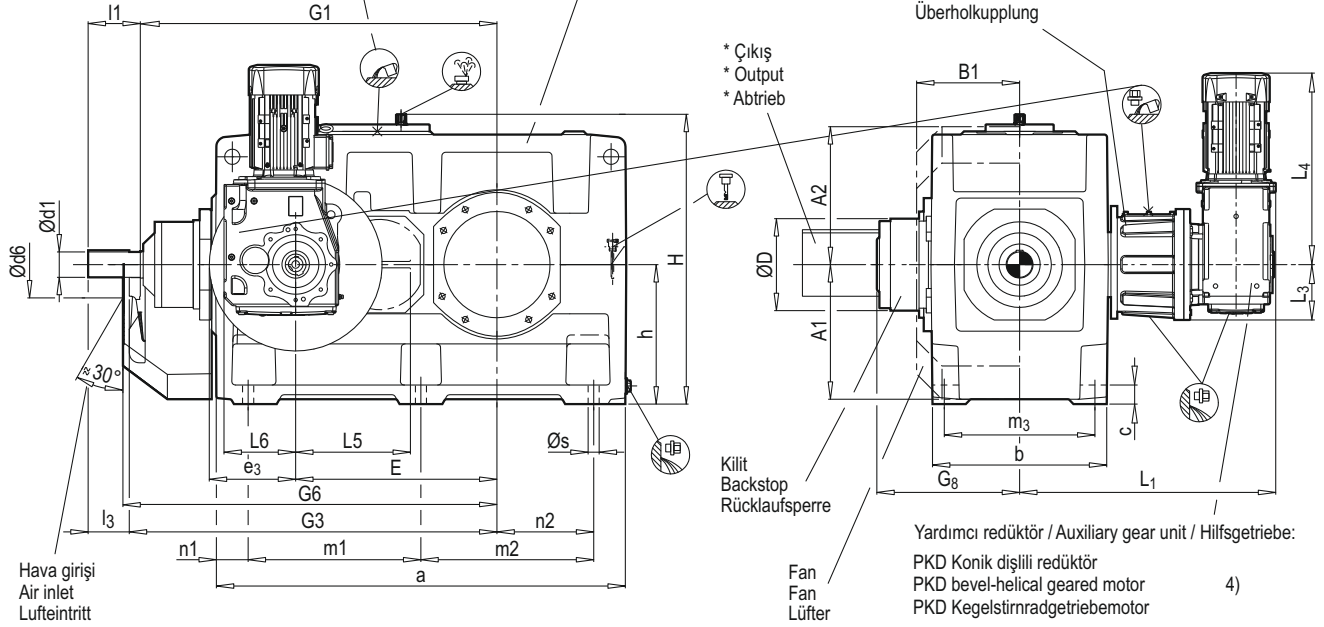

PB...3-H: Dizayn / Design / Ausführung D
PKD: Dizayn / Design / Ausführung A/2A⁶⁾
Montaj pozisyonu / Mounting position / Einbaulage B5-02

PB...3-H: Dizayn / Design / Ausführung B
PKD: Dizayn / Design / Ausführung B/2A⁶⁾
Montaj pozisyonu / Mounting position / Einbaulage B5-02

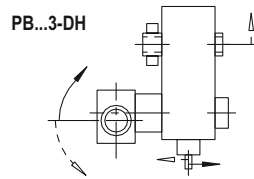
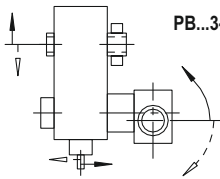
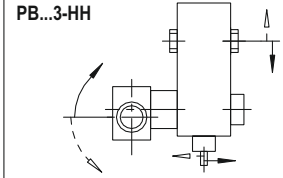
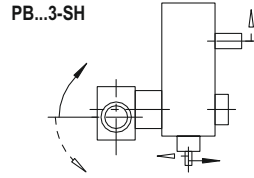
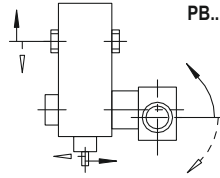
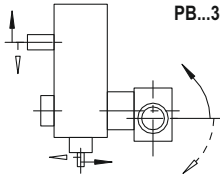

Çıkış / Output / Abtrieb

PB...3-SH
Mil çıkışlı / Solid shaft
Vollwelle

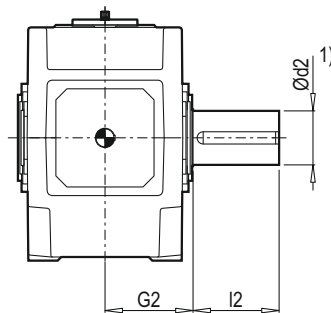

PB...3-HH
Delik millî / Hollow shaft
Hohlwelle

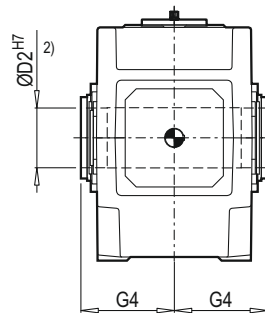

PB...3-DH
Delik millî konik sıkırtmalı
Hollow shaft for shrink disk
Hohlwelle für Schrumpfscheibe

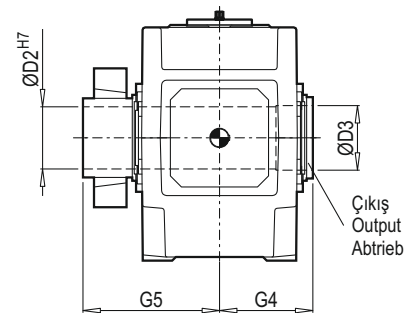

1) $m_6 \leq \varnothing 100$ $n_6 > \varnothing 100$

Kamalar DIN 6885/1'e göre form B merkez klavuz delikleri için sayfa 244'ye bakınız / For parallel key DIN 6885/1 form B and for centre hole, see page 244
Passfedern DIN 6885/1 Form B und Zentrierung siehe Seite 244

2) Kama kanalları DIN 6885/1'e göre / Passfedernut DIN 6885/1/Keyway DIN 6885/1

TR ÜÇ KADEMELİ YARDIMCI REDÜKTÖR
(Yük Altında Çalışma)

EN THREE STAGE WITH AUXILIARY DRIVE
(Operation Under Load)

DE DREISTUFIG MIT HILFSANTRIEB
(Lastbetrieb)

Ana redüktör Main gear unit Hauptgetriebe	Yardımcı redüktör Auxiliary gear unit Hilfsgetriebe	Ölçüler mm / Dimensions in mm / Maße in mm																					
		Giriş / Input / Antrieb																					
		i _N = 25 - 45			i _N = 25 - 50			i _N = 25 - 56			i _N = 50 - 71			i _N = 56 - 71			i _N = 63 - 71			G ₁	G ₃		
Ød ₁ ¹⁾	l ₁	l ₃	Ød ₁ ¹⁾	l ₁	l ₃	Ød ₁ ¹⁾	l ₁	l ₃	Ød ₁ ¹⁾	l ₁	l ₃	Ød ₁ ¹⁾	l ₁	l ₃	Ød ₁ ¹⁾	l ₁	l ₃						
133	PKD 5390 180M/4B	80	165	130						60	140	105								1125	1160		
143	PKD 5390 180M/4B								80	165	130								60	140	105	1195	1230
153	PKD 8390 200L/4C	90	165	130						70	140	105										1367	1402
163	PKD 8390 200L/4C				90	165	130							70	140	105						1413	1448
173	PKD 8390 225S/4A	110	205	165						80	170	130										1560	1600
183	PKD 8390 225S/4A				110	205	165							80	170	130						1620	1660

Boyut Size Größe	Ölçüler mm / Dimensions in mm / Maße in mm																								
	Redüktör / Gear units / Zahnradgetriebe																								
	a	A ₁	A ₂	b	B ₁	c	Ød ₆	e ₃	E	G ₆	G ₈	h	H	m ₁	m ₂	m ₃	n ₁	n ₂	Øs	L ₁	L ₃	L ₄	L ₅	L ₆	ØD
133	1294	427	437	552	327	62	210	265	635	1180	451	440	905	545	545	475	102	305	35	946	273	881	367	262	291
143	1434	427	437	552	327	62	210	265	705	1250	451	440	905	545	685	475	102	375	35	946	273	881	367	262	291
153	1554	487	522	627	367	72	210	320	762	1420	497	500	1005	655	655	535	122	365	42	1117	300	1120	448	375	323
163	1644	487	522	627	367	72	210	320	808	1470	497	500	1005	655	745	535	122	410	42	1117	300	1120	448	375	323
173	1744	537	572	692	397	82	230	370	860	1620	564	550	1115	735	735	600	137	390	42	1167	332	1202	518	375	413
183	1864	537	572	692	397	82	230	370	920	1680	564	550	1115	735	855	600	137	450	42	1167	332	1202	518	375	413

Boyut Size Größe	Ölçüler mm / Dimensions in mm / Maße in mm										Yağ / Oil / Öl		Ağırlık / Weight Gewicht	
	Çıkış / Output / Abtrieb										TMGB14-B5 ⁴⁾	PB...3-H ³⁾	TMGB14-B5 ⁴⁾	PB...3-H ³⁾
	PB...3-SH			PB...3-HH		PB...3-DH								
	Ød ₂ ¹⁾	G ₂	l ₂	ØD ₂ ²⁾	G ₄	ØD ₂	ØD ₃	G ₄	G ₅		(l)	(l)	(kg)	(kg)
133	200	335	350	190	335	190	195	335	480		23.6	145	322	2595
143	210	335	350	210	335	210	215	335	480		23.6	155	322	2945
153	230	380	410	230	380	230	235	380	550		80.5	230	792	4010
163	240	380	410	240	380	240	245	380	550		80.5	240	792	4275
173	250	415	410	250	415	250	260	415	600		80.5	315	847	5485
183	270	415	470	275	415	280	285	415	600		80.5	325	847	5940

3) Diğer bilgilere ve ölçülere PKD kataloğundan ulaşabilirsiniz.

3) Other data and dimensions acc. to PKD catalog.

3) Sonst. Daten und Abmessungen nach Katalog.

4) Diğer ölçüler ve bilgiler için gerekli kataloğlara bakınız.

4) Other data and dimensions acc. to page..

4) Sonst. Daten und Abmessungen nach Katalog

6) B/2A tasarım mümkündür.

6) Design B/2A is possible.

6) Ausführung B/2A ist möglich.

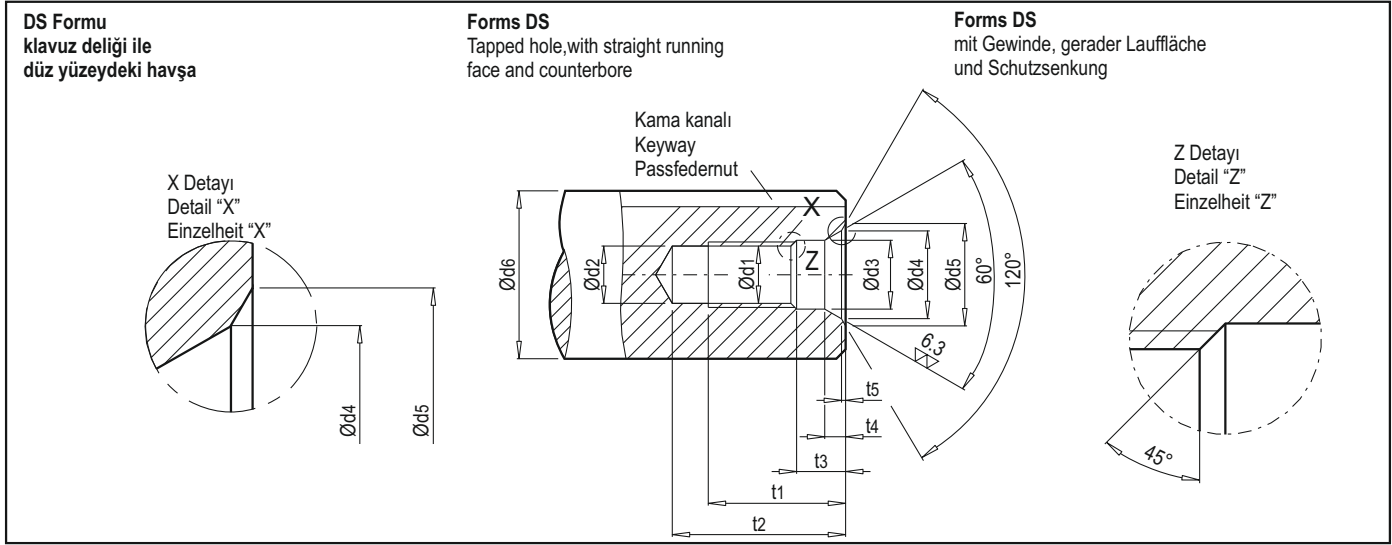

Önerilen çaplar Recommended diameters Empfohlene Durchmesserbereiche Ød6 ¹⁾		DS Formu / Form DS / Form DS												
Üstünde above über	kadar to bis	DS- Merkez Centering Zentrierung	Ød1	Ød2 2)	Ød3	Ød4	Ød5	t2		t3	t4	t5		
								+2	min. max.				+1	≈
		mm												
16	21	DS 6	M 6	5.0	6.4	9.6	10.5	16.0	21	23	5.0	2.8	0.4	
21	24	DS 8	M 8	6.8	8.4	12.2	13.2	19.0	25	28	6.0	3.3	0.4	
24	30	DS 10	M 10	8.5	10.5	14.9	16.3	22.0	30	34	7.5	3.8	0.6	
30	38	DS 12	M 12	10.2	13.0	18.1	19.8	28.0	37	42	9.5	4.4	0.7	
38	50	DS 16	M 16	14.0	17.0	23.0	25.3	36.0	45	50	12.0	5.2	1.0	
50	85	DS 20	M 20	17.5	21.0	28.4	31.3	42.0	53	59	15.0	6.4	1.3	
85	130	DS 24	M 24	21.0	25.0	34.2	38.0	50.0	63	68	18.0	8.0	1.6	
130	225	DS 30 *	M 30	26.5	31.0	40.2	44.6	60.0	77	83	17.0	8.0	1.9	
225	320	DS 36 *	M 36	32.0	37.0	49.7	55.0	74.0	93	99	22.0	11.0	2.3	
320	500	DS 42 *	M 42	37.5	43.0	60.3	66.6	84.0	105	111	26.0	15.0	2.7	

1) Bitmiş iş parçası çapı
2) DIN 336-1 e göre klavuzların matkap çapları

1) Diameter of the finished work piece
2) Drill diameters for tapping-size holes acc. to DIN 336 Pt.1

1) Durchmesser gilt für das fertige Werkstück
2) Kernloch- bohrerdurchmesser nach DIN 336 Teil1

*) Ölçüler DIN 332'ye göre değildir.

*) Dimensions not acc. to DIN 332

*) Abmessungen nicht nach DIN 332

Uygun ISO seçimi / Selection of ISO fits / Passungsauswahl				
Uygun ISO seçimi Selection of ISO fits Passungsauswahl	Şaft / Shaft / Welle Ød		Mil toleransı Shaft tolerance Wellentoleranz	Çap toleransı Bore tolerance Bohrungstoleranz
	üstünde above über mm	kadar to bis mm		
Mil toleransı v.b için PGR standart Shaft tolerance acc. to PGR Standard Wellentoleranz nach PGR Norm		25	k6	H7
	25	100	m6	
	100		n6	

Ağır çalışma koşullarında, yükün geri gelmesinden oluşan kesme kuvvetleri için kama sıkı geçme olmalıdır. ISO'ya göre P9 tavsiye edilir.

For heavy-duty operating conditions, e.g. reversing under load, it is recommended that a tighter fit and for the hub keyway width the ISO P9 tolerance is selected.

Für außergewöhnliche Betriebsverhältnisse, z.B. Reversierbetrieb unter Last, ist ein festerer Sitz und für die Nabennutbreite das ISO - Toleranzfeld P9 vorzusehen.

Bu durumda, müşteri ilgili bilgileri vermelidir.

In this case, the customer should give the relevant information.

Seitens des Kunden sind hierzu entsprechende Vorgaben notwendig.

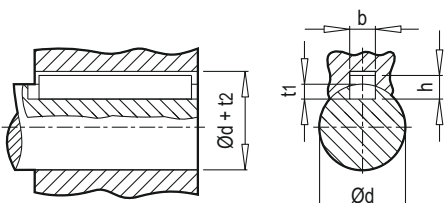
Paralel kamalar / Parallel keys / Passfedern						
Kama ve kama kanalı DIN 6885/1'e göre Parallel key and keyway acc. to DIN 6885/1 Passfeder und Nut nach DIN 6885/1	Çap Diameter Durchmesser Ød		Genişlik Width Breite b 1)	Yükseklik Height Höhe h	Şafttaki kama kanalı derinliği Depth of key- way in shaft Wellennuttiefe t ₁	Delikten kama kanalı derinliği Depth of key- way in hub Nabennuttiefe Ød + t ₂ DIN 6885/1 mm
	above über mm	to bis mm				
	17	22	6	6	3.5	d + 2.8
	22	30	8	7	4	d + 3.3
	30	38	10	8	5	d + 3.3
	38	44	12	8	5	d + 3.3
	44	50	14	9	5.5	d + 3.8
	50	58	16	10	6	d + 4.3
	58	65	18	11	7	d + 4.4
	65	75	20	12	7.5	d + 4.9
	75	85	22	14	9	d + 5.4
	85	95	25	14	9	d + 5.4
	95	110	28	16	10	d + 6.4
	110	130	32	18	11	d + 7.4
	130	150	36	20	12	d + 8.4
	150	170	40	22	13	d + 9.4
	170	200	45	25	15	d + 10.4
	200	230	50	28	17	d + 11.4
230	260	56	32	20	d + 12.4	
260	290	63	32	20	d + 12.4	
290	330	70	36	22	d + 14.4	
330	380	80	40	25	d + 15.4	
380	440	90	45	28	d + 17.4	

- Kamalarındaki merkezi Kama genişliği b için ağır ağır çalışma koşullarında ISO P9 veya JS9.
- The tolerance zone for the hub keyway width b for parallel keys is ISO JS9, or ISO P9 for heavy-duty operating conditions.
- Das Toleranzfeld der Nabennutbreite b für Passfedern ist ISO JS9, bzw. ISO P9 bei erschwerten Betriebsbedingungen.

TR DELİK MİLLİ KONİK SIKTIRMALI ŞAFTLAR

EN HOLLOW SHAFTS FOR SHRINK DISKS

DE HOHLWELLEN FÜR SCHRUMPFSCHEIBEN

x = Tork anahtarları için gerekli boşluk
 x = Space required for torque wrench
 x = Platzbedarf für Drehmomentschlüssel berücksichtigen

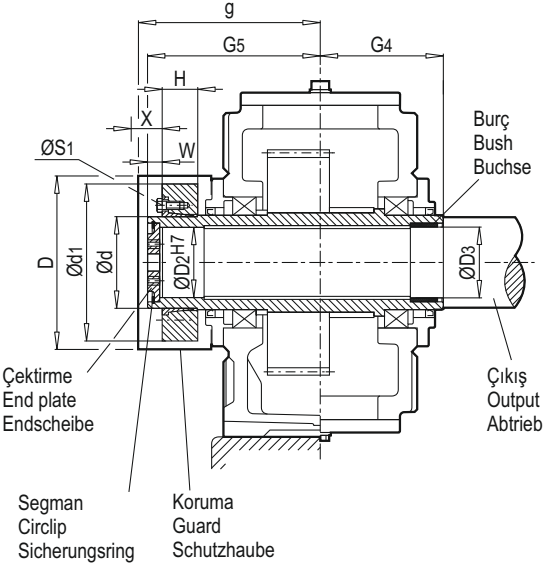

Konik sıkırtma bağlantısı yapılacak müşteri milleri mutlaka gressiz olmalıdır.
 Driven machine shaft for shrink disk connection. Driven machine shaft must be free of oil or grease.
 Arbeitsmaschinenwelle für Schrumpfscheibenverbindung, bei Montage nicht gefettet.

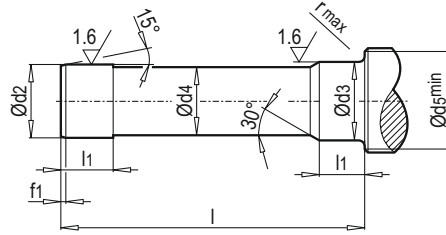

Merkez delik formu DS ile müşteri milinin (klavuz deliği) DIN 332'ye göre.
 Driven machine shaft with centre hole form DS (tapped hole) acc. to DIN 332.
 Arbeitsmaschinenwelle mit Zentrierung Form DS (mit Gewinde) nach DIN 332.

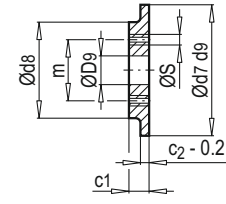

Çektirme End plate Endscheibe

Tip / Type / Bauart PB...3-H

Redüktör gövdesi Gear unit size Getriebe- größe	Müşteri mili Driven machine shaft Arbeitsmaschinenwelle															Çektirme End plate Endscheibe	Segman Circlip Sicherungsring	Delik Mil Hollow shaft Hohlwelle				Konik sıkırtma Shrink disk Schrumpfscheibe				Civata Screw Schraube	Koruma Guard Schutzhaube	
	2)																	1)										
	Ød2	Ød3	Ød4	Ød5	f1	l	l1	r	c1	c2	Ød7	Ød8	Ød9	m	Øs			Adt. Qty Anzahl	DIN 472	ØD2	ØD3	G4	G5	Ød	Ød1		H	W
mm															mm													
43	85 g6	85 h6	84.5	95	4	326	48	2	17	7	90	70	22	50	M 8	2	90 x 3	85	85	140	205	110	185	51	20	M 12	235	225
53	100 g6	100 h6	99.5	114	5	383	53	2	20	8	105	80	26	55	M 10	2	105 x 4	100	100	165	240	125	215	55	20	M 12	275	260
63	110 g6	110 h6	109.5	124	5	383	58	3	20	8	115	85	26	60	M 10	2	115 x 4	110	110	165	240	140	230	61	20	M 14	285	255
73	120 g6	120 h6	119.5	134	5	453	68	3	20	8	125	90	26	65	M 12	2	125 x 4	120	120	195	289	155	263	64	23	M 14	330	305
83	130 g6	130 h6	129.5	145	6	458	73	3	20	8	135	100	26	70	M 12	2	135 x 4	130	130	195	285	165	290	70	23	M 16	340	305
93	140 g6	145 m6	139.5	160	6	538	82	4	23	10	150	110	33	80	M 12	2	150 x 4	140	145	235	330	175	300	71	28	M 16	360	355
103	150 g6	155 m6	149.5	170	6	559	92	4	23	10	160	120	33	90	M 12	2	160 x 4	150	155	235	350	185	340	87	28	M 16	395	365
113	165 f6	170 m6	164.5	185	7	644	112	4	23	10	175	130	33	90	M 12	2	175 x 4	165	170	270	400	220	370	103	30	M 20	435	420
123	180 f6	185 m6	179.5	200	7	649	122	4	23	10	190	140	33	100	M 16	2	190 x 4	180	185	270	405	240	405	107	30	M 20	450	420
133	180 f6	195 m6	189.5	213	7	789	137	5	23	10	200	150	33	110	M 16	2	200 x 4	190	195	335	480	260	430	119	30	M 20	500	505
143	210 f6	215 m6	209.5	233	8	784	147	5	28	14	220	170	33	130	M 16	2	220 x 5	210	215	335	480	280	460	132	30	M 20	525	505
153	230 f6	235 m6	229.5	253	8	899	157	5	28	14	240	180	39	140	M 16	2	240 x 5	230	235	380	550	300	485	140	35	M 24	575	575
163	240 f6	245 m6	239.5	263	8	899	157	5	28	14	250	190	39	150	M 20	2	250 x 5	240	245	380	550	320	520	140	35	M 24	595	575
173	250 f6	260 m6	249.5	278	8	982	177	5	30	14	265	200	39	150	M 20	2	265 x 5	250	260	415	600	340	570	155	35	M 24	615	630
183	280 f6	285 m6	279.5	306	9	982	177	5	30	14	290	210	39	160	M 20	2	290 x 5	280	285	415	600	360	590	162	35	M 24	635	625

1) Konik sıkırtma tedarik alanımıza ait değil. Gerekirse, lütfen ayrıca sipariş ediniz. Sipariş olması durumunda konik sıkırtma serbest öge olarak temin edilecektir.

2) Müşteri milinin malzemesi: C60N veya daha yüksek mukavemette malzeme. Konik sıkırtma yeri makine tarafında istek üzerine

1) Shrink disk does not belong to our scope of supply. Please order separately, if required. Shrink disk will be supplied as loose item.

2) Material of driven machine shaft: C60N or higher strength. Shrink disk on machine side on request.

1) Schrumpfscheibe gehört nicht zum Lieferumfang. Bei Bedarf gesondert bestellen. Schrumpfscheibe wird lose mit geliefert.

2) Werkstoff Arbeitsmaschinenwelle C60N oder höhere Festigkeit. Schrumpfscheibe an Maschinenseite auf Anfrage.

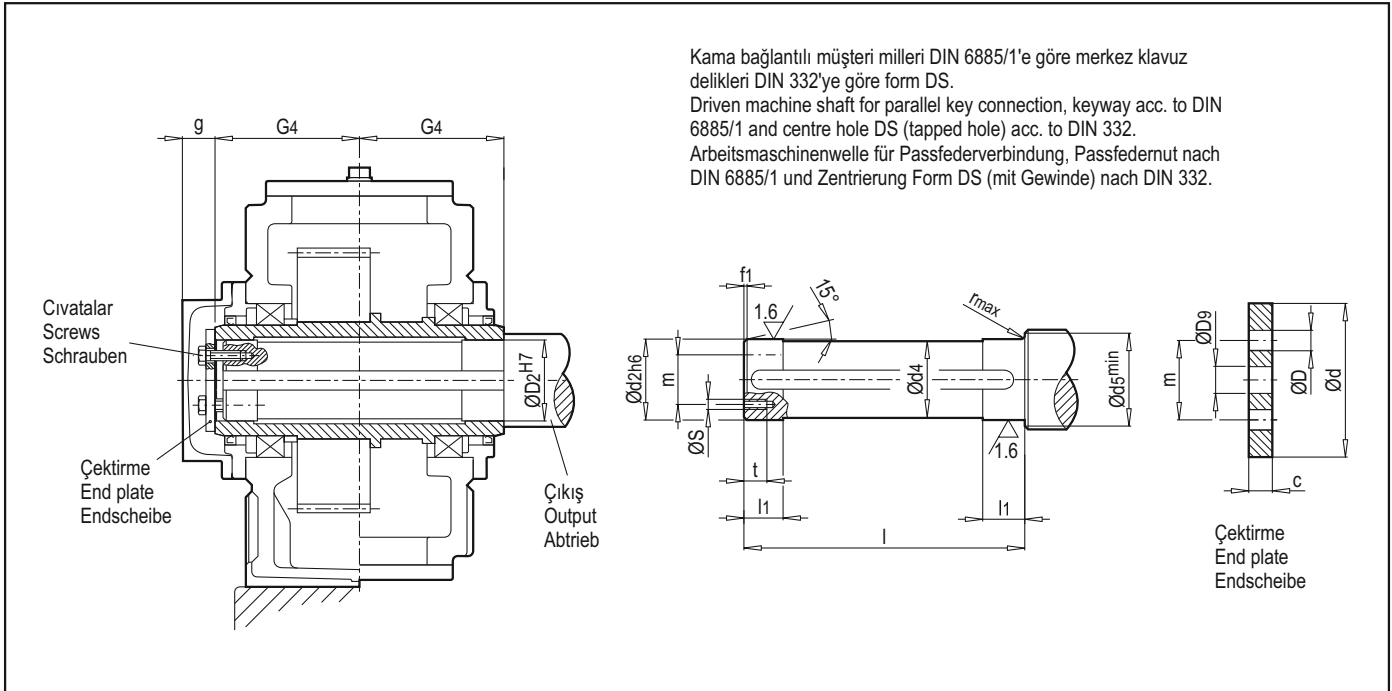

Tipler / Types / Bauarten PB...3-H

Redüktör gövdeleri Gear unit size Getriebe- größe	Müşteri mili 1) Driven machine shaft Arbeitsmaschinenwelle									Çektirme End plate Endscheibe				Cıvata Screw Schraube		Delik milli shaft Hollow shaft Hohlwelle			
	Ød2	Ød4	Ød5	f1	l	l1	r	Øs	t	c	ØD	ØD9	Ød	m	Boyut Size Größe	Adet Qty. Anzahl	ØD2	G4	g
	mm																		
PB43	80	79.5	88	4	278	35	1.2	M 10	18	10	11	22	100	60	M 10 x 25	2	80	140	35
PB53	95	94.5	105	5	328	40	1.6	M 10	18	10	11	26	120	70	M 10 x 25	2	95	165	40
PB63	105	104.5	116	5	328	45	1.6	M 10	18	10	11	26	120	70	M 10 x 25	2	105	165	40
PB73	115	114.5	126	5	388	50	1.6	M 12	20	12	13.5	26	140	80	M 12 x 30	2	115	195	40
PB83	125	124.5	136	6	388	55	2.5	M 12	20	12	13.5	26	150	85	M 12 x 30	2	125	195	40
PB93	135	134.5	147	6	467	60	2.5	M 12	20	12	13.5	33	160	90	M 12 x 30	2	135	235	45
PB103	150	149.5	162	6	467	65	2.5	M 12	20	12	13.5	33	185	110	M 12 x 30	2	150	235	45
PB113	165	164.5	177	7	537	70	2.5	M 16	28	15	17.5	33	195	120	M 16 x 40	2	165	270	45
PB123	180	179.5	192	7	537	75	2.5	M 16	28	15	17.5	33	220	130	M 16 x 40	2	180	270	45
PB133	190	189.5	206	7	667	80	3	M 16	28	18	17.5	33	230	140	M 16 x 40	2	190	335	45
PB143	210	209.5	226	8	667	85	3	M 16	28	18	17.5	33	250	160	M 16 x 40	2	210	335	45
PB153	230	229.5	248	8	756	100	3	M 20	38	25	22	39	270	180	M 20 x 55	4	230	380	60
PB163	240	239.5	258	8	756	100	3	M 20	38	25	22	39	280	180	M 20 x 55	4	240	380	60
PB173	250	249.5	270	8	826	110	4	M 20	38	25	22	39	300	190	M 20 x 55	4	250	415	60
PB183	275	274.5	295	9	826	120	4	M 20	38	25	22	39	330	210	M 20 x 55	4	275	415	60

1) Müşteri milinin malzemesi: C60N veya daha yüksek mukavemetli malzeme.

1) Material of driven machine shaft: C60N or higher strength.

1) Werkstoff Arbeitsmaschinenwelle C60N oder höhere Festigkeit.

Kama redüktörle birlikte verilmemektedir. Gerekirse, lütfen ayrıca sipariş ediniz.

Parallel key does not belong to our scope of supply. Please order separately, if required.

Passfeder gehört nicht zum Lieferumfang. Bei Bedarf gesondert bestellen.

TR

KİLİT

EN

BACKSTOPS

DE

RÜCKLAUFSPERREN

Standart kilidin montajı istenen dönme yönüne bağlıdır.
Standard backstop arrangement and dependence of direction of rotation
Standardmäßige Rücklaufsperranordnung und Drehrichtungsabhängigkeit

1)

Tip Type Bauart	Dizayn / Design / Ausführung Boyutlar / Sizes / Größen 43 ... 183	
	B	D
PB...3-SH		
PB...3-HH		
PB...3-DH		

Tip / Types / Bauarten PB...3-H			
Boyut Size Größe	E mm	G ₈ mm	ØD mm
43	270	204	129
53	315	223	154
63	350	223	154
73	385	281	179
83	430	281	179
93	450	317	194
103	500	317	194
113	545	368	237
123	615	368	237
133	635	451	277
143	705	451	277
153	762	497	323
163	808	497	323
173	860	564	413
183	920	564	413

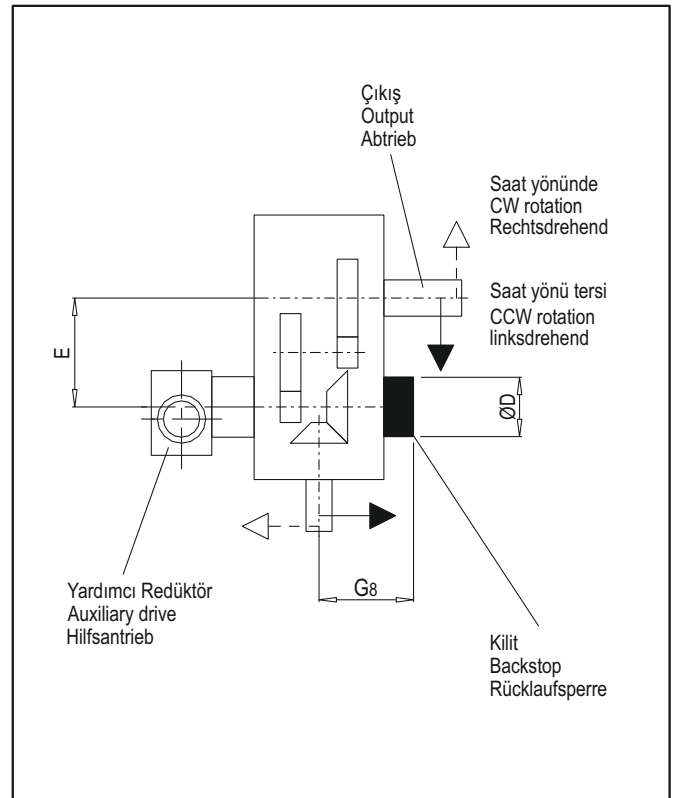

1) Diğer düzenler ve tasarımlar için lütfen bize başvurunuz.

1) For other arrangements and designs, please refer to us.

1) Bei anderer Anordnung und Ausführung bitte Rücksprache.

Kilidin montajı istenen dönme yönüne bağlıdır (sayfa 248)
Backstop arrangement and dependence of direction of rotation (page 248) 1)
Rücklaufsperrenanordnung und Drehrichtungsabhängigkeit (seite 248)

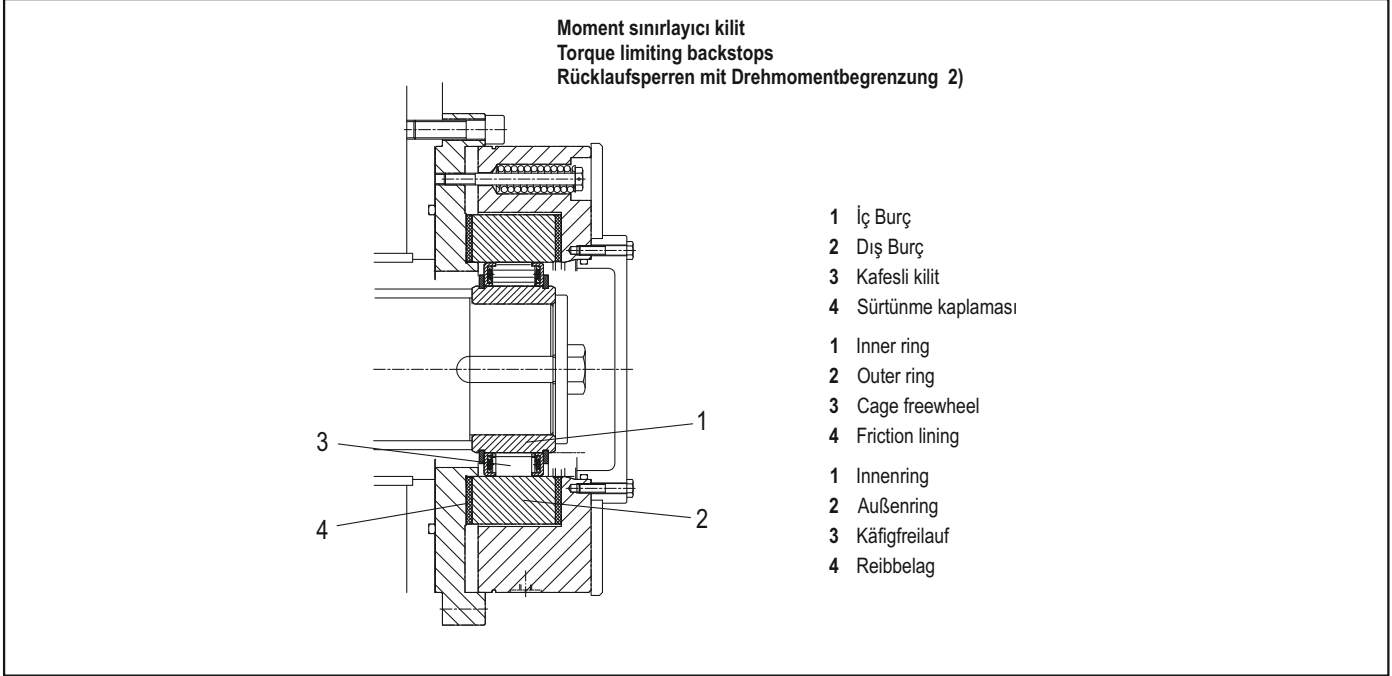

Tip / Types / Bauarten PB...3-H			
Boyut Size Größe	E mm	Gg mm	ØD mm
43	270	295	280
53	315	315	280
63	350	315	280
73	385	340	280
83	430	340	280
93	450	390	295
103	500	390	295
113	545	420	371
123	615	420	371
133	635	515	441
143	705	515	441
153	762	580	496
163	808	580	496
173	860	630	630
183	920	630	630

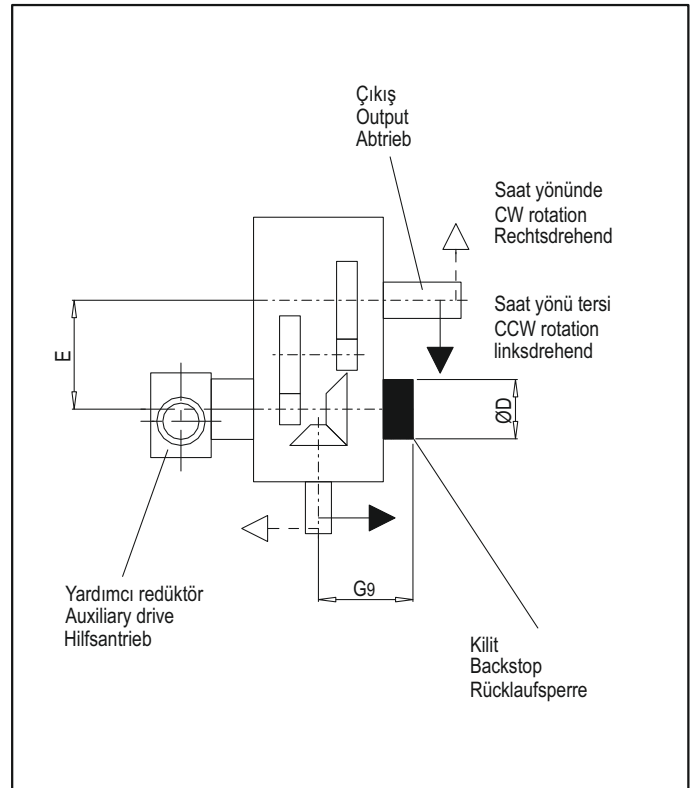

1) Diğer düzenler ve tasarımlar için lütfen bize başvurunuz.
2) Birden fazla sürücü kullanıldığı durumlarda istenmeyen geri dönüş momentleri bir dişli grubunda meydana gelebilir ve kilit buna uygun olmalıdır. Moment sınırlayıcı kilit redüktör içerisindeki dişli gruplarında oluşan maksimum geri dönüş momentlerini dağıtmaktadır.

1) For other arrangements and designs, please refer to us.
2) In case of double and multiple drives, an unacceptable concentration of restoring torque may occur on one gear unit and the backstop fitted to it. The torque limiting backstop evenly distributes the restoring torque between all gear units in a plant and in addition reduces peak torques.

1) Bei anderer Anordnung und Ausführung bitte Rücksprache.
2) Bei Doppel- und Mehrfachantrieben kann es zu einer unzulässigen Konzentration des Rückdrehmoments auf ein Getriebe und der dort angeordneten Rücklaufsperrre kommen. Die drehmomentbegrenzende Rücklaufsperrre verteilt das Rückdrehmoment gleichmäßig auf die Getriebe der Anlage und baut zusätzlich Drehmomentspitzen ab.

TR

GERÇEK TAHVİLLER

EN

ACTUAL RATIOS

DE

IST-ÜBERSETZUNGEN

Tipler / Types / Bauarten PB...3-H									
Gerçek Tahviller i / Actual ratios i / Ist-Übersetzungen i									
i _N	Redüktör Boyutları / Gear unit sizes / Getriebegrößen								
	43	53	63	73	83	93	103	113	123
25	25.380	25.421	24.349	25.446	25.152	25.843	25.400	25.185	25.103
28	27.836	27.881	27.211	28.125	27.923	28.563	27.842	27.836	27.517
31.5	30.196	30.245	31.508	30.509	32.084	30.985	32.400	31.975	32.021
35.5	34.771	34.827	34.557	35.131	35.461	35.679	35.811	34.771	35.392
40	39.487	39.551	37.486	39.896	38.468	40.902	38.846	39.861	40.654
45	43.077	43.146	43.168	43.523	44.296	44.202	44.732	43.077	44.209
50	49.060	49.139	49.021	49.568	50.304	50.341	51.280	49.060	50.681
56	55.152	55.240	53.477	55.723	54.877	56.592	55.417	55.152	54.769
63	60.808	60.906	60.904	61.438	62.499	62.396	63.114	60.808	62.376
71	69.293	69.404	68.467	70.011	70.259	71.102	70.951	69.293	70.121

Tipler / Types / Bauarten PB...3-H						
Gerçek Tahviller i / Actual ratios i / Ist-Übersetzungen i						
i _N	Redüktör Boyutları / Gear unit sizes / Getriebegrößen					
	133	143	153	163	173	183
25	25.864	25.131	24.916	24.842	25.409	25.936
28	28.587	27.548	27.847	28.263	28.398	29.507
31.5	32.838	32.057	31.634	31.588	32.259	32.979
35.5	35.709	35.432	34.400	35.883	35.080	37.463
40	40.936	40.700	39.435	39.021	40.215	40.738
45	44.238	44.259	42.617	44.732	43.460	46.702
50	50.383	50.737	48.536	48.341	49.496	50.469
56	56.639	54.831	54.562	55.055	55.641	57.479
63	62.448	62.446	60.158	61.892	61.348	64.616
71	71.161	70.200	68.553	68.239	69.909	71.243



KÜTLE ATALET MOMENTİ J₁

Redüktörün d₂ çıkış miline ilişkin kgm² cinsinden J₂ Atalet Momenti, şu formülle hesaplanır:

$J_2 = i_N^2 \times J_1$ kgm² cinsinden J₁ Atalet Momentleri, redüktörün d₁ giriş miline bağlıdır ve fansız d₁ giriş milleri için geçerlidir.

Fanlı d₁ millerinde ise J_L ilave edilir.



MASS MOMENTS OF INERTIA J₁

The mass moment of inertia J₂ in kgm² refers to the output shaft d₂ of a gear unit and is calculated with the following formula:

$J_2 = i_N^2 \times J_1$. The mass moment of inertia J₁ kgm² refers to the input shaft d₁ of a gear unit without fan.

For shaft d₁ with fan, J_L has to be added.



MASSENTRÄGHEITSMOMENTE J₁

Das auf Welle d₂ eines Getriebes bezogene Massenträgheitsmoment J₂ in kgm² wird nach folgender Formel errechnet: $J_2 = i_N^2 \times J_1$.

Die Massenträgheitsmomente J₁ in kgm² sind auf Welle d₁ der Getriebe bezogen und gelten für Welle d₁ ohne Lüfter.

Bei Welle d₁ mit Lüfter ist J_L zu addieren.

Tip / Types / Bauarten PB...3-H									
d ₁ millinin kgm ² cinsinden kütle atalet momenti J ₁ Mass moments of inertia J ₁ in kgm ² referring to shaft d ₁ / Massenträgheitsmomente J ₁ in kgm ² bezogen auf Welle d ₁									
i _N	Redüktör Boyutları / Gear unit sizes / Getriebegrößen								
	43	53	63	73	83	93	103	113	123
25	0.0039	0.0083	0.0130	0.0243	0.0356	0.0534	0.0805	0.1462	0.2270
28	0.0036	0.0077	0.0111	0.0209	0.0296	0.0452	0.0687	0.1286	0.1926
31.5	0.0029	0.0062	0.0087	0.0162	0.0253	0.0348	0.0555	0.0936	0.1539
35.5	0.0024	0.0055	0.0080	0.0137	0.0218	0.0315	0.0470	0.0837	0.1349
40	0.0019	0.0041	0.0065	0.0110	0.0169	0.0265	0.0363	0.0720	0.0983
45	0.0018	0.0039	0.0057	0.0098	0.0142	0.0227	0.0326	0.0623	0.0877
50	0.0013	0.0030	0.0043	0.0081	0.0114	0.0178	0.0274	0.0469	0.0751
56	0.0011	0.0025	0.0040	0.0068	0.0102	0.0146	0.0235	0.0384	0.0649
63	0.00087	0.0021	0.0031	0.0059	0.0084	0.0124	0.0184	0.0326	0.0489
71	0.00067	0.0016	0.0026	0.0047	0.0070	0.0100	0.0150	0.0262	0.0400
J _L	0.006	0.010	0.010	0.020	0.020	0.045	0.045	0.100	0.100

Tip / Type / Bauart PB...3-H						
d ₁ millinin kgm ² cinsinden kütle atalet momenti J ₁ Mass moments of inertia J ₁ in kgm ² referring to shaft d ₁ / Massenträgheitsmomente J ₁ in kgm ² bezogen auf Welle d ₁						
i _N	Redüktör Boyutları / Gear unit sizes / Getriebegrößen					
	133	143	153	163	173	183
25	0.3196	0.4938	0.9016	1.1644	1.9196	2.4645
28	0.2714	0.4189	0.7728	0.9159	1.6758	1.9474
31.5	0.2004	0.3317	0.5615	0.7842	1.2159	1.6981
35.5	0.1819	0.2812	0.5062	0.5703	1.0968	1.2332
40	0.1539	0.2079	0.4306	0.5137	0.9481	1.1114
45	0.1312	0.1882	0.3694	0.4363	0.8188	0.9592
50	0.1028	0.1587	0.2765	0.3743	0.5713	0.8283
56	0.0853	0.1353	0.2284	0.2802	0.4692	0.5787
63	0.0725	0.1060	0.1956	0.2314	0.4054	0.4750
71	0.0585	0.0878	0.1587	0.1981	0.3333	0.4101
J _L	0.290	0.290	0.290	0.290	0.690	0.690

TR

 TALEP EDİLDİĞİNDE EKLENEBİLEN
 SEÇENEKLER

EN

 ADDITIONAL VARIANTS INFORMATION
 ON REQUEST

DE

 ZUSÄTZLICHE VARIANTEN
 INFORMATIONEN AUF ANFRAGE

 Şaft keçesi varyasyonları
 Variants of shaft seals
 Wellenabdichtungsvarianten

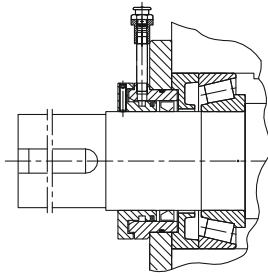
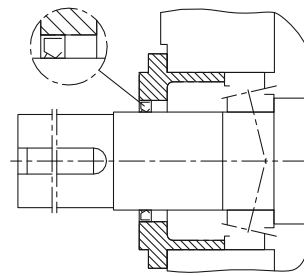
 Takonite keçe
 Taconite seals
 Taconite-Dichtungen

 Şaft keçesi
 Radial shaft seals
 Radialwellendichtringe

 Redüktörlerde titreşim
 Gear unit swing-bases
 Getriebeschwingen

 Standart motor
 Standard motor
 Normmotor

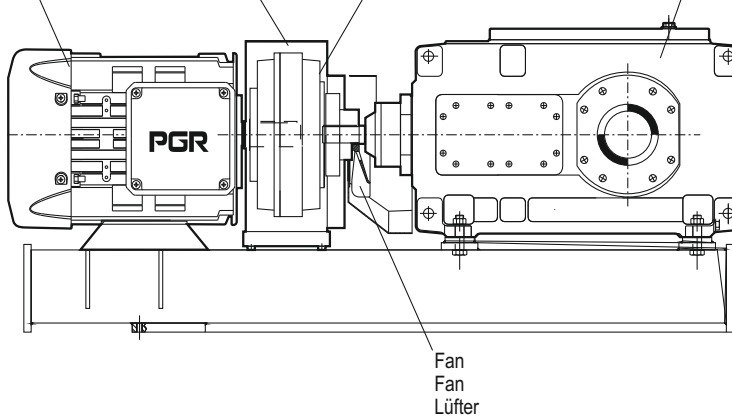
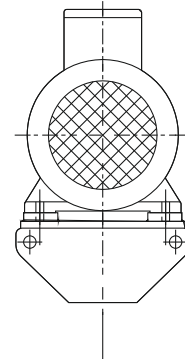
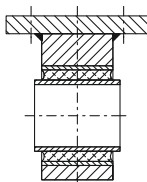
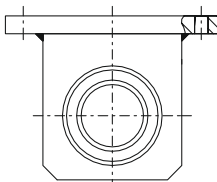
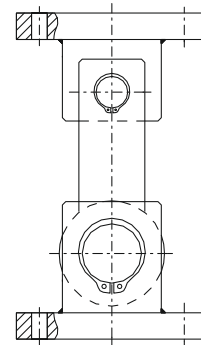
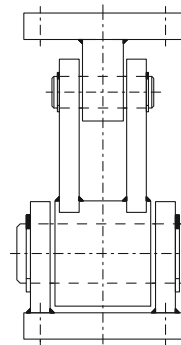
 Koruma
 Guard
 Schutzhaube

 Kaplin F
 F Coupling
 F Kupplung

 Konik dişli redüktör
 Bevel-helical gear unit
 Kegelstirradgetriebe

 Fan
 Fan
 Lüfter

 Redüktör titreşimindeki destek ekipmanları
 Supports for gear unit swing-bases
 Abstützungen für Getriebeschwingen

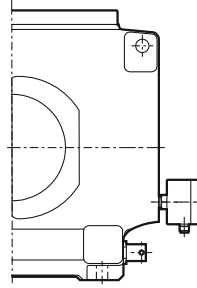
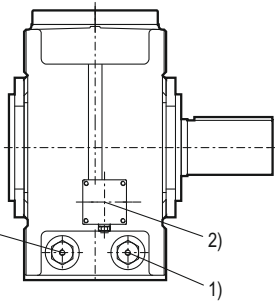
 Elastik destek
 Flexible pedestal
 Stützbock elastisch

 Tork kolu
 Torque arm
 Drehmomentstützen

Boyut / Sizes
Größen 43 ... 123

Gövdeler dışında
43, 63, 83, 103, 123
Except for sizes
43, 63, 83, 103, 123
Entfällt bei Größen
43, 63, 83, 103, 123



Boyut / Sizes
Größen 133 ... 183

Gövdeler dışında
143, 163, 183
Except for sizes
143, 163, 183
Entfällt bei Größen
143, 163, 183

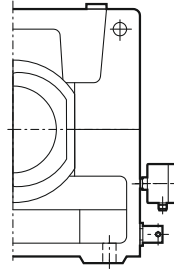
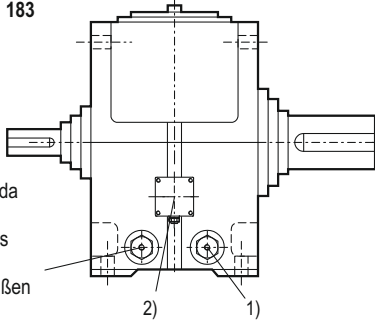

- 1) Isıtma elementi teknik bilgileri;
Koruma sınıfı IP 65, 230V 50Hz, performansı kullanım şartlarına göre değişir (Lütfen bizimle iletişime geçiniz).
- 2) Isı göstergesi teknik bilgiler (ATH-SW22);
Koruma sınıfı IP 65, iki kademeli ayarlanabilir şalter maksimum kapasitesi:
2A/230 V AC/460 VA cos $\Phi=0.6$ (alternatif akım)
0.25 A / 230 V DC/58 W (direk akım)

- 1) Screwed heating element; Technical data and notes: Type of protection IP 65, 230 V, 50 Hz, power rating acc. to design. (Please refer to us)
- 2) Temperature monitor ATH-SW22; Technical data and notes: Type of protection IP 65, 2 change-over contacts (adjustable), max. switching capacity:
2 A/230 V AC/460 VA cos $\Phi = 0.6$ (alternating current),
0.25 A/230 V DC/58 W (direct current)

- 1) Einschraubheizkörper, Technische Daten und Hinweise: Schutzartl P65,230V,50Hz, Leistung je nach Auslegung (Rückfrageerforderlich)
- 2) Temperaturwächter ATH-SW22, Technische Daten und Hinweise: Schutzart IP 65,2 Umschaltkontakte (einstellbar), maxSchaltleistung:
2A/230VAC/460VAcos $\Phi=0,6$ (Wechselspannung),
0,25A/230VDC/58W(Gleichspannung)



A large area of the page is filled with horizontal dotted lines, providing a template for writing or drawing.



POLAT GROUP REDÜKTÖR SAN. ve TİC. A.Ş.

- ATA OSB Mah. Astim 1.Cad. No: 4 Efeler - Aydın / TÜRKİYE
- T: +90 256 231 19 12 • F: +90 256 231 19 17 • info@pgr.com.tr • www.pgr.com.tr

Dok. No: PG.KT.GT.008

Rev. / Yayın Tarihi: 12.2025_R1