



PYK SERIES

Yatay ve Dikey Yem Karma
Redüktörleri

Feeder Mixer Drives for
Horizontal and Vertical



Kataloğumuzda yer alan bilgileri, önceden haber vermeksizin kısmen veya tamamen deęiřtirme veya iptal etme hakkını saklı tutmaktayız /
We reserve the right to our company to make changes or modifications to catalogue without prior notice.

PGR[®]
DRIVE TECHNOLOGIES

TR

YEM KARMA REDÜKTÖRLERİ

Hayvan yetiştirmede üretimi arttırmak için besleyici yeme ihtiyaç duyulmaktadır. Besleyici yemi oluşturan bileşenleri iyi bir şekilde karıştırmak ve istenilen büyüklükte parçalamak için yem karma makineleri kullanılmaktadır. Kaliteli yem üretimi için verimli karma işlemi önemli bir adımdır.

Yem karma makinelerinde, yemin parçalanması ve karıştırılması sırasında, değişken ve ani yüklenmeler oluşmaktadır ve bu yüzden yüksek kuvvetler gerekmektedir. Bu yüksek güç ve dayanımın ihtiyacı, zor şartlarda çalışacak şekilde dizayn edilmiş ve kaliteyi garanti eden üretim süreçlerinden geçmiş aktarma elemanlarının kullanımıyla sağlanabilir.

PGR, yatay ve dikey yem karma makinelerinin tüm kapasiteleri için özel olarak dizayn edilmiş, geniş tahvil aralığına sahip modüler planet redüktörler ile ekonomik çözümler sunmaktadır ve tarım endüstrisinde hayvan yemi karıştırıcılarının çalışma gereksinimlerine cevap verebilmek için modifiye edilmiştir.



Bu yüksek verimli yem karma redüktörleri, tasarımın esnekliğinden kaynaklı kullanıcılara çok çeşitli opsiyonlar sağlamaktadır. Eş eksenli ve konik seçeneklerin haricinde motorun flanş ile direkt olarak redüktöre montaj imkanı sağlanmaktadır.

Isıl işlem görmüş, yüksek yüzey kalitesine sahip, dövme çelik malzemeler ile imal edilmiş, istenilen çıkış oranlarına sahip PGR yem karma redüktörlerinde, standartlara uygun, erkek/dişi alternatifli giriş ve çıkışlar sunulmaktadır.

Yem karma redüktörleri, PGR'nin standart planet redüktör teknolojisinin avantajlarının bileşenidir. Bu redüktörler, ihtiyaçlarınızı karşılayacak şekilde kolayca ayarlanabilir ve çok sayıda yeni fikir ve iyileştirme içerir.



EN

FEEDER MIXER DRIVES

In raising of animals, for the purpose of increasing production, nutritive feed is needed. The feed mixing machines are used for mixing components properly which generate nutritive feed and for breaking them as an intended size. To the quality feed production, efficient mixing process is an important step.

At feed mixing machines, during the breaking and mixing of feed, the variable and sudden overloading are occurred and because of this, high forces are required. This high force and resistance necessity could be provided with the use of connecting elements which are designed to operate at hard working conditions and to have passed from the production processes that guarantee the quality.

PGR would present economic solutions with modular planet gearboxes specifically designed, which has broad ratio for all capacities of both horizontal and vertical feed mixing machines and are modified to meet operating requirements of animal feed mixers at the agriculture industry.

These high-efficient feed mixing gearboxes provide several options to the users because of it's design of flexible base. Apart from coaxial and conical choices, it ensures opportunity to assemble motor directly to the gearbox with the help of flange.

Experiencing heat treating with high surface quality, produced with forged steel elements, own required output rates, at PGR feed mixing gearboxes, suitable to the standards male/female alternative inputs and outputs are offered.

The feed mixing gearboxes are the component of advantages of the PGR's standard Planet Gearbox technology. These gearboxes are easily adjustable to meet your requirements and include numerous idea and improvement.



A series of horizontal dotted lines spanning the width of the page, intended for writing or drawing.

PYK Dikey Yem Karma Redüktörleri

PYK Feed Mixing Gearboxes
For Vertical Type



PYK (Dikey)
PYK (Vertical)

PYK 1602

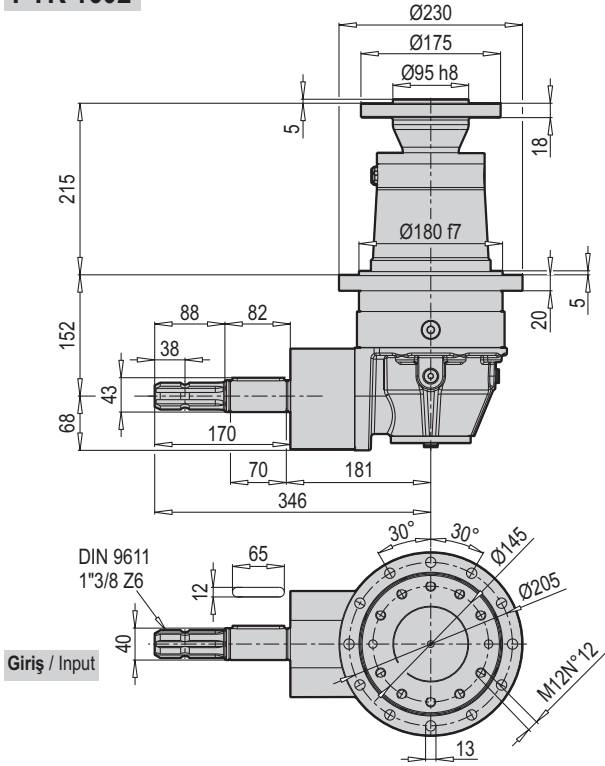

Tahvil Ratio i	Giriş Mili Input Shaft DIN 9611	Giriş Devri Input Speed [rpm]	M ₁ nominal [Nm]	M ₂ nominal [Nm]	M ₂ max [Nm]
10.43	1"3/8 Z6	540	168	1750	3500
12.56			139	1750	3500
16.40			76	1250	2500
19.77			52	1025	2050

* Farklı giriş ve çıkış milleri mevcuttur. (Örn: 1"3/4 Z20) / Different input and output shafts available. (Exp: 1"3/4 Z20)

* İsteğe bağlı olarak farklı tahvil değerleri yapılabilir. / Different ratio values could be done upon request.

* Daha fazla bilgi için lütfen PGR satış departmanı ile irtibata geçiniz. / For more information please contact the PGR Sales Dept.

PYK 2502

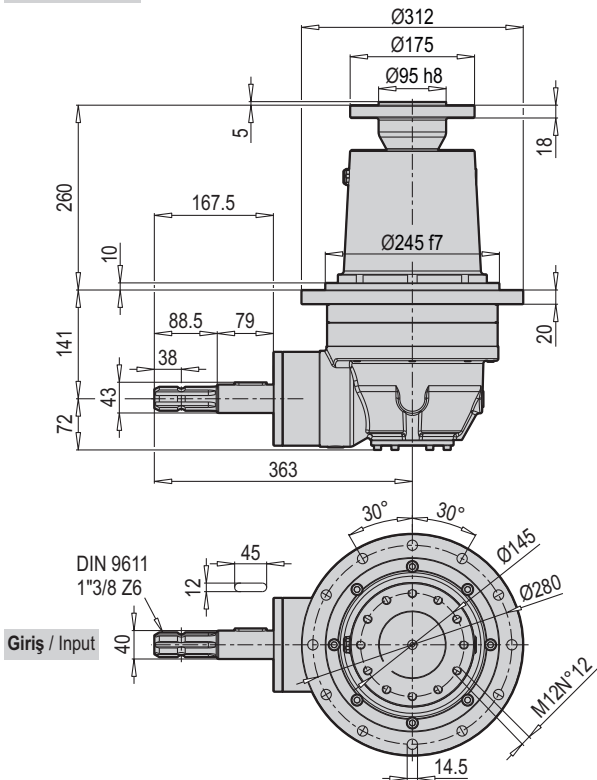

Tahvil Ratio i	Giriş Mili Input Shaft DIN 9611	Giriş Devri Input Speed [rpm]	M ₁ nominal [Nm]	M ₂ nominal [Nm]	M ₂ max [Nm]
8.72	1"3/8 Z6	540	413	3600	7200
9.53			341	3250	6500
11.93			226	2700	5400
13.85			162	2250	4500
16.73			105	1750	3500

* Farklı giriş ve çıkış milleri mevcuttur. (Örn: 1"3/4 Z20) / Different input and output shafts available. (Exp: 1"3/4 Z20)

* İsteğe bağlı olarak farklı tahvil değerleri yapılabilir. / Different ratio values could be done upon request.

* Daha fazla bilgi için lütfen PGR satış departmanı ile irtibata geçiniz. / For more information please contact the PGR Sales Dept.

PYK 5002

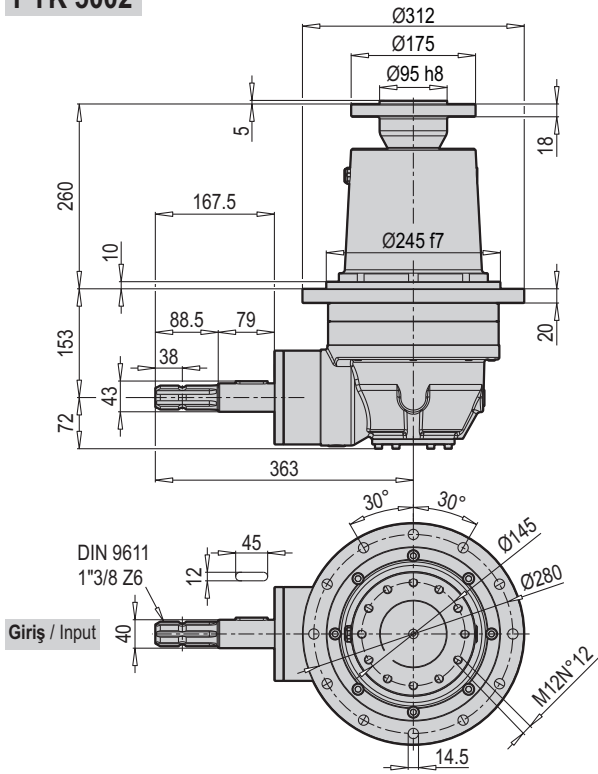

Tahvil Ratio i	Giriş Mili Input Shaft DIN 9611	Giriş Devri Input Speed [rpm]	M ₁ nominal [Nm]	M ₂ nominal [Nm]	M ₂ max [Nm]
8.72	1"3/8 Z6	540	596	5200	10400
9.53			498	4750	9500
11.93			327	3900	7800
13.85			245	3400	6800
16.73			158	2650	5300

* Farklı giriş ve çıkış milleri mevcuttur. (Örn: 1"3/4 Z20) / Different input and output shafts available. (Exp: 1"3/4 Z20)

* İsteğe bağlı olarak farklı tahvil değerleri yapılabilir. / Different ratio values could be done upon request.

* Daha fazla bilgi için lütfen PGR satış departmanı ile irtibata geçiniz. / For more information please contact the PGR Sales Dept.

PYK 7002

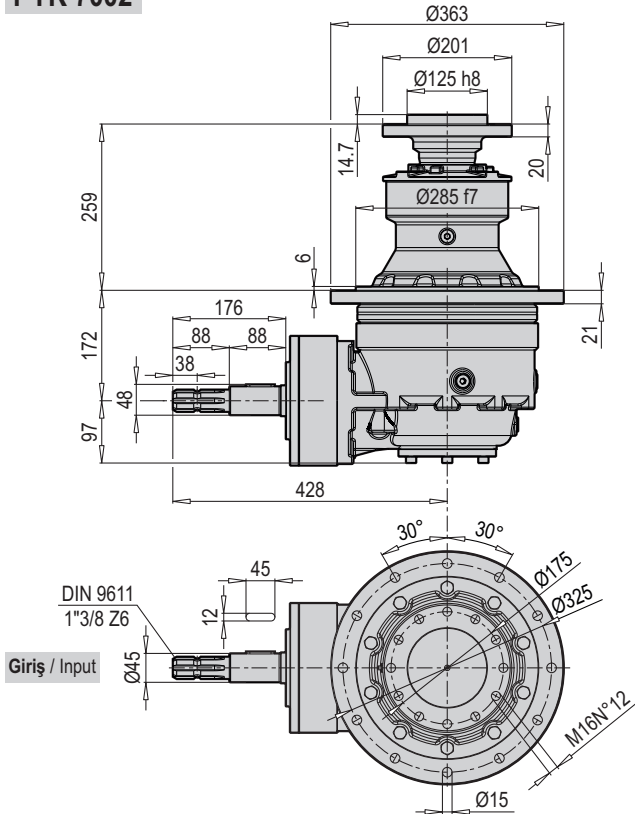

Tahvil Ratio i	Giriş Mili Input Shaft DIN 9611	Giriş Devri Input Speed [rpm]	M ₁ nominal [Nm]	M ₂ nominal [Nm]	M ₂ max [Nm]
12.11	1"3/8 Z6	540	590	7150	14300
14.62			445	6500	13000
16.50			345	5700	11400
19.14			253	4850	9700
23.10			169	3900	7800

* Farklı giriş ve çıkış milleri mevcuttur. (Örn: 1"3/4 Z20) / Different input and output shafts available. (Exp: 1"3/4 Z20)

* İsteğe bağlı olarak farklı tahvil değerleri yapılabilir. / Different ratio values could be done upon request.

* Daha fazla bilgi için lütfen PGR satış departmanı ile irtibata geçiniz. / For more information please contact the PGR Sales Dept.

PYK 72

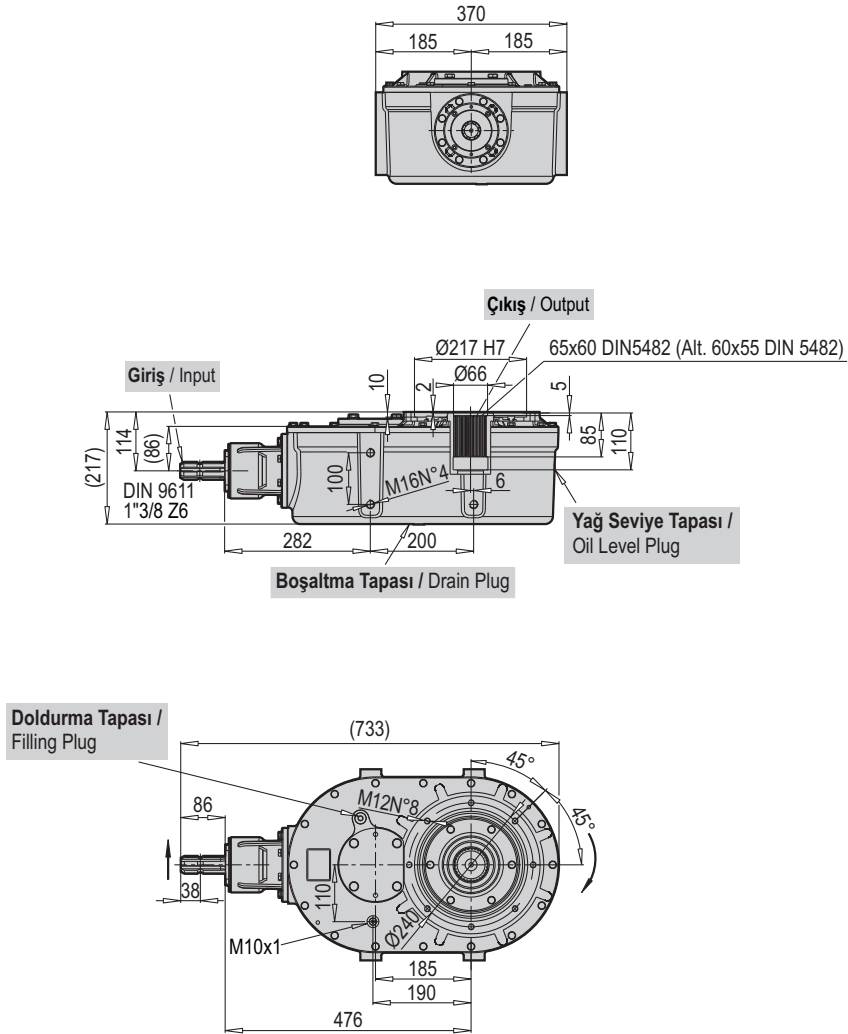

Tahvil Ratio i	Giriş Mili Input Shaft DIN 9611	Giriş Devri Input Speed [rpm]	M ₁ nominal [Nm]	M ₂ max [Nm]
10.18	1"3/8 Z6	540	963	9800
11.80			831	
12.75			769	
13.81			710	
15.02			652	

* Farklı giriş ve çıkış milleri mevcuttur. (Örn: 1"3/4 Z20) / Different input and output shafts available. (Exp: 1"3/4 Z20)

* İsteğe bağlı olarak farklı tahvil değerleri yapılabilir. / Different ratio values could be done upon request.

* Daha fazla bilgi için lütfen PGR satış departmanı ile irtibata geçiniz. / For more information please contact the PGR Sales Dept.

PYK 10002

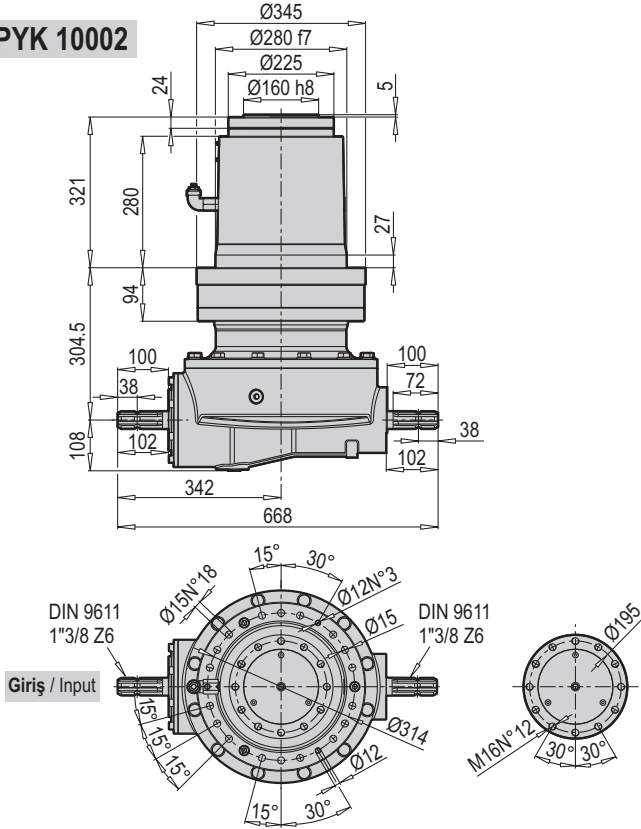

Tahvil Ratio i	Giriş Mili Input Shaft DIN 9611	Giriş Devri Input Speed [rpm]	M ₁ nominal [Nm]	M ₂ nominal [Nm]	M ₂ max [Nm]
13.42	1 3/8 Z6	540	928	12450	24900
16.17			662	10700	21400
21.11			393	8300	16600
25.44			250	6350	12700

* Farklı giriş ve çıkış milleri mevcuttur. (Örn: 1 3/4 Z20) / Different input and output shafts available. (Exp: 1 3/4 Z20)

* İsteğe bağlı olarak farklı tahvil değerleri yapılabilir. / Different ratio values could be done upon request.

* Daha fazla bilgi için lütfen PGR satış departmanı ile irtibata geçiniz. / For more information please contact the PGR Sales Dept.

PYK 18002-A

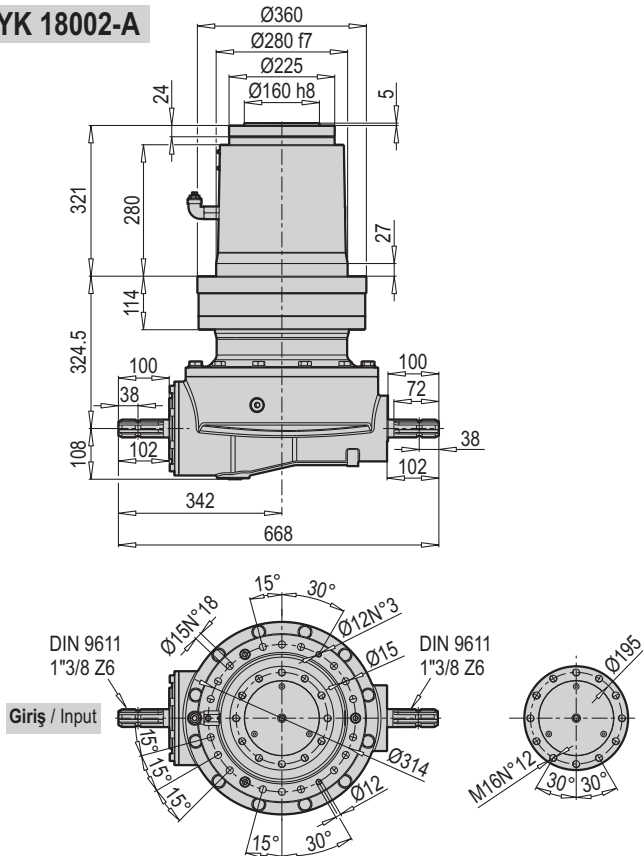

Tahvil Ratio i	Giriş Mili Input Shaft DIN 9611	Giriş Devri Input Speed [rpm]	M ₁ nominal [Nm]	M ₂ nominal [Nm]	M ₂ max [Nm]
13.42	1 3/8 Z6	540	1371	18400	36800
16.17			989	16000	32000
21.11			580	12250	24500
25.44			366	9300	18600

* Farklı giriş ve çıkış milleri mevcuttur. (Örn: 1 3/4 Z20) / Different input and output shafts available. (Exp: 1 3/4 Z20)

* İsteğe bağlı olarak farklı tahvil değerleri yapılabilir. / Different ratio values could be done upon request.

* Daha fazla bilgi için lütfen PGR satış departmanı ile irtibata geçiniz. / For more information please contact the PGR Sales Dept.

PYK 18002-B

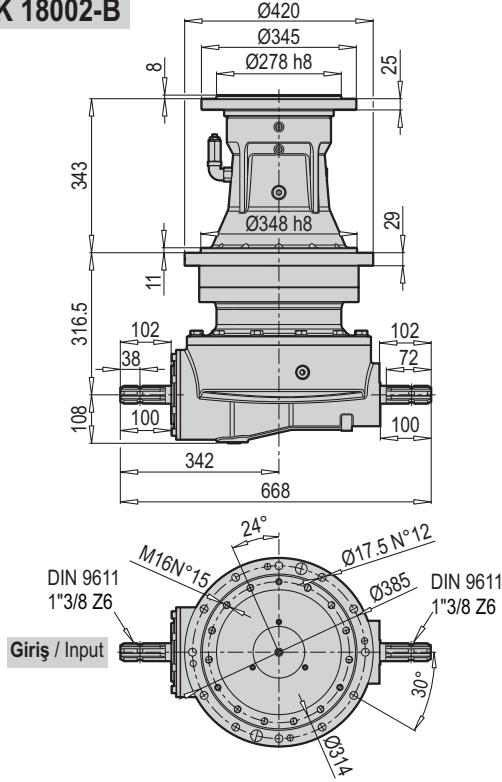

Tahvil Ratio i	Giriş Mili Input Shaft DIN 9611	Giriş Devri Input Speed [rpm]	M ₁ nominal [Nm]	M ₂ nominal [Nm]	M ₂ max [Nm]
13.42	1"3/8 Z6	540	1371	18400	36800
16.17			989	16000	32000
21.11			580	12250	24500
25.44			366	9300	18600

* Farklı giriş ve çıkış milleri mevcuttur. (Örn: 1"3/4 Z20) / Different input and output shafts available. (Exp: 1"3/4 Z20)

* İsteğe bağlı olarak farklı tahvil değerleri yapılabilir. / Different ratio values could be done upon request.

* Daha fazla bilgi için lütfen PGR satış departmanı ile irtibata geçiniz. / For more information please contact the PGR Sales Dept.

PYK 25002

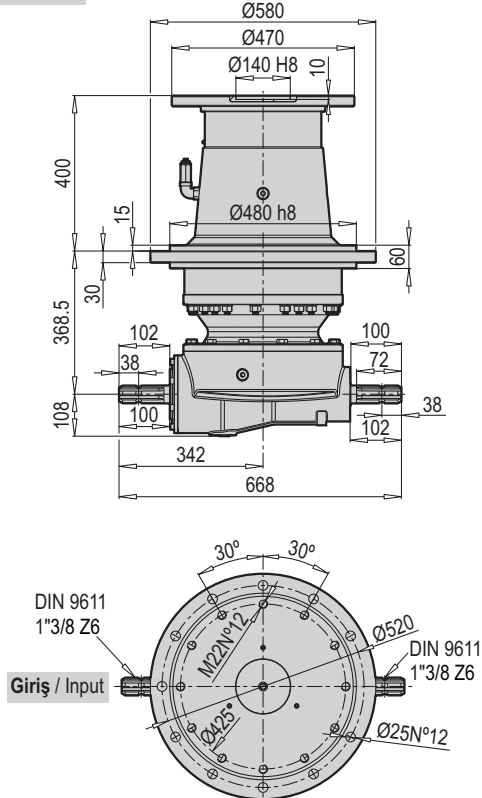

Tahvil Ratio i	Giriş Mili Input Shaft DIN 9611	Giriş Devri Input Speed [rpm]	M ₁ nominal [Nm]	M ₂ nominal [Nm]	M ₂ max [Nm]
15.08	1"3/8 Z6	540	2082	31400	62800
19.60			1237	24250	48500
23.56			796	18750	37500

* Farklı giriş ve çıkış milleri mevcuttur. (Örn: 1"3/4 Z20) / Different input and output shafts available. (Exp: 1"3/4 Z20)

* İsteğe bağlı olarak farklı tahvil değerleri yapılabilir. / Different ratio values could be done upon request.

* Daha fazla bilgi için lütfen PGR satış departmanı ile irtibata geçiniz. / For more information please contact the PGR Sales Dept.

TR ALTERNATİF DİKEY YEM KARMA REDÜKTÖRLERİ

EN ALTERNATIVE FEED MIXING GEARBOXES FOR VERTICAL TYPE

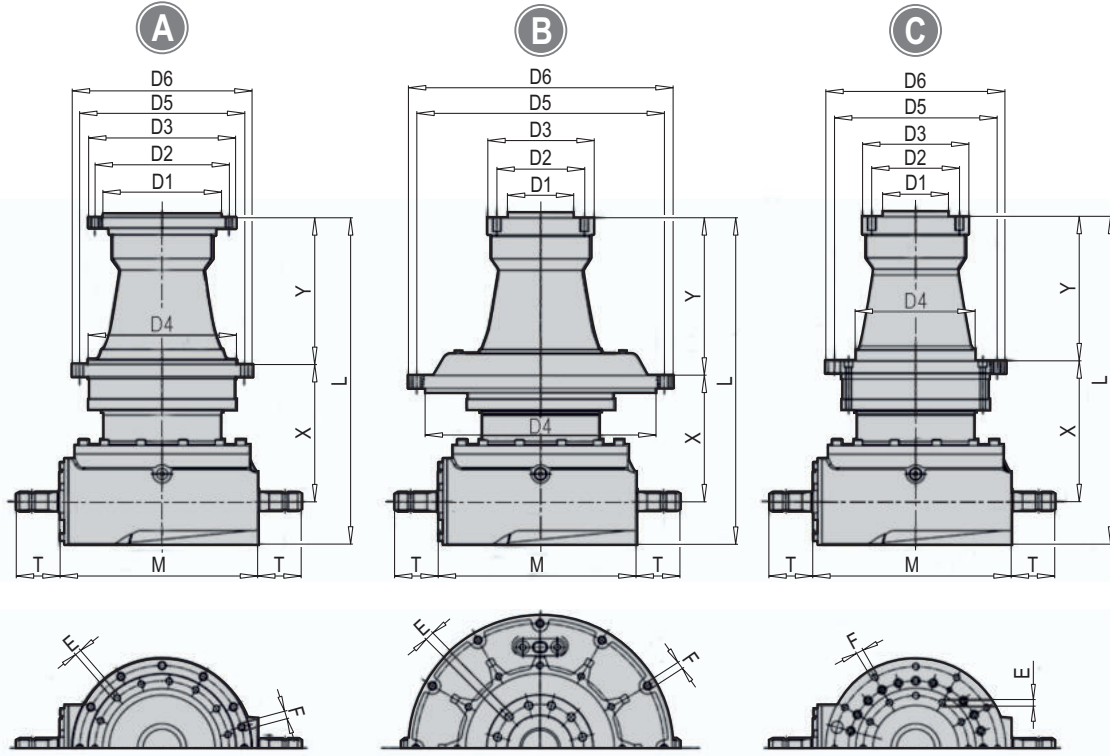

Gövde Boyutu Gear Unit Size	Tip Type	Ölçüler / Measurements (mm)												
		D1	D2	D3	E	D4	D5	D6	F	L(*)	X(*)	Y	M	T
PLB 2502 YK	C	140 h8	160	185	M16 x N°12	190 f7	220	245	Ø10.5 x N°16	483	209	192	261	82
PLB 5002 YK	C	140 h8	160	185	M16 x N°12	190 f7	220	245	Ø10.5 x N°16	495	221	192	261	82
PLB 10002/3 YK	C	160 h8	195	225	M16 x N°12	280 f7	314	345	Ø15 x N°18	690/760	254.7/327	321	465	105
PLB 12002 YK	C	160 h8	195	225	M16 x N°12	280 f7	314	345	Ø15 x N°16	670	254.5	321	377	102
PLB 16002/3 YK	A	278 f7	314	345	M16 x N°15	348 f7	385	420	Ø17 x N°12	765/840	321.5/394	343	465	102
	B	154.8 h8	205	250	M20 x N°12	540 f7	580	620	Ø17.5 x N°12	765/840	265/337.5	399	465	102
	C	154.8 h8	205	250	M20 x N°12	348 f7	385	420	Ø17 x N°12	765/840	321.5/394	342.5	465	102
PLB 17002/3 YK	A	278 f7	314	345	M16 x N°15	348 f7	385	420	Ø17 x N°12	765/840	321.5/394	343	465	102
	B	154.8 h8	205	250	M20 x N°12	540 f7	580	620	Ø17.5 x N°12	765/840	266/337.5	399	465	102
	C	154.8 h8	205	250	M20 x N°12	348 f7	385	420	Ø17 x N°12	765/840	321.5/394	342.5	465	102
PLB 21002/3 YK	A	278 f7	314	345	M16 x N°20	348 f7	385	420	Ø17 x N°23	785/855	321.5/394	343	465	102
	B	154.8 h8	205	250	M20 x N°18	540 f7	580	620	Ø17.5 x N°12	785/855	265/337.7	399	465	102
	C	154.8 h8	205	250	M20 x N°18	348 f7	385	420	Ø19 x N°12	785/855	321.5/394	342.5	465	102
PLB 25002 YK	A	140 h8	425	470	M22 x N°12	480 f7	520	580	Ø25 x N°12	870	368.5	400	465	102
PLB 30003/4 YK	A	140 h8	425	470	M22 x N°12	480 f7	520	580	Ø25 x N°12	1030	527.5	400	465	102
PLB 42003 YK	A	140 h8	425	470	M22 x N°24	480 f7	520	580	Ø25 x N°24	1085	584	400	465	102

(*) İlk değer 2 kademeyi, ikinci değer 3 kademeyi ifade eder.

(*) Initial value refers to the two stages where as second value refers to the three stages.

Gövde Boyutu Gear Unit Size	Nominal Giriş Momenti Nominal Input Moment Nm	Maximum Moment Nm	Giriş Hızı Input Speed rpm	Tahvil / Ratio (min-max) i	Şaft Profil Girişi Shaft Profile Input
PLB 5002	3.810	7.620	540	12.36-15.51	1"3/8 Z6
PLB 10002/3	8.500	17.000	540	18.8-30.6	1"3/4 Z20
PLB 12002	11.600	23.200	540	11.1-19.4 (*)	1"3/4 Z20
PLB 16002/3	15.700	31.400	540	13.4-47.5	1"3/4 Z20
PLB 17002/3	15.700	31.400	540	13.4-47.5	1"3/4 Z20
PLB 21002/3	21.000	47.000	540	12.1-62.1	1"3/4 Z20
PLB 25002	23.780	48.000	540	13.6-23.6(*)	1"3/4 Z20
PLB 30003/4	30.760	61.520	540	25.7-84.4	1"3/4 Z20
PLB 42003	42.000	142.000	540	27.8-91.4	1"3/4 Z20

(*) Sürekli çalışma moment değerleri ile maximum dayanım momentleri farklılık gösterebilir.

(*) The continuous working moment values and maximum resistance values may display diversity with each other



A large area of the page is filled with horizontal dotted lines, providing a template for writing or drawing.

PYK Yatay Yem Karma Redüktörleri

PYK Feed Mixing Gearboxes
For Horizontal Type

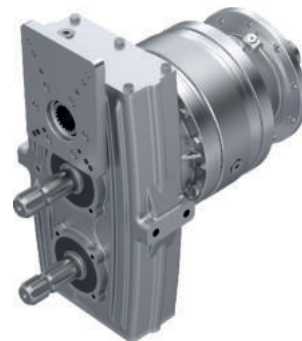

PYK (Yatay)
PYK (Horizontal)

PYK PL 5002 MS

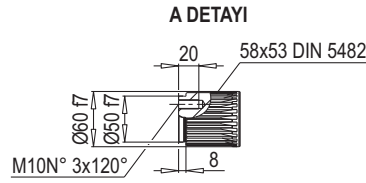
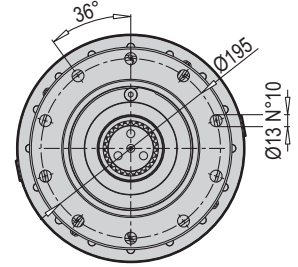
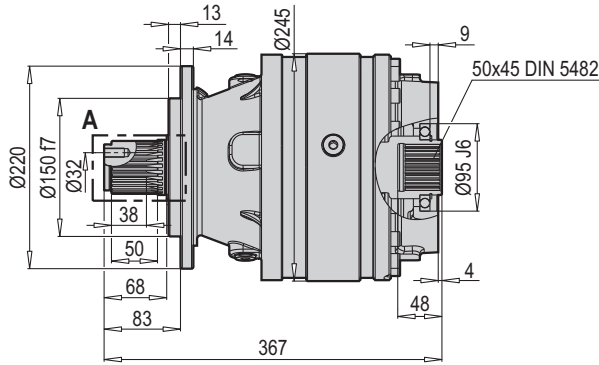
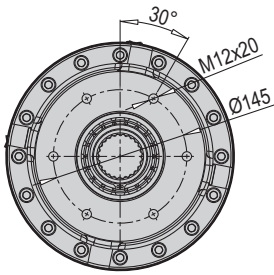

Tahvil Ratio i	Giriş Mili Input Shaft	Çıkış Mili Output Shaft	M ₂ max [Nm]
15.6	1"3/8 Z6	58x53 DIN 5482	10400
17.1			9500
21.4			7800
24.8			6800

* İsteğe bağlı olarak farklı tahvil değerleri yapılabilir.
Different ratio valves could be done upon request.

PYK PL 5002 MS + 52

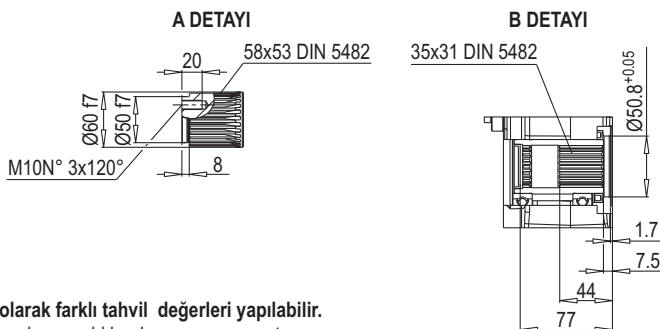
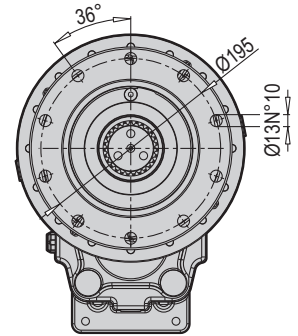
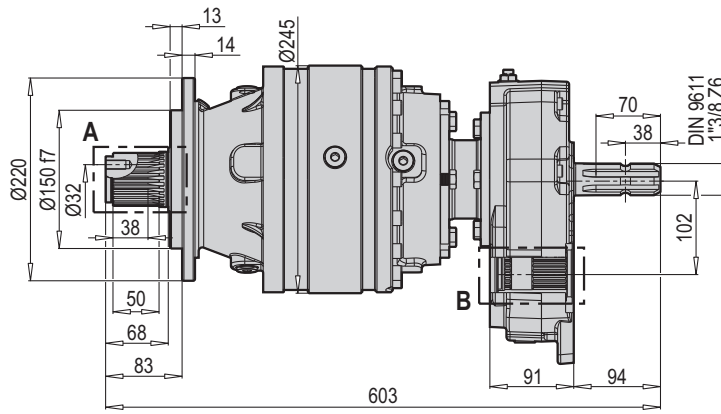
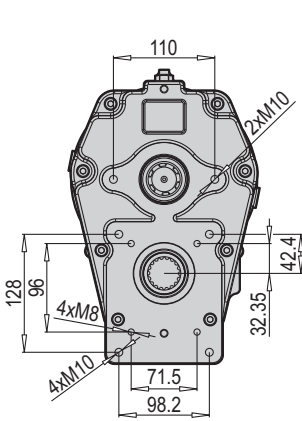

Tahvil Ratio i	Giriş Mili Input Shaft	Çıkış Mili Output Shaft	M ₂ max [Nm]
15.6	1"3/8 Z6	58x53 DIN 5482	10400
17.1			9500
21.4			7800
24.8			6800

* İsteğe bağlı olarak farklı tahvil değerleri yapılabilir.
Different ratio valves could be done upon request.

PYK PL 5002 MS + SG

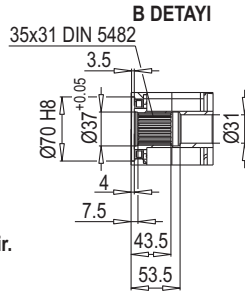
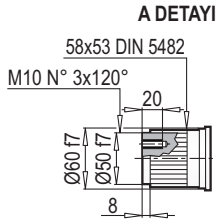
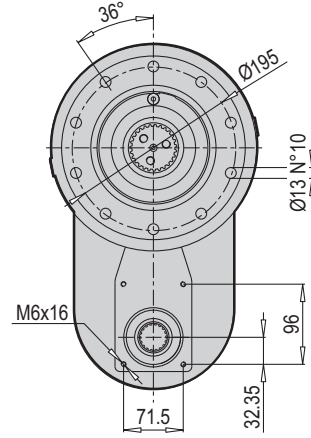
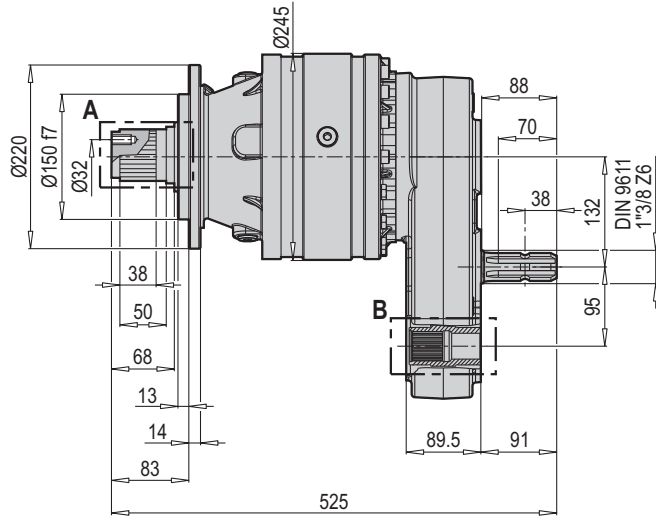

* İsteğe bağlı olarak farklı tahvil değerleri yapılabilir.
Different ratio valves could be done upon request.

Tahvil Ratio i	Giriş Mili Input Shaft	Çıkış Mili Output Shaft	M ₂ max [Nm]
15.6	1"3/8 Z6	58x53 DIN 5482	10400
17.1			9500
21.4			7800
24.8			6800

PYK PL 5002 MS + DB

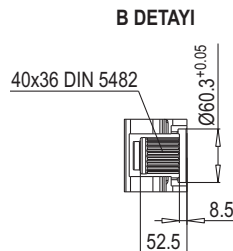
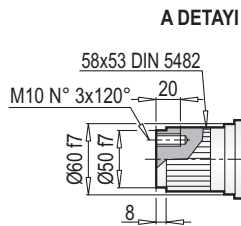
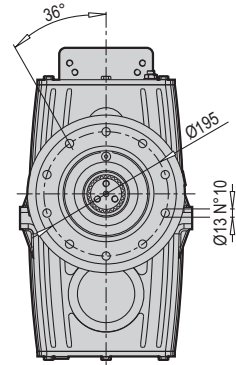
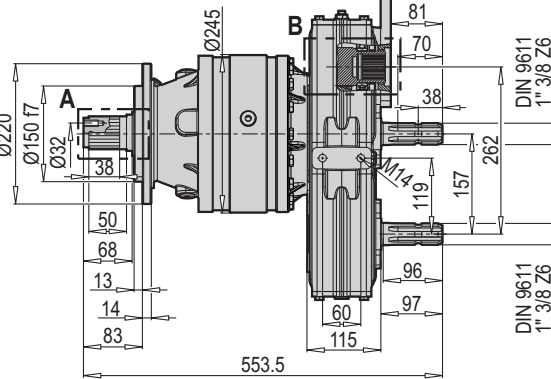
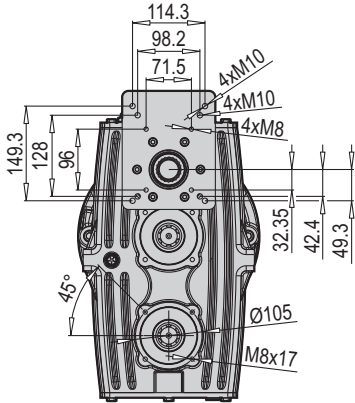

* İsteğe bağlı olarak farklı tahvil değerleri yapılabilir.
Different ratio valves could be done upon request.

Tahvil Ratio i	Giriş Mili Input Shaft	Çıkış Mili Output Shaft	M ₂ max [Nm]
15.6	1"3/8 Z6	58x53 DIN 5482	10400
17.1			9500
21.4			7800
24.8			6800

PYK PL 5002 PS

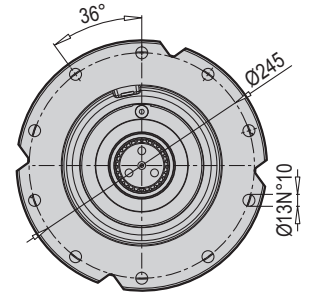
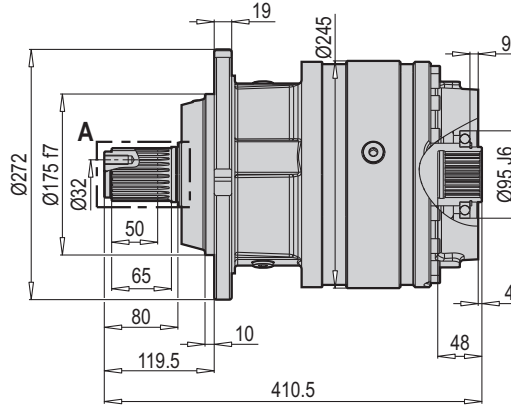
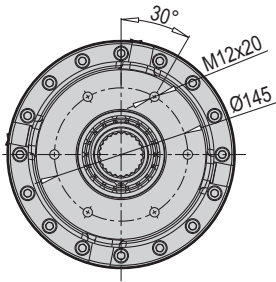

A DETAYI

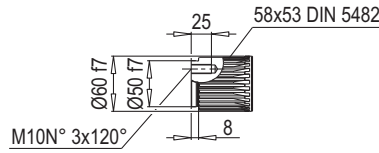

Tahvil Ratio i	Giriş Mili Input Shaft	Çıkış Mili Output Shaft	M ₂ max [Nm]
15.6	1"3/8 Z6	58x53 DIN 5482	10400
17.1			9500
21.4			7800
24.8			6800

* İsteğe bağlı olarak farklı tahvil değerleri yapılabilir.
Different ratio valves could be done upon request.

PYK PL 5002 PS + 52

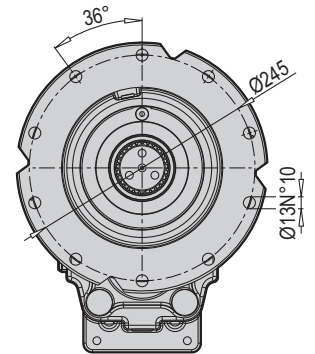
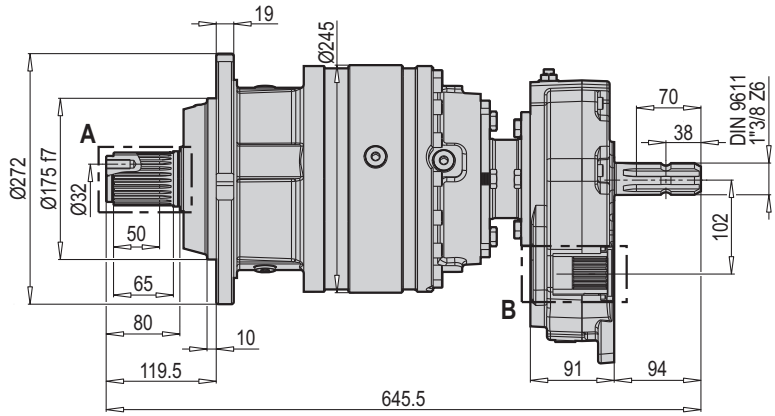
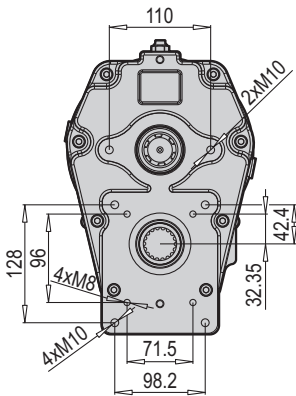

A DETAYI

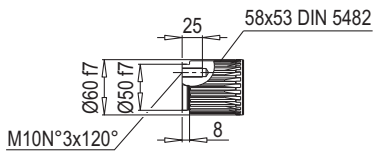

B DETAYI

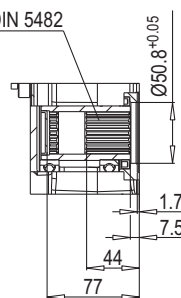

Tahvil Ratio i	Giriş Mili Input Shaft	Çıkış Mili Output Shaft	M ₂ max [Nm]
15.6	1"3/8 Z6	58x53 DIN 5482	10400
17.1			9500
21.4			7800
24.8			6800

* İsteğe bağlı olarak farklı tahvil değerleri yapılabilir.
Different ratio valves could be done upon request.

PYK PL 5002 F

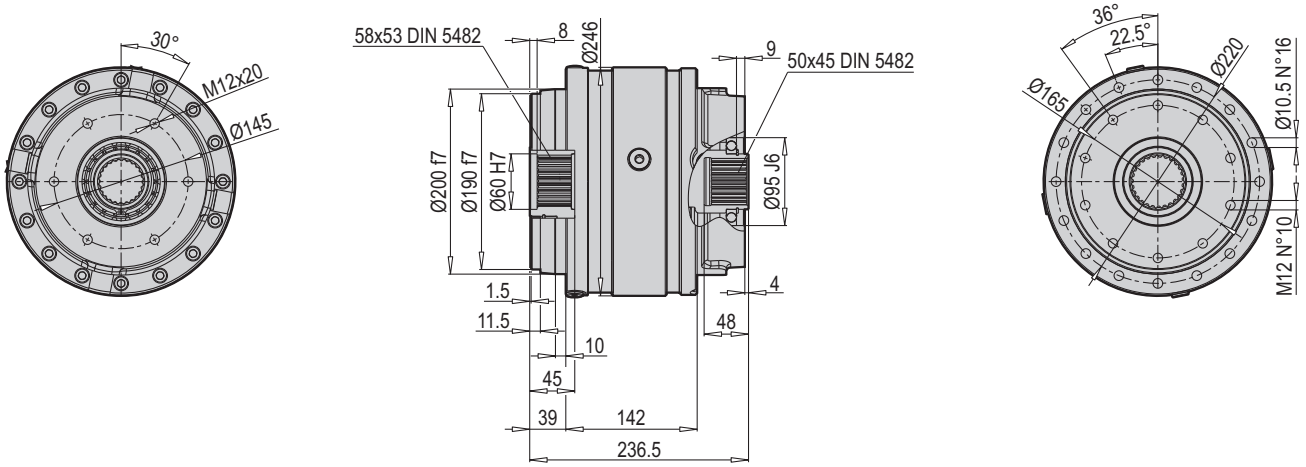

* İsteğe bağlı olarak farklı tahvil değerleri yapılabilir.
Different ratio valves could be done upon request.

Tahvil Ratio i	Giriş Mili Input Shaft	Çıkış Mili Output Shaft	M ₂ max [Nm]
15.6	1"3/8 Z6	58x53 DIN 5482	10400
17.1			9500
21.4			7800
24.8			6800

PYK PL 5002 F + 52

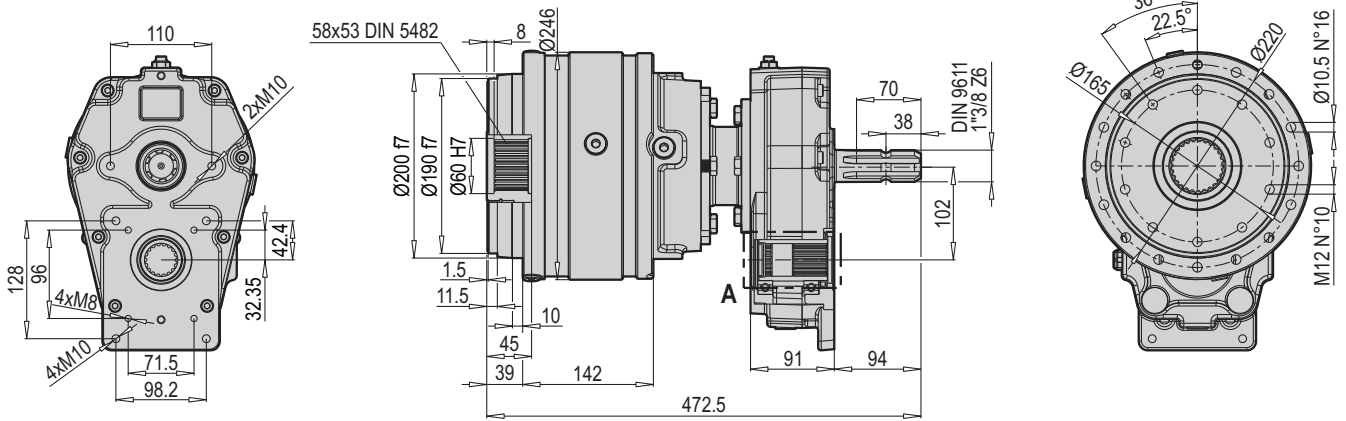

A DETAYI

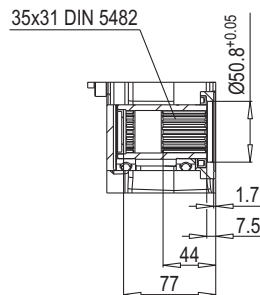

* İsteğe bağlı olarak farklı tahvil değerleri yapılabilir.
Different ratio valves could be done upon request.

Tahvil Ratio i	Giriş Mili Input Shaft	Çıkış Mili Output Shaft	M ₂ max [Nm]
15.6	1"3/8 Z6	58x53 DIN 5482	10400
17.1			9500
21.4			7800
24.8			6800

PYK PL 5002 F + SG

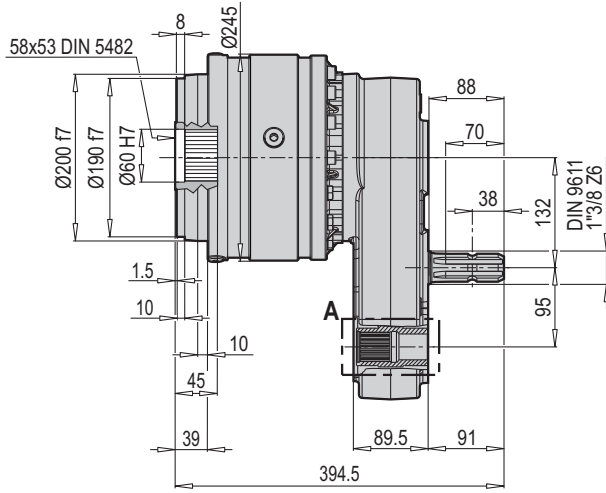

A DETAYI

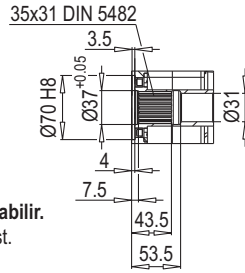

* İsteğe bağlı olarak farklı tahvil değerleri yapılabilir.
Different ratio valves could be done upon request.

Tahvil Ratio i	Giriş Mili Input Shaft	Çıkış Mili Output Shaft	M ₂ max [Nm]
15.6	1"3/8 Z6	58x53 DIN 5482	10400
17.1			9500
21.4			7800
24.8			6800

PYK PL 5002 F + DB

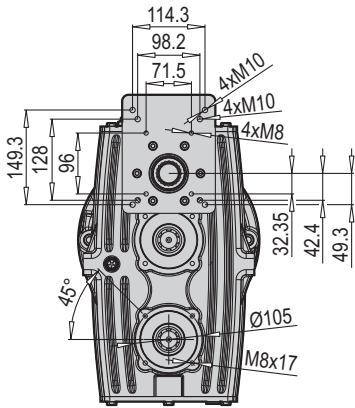

A DETAYI

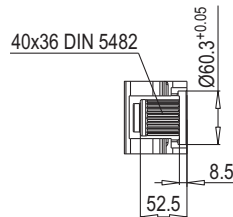

* İsteğe bağlı olarak farklı tahvil değerleri yapılabilir.
Different ratio valves could be done upon request.

Tahvil Ratio i	Giriş Mili Input Shaft	Çıkış Mili Output Shaft	M ₂ max [Nm]
15.6	1"3/8 Z6	58x53 DIN 5482	10400
17.1			9500
21.4			7800
24.8			6800

PYK PL 7002 PS

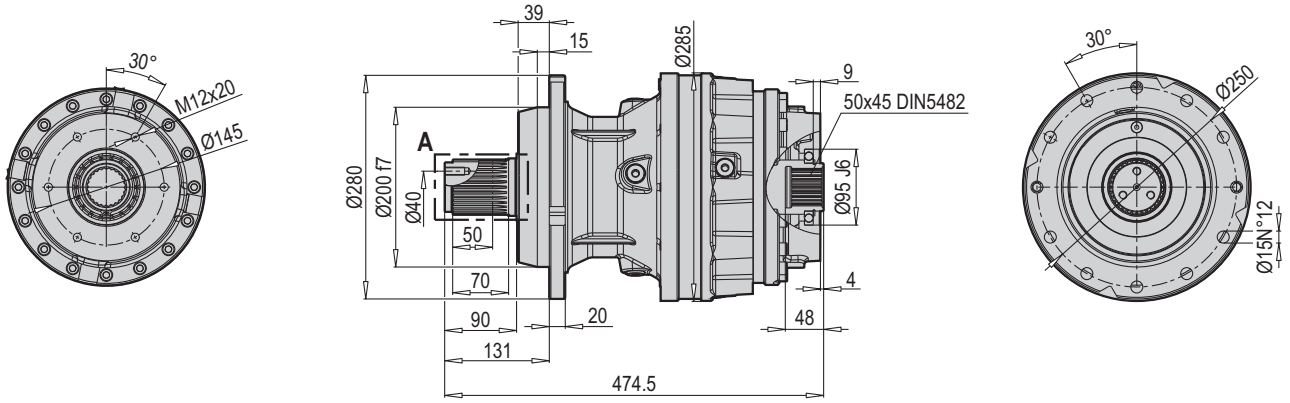

A DETAYI

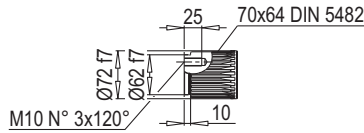

Tahvil Ratio i	Giriş Mili Input Shaft	Çıkış Mili Output Shaft	M ₂ max [Nm]
13.9	1"3/8 Z6	70x64 DIN 5482	14300
15.1			14300
18.3			13000
20.7			11500
24.0			9700

* İsteğe bağlı olarak farklı tahvil değerleri yapılabilir.
Different ratio valves could be done upon request.

PYK PL 7002 PS + 52

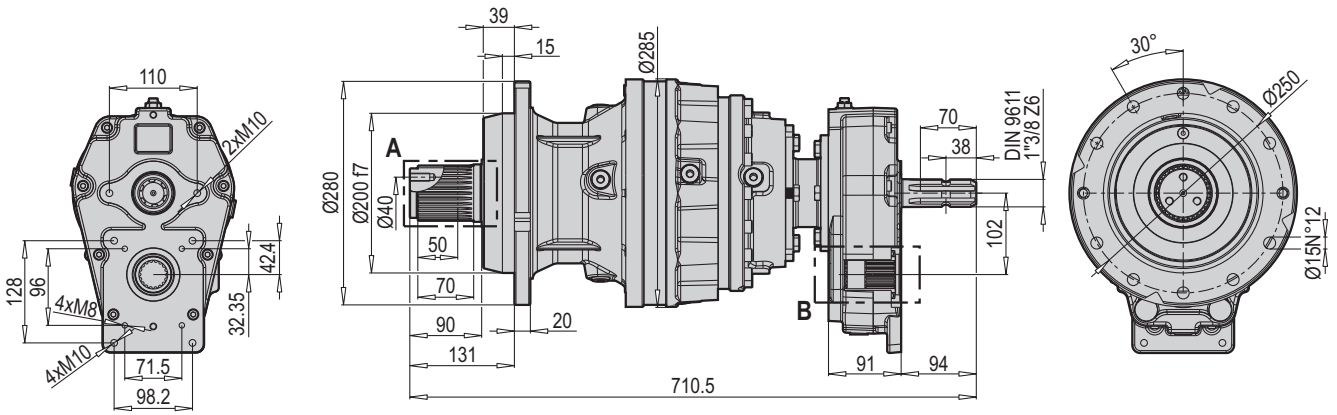

A DETAYI

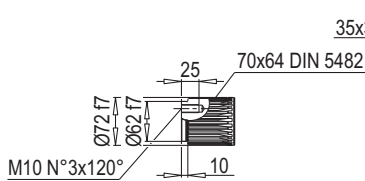

B DETAYI

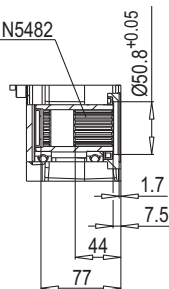

Tahvil Ratio i	Giriş Mili Input Shaft	Çıkış Mili Output Shaft	M ₂ max [Nm]
13.9	1"3/8 Z6	70x64 DIN 5482	14300
15.1			14300
18.3			13000
20.7			11500
24.0			9700

* İsteğe bağlı olarak farklı tahvil değerleri yapılabilir.
Different ratio valves could be done upon request.

PYK PL 7002 F

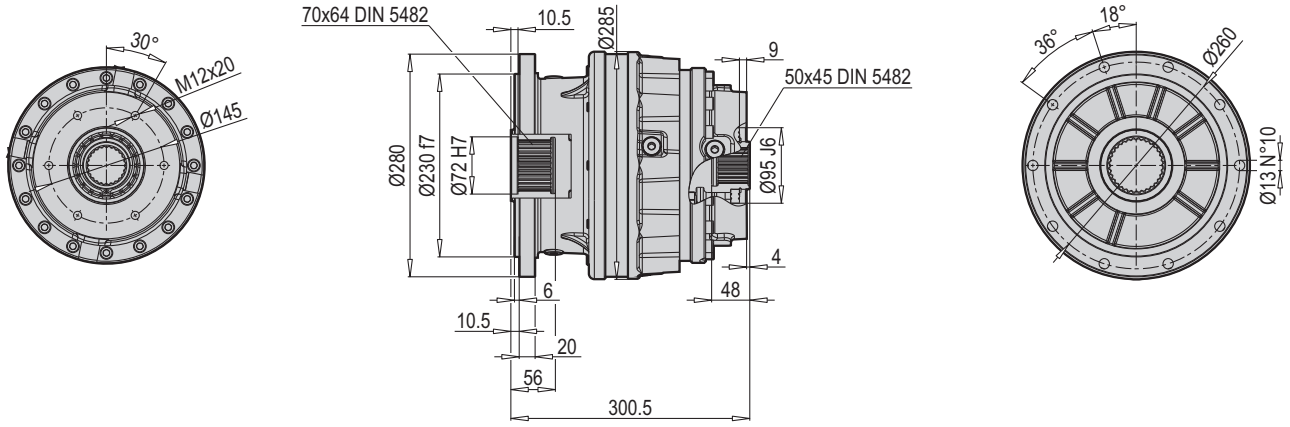

* İsteğe bağlı olarak farklı tahvil değerleri yapılabilir.
Different ratio valves could be done upon request.

Tahvil Ratio i	Giriş Mili Input Shaft	Çıkış Mili Output Shaft	M ₂ max [Nm]
13.9	1"3/8 Z6	70x64 DIN 5482	14300
15.1			14300
18.3			13000
20.7			11500
24.0			9700

PYK PL 7002 F + 52

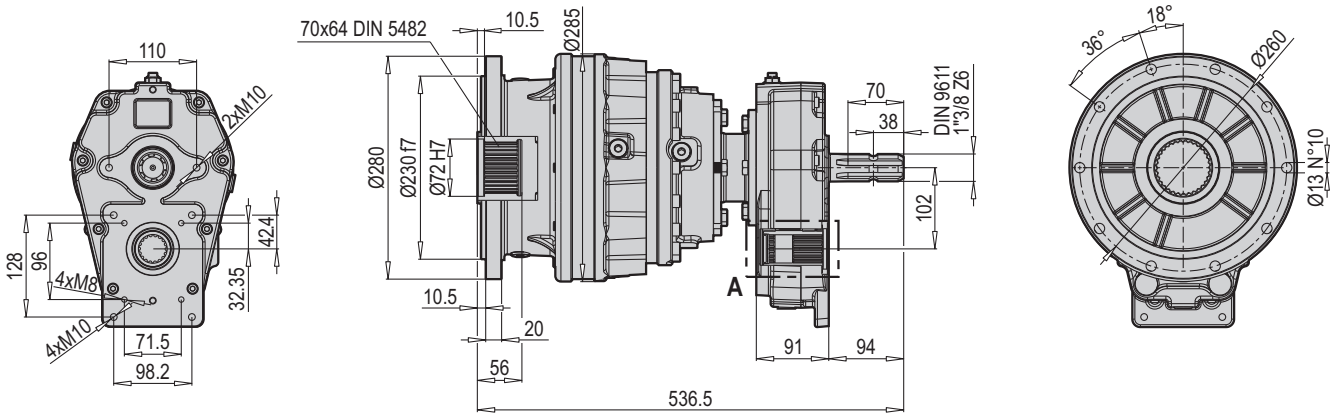

A DETAYI

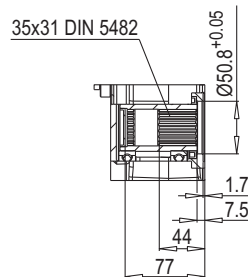

* İsteğe bağlı olarak farklı tahvil değerleri yapılabilir.
Different ratio valves could be done upon request.

Tahvil Ratio i	Giriş Mili Input Shaft	Çıkış Mili Output Shaft	M ₂ max [Nm]
13.9	1"3/8 Z6	70x64 DIN 5482	14300
15.1			14300
18.3			13000
20.7			11500
24.0			9700

PYK PL 10002 MS

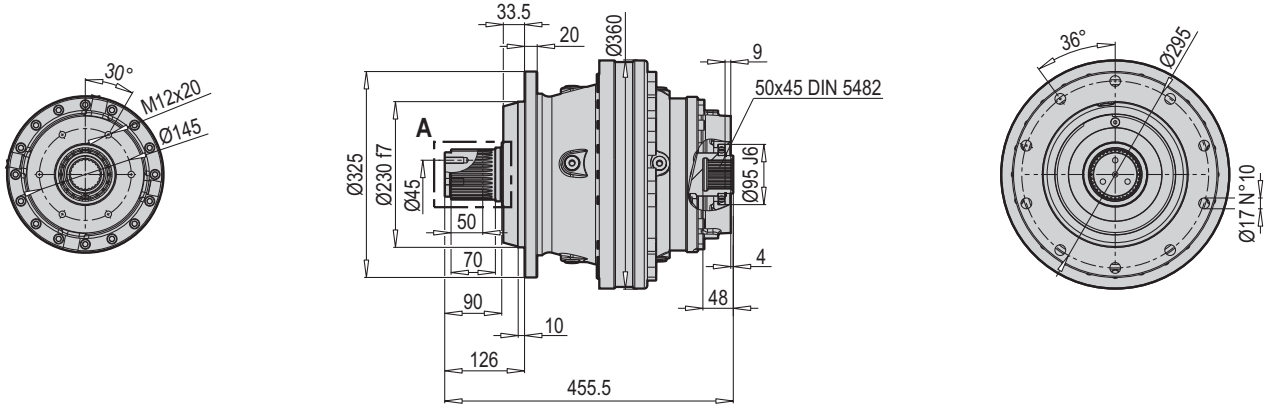

A DETAYI

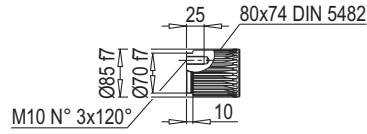

Tahvil Ratio i	Giriş Mili Input Shaft	Çıkış Mili Output Shaft	M ₂ max [Nm]
13.4	1"3/8 Z6	80x74 DIN 5482	24900
16.2			21400
18.4			24900
22.1			21400
25.7			21400

* İsteğe bağlı olarak farklı tahvil değerleri yapılabilir.
Different ratio valves could be done upon request.

PYK PL 10002 MS + 52

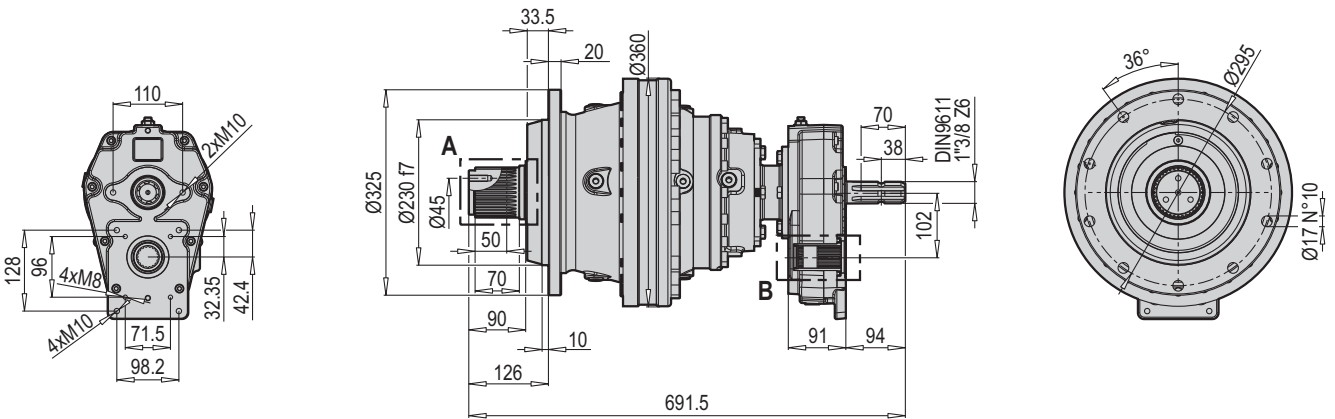

A DETAYI

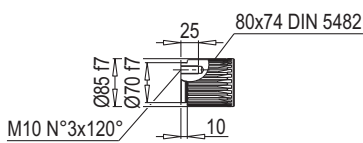

B DETAYI

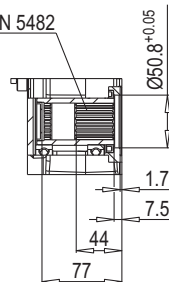

Tahvil Ratio i	Giriş Mili Input Shaft	Çıkış Mili Output Shaft	M ₂ max [Nm]
13.4	1"3/8 Z6	80x74 DIN 5482	24900
16.2			21400
18.4			24900
22.1			21400
25.7			21400

* İsteğe bağlı olarak farklı tahvil değerleri yapılabilir.
Different ratio valves could be done upon request.

PYK PL 10002 MS + SG

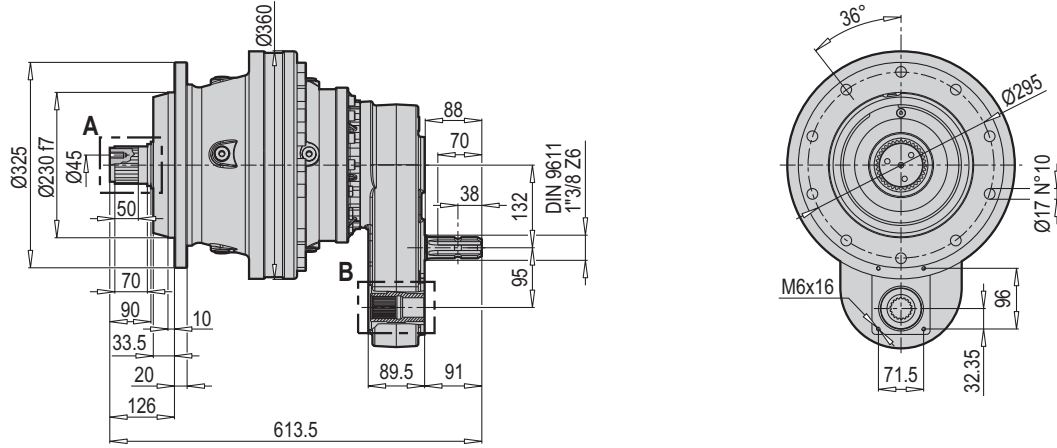

A DETAYI

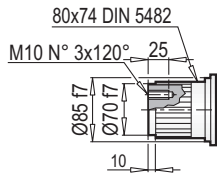

B DETAYI

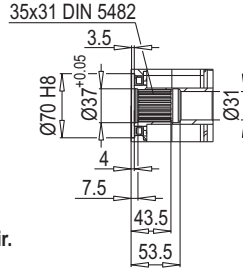

* İsteğe bağlı olarak farklı tahvil değerleri yapılabilir.
Different ratio valves could be done upon request.

Tahvil Ratio i	Giriş Mili Input Shaft	Çıkış Mili Output Shaft	M ₂ max [Nm]
13.4	1"3/8 Z6	80x74 DIN 5482	24900
16.2			21400
18.4			24900
22.1			21400
25.7			21400

PYK PL 10002 MS + DB

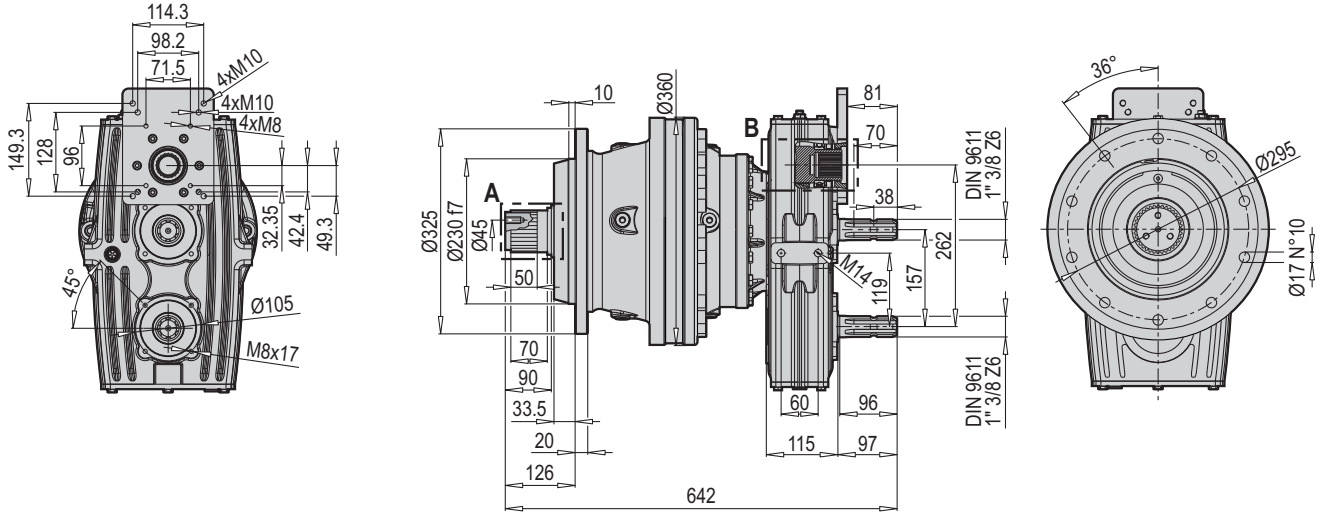

A DETAYI

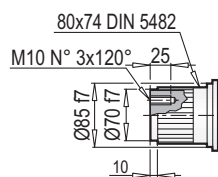

B DETAYI

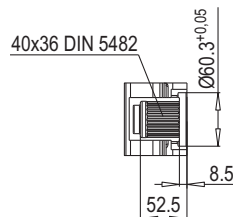

* İsteğe bağlı olarak farklı tahvil değerleri yapılabilir.
Different ratio valves could be done upon request.

Tahvil Ratio i	Giriş Mili Input Shaft	Çıkış Mili Output Shaft	M ₂ max [Nm]
13.4	1"3/8 Z6	80x74 DIN 5482	24900
16.2			21400
18.4			24900
22.1			21400
25.7			21400

PYK PL 10002 F

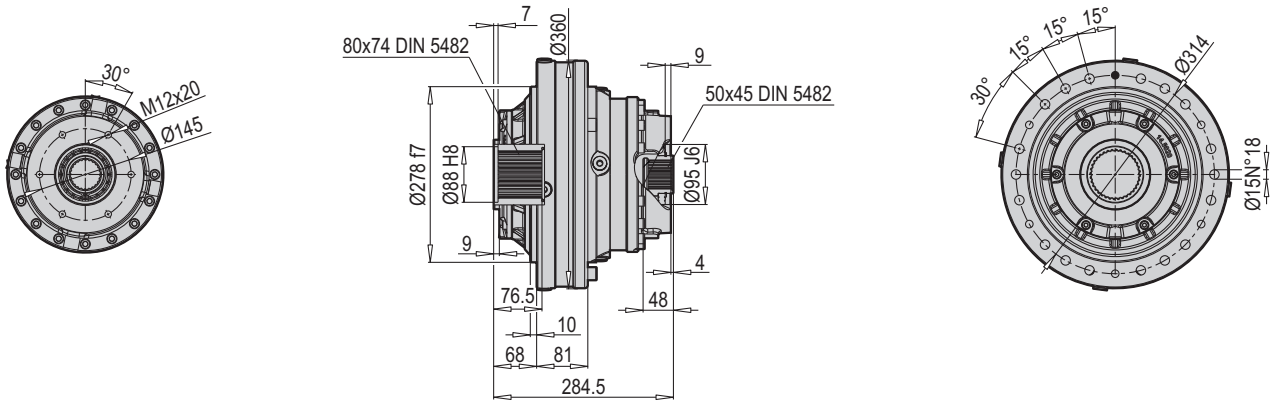

* İsteğe bağlı olarak farklı tahvil değerleri yapılabilir.
Different ratio valves could be done upon request.

Tahvil Ratio i	Giriş Mili Input Shaft	Çıkış Mili Output Shaft	M ₂ max [Nm]
13.4	1"3/8 Z6	80x74 DIN 5482	24900
16.2			21400
18.4			24900
22.1			21400
25.7			21400

PYK PL 10002 F + 52

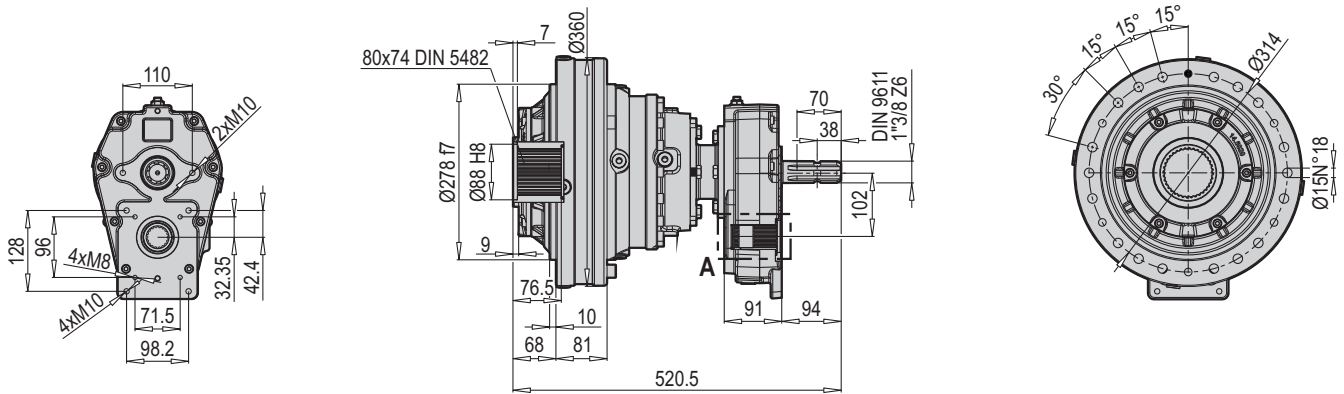

A DETAYI

* İsteğe bağlı olarak farklı tahvil değerleri yapılabilir.
Different ratio valves could be done upon request.

Tahvil Ratio i	Giriş Mili Input Shaft	Çıkış Mili Output Shaft	M ₂ max [Nm]
13.4	1"3/8 Z6	80x74 DIN 5482	24900
16.2			21400
18.4			24900
22.1			21400
25.7			21400

PYK PL 1002 F + SG

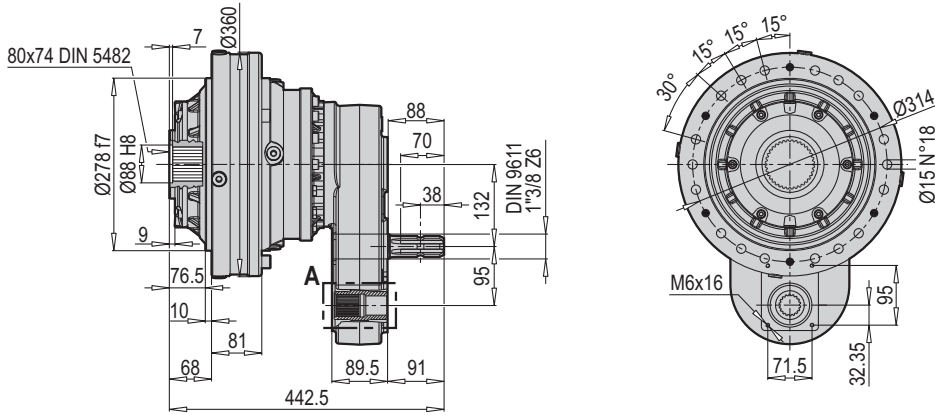

A DETAYI

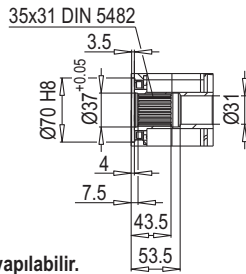

* İsteğe bağlı olarak farklı tahvil değerleri yapılabilir.
Different ratio valves could be done upon request.

Tahvil Ratio i	Giriş Mili Input Shaft	Çıkış Mili Output Shaft	M ₂ max [Nm]
13.4	1"3/8 Z6	80x74 DIN 5482	24900
16.2			21400
18.4			24900
22.1			21400
25.7			21400

PYK PL 1002 F + DB

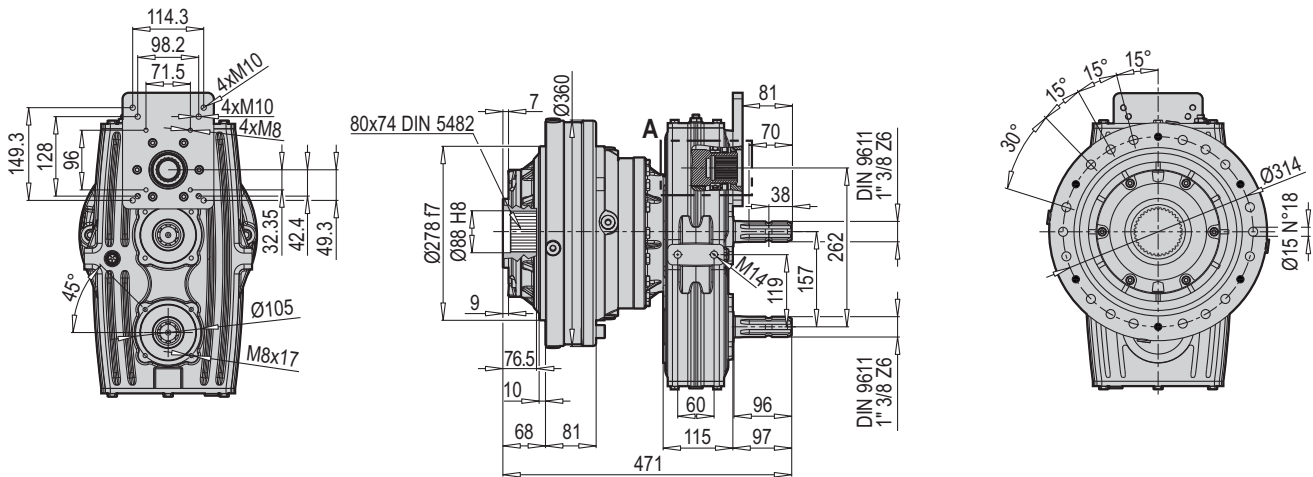

A DETAYI

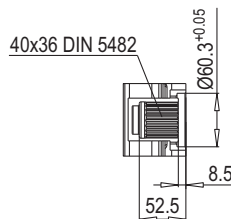

* İsteğe bağlı olarak farklı tahvil değerleri yapılabilir.
Different ratio valves could be done upon request.

Tahvil Ratio i	Giriş Mili Input Shaft	Çıkış Mili Output Shaft	M ₂ max [Nm]
13.4	1"3/8 Z6	80x74 DIN 5482	24900
16.2			21400
18.4			24900
22.1			21400
25.7			21400

PYK PL 16002 MS

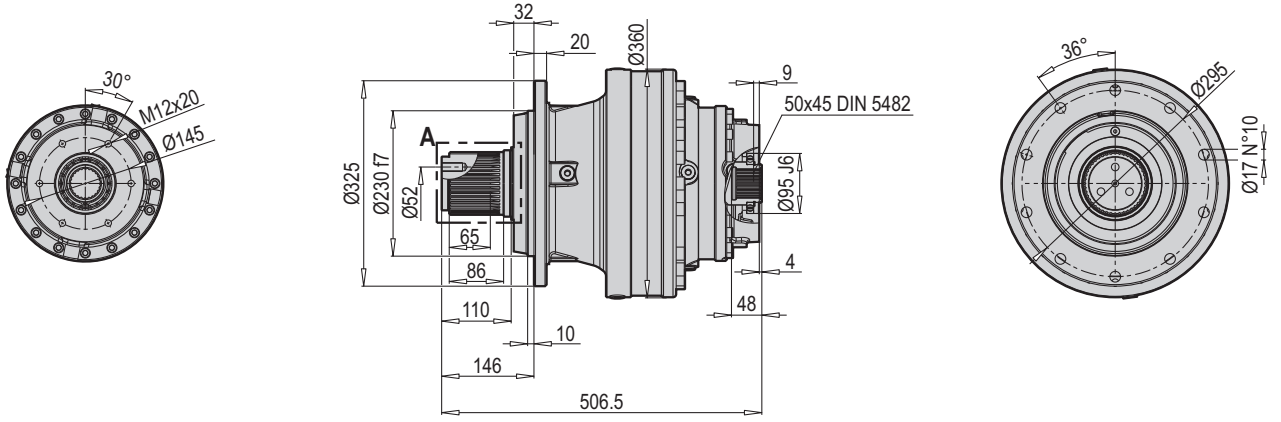

A DETAYI

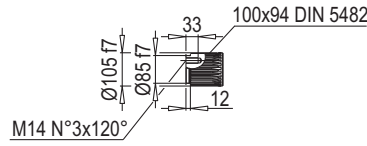

* İsteğe bağlı olarak farklı tahvil değerleri yapılabilir.
Different ratio valves could be done upon request.

Tahvil Ratio i	Giriş Mili Input Shaft	Çıkış Mili Output Shaft	M ₂ max [Nm]
13.4	1"3/8 Z6	100x74 DIN 5482	36700
16.2			32000
22.1			32000
28.9			24500
33.6			24500

PYK PL 16002 MS + 52

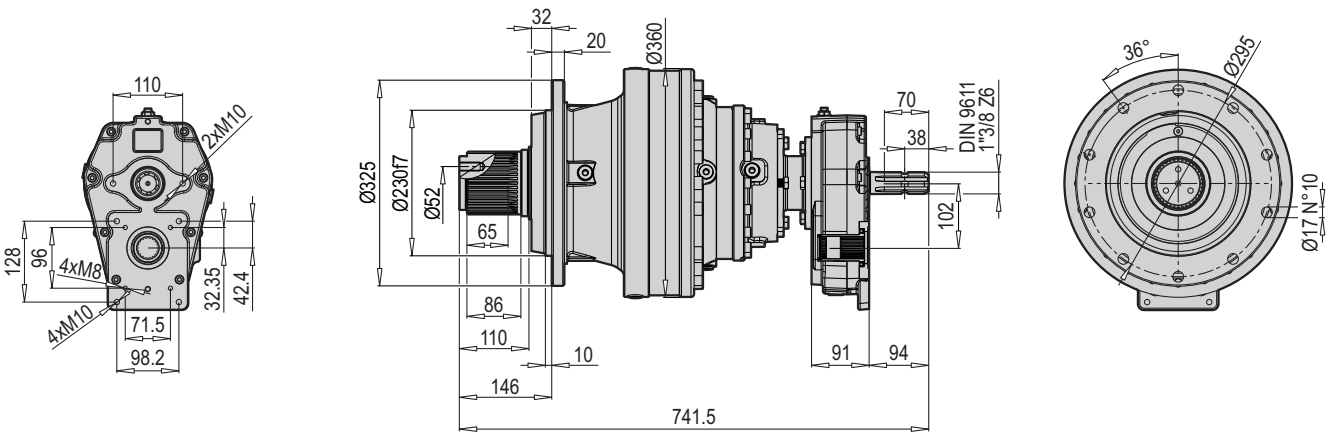

A DETAYI

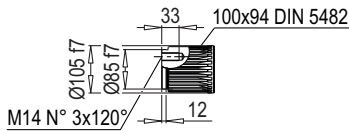

B DETAYI

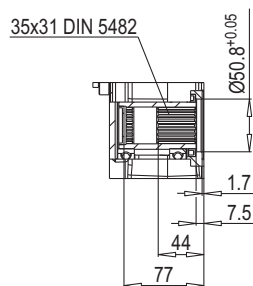

* İsteğe bağlı olarak farklı tahvil değerleri yapılabilir.
Different ratio valves could be done upon request.

Tahvil Ratio i	Giriş Mili Input Shaft	Çıkış Mili Output Shaft	M ₂ max [Nm]
13.4	1"3/8 Z6	100x74 DIN 5482	36700
16.2			32000
22.1			32000
28.9			24500
33.6			24500

PYK PL 16002 MS + SG

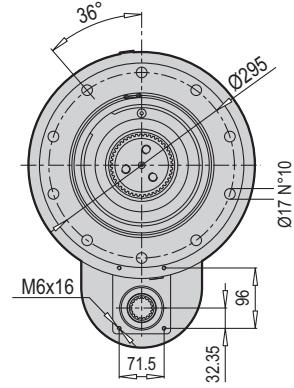
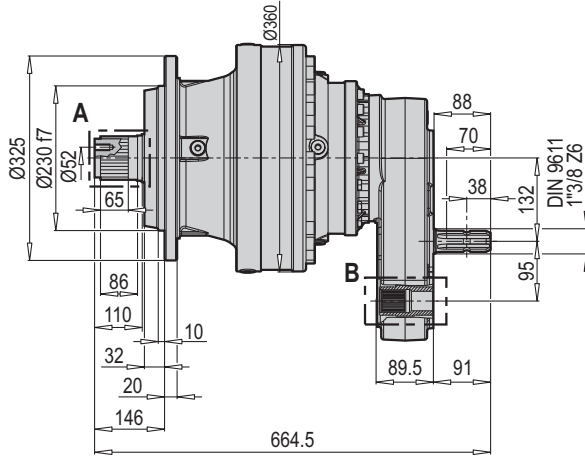

A DETAYI

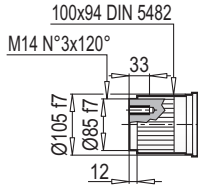

B DETAYI

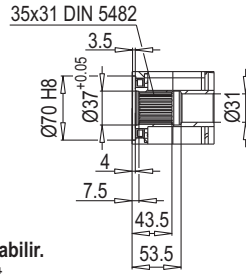

* İsteğe bağlı olarak farklı tahvil değerleri yapılabilir.
Different ratio valves could be done upon request.

Tahvil Ratio i	Giriş Mili Input Shaft	Çıkış Mili Output Shaft	M ₂ max [Nm]
13.4			36700
16.2			32000
22.1	1"3/8 Z6	100x94 DIN 5482	32000
28.9			24500
33.6			24500

PYK PL 16002 MS + DB

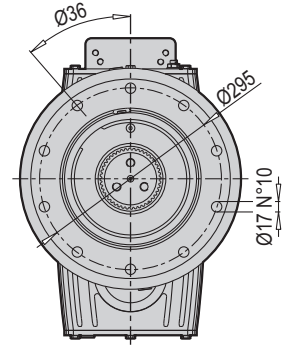
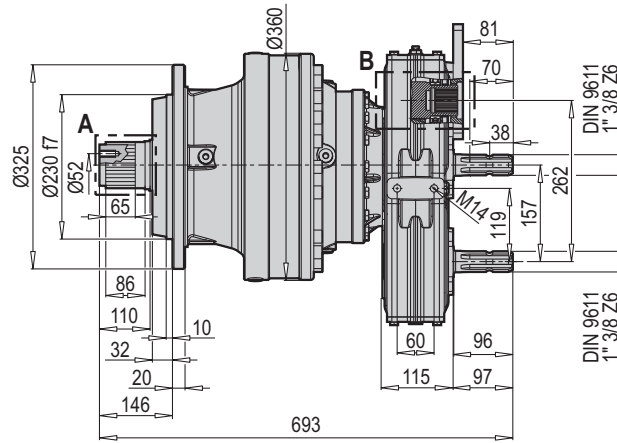
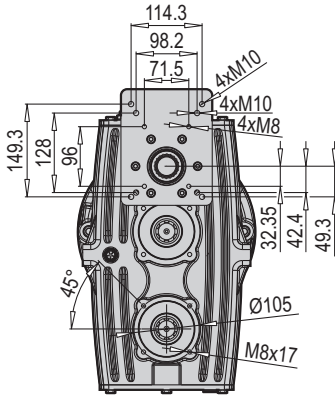

A DETAYI

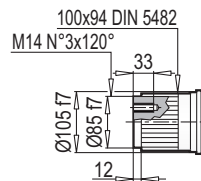

B DETAYI

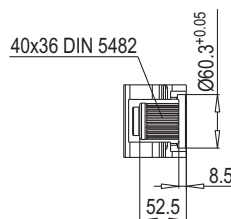

* İsteğe bağlı olarak farklı tahvil değerleri yapılabilir.
Different ratio valves could be done upon request.

Tahvil Ratio i	Giriş Mili Input Shaft	Çıkış Mili Output Shaft	M ₂ max [Nm]
13.4			36700
16.2			32000
22.1	1"3/8 Z6	100x94 DIN 5482	32000
28.9			24500
33.6			24500

PYK PL 16002 F

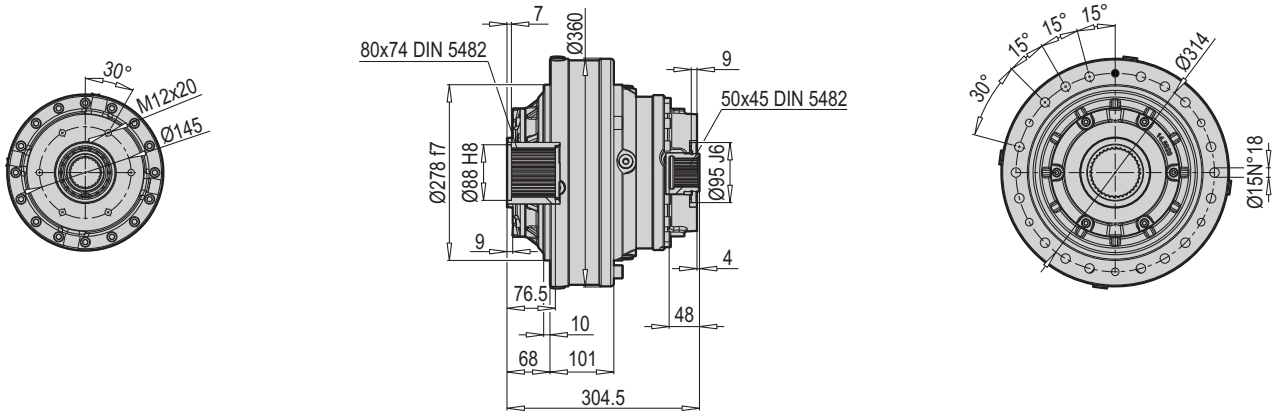

* İsteğe bağlı olarak farklı tahvil değerleri yapılabilir.
Different ratio valves could be done upon request.

Tahvil Ratio i	Giriş Mili Input Shaft	Çıkış Mili Output Shaft	M_2 max [Nm]
13.4	1"3/8 Z6	80x74 DIN 5482	36700
16.2			32000
22.1			32000
28.9			24500
33.6			24500

PYK PL 16002 F + 52

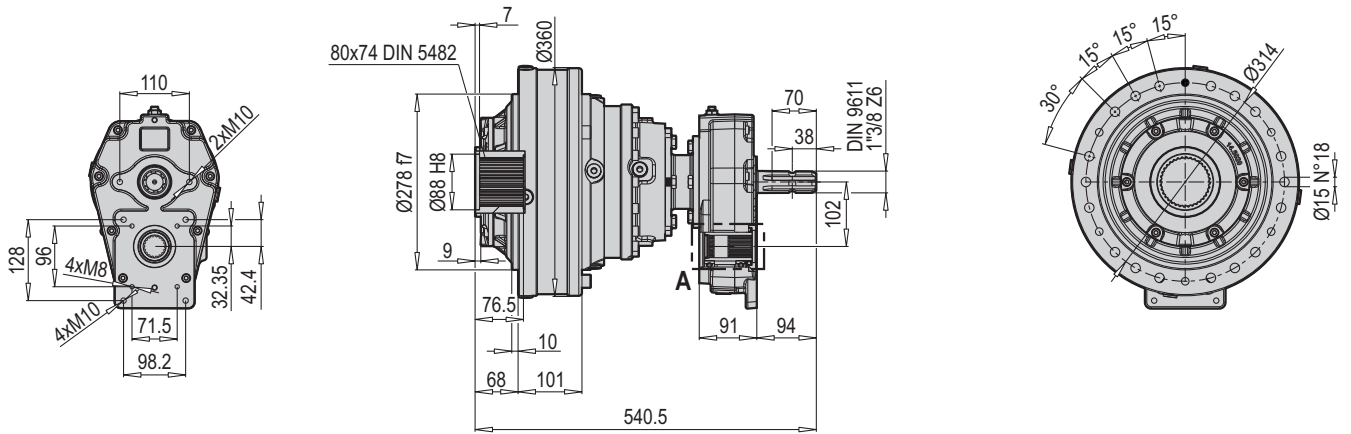

* İsteğe bağlı olarak farklı tahvil değerleri yapılabilir.
Different ratio valves could be done upon request.

Tahvil Ratio i	Giriş Mili Input Shaft	Çıkış Mili Output Shaft	M_2 max [Nm]
13.4	1"3/8 Z6	80x74 DIN 5482	36700
16.2			32000
22.1			32000
28.9			24500
33.6			24500

PYK PL 18002 MS

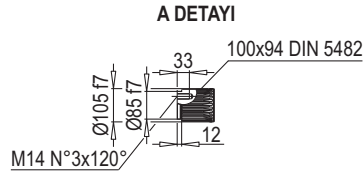
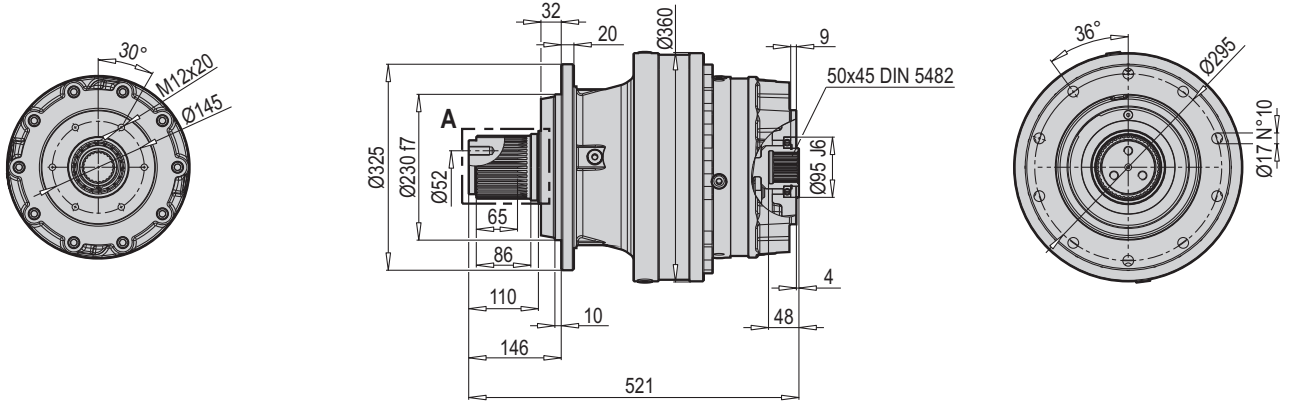

Tahvil Ratio i	Giriş Mili Input Shaft	Çıkış Mili Output Shaft	M ₂ max [Nm]
15.7	1"3/8 Z6	100x94 DIN 5482	36700
19.0			32000
21.4			32000
24.9			32000
30.0			32000

* İsteğe bağlı olarak farklı tahvil değerleri yapılabilir.
Different ratio valves could be done upon request.

PYK PL 18002 MS + 52

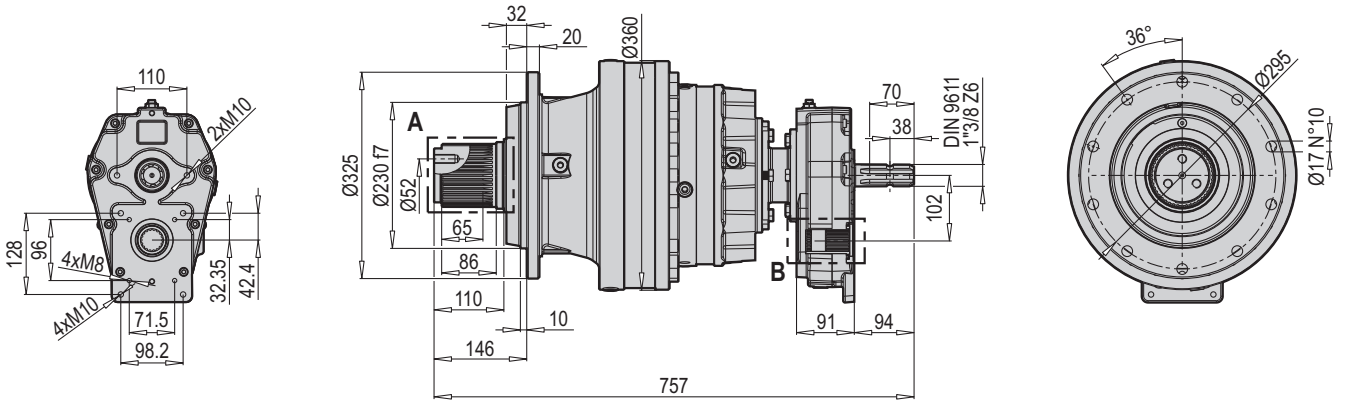

A DETAYI

B DETAYI

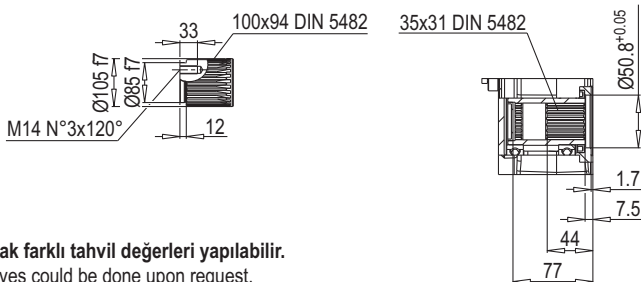

Tahvil Ratio i	Giriş Mili Input Shaft	Çıkış Mili Output Shaft	M ₂ max [Nm]
15.7	1"3/8 Z6	100x94 DIN 5482	36700
19.0			32000
21.4			32000
24.9			32000
30.0			32000

* İsteğe bağlı olarak farklı tahvil değerleri yapılabilir.
Different ratio valves could be done upon request.

PYK PL 18002 MS + SG

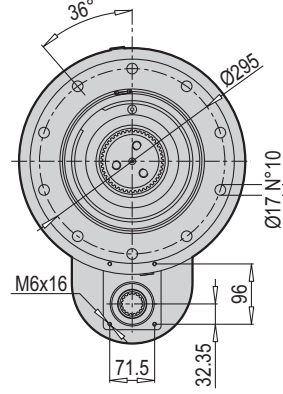
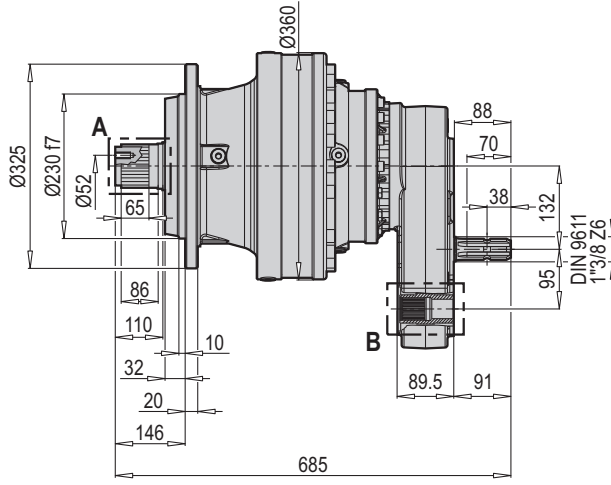

A DETAYI

B DETAYI

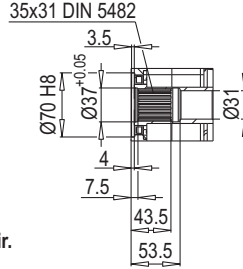
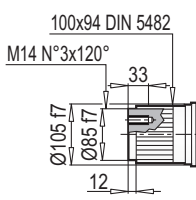

* İsteğe bağlı olarak farklı tahvil değerleri yapılabilir.
Different ratio valves could be done upon request.

Tahvil Ratio i	Giriş Mili Input Shaft	Çıkış Mili Output Shaft	M ₂ max [Nm]
15.7	1"3/8 Z6	100x94 DIN 5482	36700
19.0			32000
21.4			32000
24.9			32000
30.0			32000

PYK PL 18002 MS + DB

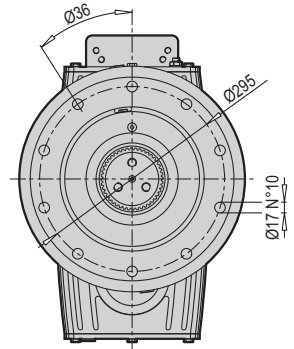
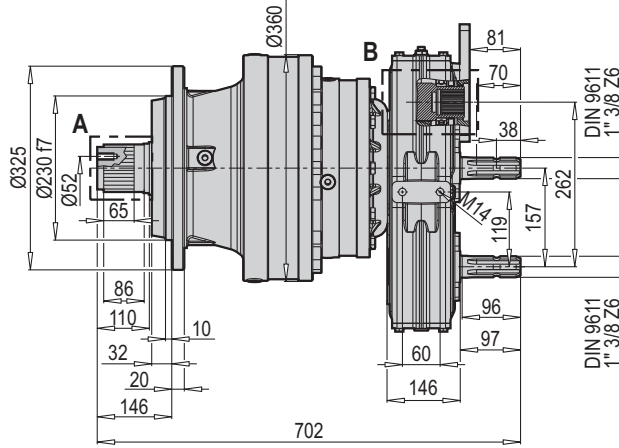
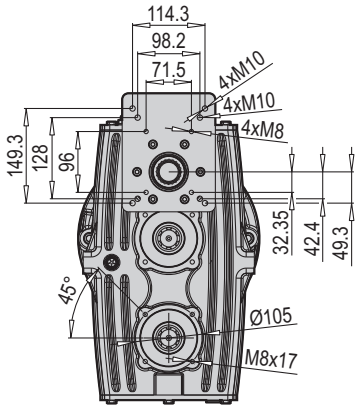

A DETAYI

B DETAYI

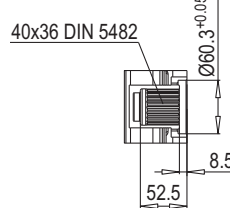
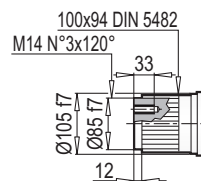

* İsteğe bağlı olarak farklı tahvil değerleri yapılabilir.
Different ratio valves could be done upon request.

Tahvil Ratio i	Giriş Mili Input Shaft	Çıkış Mili Output Shaft	M ₂ max [Nm]
15.7	1"3/8 Z6	100x94 DIN 5482	36700
19.0			32000
21.4			32000
24.9			32000
30.0			32000

PYK PL 18002 F

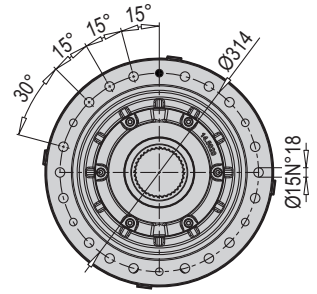
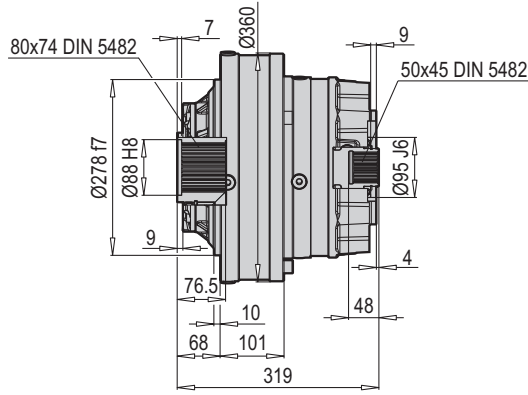
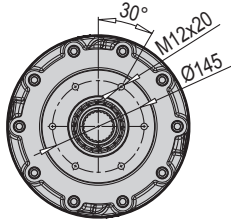

* İsteğe bağlı olarak farklı tahvil değerleri yapılabilir.
Different ratio valves could be done upon request.

Tahvil Ratio i	Giriş Mili Input Shaft	Çıkış Mili Output Shaft	M ₂ max [Nm]
15.7	1"3/8 Z6	80x74 DIN 5482	36700
19.0			32000
21.4			32000
24.9			32000
30.0			32000

PYK PL 18002 F + 52

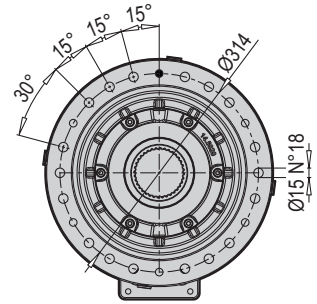
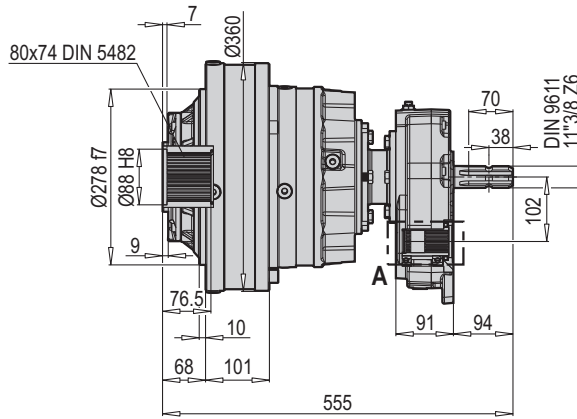
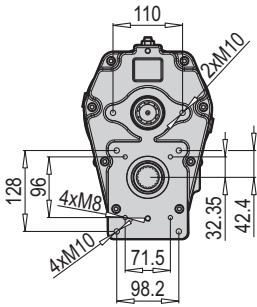

A DETAYI

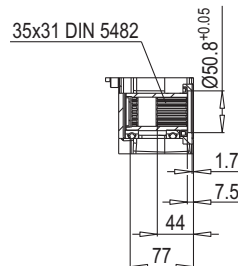

* İsteğe bağlı olarak farklı tahvil değerleri yapılabilir.
Different ratio valves could be done upon request.

Tahvil Ratio i	Giriş Mili Input Shaft	Çıkış Mili Output Shaft	M ₂ max [Nm]
15.7	1"3/8 Z6	80x74 DIN 5482	36700
19.0			32000
21.4			32000
24.9			32000
30.0			32000

PYK PL 18002 F + SG

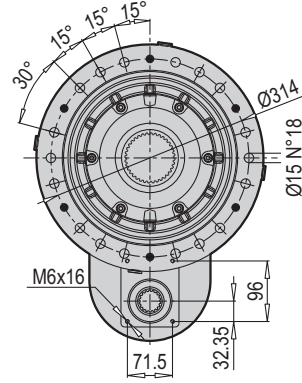
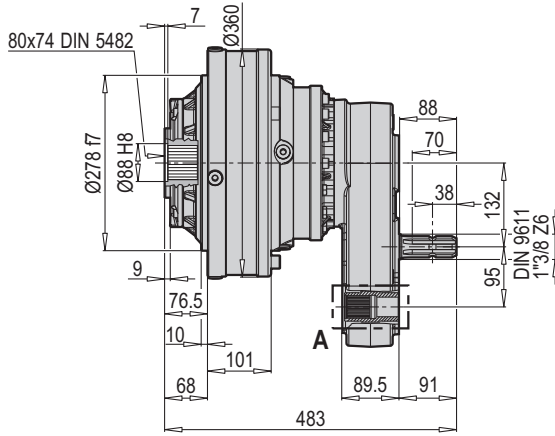

A DETAYI

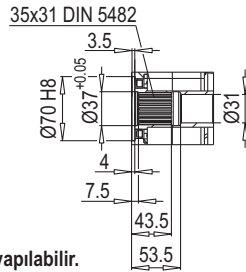

* İsteğe bağlı olarak farklı tahvil değerleri yapılabilir.
Different ratio valves could be done upon request.

Tahvil Ratio i	Giriş Mili Input Shaft	Çıkış Mili Output Shaft	M ₂ max [Nm]
15.7	1"3/8 Z6	80x74 DIN 5482	36700
19.0			32000
21.4			32000
24.9			32000
30.0			32000

PYK PL 18002 F + DB

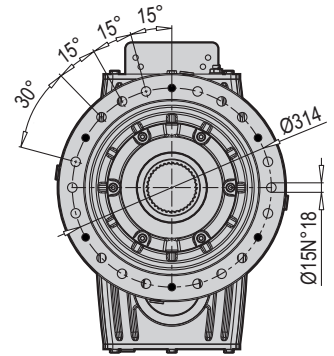
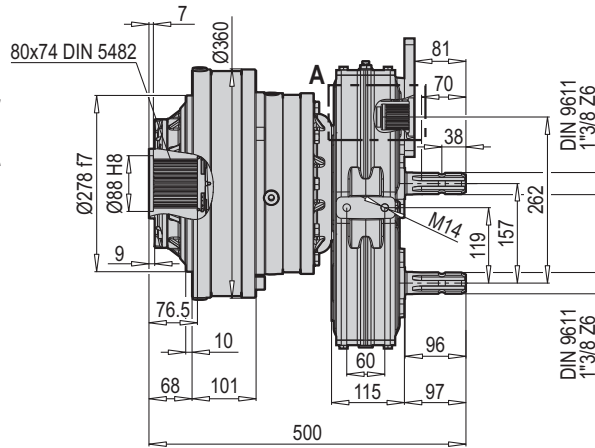
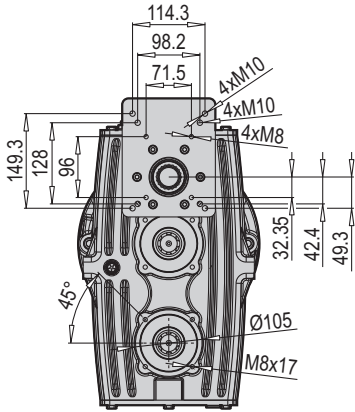

A DETAYI

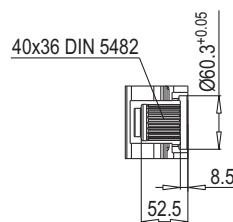

* İsteğe bağlı olarak farklı tahvil değerleri yapılabilir.
Different ratio valves could be done upon request.

Tahvil Ratio i	Giriş Mili Input Shaft	Çıkış Mili Output Shaft	M ₂ max [Nm]
15.7	1"3/8 Z6	80x74 DIN 5482	36700
19.0			32000
21.4			32000
24.9			32000
30.0			32000

PYK PL 25002 MS

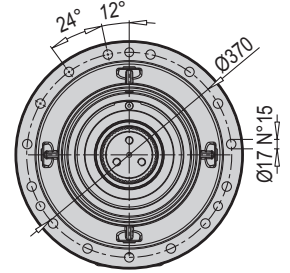
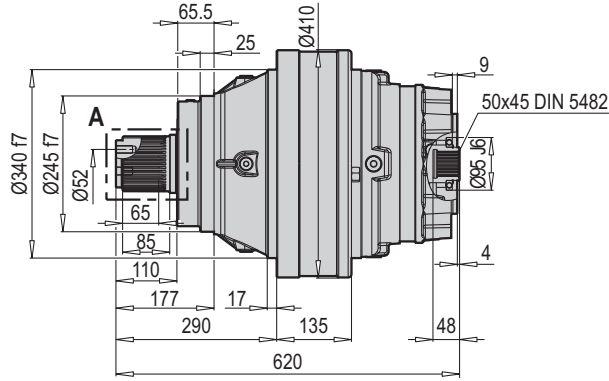
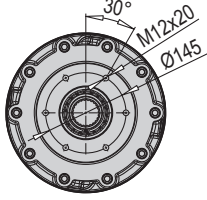

A DETAYI

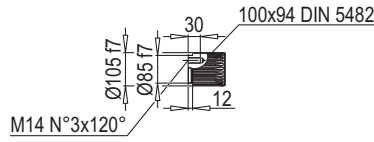

Tahvil Ratio i	Giriş Mili Input Shaft	Çıkış Mili Output Shaft	M ₂ max [Nm]
14.7	1"3/8 Z6	100x94 DIN 5482	62700
20.0			62700
26.0			48500
30.2			48500
36.3			37500

* İsteğe bağlı olarak farklı tahvil değerleri yapılabilir.
Different ratio valves could be done upon request.

PYK PL 25002 MS + 52

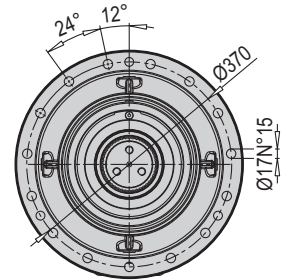
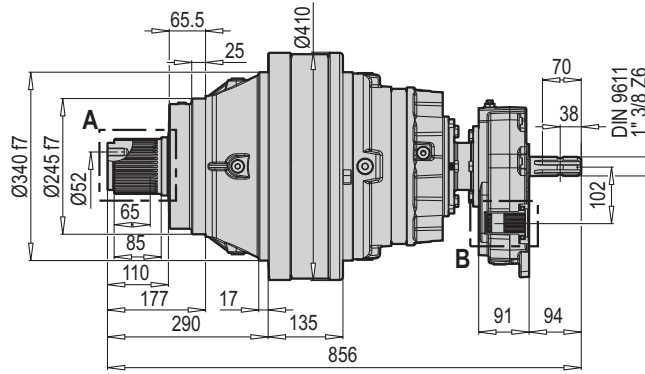
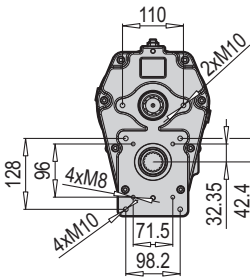

A DETAYI

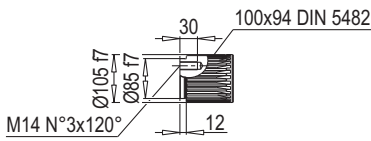

B DETAYI

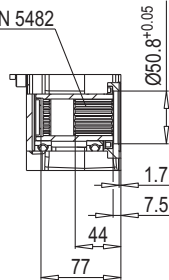

Tahvil Ratio i	Giriş Mili Input Shaft	Çıkış Mili Output Shaft	M ₂ max [Nm]
14.7	1"3/8 Z6	100x94 DIN 5482	62700
20.0			62700
26.0			48500
30.2			48500
36.3			37500

* İsteğe bağlı olarak farklı tahvil değerleri yapılabilir.
Different ratio valves could be done upon request.

PYK PL 25002 F

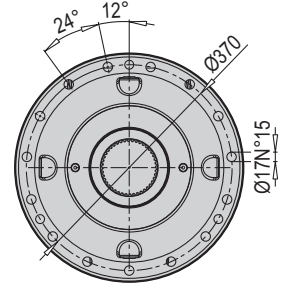
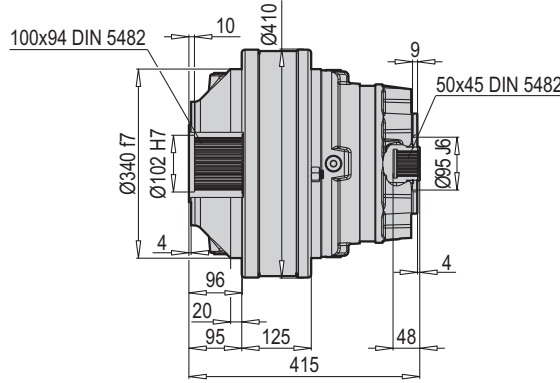
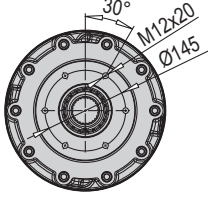

* İsteğe bağlı olarak farklı tahvil değerleri yapılabilir.
Different ratio valves could be done upon request.

Tahvil Ratio i	Giriş Mili Input Shaft	Çıkış Mili Output Shaft	M_2 max [Nm]
14.7	1"3/8 Z6	100x94 DIN 5482	62700
20.0			62700
26.0			48500
30.2			48500
36.3			37500

PYK PL 25002 F + 52

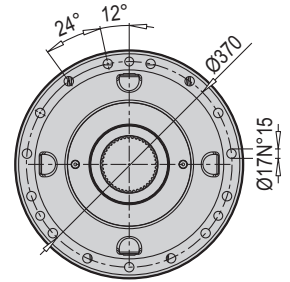
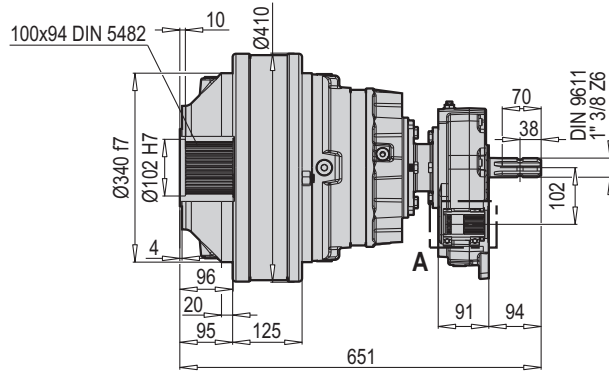
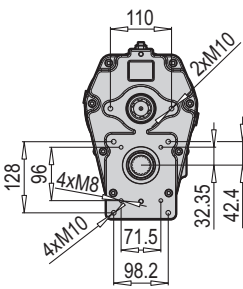

A DETAYI

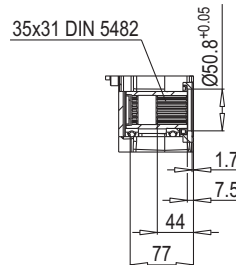

* İsteğe bağlı olarak farklı tahvil değerleri yapılabilir.
Different ratio valves could be done upon request.

Tahvil Ratio i	Giriş Mili Input Shaft	Çıkış Mili Output Shaft	M_2 max [Nm]
14.7	1"3/8 Z6	100x94 DIN 5482	62700
20.0			62700
26.0			48500
30.2			48500
36.3			37500

PYK PL 25002 F + SG

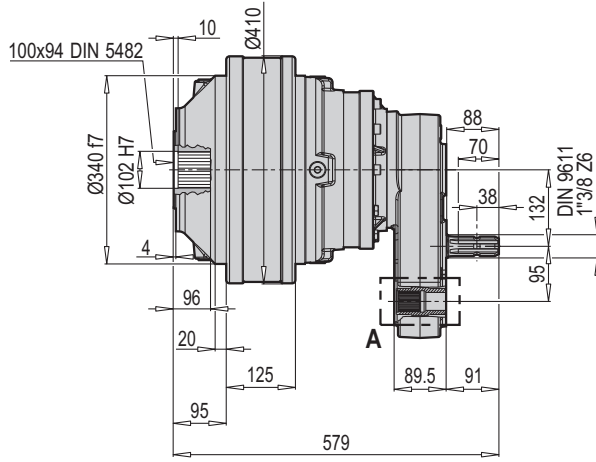

A DETAYI

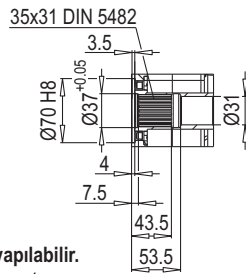

* İsteğe bağlı olarak farklı tahvil değerleri yapılabilir.
Different ratio valves could be done upon request.

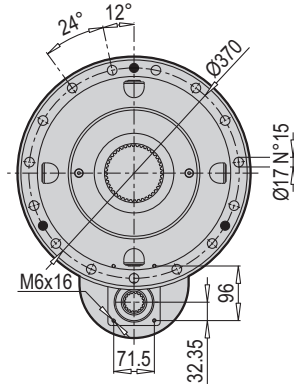

Tahvil Ratio i	Giriş Mili Input Shaft	Çıkış Mili Output Shaft	M ₂ max [Nm]
14.7	1"3/8 Z6	100x94 DIN 5482	62700
20.0			62700
26.0			48500
30.2			48500
36.3			37500

PYK PL 25002 F + DB

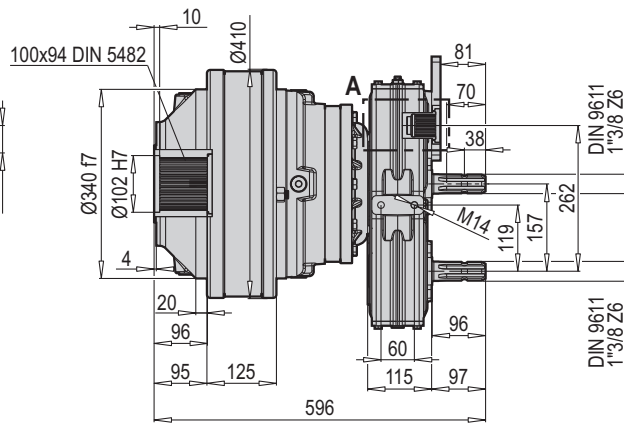
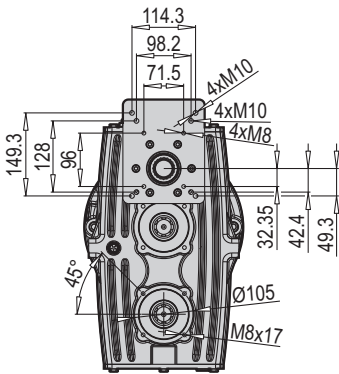

A DETAYI

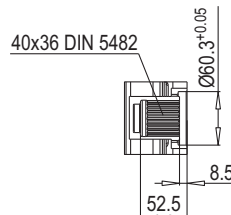

* İsteğe bağlı olarak farklı tahvil değerleri yapılabilir.
Different ratio valves could be done upon request.

Tahvil Ratio i	Giriş Mili Input Shaft	Çıkış Mili Output Shaft	M ₂ max [Nm]
14.7	1"3/8 Z6	100x94 DIN 5482	62700
20.0			62700
26.0			48500
30.2			48500
36.3			37500

PYK PL 30002 F

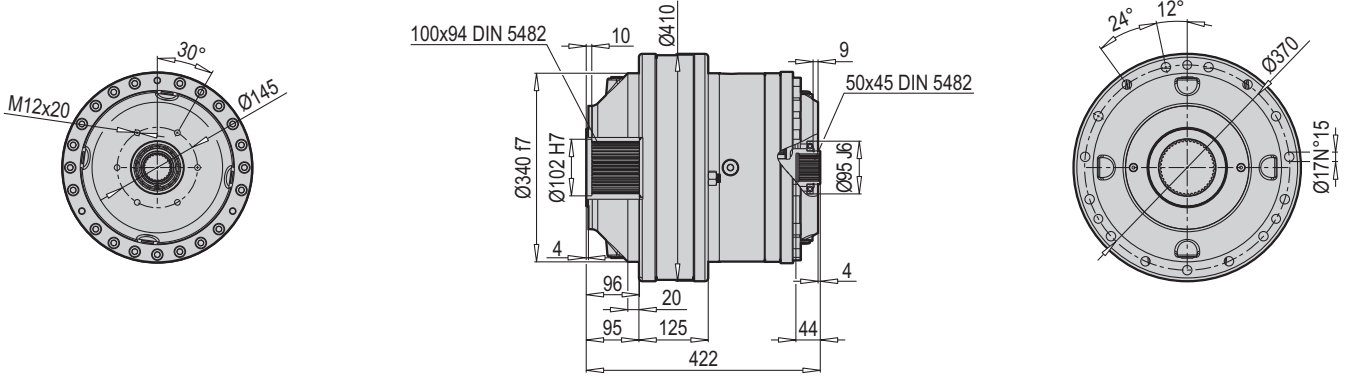

* İsteğe bağlı olarak farklı tahvil değerleri yapılabilir.
Different ratio valves could be done upon request.

Tahvil Ratio i	Giriş Mili Input Shaft	Çıkış Mili Output Shaft	M ₂ max [Nm]
34.7			62700
45.1	1"3/8 Z6	100x94 DIN 5482	48500
54.2			37500

PYK PL 30002 F + 52

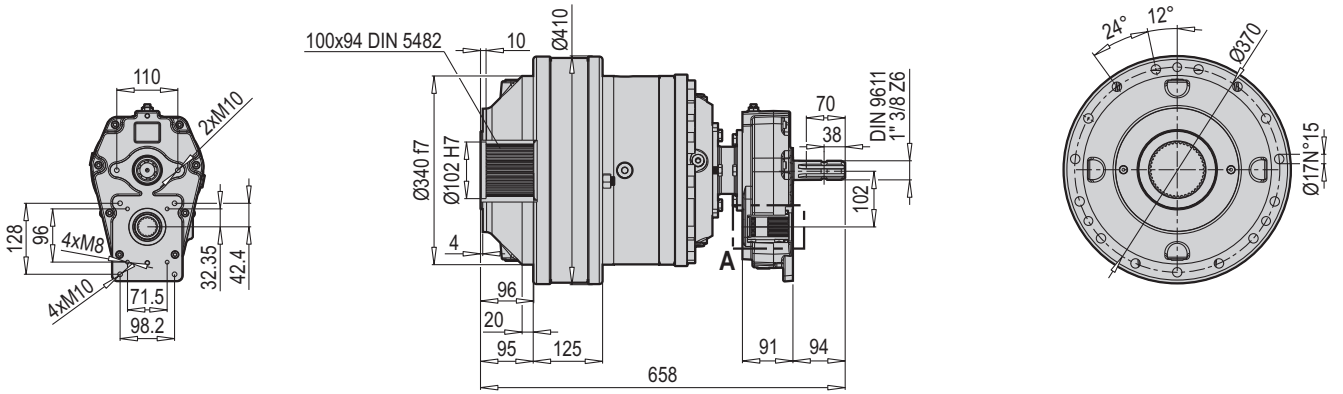

* İsteğe bağlı olarak farklı tahvil değerleri yapılabilir.
Different ratio valves could be done upon request.

Tahvil Ratio i	Giriş Mili Input Shaft	Çıkış Mili Output Shaft	M ₂ max [Nm]
34.7			62700
45.1	1"3/8 Z6	100x94 DIN 5482	48500
54.2			37500

PYK PL 35003 F

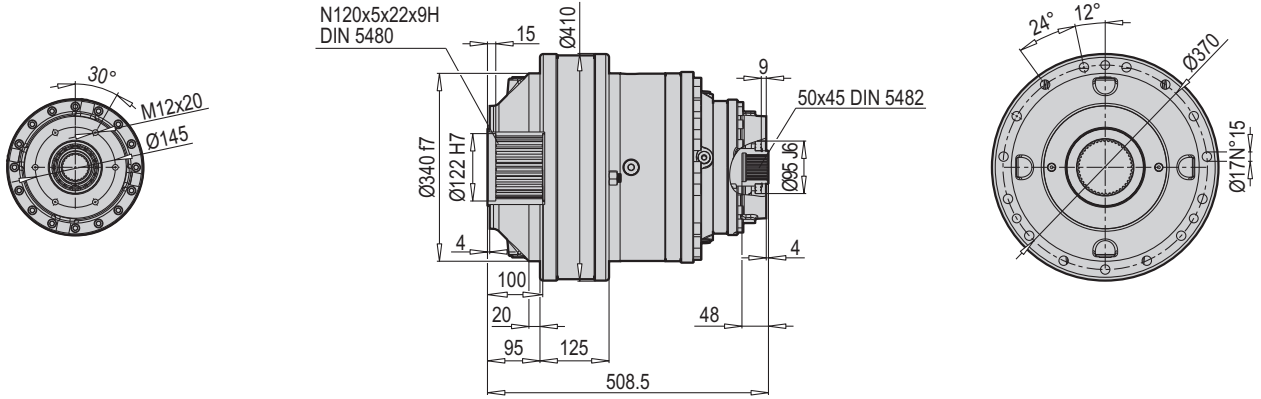

Tahvil Ratio i	Giriş Mili Input Shaft	Çıkış Mili Output Shaft	M ₂ max [Nm]
53.7	1"3/8 Z6	N120x5x22x9H DIN 5480	76500

* İsteğe bağlı olarak farklı tahvil değerleri yapılabilir.
Different ratio valves could be done upon request.

PYK PL 35003 F + 52

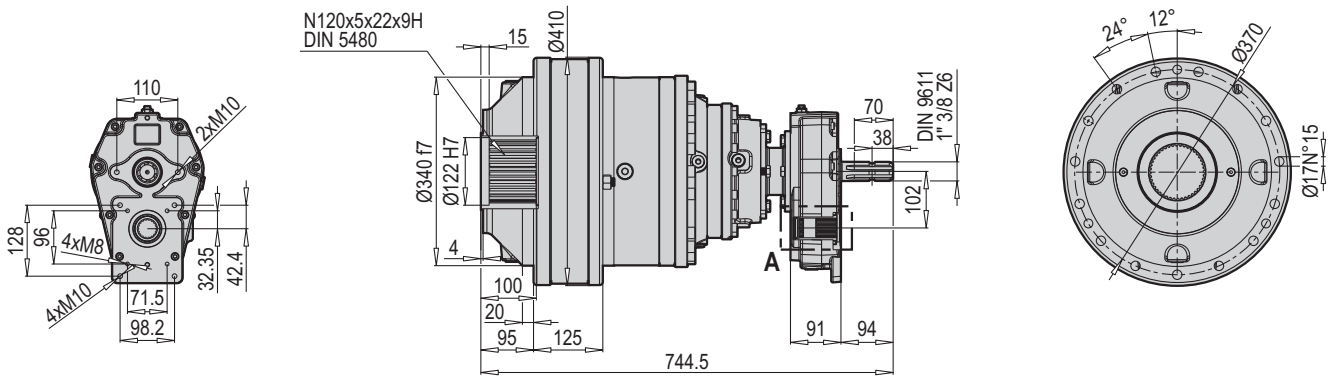

A DETAYI

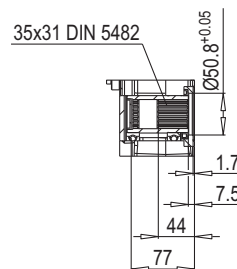

Tahvil Ratio i	Giriş Mili Input Shaft	Çıkış Mili Output Shaft	M ₂ max [Nm]
53.7	1"3/8 Z6	N120x5x22x9H DIN 5480	76500

* İsteğe bağlı olarak farklı tahvil değerleri yapılabilir.
Different ratio valves could be done upon request.

PYK PL 35003 F + SG

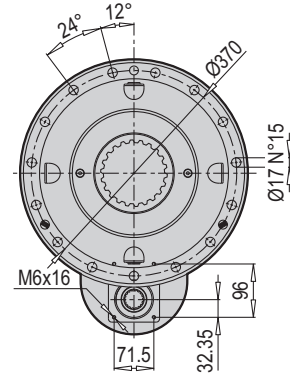
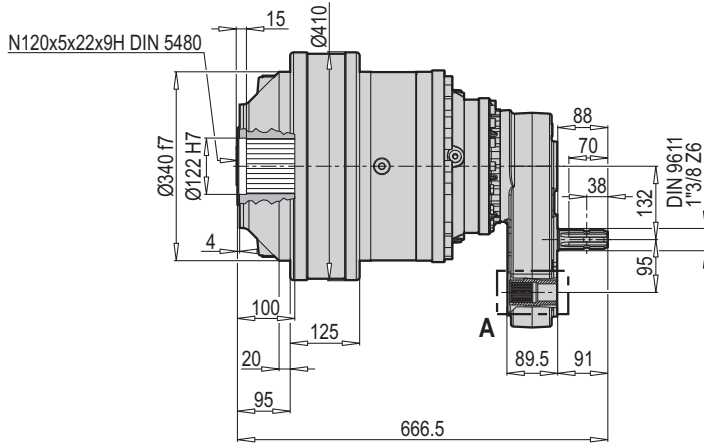

A DETAYI

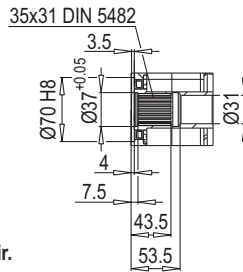

* İsteğe bağlı olarak farklı tahvil değerleri yapılabilir.
Different ratio valves could be done upon request.

Tahvil Ratio i	Giriş Mili Input Shaft	Çıkış Mili Output Shaft	M_2 max [Nm]
53.7	1"3/8 Z6	N120x5x22x9H DIN 5480	76500

PYK PL 35003 F + DB

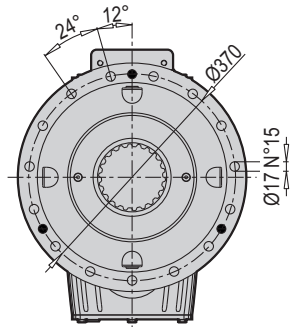
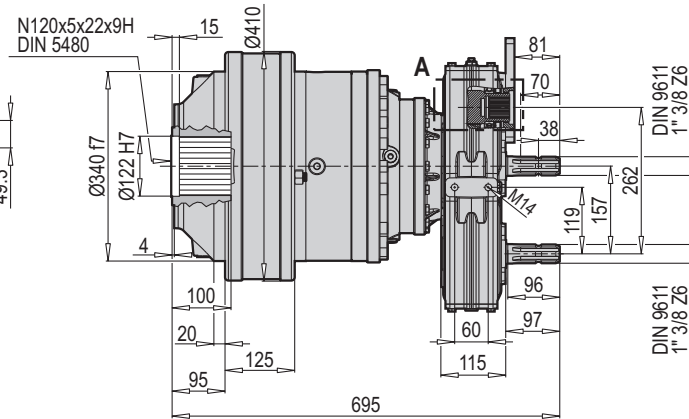
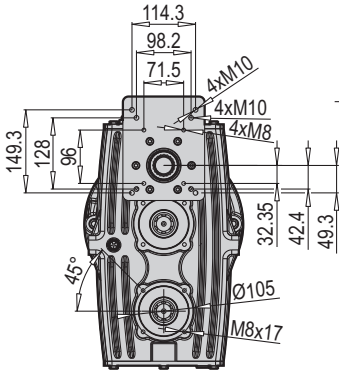

A DETAYI

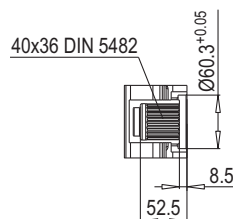

* İsteğe bağlı olarak farklı tahvil değerleri yapılabilir.
Different ratio valves could be done upon request.

Tahvil Ratio i	Giriş Mili Input Shaft	Çıkış Mili Output Shaft	M_2 max [Nm]
53.7	1"3/8 Z6	N120x5x22x9H DIN 5480	76500

PYK 130

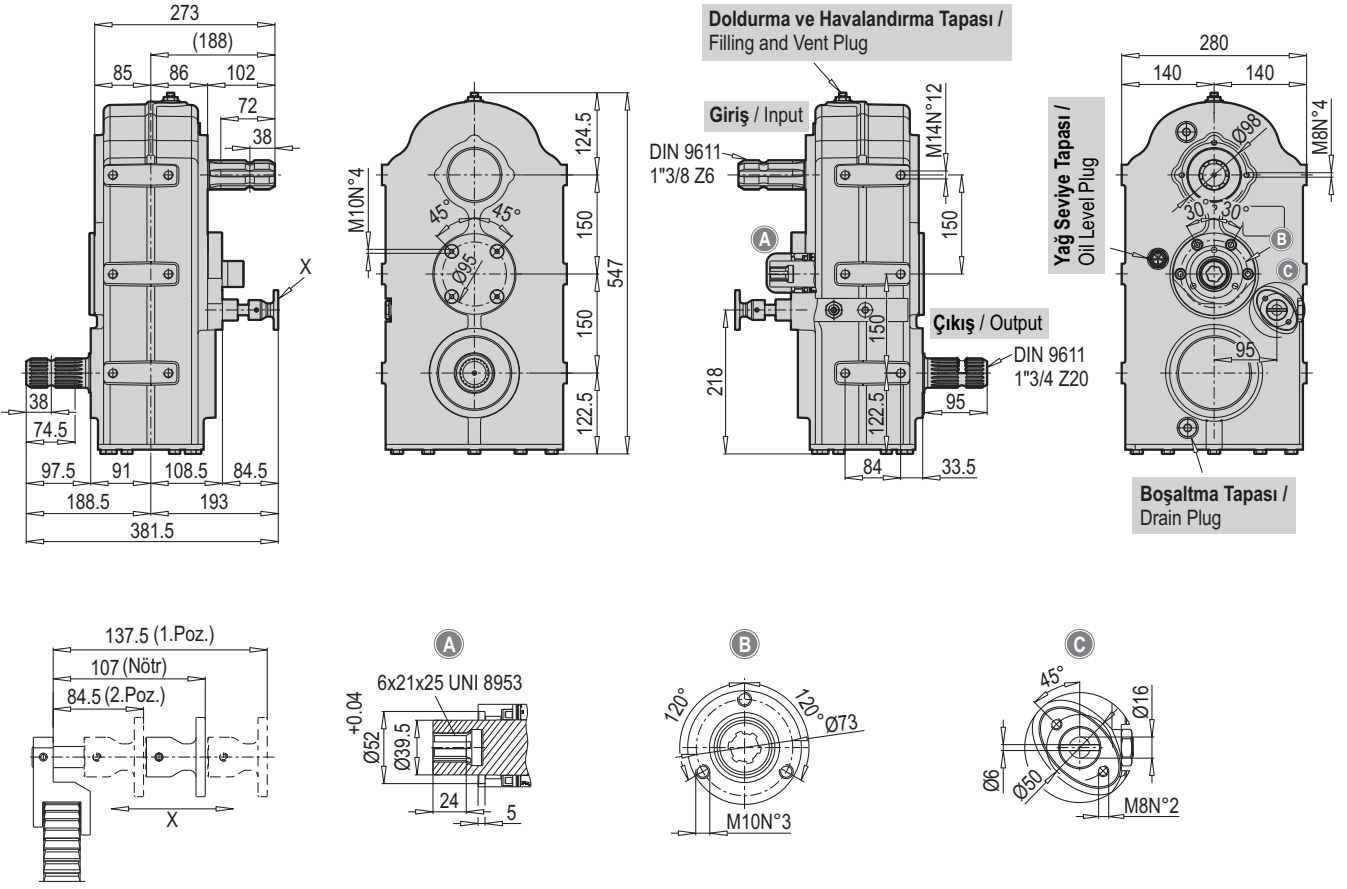

Tahvil Ratio i	Giriş Devri Input Speed [rpm]	Güç / Power		Moment / Torque [Nm]	
		[HP]	[kW]	Giriş Input	Çıkış Output
1.00:1	540	80	60	1.040	1.040
1.40:1		80	60	1.040	1.456
1.00:1		80	60	1.040	1.440
1.92:1		80	60	1.040	2.000

* Farklı giriş ve çıkış milleri mevcuttur. (Örn: 1"3/4 Z20) / Different input and output shafts available. (Exp: 1"3/4 Z20)

* İsteğe bağlı olarak farklı tahvil değerleri yapılabilir. / Different ratio values could be done upon request.

* Daha fazla bilgi için lütfen PGR satış departmanı ile irtibata geçiniz. / For more information please contact the PGR Sales Dept.

PYK 150

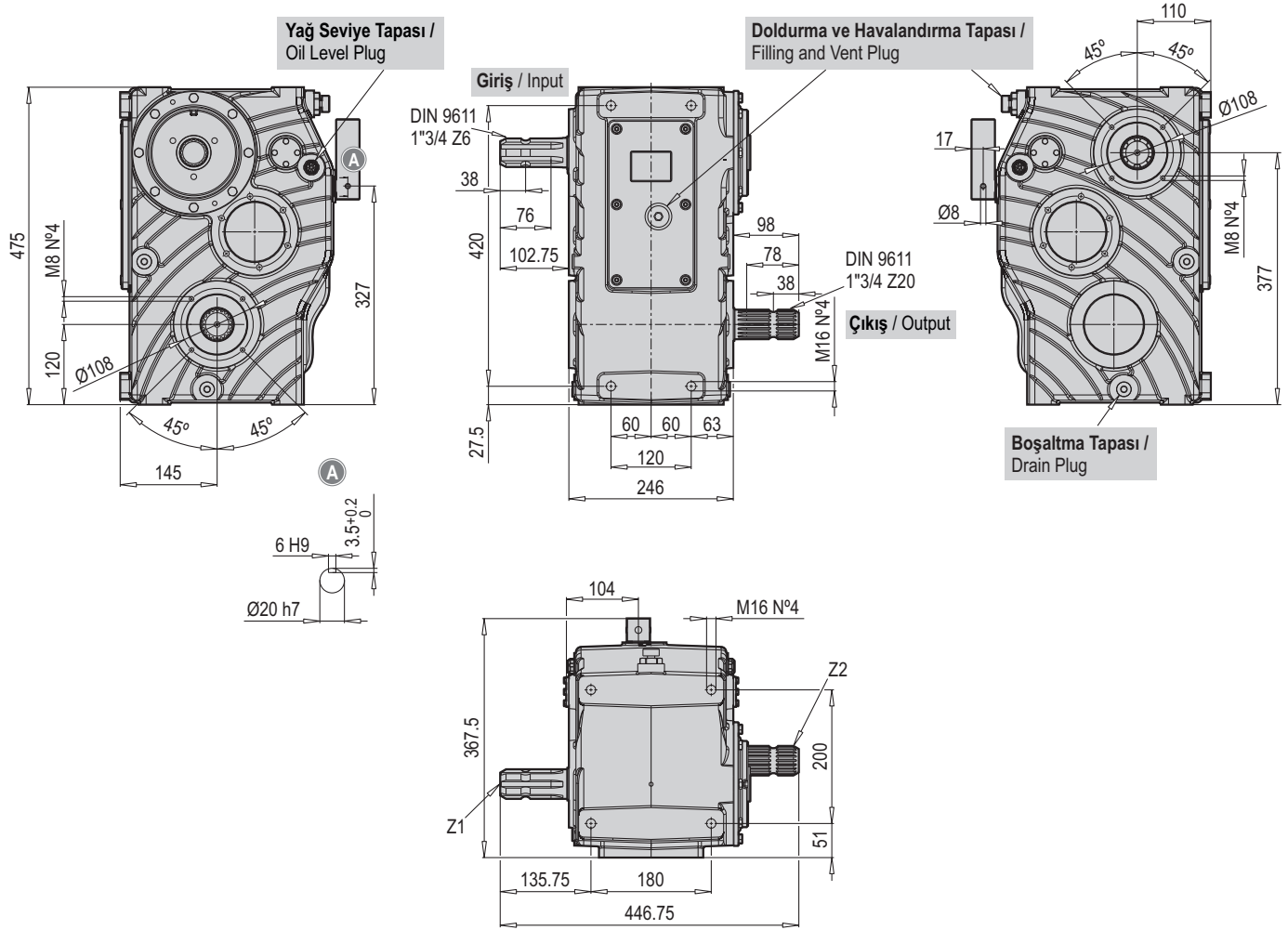

Tahvil Ratio i	Giriş Devri Input Speed [rpm]	Güç / Power		Moment / Torque [Nm]	
		[HP]	[kW]	Giriş Input	Çıkış Output
1.00:1 1.30:1	540	110	83	1.430	1.430
		105	79	1.365	1.774
1.00:1 1.30:1	1000	220	165	1.540	1.540
		220	165	1.540	2.010
1.00:1 1.80:1	540	110	83	1.430	1.430
		90	68	1.170	2.106
1.00:1 1.80:1	1000	220	165	1.540	1.540
		200	150	1.400	2.520
1.00:1 1.50:1	540	110	83	1.430	1.430
		100	76	1.300	2.008
1.80:1 2.70:1	1000	170	128	1.190	1.150
		150	113	1.050	2.835
1.00:1 1.17:1	540	110	83	1.430	1.430
		110	83	1.430	1.673
1.80:1 2.30:1	540	110	83	1.430	2.580
		110	83	1.430	3.300
1.80:1 3.20:1	1000	170	128	1.190	2.150
		150	113	1.050	3.360

* Farklı giriş ve çıkış milleri mevcuttur. (Örn: 1"3/4 Z20)
Different input and output shafts available. (Exp: 1"3/4 Z20)

* İsteğe bağlı olarak farklı tahvil değerleri yapılabilir.
Different ratio values could be done upon request.

* Daha fazla bilgi için lütfen PGR satış departmanı ile irtibata geçiniz.
For more information please contact the PGR Sales Dept.

PYK 180

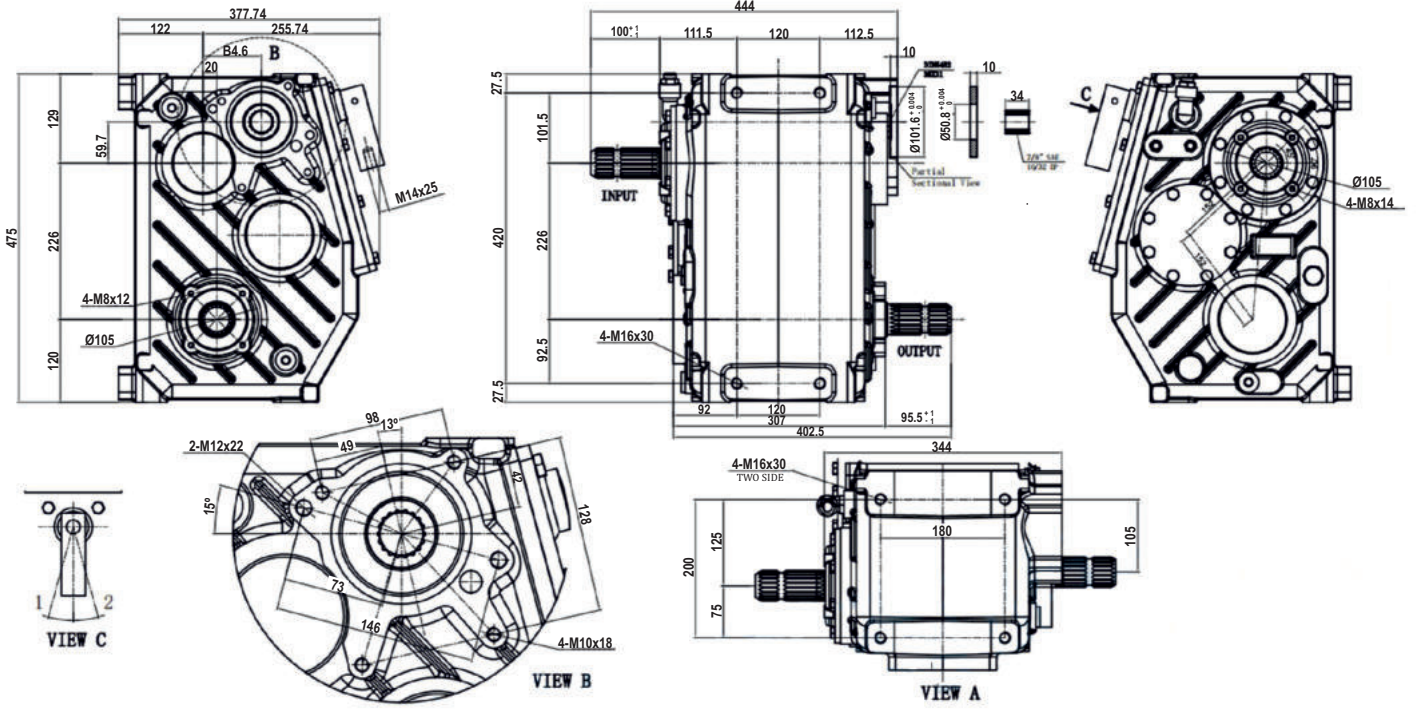

S.No.	Tahvil / Ratio i	GİRİŞ / INPUT(X)				ÇIKIŞ / OUTPUT(Y)				Giriş Mili / Shafts
		R.P.M	Moment / Torque [Nm]	[kW]	[HP]	Dişli 2 / Gear 1		Dişli 2 / Gear 2		
						R.P.M	Moment / Torque [Nm]	R.P.M	Moment / Torque [Nm]	GİRİŞ / INPUT
Hız Katsayısı/ Speed Multiplier	1:1-1:1.3	540	2334.4	132	180	540	2334.4	702	1795.7	X
	1:1-1:1.5	540	2334.4	132	180	540	2334.4	810	1556.3	X
	1:1-1:1.5	1000	1719	180	245	1000	1719	1500	1146	X
	1:1-1:1.8	540	2334.4	132	180	540	2334.4	972	1296.9	X
	1:1-1:1.8	1000	1719	180	245	1000	1719	1800	955	X
	1:1.8-1:2.7	1000	1432.5	150	204	1800	795.3	2700	530	X

YAĞLAYICI / LUBRICATING OIL:

AĞIRLIK / WEIGHT:127KG

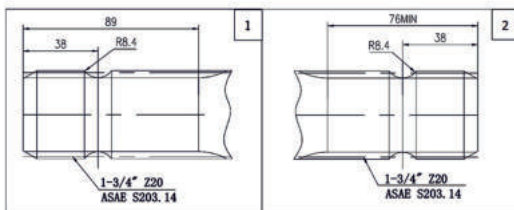
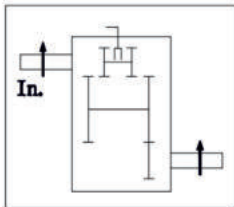

PYK 52

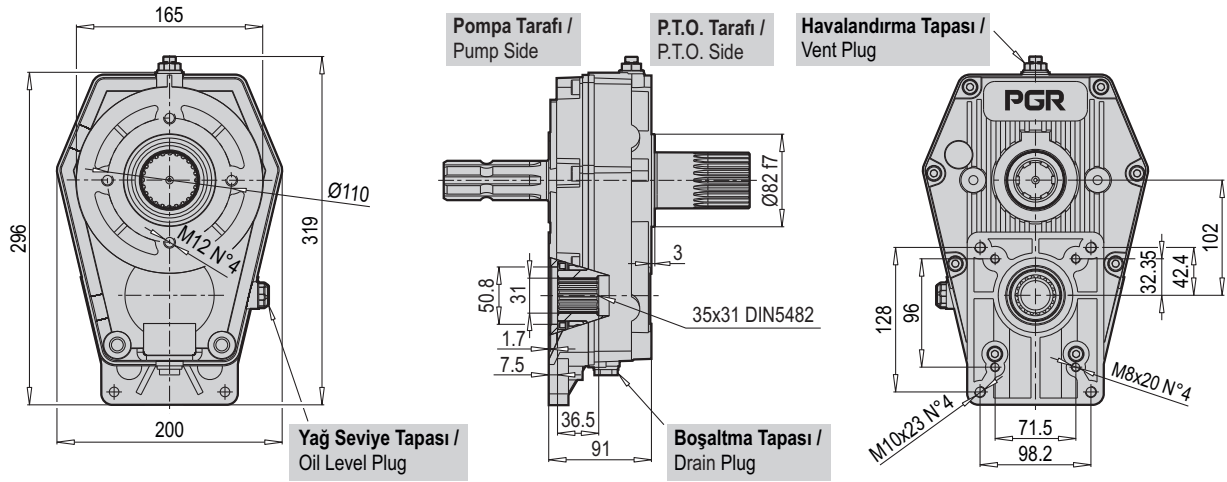

P.T.O.

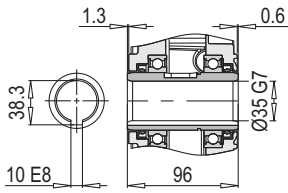

1 Ø 35

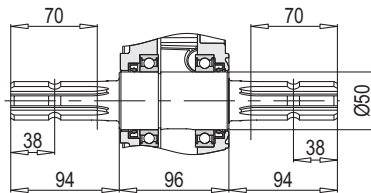

2 DIN 9611 1"3/8 Z6

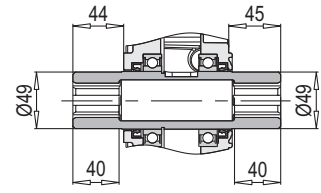

3 DIN 9611 1"3/8 Z6

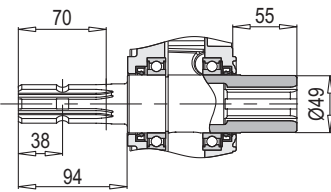

4 DIN 9611 1"3/8 Z6

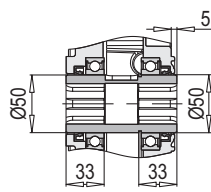

5 DIN 9611 1"3/8 Z6

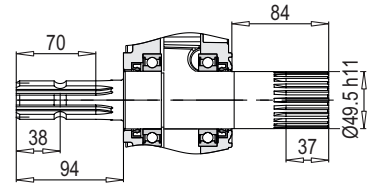

6 DIN 9611 1"3/8 Z6
DIN 5482 50x45

TR OTOMATİK TAHRİKLİ PYK YATAY YEM KARMA
 REDÜKTÖRLERİ

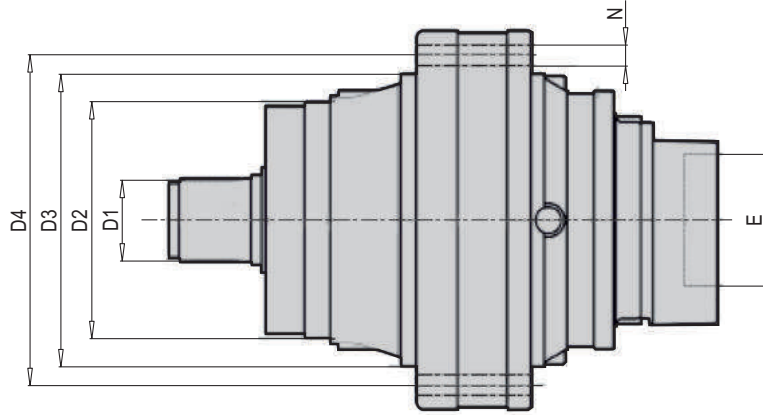
EN PKY HORIZONTAL FEED MIXING GEARBOXES
 WITH AUTOMATIC DRIVE

Gövde Boyutu Gear Unit Size	Tahvil / Ratio (*) i	D1	D2	D3	D4	N	E (**)
PL 16002 YK	22.1-33.6	80x74 DIN5482	225 f7	278 f7	314	Ø15 x N°18	SAE B / SAE C
PL 25002 YK	20.0-36.3	100x94 DIN5482	245 f7	340 f7	370	Ø17 x N°15	SAE B / SAE C

(*) İsteğe bağlı olarak farklı tahvil değerleri yapılabilir. / Different ratio values could be done upon request.

(**) Daha fazla bilgi için lütfen PGR satış departmanı ile irtibata geçiniz. / For more information please contact the PGR Sales Dept.

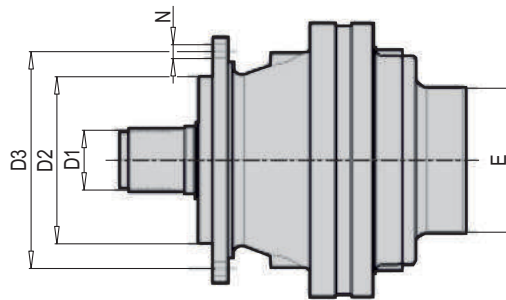

Gövde Boyutu Gear Unit Size	Tahvil / Ratio (*) i	D1	D2	D3	N	E (**)
PL 1601 YK	3.56 - 4.29 - 5.60	40x36 DIN5482	110 f7	165	Ø10.5 x N°8	SAE A / SAE B / SAE BB / OMTS
PL 2501 YK	4.13 - 5.17 - 6.00	58x53 DIN5482	150 f7	195	Ø13 x N°10	SAE A / SAE B / SAE BB / OMTS
PL 5001 YK	4.13 - 5.17 - 6.00	58x53 DIN5482	150 f7	195	Ø13 x N°10	SAE A / SAE B / SAE BB / OMTS

(*) İsteğe bağlı olarak farklı tahvil değerleri yapılabilir. / Different ratio values could be done upon request.

(**) Daha fazla bilgi için lütfen PGR satış departmanı ile irtibata geçiniz. / For more information please contact the PGR Sales Dept.



POLAT GROUP REDÜKTÖR SAN. ve TİC. A.Ş.

- ATA OSB Mah. Astim 1.Cad. No: 4 Efeler - Aydın / TÜRKİYE
- T: +90 256 231 19 12 • F: +90 256 231 19 17 • info@pgr.com.tr • www.pgr.com.tr

Dok. No: PG.KT.GT.014

Rev. / Yayın Tarihi: 12.2025_R1